

**WARRANTY  
REGISTRATION:**  
register online today for a  
chance to win a FREE Tripp Lite  
product—[www.tripplite.com/warranty](http://www.tripplite.com/warranty)



# Owner's Manual

**High Definition  
(HD) Compatible!**

## **isobar**<sup>®</sup> Digital Flat Panel Power Conditioning Center



<b>Safety</b>	<b>2</b>
<b>Features</b>	<b>2</b>
<b>Installation</b>	<b>3</b>
<b>Lifetime Limited Warranty</b>	<b>4</b>
<b>Ultimate Lifetime Insurance</b>	<b>4</b>
<b>Español</b>	<b>5</b>
<b>Français</b>	<b>9</b>



1111 W. 35th Street, Chicago, IL 60609 USA  
773.869.1234 (USA) • 773.869.1212 (International)  
[www.tripplite.com](http://www.tripplite.com)



## IMPORTANT SAFETY INSTRUCTIONS. SAVE THESE INSTRUCTIONS.

This manual contains instructions and warnings that should be followed during the installation and operation of all Tripp Lite Power Centers. Failure to heed these warnings will void your warranty.

- The Power Center features an internal protection that will disconnect the surge-protective component at the end of its useful life but will maintain power to the load—now unprotected.
- Do not connect the Power Center to an ungrounded outlet. Do not use with 2-wire extension cords or adapters. Do not plug extension cords into the Power Center.
- The Power Center is designed for indoor use only. Install the Power Center away from heat-emitting appliances such as radiators or heat registers. Do not install where excessive moisture is present.
- Never install electrical wiring during a lightning storm.
- Do not drill into any part of the housing or open the housing for any reason. There are no user-serviceable parts inside.
- Use of this equipment in life support applications where failure of this equipment can reasonably be expected to cause the failure of the life support equipment or to significantly affect its safety or effectiveness is not recommended. Do not use this equipment in the presence of a flammable anesthetic mixture with air, oxygen or nitrous oxide.

## Features

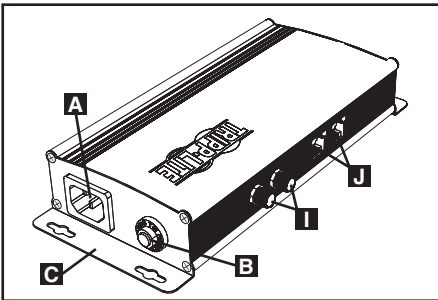

*Circuit Breaker, Cord and Back Panels*

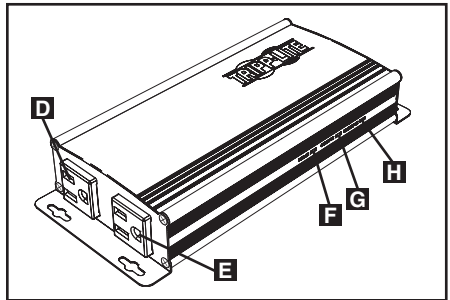

*Outlet Panel*

### Circuit Breaker & Cord Panel

- A Detachable Power Cord with Right-Angle Plug:** connects the Power Center to a standard 3-wire grounded 120V AC 60Hz wall outlet. Detachable cord simplifies installation; right-angle plug permits equipment and furniture to be placed flush against a wall.
- B Circuit Breaker:** protects against dangerous system overload. If the total load on the Power Center's outlets exceeds 12 amps, the circuit breaker will trip and power will be turned off at the outlets. Reduce the load by unplugging some devices. Depress the circuit breaker to restore power.
- C Mounting Flange:** allows for secure mounting (with user-supplied screws) on any suitable surface, including on a wall behind a flat panel TV screen. The user must determine the fitness of the mounting surface and the user-supplied screws prior to installation.

### Outlet Panel

- D "HDTV" Outlet:** protects any flat panel TV (plasma, LCD or HDTV) against surge damage and line noise distortion on the AC line. Turn power on and off at this outlet with the Power Switch.
- E "ACCESSORY" Outlet:** protects any accessory (receiver, player, etc.) against surge damage and line noise distortion on the AC line. Turn power on and off at this outlet with the Power Switch.
- F "LINE OK" LED:** indicates that nominal AC power is present with no wiring faults detected. When this LED is illuminated, AC power is safe for connected equipment.

## Features *(continued)*

- G “SURGE OK” LED:** indicates the surge-suppression components are intact and providing full protection. If this LED is not illuminated, make sure the Power Center is plugged in, the Power Switch is turned on and power is present. If the LED is still not illuminated, then some of the surge suppression components may not be functioning properly. Contact Tripp Lite Customer Support for assistance. You may still use the Power Center; however, connected equipment will be protected from surges at a lesser level than normal.
- H “GROUND OK” LED:** indicates the presence of a properly-grounded wall outlet. Note: A properly-grounded wall outlet is required for the Power Center to adequately protect connected equipment against surge damage. If this LED is not illuminated, make sure the Power Center is plugged in, the Power Switch is turned on and power is present. If the LED is still not illuminated, contact a qualified electrician to check for proper grounding.

## Back Panel

- I HD Bi-Directional Coaxial Input/Output Jacks:** protects Satellite, Cable, HDTV Master antennas against any damaging surges or spikes from coming through the coax lines.
- J RJ45 Network/Ethernet Protection Jacks:** covers all 8 pins for matrix switchers using cat5 and network inputs.

## Not Shown

**Audible Alarm:** immediately alerts you to damaged internal protection circuitry. If this occurs, contact Tripp Lite Customer Support.

## Installation

**STEP 1) Place or Mount Your Power Center:** Place the Power Center on a shelf or use mounting flanges to securely mount the Power Center (with user-supplied screws) on any suitable surface, including on a wall behind a flat panel TV screen. The user must determine the fitness of the mounting surface and the user-supplied screws prior to installation. Note: If possible, mount the Power Center so that its LEDs are visible.

**STEP 2) Connect Your Power Center to the AC Power Line:** Attach the power cord to the Power Center, then plug it in to a standard 3-wire grounded 120V AC 60Hz wall outlet, this will power-on the unit.

**STEP 3) Check Your Power Center's Diagnostic Indicator Lights:** Check the LEDs prior to connecting your equipment. They will indicate various operating conditions when the Power Center is plugged into a live 120V AC outlet.

**STEP 4) Connect Your Equipment to the Power Center's AC Outlets:** Plug your flat panel TV and accessory (if used) into the appropriately marked Power Center outlets. **DO NOT** plug in extension cords. **DO NOT OVERLOAD** the Power Center's outlets. The Power Center can accommodate a total equipment load of up to 12 amps. If the load on the Power Center exceeds 12 amps, the circuit breaker will trip and the outlets will stop providing power. If the circuit breaker trips, reduce the load by unplugging some devices. Depress the circuit breaker to restore power.

## Lifetime Limited Warranty

Seller warrants this product, if used in accordance with all applicable instructions, to be free from original defects in material and workmanship for its lifetime. If the product should prove defective in material or workmanship within that period, Seller will repair or replace the product, in its sole discretion. Service under this Warranty can only be obtained by your delivering or shipping the product (with all shipping or delivery charges prepaid) to: Tripp Lite, 1111 W. 35th St., Chicago, IL 60609. Seller will pay return shipping charges. The warranties of all TRIPP LITE power centers are null and void if they have been connected to the output of any UPS system. The warranties of all TRIPP LITE UPS Systems are null and void if a power center has been connected to its output receptacles.

**THIS WARRANTY DOES NOT APPLY TO NORMAL WEAR OR TO DAMAGE RESULTING FROM ACCIDENT, MISUSE, ABUSE OR NEGLIGENCE. SELLER MAKES NO EXPRESS WARRANTIES OTHER THAN THE WARRANTY EXPRESSLY SET FORTH HEREIN. EXCEPT TO THE EXTENT PROHIBITED BY APPLICABLE LAW, ALL IMPLIED WARRANTIES, INCLUDING ALL WARRANTIES OF MERCHANTABILITY OR FITNESS, ARE LIMITED IN DURATION TO THE WARRANTY PERIOD SET FORTH ABOVE; AND THIS WARRANTY EXPRESSLY EXCLUDES ALL INCIDENTAL AND CONSEQUENTIAL DAMAGES.** (Some states do not allow limitations on how long an implied warranty lasts, and some states do not allow the exclusion or limitation of incidental or consequential damages, so the above limitations or exclusions may not apply to you. This Warranty gives you specific legal rights, and you may have other rights which vary from jurisdiction to jurisdiction.) TRIPP LITE; 1111 35th St.; Chicago, IL 60609

**WARNING:** The individual user should take care to determine prior to use whether this device is suitable, adequate or safe for the use intended. Since individual applications are subject to great variation, the manufacturer makes no representation or warranty as to the suitability or fitness of these devices for any specific application.

### WARRANTY REGISTRATION

Visit [www.tripplite.com/warranty](http://www.tripplite.com/warranty) today to register the warranty for your new Tripp Lite product. You'll be automatically entered into a drawing for a chance to win a FREE Tripp Lite product!

\* No purchase necessary. Void where prohibited. Some restrictions apply. See website for details.

### Regulatory Compliance Identification Numbers

For the purpose of regulatory compliance certifications and identification, your Tripp Lite product has been assigned a unique series number. The series number can be found on the product nameplate label, along with all required approval markings and information. When requesting compliance information for this product, always refer to the series number. The series number should not be confused with the marking name or model number of the product.

Tripp Lite has a policy of continuous improvement. Product specifications are subject to change without notice.

Made in China.

## Ultimate Lifetime Insurance Policy

(This is a limited warranty valid in the U.S. and Canada only.)

Tripp Lite warrants, for the lifetime of the product, (at Tripp Lite's option) to repair or replace (on a pro rata basis) directly connected equipment that is damaged due to power transients while properly connected to Tripp Lite products offering the Ultimate Lifetime Insurance Policy. Power transients include spikes and surges on the AC power, data or telephone lines that the Tripp Lite products have been designed to protect against (as recognized by industry standards). The following four paragraphs are conditions that must be complied with before the warranty becomes valid; failure to comply with these requirements will void the warranty.

**AC Power Line Transients:** To claim damages, the Tripp Lite product must be plugged into a properly wired and grounded outlet. No extension cords or other electrical connections may be used. The installation must comply with all applicable electrical and safety codes set forth by the National Electrical Code (NEC). Except as provided above, this warranty does not cover any damage to properly connected electronic equipment resulting from a cause other than an "AC power transient". If user meets all of the above requirements, Tripp Lite will repair or replace (at Tripp Lite's option) equipment up to the specified value (See Ultimate Lifetime Insurance Policy Limits). No coverage is allowed for damage entering from telephone or data lines, unless they are separately protected, as described below.

**Telephone and Data Line Transients:** Tripp Lite will repair or replace directly connected equipment that is damaged by transients on telephone and/or data lines only when all such paths are protected by a Tripp Lite protection product(s) and the AC power (utility) line is simultaneously protected by a Tripp Lite power protection device (UPS, surge suppressor or line conditioner) with Ultimate Lifetime Insurance coverage. Additional telephone and/or data line connected devices downstream must have their own telephone and/or data line protectors.

Reimbursement dollar limits will be equal to that of the Tripp Lite power protection protector. Coverage is excluded where a suitable environment for the protection device is not provided, including, but not limited to, lack of a proper safety ground. Telephone service equipment must also include a properly installed and operating "primary protection" device at the telephone service entrance (such devices are normally added during telephone line installation).

All above warranties are null and void if the Tripp Lite product has been improperly installed, tampered with or altered in any way, or if the connected equipment was not used under normal operating conditions or in accordance with any labels or instructions. All claims under this warranty must be submitted in writing to Tripp Lite within 30 days of the occurrence or the claim will not be considered. This warranty does not include damage resulting from accident or misuse, and applies to the domestic (USA & Canada) use of these products only. Tripp Lite reserves the right to determine whether the damage to the connected equipment is due to malfunction of the Tripp Lite product by requesting the equipment in question be sent to Tripp Lite for examination. This policy is above and beyond, only to the extent needed, of that provided by any coverage of connected equipment provided by other sources, including, but not limited to, any manufacturer's warranty and/or any extended warranties.

**EXCEPT AS PROVIDED ABOVE, TRIPP LITE MAKES NO WARRANTIES, EXPRESS OR IMPLIED, INCLUDING WARRANTIES OF MERCHANTABILITY AND FITNESS FOR A PARTICULAR PURPOSE.** Some states do not permit limitation or exclusion of implied warranties; therefore, the aforesaid limitation(s) or exclusion(s) may not apply to purchaser. **EXCEPT AS PROVIDED ABOVE, IN NO EVENT WILL TRIPP LITE BE LIABLE FOR DIRECT, INDIRECT, SPECIAL, INCIDENTAL OR CONSEQUENTIAL DAMAGES ARISING OUT OF THE USE OF THIS PRODUCT, EVEN IF ADVISED OF THE POSSIBILITY OF SUCH DAMAGE.** Specifically, Tripp Lite is not liable for any costs, such as lost profits or revenue, loss of equipment, loss of use of equipment, loss of software, loss of data, costs of substitutes, claims by third parties or otherwise. Coverage also does not apply to connected medical and industrial equipment.

To receive service under this warranty, you must be the original purchaser/user of the product in question. You must obtain a Returned Material Authorization (RMA) number from Tripp Lite. Products must be returned to Tripp Lite with transportation charges prepaid and must be accompanied by a brief description of the problem encountered and proof of date and place of purchase.



1111 W. 35th Street, Chicago, IL 60609 USA  
773.869.1234 (USA) • 773.869.1212 (International)  
[www.tripplite.com](http://www.tripplite.com)