

**NEW 900 SERIES  
IN-WALL MIXER POWER AMPLIFIERS**

**W-906A  
W-912A**

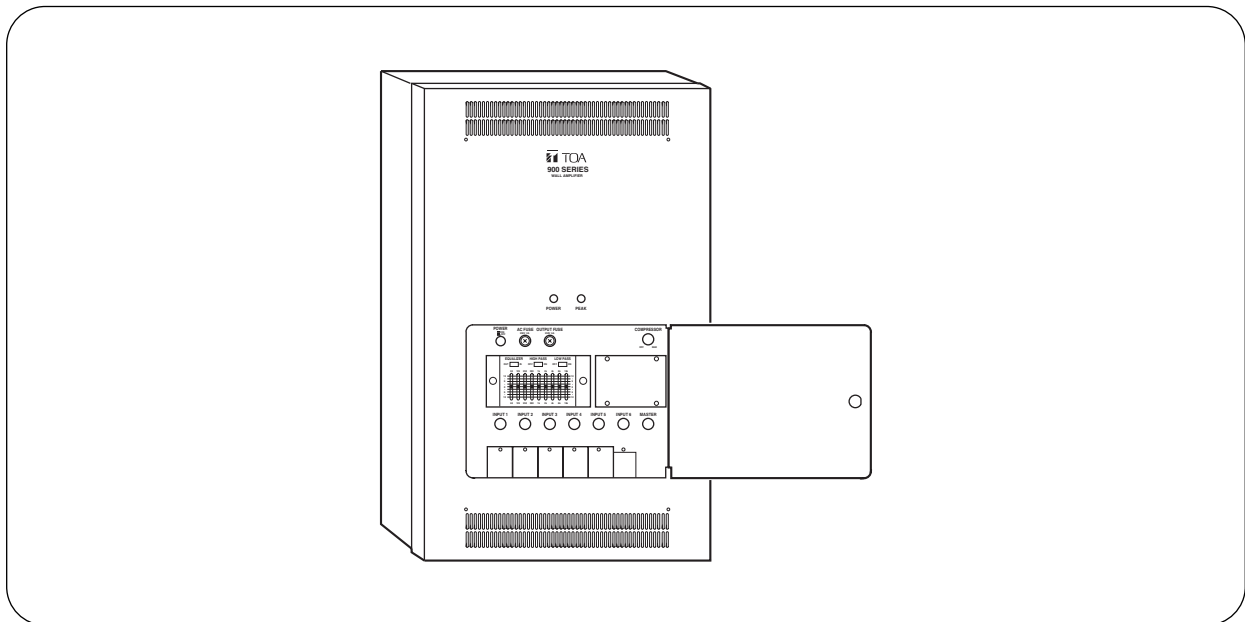

**TABLE OF CONTENTS**

<b>1. IMPORTANT SAFETY INSTRUCTIONS</b> .....	2	<b>8. SERVICING</b> .....	12
<b>2. SAFETY PRECAUTIONS</b> .....	3	<b>9. OPERATION</b> .....	13
<b>3. GENERAL DESCRIPTION</b> .....	5	<b>10. VOLUME CONTROL COVER ATTACHMENT</b> ..	14
<b>4. FEATURES</b> .....	5	<b>11. OUTPUT EQ CHARACTERISTIC</b> .....	14
<b>5. NOMENCLATURE AND FUNCTIONS</b>		<b>12. SPECIFICATIONS</b> .....	15
Front .....	6	Accessories .....	16
Front (viewed with the front cover removed) ...	7	Optional products .....	16
<b>6. INSTALLATION PRECAUTIONS</b> .....	8	<b>13. BLOCK DIAGRAM</b> .....	16
<b>7. INSTALLATION AND CONNECTION</b> .....	9		

**CAUTION**

These servicing instructions are for use by qualified service personnel only. To reduce the risk of electric shock, do not perform any servicing other than that contained in the operating instructions unless you are qualified to do so.

# 1. IMPORTANT SAFETY INSTRUCTIONS

- Read these instructions.
- Keep these instructions.
- Heed all warnings.
- Follow all instructions.
- Do not use this apparatus near water.
- Clean only with dry cloth.
- Do not block any ventilation openings. Install in accordance with the manufacturer's instructions.
- Do not install near any heat sources such as radiators, heat registers, stoves, or other apparatus (including amplifiers) that produce heat.
- Do not defeat the safety purpose of the polarized or grounding-type plug. A polarized plug has two blades with one wider than the other. A grounding type plug has two blades and a third grounding prong. The wide blade or the third prong are provided for your safety. If the provided plug does not fit into your outlet, consult an electrician for replacement of the obsolete outlet.
- Protect the power cord from being walked on or pinched particularly at plugs, convenience receptacles, and the point where they exit from the apparatus.
- Only use attachments/accessories specified by the manufacturer.
- Use only with the cart, stand, tripod, bracket, or table specified by the manufacturer, or sold with the apparatus. When a cart is used, use caution when moving the cart/apparatus combination to avoid injury from tip-over.



- Unplug this apparatus during lightning storms or when unused for long periods of time.
- Refer all servicing to qualified service personnel. Servicing is required when the apparatus has been damaged in any way, such as power-supply cord or plug is damaged, liquid has been spilled or objects have fallen into the apparatus, the apparatus has been exposed to rain or moisture, does not operate normally, or has been dropped.

## 2. SAFETY PRECAUTIONS

- Before installation or use, be sure to carefully read all the instructions in this section for correct and safe operation.
- Be sure to follow all the precautionary instructions in this section, which contain important warnings and/or cautions regarding safety.
- After reading, keep this manual handy for future reference.

### Safety Symbol and Message Conventions

Safety symbols and messages described below are used in this manual to prevent bodily injury and property damage which could result from mishandling. Before operating your product, read this manual first and understand the safety symbols and messages so you are thoroughly aware of the potential safety hazards.



The exclamation point within an equilateral triangle is intended to alert the user to the presence of important operation and maintenance (servicing) instruction in the literature accompanying the appliance.



### **WARNING**

Indicates a potentially hazardous situation which, if mishandled, could result in death or serious personal injury.

### When Installing the Unit

An all-pole mains switch with a contact separation of at least 3 mm in each pole shall be incorporated in the electrical installation of the building.

- Apparatus shall not be exposed to dripping or splashing and no objects filled with liquids, such as vases, shall be placed on the apparatus.
- Use the unit only with the voltage specified on the unit. Using a voltage higher than that which is specified may result in fire or electric shock.
- Do not cut, kink, otherwise damage nor modify the power supply cord. In addition, avoid using the power cord in close proximity to heaters, and never place heavy objects -- including the unit itself -- on the power cord, as doing so may result in fire or electric shock.
- Be sure to attach the front cover after connection completion. Because the voltage of up to 120 V is applied to internal terminals, never touch these terminals to avoid electric shock.
- External wiring connected to the terminals marked with ⚡ requires installation by an instructed person.
- The apparatus shall be connected to a mains socket outlet with a protective earthing connection.
- The socket-outlet shall be installed near the equipment and the plug shall be easily accessible.
- Install the unit only in a location that can structurally support the weight of the unit and the back box. Doing otherwise may result in the unit falling down and causing personal injury and/or property damage.
- Do not use other methods than specified to mount the unit and back box. Extreme force is applied to the unit and the unit could fall off, possibly resulting in personal injuries.
- Use nuts and bolts that are appropriate for the wall's structure and composition. Failure to do so may cause the unit to fall, resulting in material damage and possible personal injury.
- Tighten each nut and bolt securely. Ensure that the unit has no loose joints after installation to prevent accidents that could result in personal injury.
- Use the specified mounting back box in combination. Doing otherwise may cause the unit or component to fall off, resulting in personal injury.
- Do not mount the unit in locations exposed to constant vibration. The hinges can be damaged by excessive vibration, potentially causing the unit to fall, which could result in personal injury.
- Avoid installing the unit in locations close to the seashore or in indoor swimming facilities that are not well ventilated. In such locations, the unit may be vulnerable to corrosion, eventually allowing itself to fall resulting in personal injury.

### When the Unit is in Use

- Should the following irregularity be found during use, immediately switch off the power, disconnect the power supply plug from the AC outlet and contact your nearest TOA dealer. Make no further attempt to operate the unit in this condition as this may cause fire or electric shock.
  - If you detect smoke or a strange smell coming from the unit
  - If water or any metallic object gets into the unit
  - If the unit falls, or the unit case breaks
  - If the power supply cord is damaged (exposure of the core, disconnection, etc.)
  - If it is malfunctioning (no tone sounds.)
- To prevent a fire or electric shock, never open nor remove the unit front cover as there are high voltage components inside the unit. Refer all servicing to your nearest TOA dealer.
- Do not place cups, bowls, or other containers of liquid or metallic objects on top of the unit. If they accidentally spill into the unit, this may cause a fire or electric shock.
- Do not insert nor drop metallic objects or flammable materials in the ventilation slots of the unit's cover, as this may result in fire or electric shock.



### **CAUTION**

Indicates a potentially hazardous situation which, if mishandled, could result in moderate or minor personal injury, and/or property damage.

### When Installing the Unit

- Never plug in nor remove the power supply plug with wet hands, as doing so may cause electric shock.
- When unplugging the power supply cord, be sure to grasp the power supply plug; never pull on the cord itself. Operating the unit with a damaged power supply cord may cause a fire or electric shock.
- Do not block the ventilation slots in the unit's cover. Doing so may cause heat to build up inside the unit and result in fire.
- Avoid installing the unit in humid or dusty locations, in locations exposed to the direct sunlight, near the heaters, or in locations generating sooty smoke or steam as doing otherwise may result in fire or electric shock.
- To avoid electric shocks, be sure to unplug the unit's power supply cord when connecting speakers.
- When unpacking or moving the unit, be sure to handle it with two or more persons. Falling or dropping the unit may cause personal injury and/or property damage.

### When the Unit is in Use

- Do not place objects on the unit as this may cause it to fall or break which may result in personal injury and/or property damage. In addition, the object itself may fall off and cause injury and/or damage.
- Make sure that the volume control is set to minimum position before power is switched on. Loud noise produced at high volume when power is switched on can impair hearing.
- Do not operate the unit for an extended period of time with the sound distorting. This is an indication of a malfunction, which in turn can cause heat to generate and result in a fire.
- If dust accumulates on the power supply plug or in the wall AC outlet, a fire may result. Clean it periodically. In addition, insert the plug in the wall outlet securely.
- Switch off the power, and unplug the power supply plug from the AC outlet for safety purposes when cleaning or leaving the unit unused for 10 days or more. Doing otherwise may cause a fire or electric shock.
- Do not stand or sit on, nor hang down from the unit as this may cause it to fall down or drop, resulting in personal injury and/or property damage.



The lightning flash with arrowhead symbol, within an equilateral triangle, is intended to alert the user to the presence of uninsulated "dangerous voltage" within the product's enclosure that may be of sufficient magnitude to constitute a risk of electric shock to persons.



## ATTENTION

L'appareil ne doit pas être exposé aux éclaboussures ou écoulements et tous objets remplis de liquide, tels que vases, ne doivent pas être sur l'appareil.

### 3. GENERAL DESCRIPTION

The TOA W-906A and W-912A In-Wall Mixer Power Amplifiers control and mix up to six independent input signals plus two inputs with use of WE-2 Expanding kit. The W-906A delivers up to 60 W of output power and the W-912A 120 W. Optional accessory modules are available for use with the W-906A and W-912A to provide versatility for a wide range of operating applications. Edge connectors at the bottom of the front panel permit the selection of the TOA plug-in modules. (Please contact your local TOA dealer for details on TOA plug-in modules.)

The W-906A and W-912A have a built-in one-octave graphic equalizer with 9 bands to tailor sound system frequency response to room acoustics, reducing feed-back tendencies and improving intelligibility. A built-in compressor circuit is provided to protect the output level from distortion as a result of excessive input and keeps it constant. Compressor's threshold level can be adjusted.

The speaker output terminals are designed to match 25 or 70 V line, or 4 or 8  $\Omega$  speaker systems.

User's space (blank) is provided for loading the WE-2 Expanding kit (optional), enabling the number of inputs to be increased by two. Protection against tampering is assured by means of a key-locked hinged door. The W-906A and W-912A can be mounted in any four-inch wall with of the BX-9F Flush-mounting (in-wall) back box. On-wall mounting is also possible with the BX-9S Surface-mounting (on-wall) back box.

### 4. FEATURES

- 6-channel mixer power amplifier
- Expandable to 8-input
- Output power: 120 W for W-912A, 60 W for W-906A
- Wide frequency response: 30 Hz to 20 kHz  $\pm$ 1dB
- Low distortion and noise
- Excellent output regulation
- Built-in one-octave equalizer
- Built-in compressor
- Self-protection circuitry design
- Separate output terminals: 4 and 8  $\Omega$ , 25 and 70 V
- Extra space for customizing
- LED peak indicator
- Full range of plug-in modules
- Flush and surface mounting

## 5. NOMENCLATURE AND FUNCTIONS

[Front]

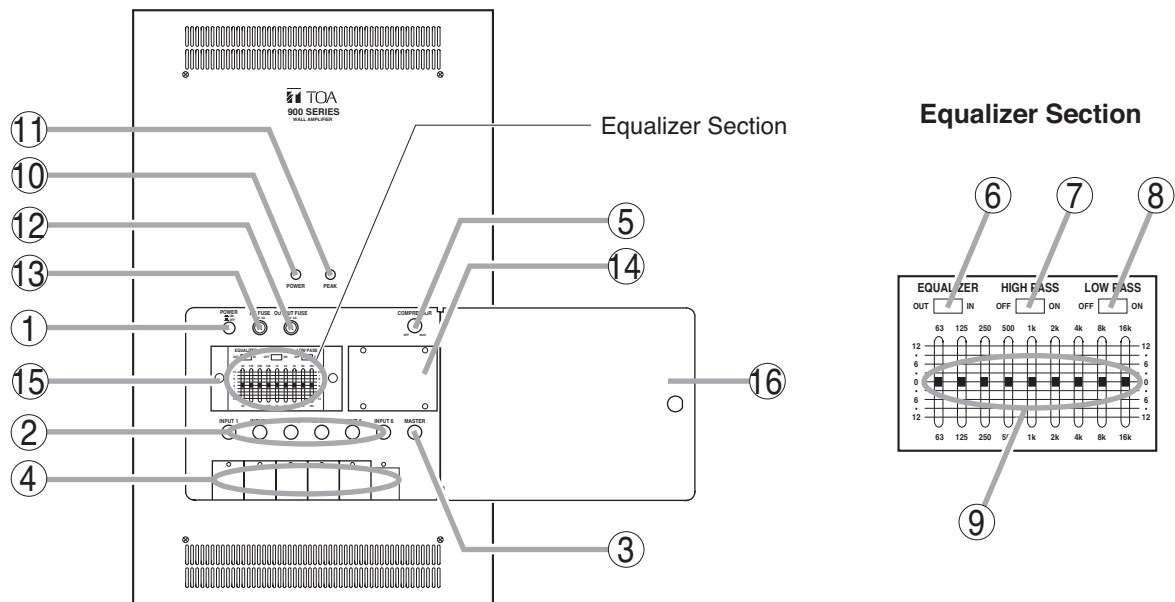

- 1. Power switch [POWER]**  
Power is switched on and off with each depression of this switch.
- 2. Input volume controls [INPUT 1 – 6]**  
Adjust gain of input 1 – 6 respectively.  
Adjust the input volume of each input channel.  
Write the input source name on the enclosed indication label, then attach it just below the corresponding control.
- 3. Master volume controls [MASTER]**  
Adjusts overall gain of all input channels.
- 4. Blank panels**  
Cover the Module input ports (21) when shipped from the factory.  
When mounting a module, remove the blank panel corresponding to the port.
- 5. Compressor control (limiter) [COMPRESSOR]**  
Setting the control switch to OFF position bypasses the compressor circuit. As the control is turned clockwise, the output level is limited stronger.
- 6. Equalizer switch [EQUALIZER]**  
Place this switch in the IN position to activate an equalizer.
- 7. High-pass filter switch [HIGH PASS]**  
Place this switch in the ON position to cut off unnecessary low frequencies.
- 8. Low-pass filter switch [LOW PASS]**  
Place this switch in the ON position to cut off unnecessary high frequencies.
- 9. Equalizer controls**  
9 band filters. 12 dB of boost and cut at each center frequency.
- 10. Power indicator**  
Lights when power is switched on.
- 11. Peak indicator**  
Lights if input signals approach clipping level. If steady lit, turn down the corresponding Input volume control until the indicator flashes only intermittently.
- 12. Output fuse [OUTPUT FUSE]**  
Protects against excessive current flow.  
W-906A: 250 V, 6 A  
W-912A: 250 V, 10 A
- 13. AC fuse [AC FUSE]**  
Protects against excessive current flow.  
W-906A: 250 V, 3 A  
W-912A: 250 V, 5 A
- 14. Blank panel (user's space)**  
The space of 103 (w) x 63 (h) x 95 (d) mm (4.06" x 2.48" x 3.74") is provided.  
An optional expanding kit (WE-2) may be loaded in this space.
- 15. Equalizer security cover**  
Protects against inadvertent changes of the equalizer controls set at proper level.
- 16. Key-locked door**  
Protects against tampering.

**[Front]** (viewed with the front cover removed)

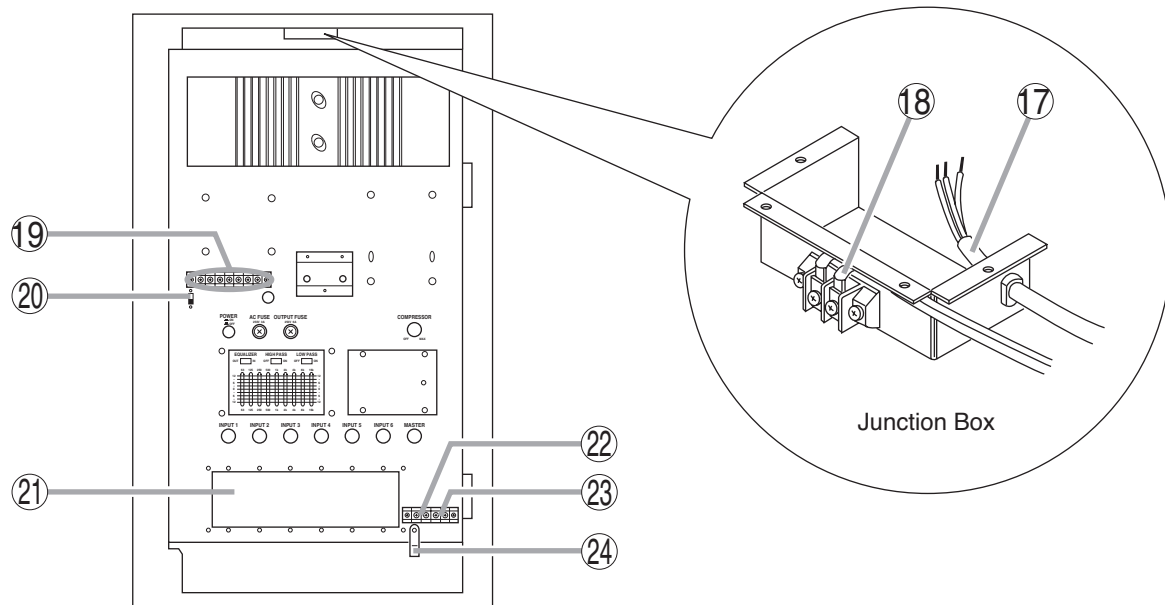

**17. AC power cable**

Connects to power source.

**18. Speaker output terminals**

Connect to speakers.

**19. Output terminals**

Select output impedance with this terminal.

**20. Low-cut switch**

Cuts off unnecessary low frequency.

**21. Module input ports**

Accept 900 series plug-in modules. For the selection of the most appropriate modules, refer to Plug-in Module Instruction manual.

**22. Bridging input/output terminals**

-20 dB (100 mV), 3.3 kΩ

This terminal is used as a mixing bus.

Connecting this terminal to the similar terminal of another amplifier achieves mixing. The signals appearing at the terminal are independent of all controls except input volume controls so that this terminal can also be used as recording output.

The input impedances of the equipment to be connected here should be more than 10 kΩ.

**23. Mute terminals**

Activate mute control only to the modules having mute function.

Short-circuiting the Mute terminals mutes the modules set for "mute receive" function.

**24. Cord clamp**

Clamps off lead wires from module inputs, mute terminals and bridging input/output terminals.

## 6. INSTALLATION PRECAUTIONS

- The unit is designed for wall mounting. To secure ventilation, never install it in a horizontal or face-up orientation.

Correct orientation

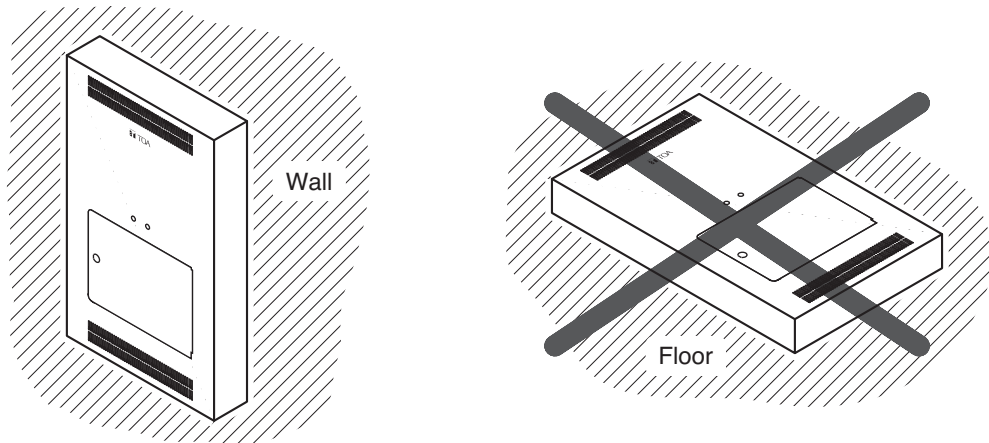

- To provide enough space for operation and ventilation, never place objects in areas shown in the figures below.

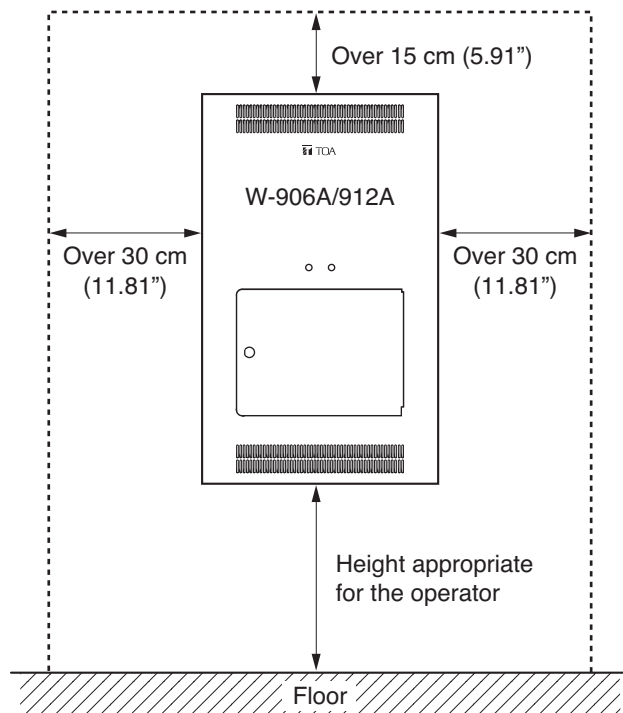
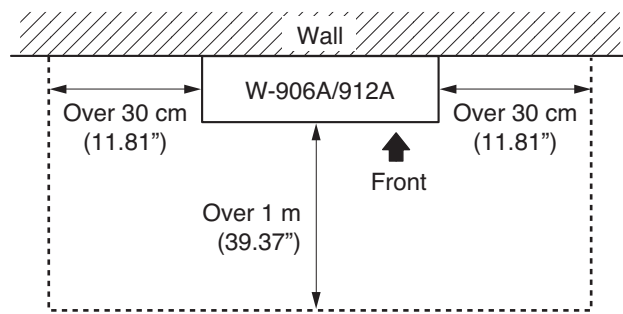



## 7. INSTALLATION AND CONNECTION

Installing this amplifier requires the optional back box, which is Model BX-9F for flush mounting in any 4 inch wall and Model BX-9S for surface mounting.  
Fix the back box first before installing the amplifier.

### 7.1. Installation Procedures

**Step 1.** Attach the supplied hinges to the back box using the 6 supplied M3 x 6 machine screws.

**Step 2.** Fix the amplifier to the back box by inserting the amplifier bolts into the hinges as illustrated.

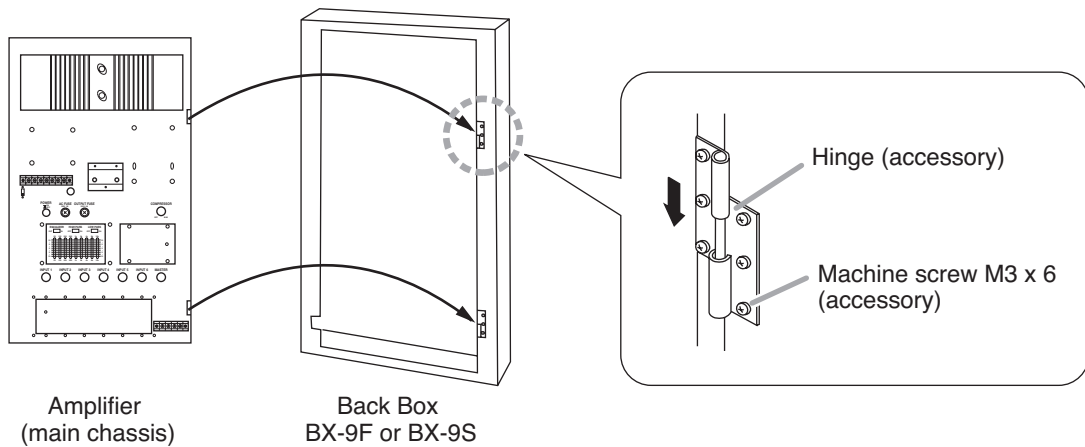

**Step 3. Connect the power cable.**

Be sure to make proper cable connections according to color coding of the power cable.  
After connection completion, wrap insulation tape around cable joints and put them in a junction box.

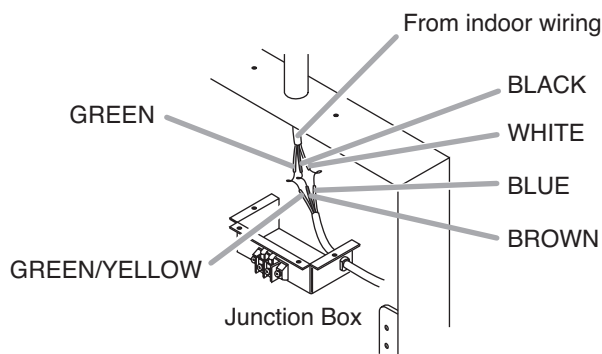

**Step 4. Attach the junction box to the back box using the supplied screws as shown below.**

The BX-9F differs from the BX-9S in the way to attach the junction box to the back box.

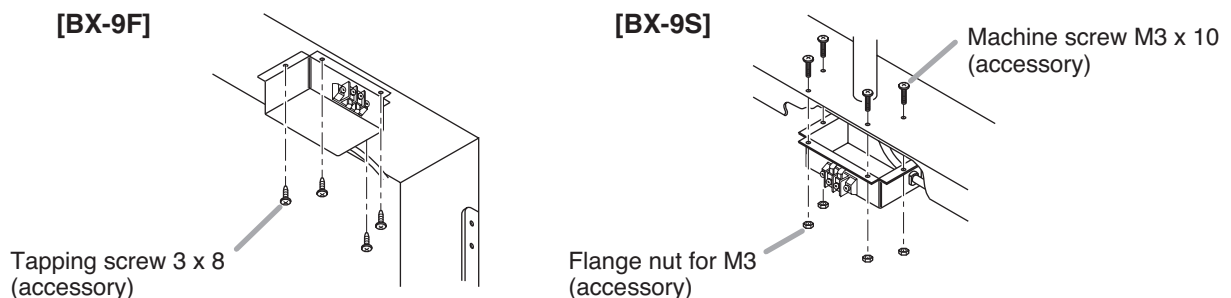

### Step 5. Connect the speaker cable.

Connect the speaker cable to the speaker output terminals on the junction box. Amplifier output impedance may be selected at the output terminals on the front panel.

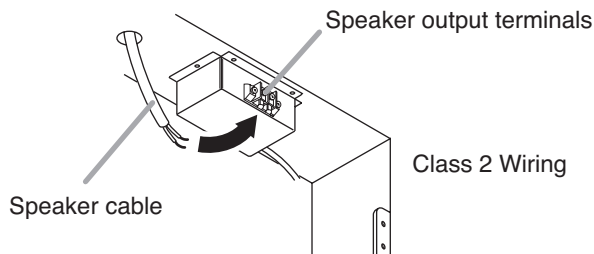

#### [Speaker cable treatment]

Strip 10 mm (0.39") of insulative jacket from the cable end, as shown in the figure at right.

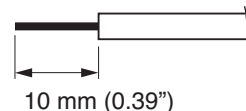



## WARNING

The terminals marked with the symbol ⚡ are hazardous live. The external wiring to these terminals requires installation by an instructed person.

### Step 6. Fix the amplifier.

Secure the amplifier to the back box using the 3 supplied M4 x 10 machine screws after connecting the power cable and the speaker cables. Note that the extra 2 out of 5 supplied screws are spare.

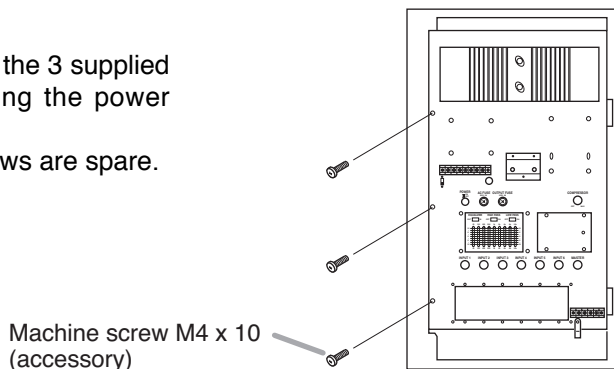

### Step 7. Select output impedance.

Select appropriate output impedance that matches the speaker to be used. Use Class 2 wiring.

The unit has 25 V and 70 V outputs for constant voltage speaker system and low impedance output for 4 Ω and 8 Ω speaker loads. In these speaker outputs, only the 4 Ω output is a direct output while other outputs are transformer outputs. Connect the speaker system to only one of the speaker outputs. Refer to the following connection diagrams described for each model.

**Note:** Impedances indicated in the diagrams mean total speaker load impedance.

#### [W-906A]

Change cable connection for required impedance according to the speaker used.

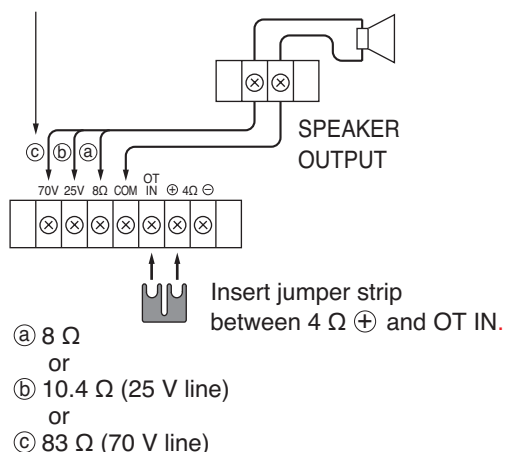

#### [W-912A]

Change cable connection for required impedance according to the speaker used.

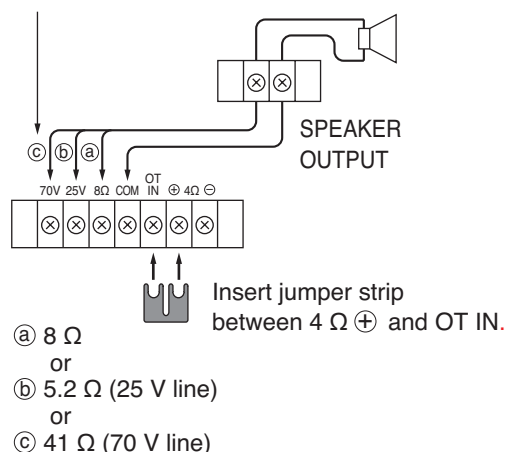

### Note

It is highly recommended that the low-cut switch be placed in the CUT position to cut off unnecessary low frequency. This is because the built-in transformer cannot produce low frequencies though the unit has flat response even in low-frequency range.

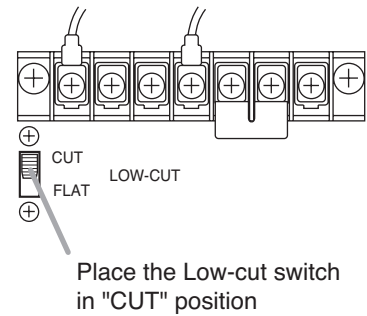

- When connecting speakers to the 4 Ω output (UNBALANCED DIRECT OUTPUT), connect as illustrated below.

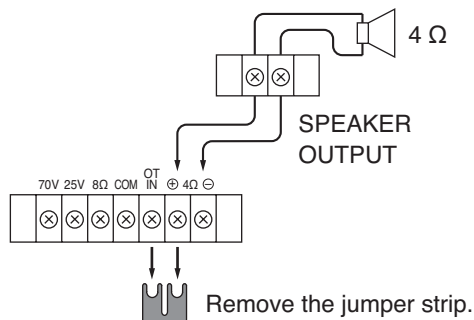

### Step 8. Install modules.

Six input ports for plug-in modules are provided. Select the desired modules depending on applications. Plug the modules fully into the input ports by sliding them along the upper and lower guide rails, then secure each with two screws.

Be sure to cover idle slots with the blank panels attached to the unit and secure each with two screws.

### Important

Be sure to switch off the unit's power when inserting or removing the modules. Failure to do so may cause modules to fail.

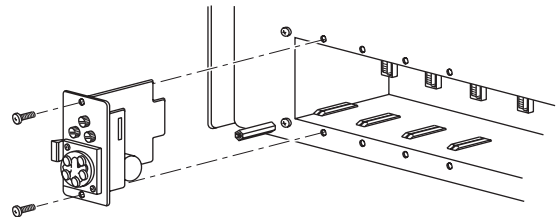

### Step 9. Attach the front cover.

To complete installation, be sure to attach the front cover onto the installed amplifier with the supplied 4 screws (screw thread by inch system).



## WARNING

Be sure to attach the front cover after connection completion. Because high voltage is generated at the speaker output terminals, never touch these terminals to avoid electric shock.

## 7.2. Input Expander

The optional expanding kit WE-2 is necessary to increase the number of input.

Up to two inputs may be added by loading the expanding kit in the user's space. For details, refer to the instruction manual of the kit.

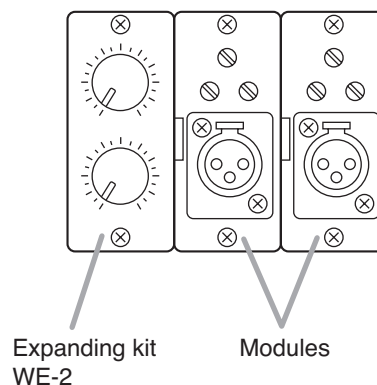

### Note

When the temperature of heat sink exceeds 105°C (221°F), the protection circuit disconnect the output. Operation automatically returns to normal when the temperature decreases. In such a case, confirm whether or not the unit is overloaded or operated on an excessive output.

## 8. SERVICING

### 8.1. Unpacking

Upon receipt of the amplifier shipment, please check for any damage incurred in transit. If damage is found, please notify your local TOA representative and the transportation company immediately.

State date, nature of damage, whether any damage was noticed on the shipping container, prior to unpacking. Please give waybill number of shipping order.

### 8.2. Failure

Should amplifier fail, contact your nearest TOA authorized contractor or service center.

## 9. OPERATION

Be sure to complete all connections before operation.

### 9.1. Basic Operation Procedure

**Step 1.** Press the power switch to turn on the power.

The power indicator lights. The amplifier comes into operation about 5 seconds after the power has been switched on.

**Step 2.** Adjust the individual input and master volume controls for the optimum level.

Turn the knob clockwise to increase the output level and counterclockwise to decrease it. Sound quality is downgraded when the Peak Indicator remains lit.

**Step 3.** Adjust the graphic equalizer.

The one-octave graphic equalizer allows more precise frequency adjustments response to room acoustics, reducing feedback opportunities and improving intelligibility.

Characteristic of this equalizer is on p.14. Adjust it to obtain the desired frequency response by actually hearing the sound or by using pink noise.

To make the adjustment, place the EQ switch in the IN position.

If a control knob is moved up, center frequency is boosted and if down, it is cut. Placing the EQ switch in the OUT position bypasses the equalizer circuit and makes frequency response flat.

### 9.2. Filter ON/OFF

When the HIGH PASS FILTER switch is in the ON position, low frequency is cut. In this event, low frequency below 180 Hz may be cut at a 12 dB/OCTAVE rate. When LOW PASS FILTER switch is in the ON position, high frequency of 7 kHz or higher may be cut at a 12 dB/OCTAVE rate.

To bypass the filter, place the filter switch in the OFF position.

### 9.3. Compressor ON/OFF

If the COMPRESSOR CONTROL switch is set to OFF, it bypasses the compressor circuit. Turn it clockwise to activate the compressor and to adjust the limiting level. Since turning it fully clockwise limits the output level to the maximum, be sure to turn it to the appropriate position so that the Peak indicator does not light.

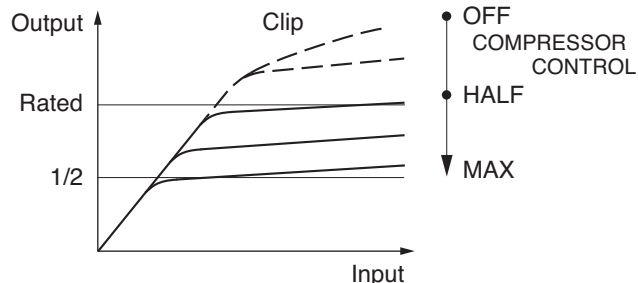

### 9.4. Adjusting release time

Compressor release time is factory-preset at 2 seconds. Adjust the release time with the Release time control as needed. Turn the control to the MAX position to increase the release time, and to the MIN position to decrease it.

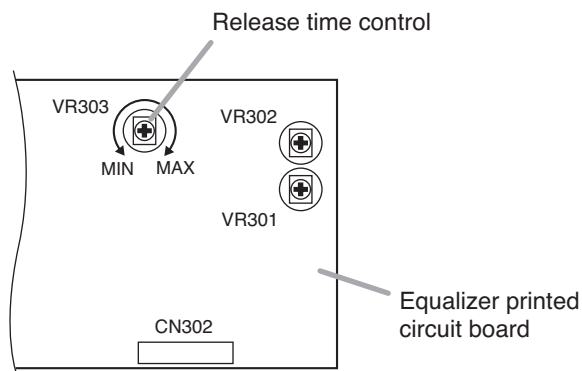

### 9.5. Replacing Fuse

Each amplifier has an output fuse to protect the amplifier from short-circuiting at the output or overloading. Check the fuse when speakers connected do not sound. If the fuse blew, replace with the same type fuse after confirming the following points.

- Speaker cables are not short-circuited or the load does not exceed the rating specified.
- Wiring is correctly done at the output terminal board.

## 10. VOLUME CONTROL COVER ATTACHMENT

To protect the input volume control from accidental operation, it is recommended to replace the control knob with the supplied volume control cover.

**Step 1.** After adjusting the input volume control, remove its knob.

**Step 2.** Attach the supplied volume control cover in place of the knob.

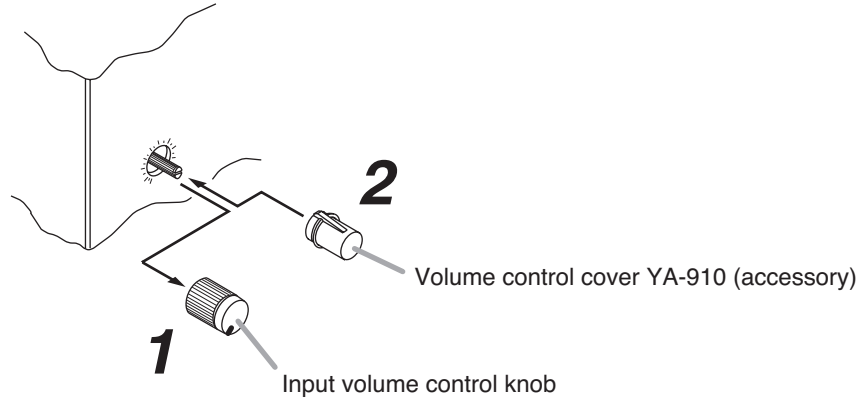

### Note

The unit comes with 3 volume control covers as standard accessories. Ask for the optional one model YA-910 as necessary.

## 11. OUTPUT EQ CHARACTERISTIC

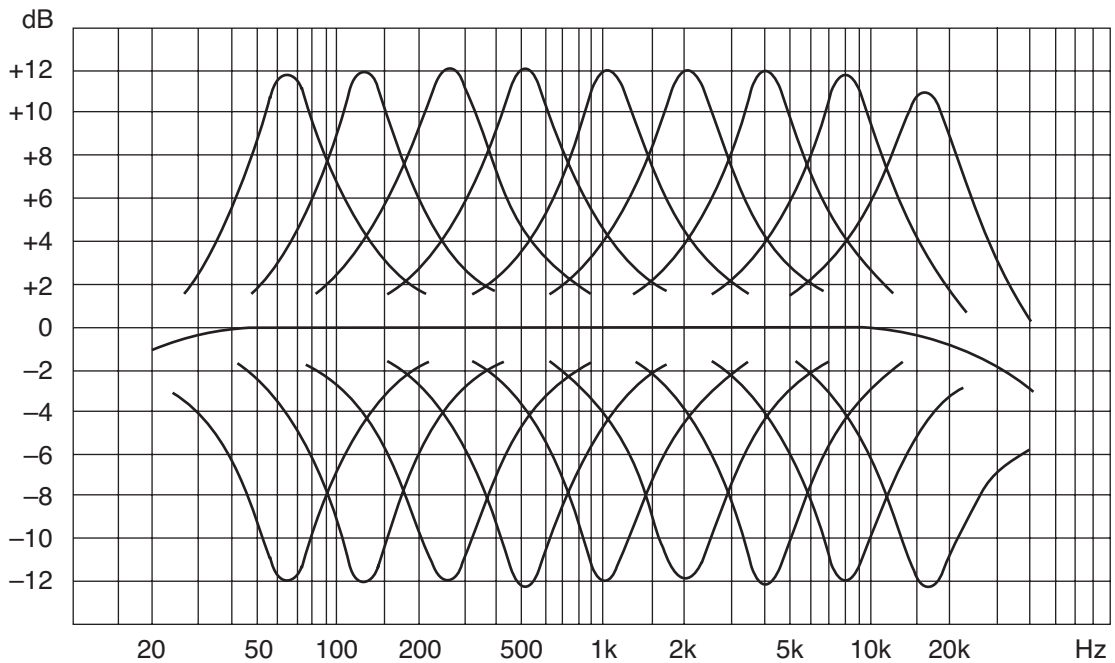

## 12. SPECIFICATIONS

Model No.	W-906A	W-912A
Type	Wall mounting 6-channel mixer power amplifier	
Output Power	60 W RMS	120 W RMS
Power Bandwidth	(D): 20 Hz – 20 kHz, 0.5% THD (T): 20 Hz – 20 kHz, 0.5% THD	
Frequency Response	(D): 30 Hz – 20 kHz, $\pm 1$ dB (T): 30 Hz – 15 kHz, $\pm 1$ dB (T): 30 Hz – 20 kHz, $\pm 1$ dB, – 3 dB	
Total Harmonic Distortion	0.02% at 1 kHz, rated output	
Inputs	Six input ports: Each port accepts any input module except T-01S. Use T-01S only in port 5 or 6. One bridging input/output.	
Input Sensitivity/Impedance	Input ports 1 to 6: 100 mV, 10 k $\Omega$ Bridging input/output: 100 mV, 3.3 k $\Omega$	
Outputs	(T): 8 $\Omega$ , 25 V and 70 V, balanced (D): 4 $\Omega$ , unbalanced	
Output Regulation (1 kHz)	(D): Less than 0.5 dB, no load to full load. (T): Less than 1.0 dB, no load to full load.	
Signal to Noise Ratio (Band Pass: 20 Hz – 20 kHz)	Controls OFF: 90 dB Master volume Max: 77 dB Equalizer IN: 88 dB Compressor IN: 84 dB	
Compression	Attack time: Not greater than 2 ms Compression range: 20 dB Release time: Adjustable 20 – 2000 ms Distortion: Less than 1%	
Equalization	9-Band ISO One-octave graphic equalizer Center frequencies: 63, 125, 250, 500, 1000, 2000, 4000, 8000, 16000 Hz Equalization range: $\pm 12$ dB	
Filters	High-pass filter: 180 Hz, 12 dB/octave Low-pass filter: 7 kHz, 12 dB/octave	
Controls	6 Input gain controls, 1 Master gain control, 1 Compression level control, 9 Equalizer controls, 1 Power ON/OFF switch, 1 Equalizer ON/OFF switch, 1 High-pass filter ON/OFF switch, 1 Low-pass filter ON/OFF switch, 1 Low-cut switch (60 Hz, 6 dB/octave, inside)	
Indicators	1 LED power indicator, 1 LED peak indicator	
Protection	Self-protection, with 2 AC fuses (1 inside) and 1 output fuse	
Connectors	Input 1 to 6: Card-edge connector Output: Screw-terminal strip Bridging input/output: Screw-terminal strip Mute: Screw-terminal strip AC Power cord: SJT 3-conductor	
Power Source	120 V AC, 60 Hz	
Power Consumption (1/3 Non-Clip Maximum Power)	100 W	180 W
Color	Silver	
Dimensions	Face panel: 412 (w) x 680 (h) x 28 (d) mm (16.22" x 26.77" x 1.10") BX-9F Back Box: 362 (w) x 628 (h) x 98 (d) mm (14.25" x 24.72" x 3.86") BX-9S Back Box: 412 (w) x 680 (h) x 98 (d) mm (16.22" x 26.77" x 3.86")	
Weight	13.7 kg (30.20 lb) (without input modules and back box)	17.3 kg (38.14 lb) (without input modules and back box)
Other Features	Output disconnect for approx. 5 sec after power turned on. Muting Function: Accomplished by input modules.	

### Notes

- The design and specifications are subject to change without notice for improvement.
- (D): Direct output, (T): Transformer output
- Power Bandwidth and Frequency Response are from input port to power amplifier output.

• **Accessories**

Volume control cover YA-910 .....	3	Machine screw M3 x 10 .....	4
Key (for door) .....	2	Flange nut for M3 .....	4
Lift-off hinge (receptacle) .....	2	Tapping screw 3 x 8 .....	4
Machine screw M4 x 10* .....	5	Inch screw .....	4
Machine screw M3 x 6 .....	6	Indication label .....	1

\* Three screws are actually used and extra two are spare.

• **Optional products**

Flush-mounting (in-wall) back box:	BX-9F
Surface-mounting (on-wall) back box:	BX-9S
Expanding kit:	WE-2
Volume control cover (black):	YA-910

**13. BLOCK DIAGRAM**

