



ELECTRIC LIFT & TILT MOBILE STAND

FPS2/ELT/GG



Take control of creative, presentation and collaboration work spaces.

Salamander's beautiful and highly functional FPS Series Mobile Stands offer superior ergonomics complimenting any touch screen display with improved productivity, unrivaled flexibility and lifetime value.

Get perspective with table mode, then use the electric lift to quickly focus on work in drafting mode then collaborate with presentation mode.

A stylish, sleek and compact design moves easily between spaces. A thoughtful range of accessories provides even more utility and an improved user experience.

- Mobile stand for interactive display / touchscreen panel
- Motorized electric lift and tilt and wired remote with independent lift/tilt control
- Compatible with most large displays including 70" Screens and Microsoft Surface Hub 2, see VESA pattern and weight limits.
- *Note: Some display panels are not designed for horizontal or drafting positions. Check display manufacturer for details.*
- Ergonomic design. Adjustable height and tilt positioning provides best possible ergonomics and viewing.
- Range of travel, Center of screen: Min - 33.33" (847 mm) and Max 58.92" (1497 mm)
- Superior mobility. High quality, commercial grade locking casters and integrated handles provide easy maneuverability and transport
- Fully concealed cable management allows clean and uncluttered installation
- Storage for electronic components, peripherals and accessories.
- Telescopic design allows compact position for transport and storage
- Durable construction. Made in USA of powder coated steel, Linak Motor components, Powder coated and/or veneered MDF panels
- Options available for peripheral equipment mounting, retractable cable reel, secure equipment storage cover, keyboard tray and more.
- Limited Lifetime Warranty



ELECTRIC LIFT & TILT MOBILE STAND

FPS2/ELT/GG

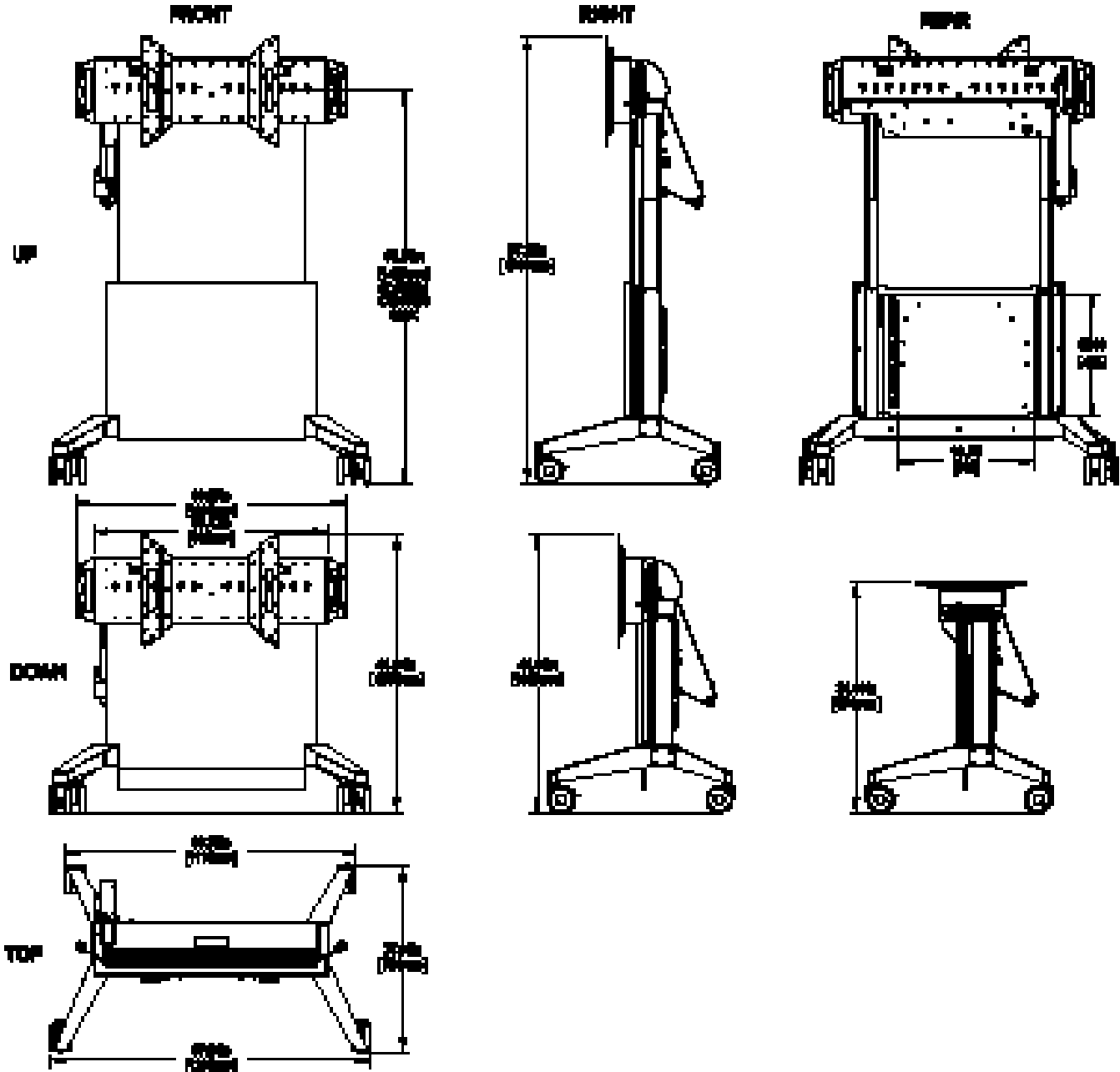



ELECTRIC LIFT & TILT MOBILE STAND

FPS2/ELT/GG

PRODUCT SPECIFICATIONS	Metric (mm)		US/Imperial Inches		SHIPPING DIMENSIONS	
Length	1215.2	47.84	1,219 mm	48 inch		
Overall Height Range	1057.5 - 1707.5	41.63 - 67.22	1,016 mm	40 inch		
Center of Screen Range of Travel	846.6 - 1496.6	33.33 - 58.92				
Depth	695.4	27.38	406 mm	16 inch		
Weight	65.77 kg	145 lbs	79.4 kg	175 lbs		
Max Load Capacity	79.38 kg	175 lbs				
UPC Number	634878507127					

VESA COMPLIANT MOUNT PATTERN

Horizontal - 200, 250, 300, 350, 400, 450, 500, 550, 600, 650, 700, 750, 800, 850, 900mm
 Vertical - 100, 200, 300, 350, 400mm
 Panel Mounting - M4, M5, M6 Screws

Supports Microsoft Surface Hub 2
 (VESA 350mm x 350m)

CASTER WHEELS

4" (100mm) HD, Non Marking, Brakes on 2

ELECTRICAL INFORMATION

Input: 90V - 240V ~, 48 Hz - 63HZ
 Duty Cycle: 10% Max 2min / 18min

CABLE MANAGER CHAIN

1" x .75" x 34" (25 x 19 x 865mm)

POWER CABLE

IEC - Type Class 2, 2-prong
 USA Included: (PN 400-590)

Available:
 EU (PN 400-591)
 UK (PN 400-592)
 New Zealand, Australia and others (PN 400-593)





ELECTRIC LIFT & TILT MOBILE STAND

FPS2/ELT/GG

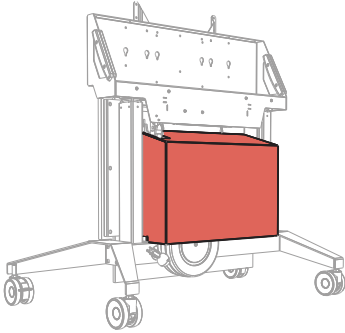

Equipment Storage Cover- Graphite
FPSA/SC/GT

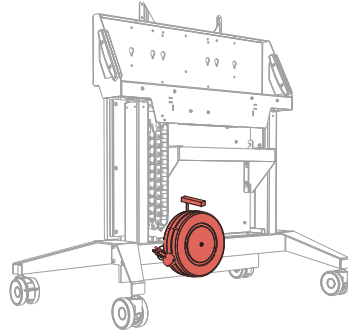

Cable Reel 30' Payout, 24" Tri-Tap Female End
FPSA/CR

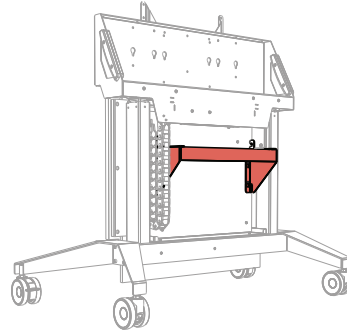

19" Rack Mounting 3 RU
RM/VR/3U

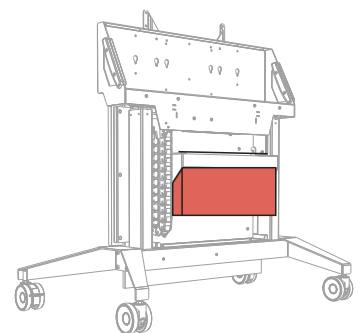

Power Distribution Unit
SA/RM/PDU

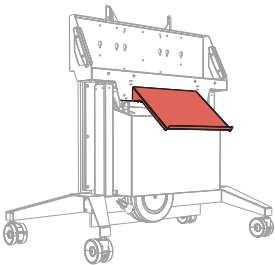

Keyboard Storage Shelf- Graphite
FPSA/KS/GT

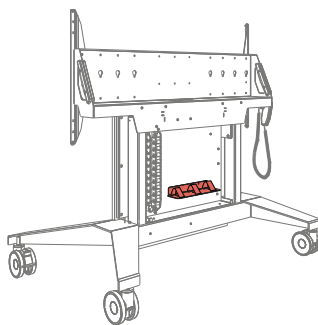

Accessory Shelf with Straps
FPSA/AS1

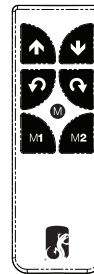

Wireless RF Remote Control with Memory
FPSA/RF1

ROAD CASE

FOR EASY DEPLOYMENT

Combine a mobile stand with a road case to provide secure and convenient transport of your display.

Accommodates Stand & Display

FPSA/RC/ELT

