



USER MANUAL

EZ-TOUCH SERIES

MANUAL LIFT WALL MOUNTS

EZ1/ML145

Consists of:

EZ1/MB16/152 Mount Body
EZ1/MA1 VESA Bracket

Displays up to **79-140 lbs (36-64 kg)**

VESA Mounting: 200 x 200 – 800 x 670

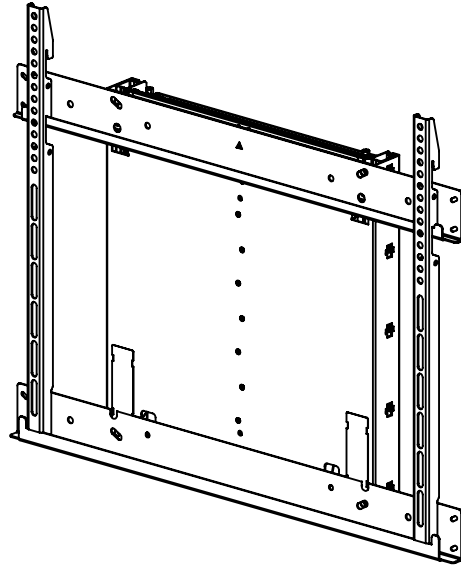

EZ1/ML209

Consists of:

EZ1/MB16/209 Mount Body
EZ1/MA1 VESA Bracket

Displays up to **134-197 lbs (61-90 kg)**

VESA Mounting: 200 x 200 - 800 x 670

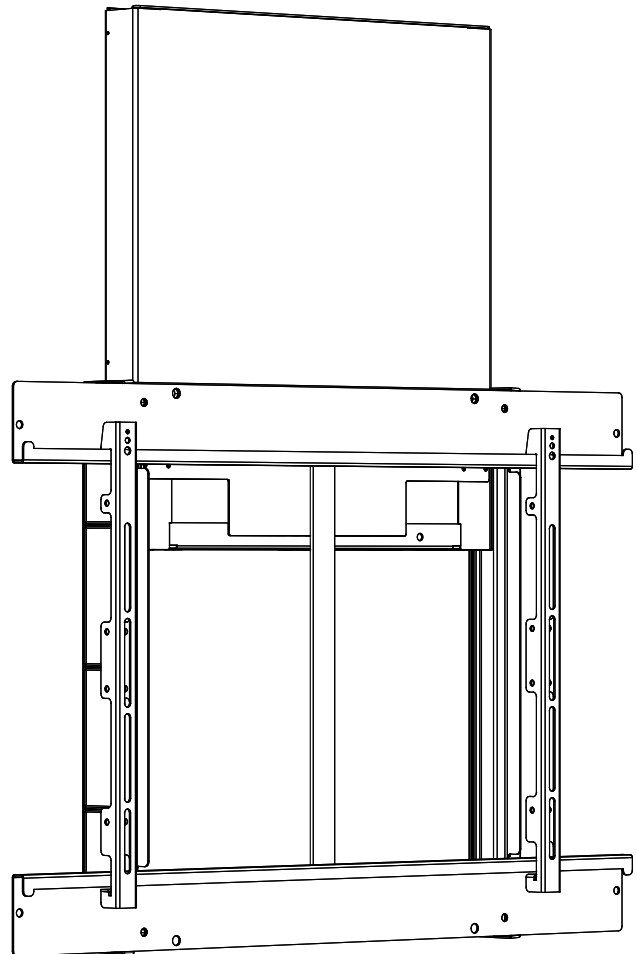

EZ1/ML095

Consists of:

EZ1/MB16/095 Mount Body
EZ1/MA5 VESA Bracket

Displays up to **41-85 lbs (18-38 kg)**

VESA Mounting: 200 x 100 - 800 x 440



PARTS - EZ1/ML145 / EZ1/ML209 / EZ1/ML095

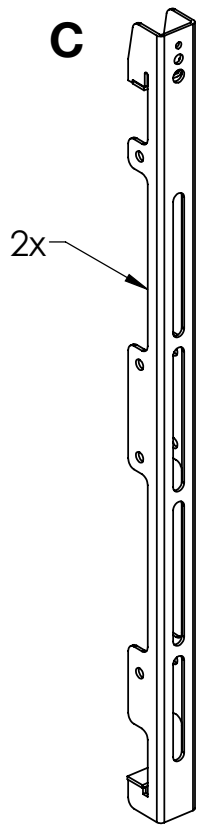
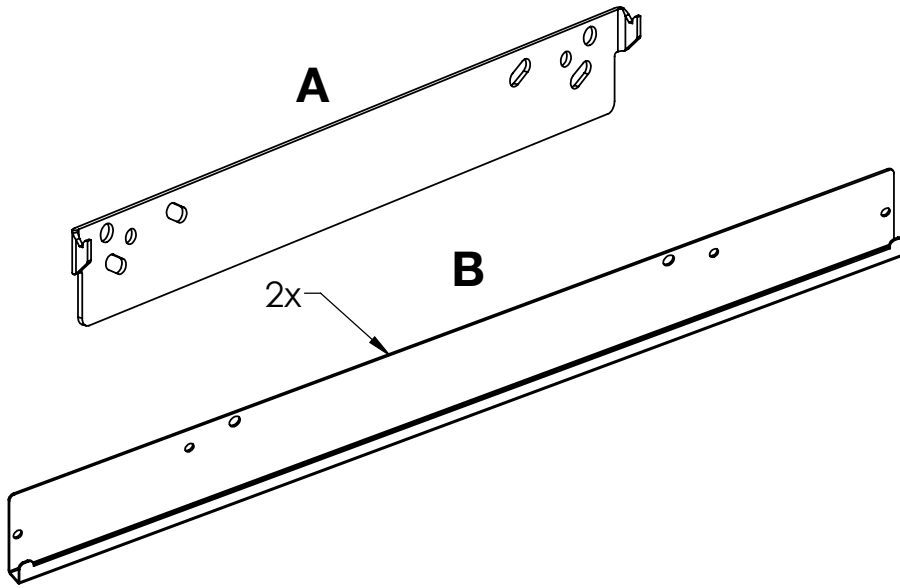

Bracket for ML095



Bracket for ML145 & ML209

D - Bag



M6 Washer (4x)

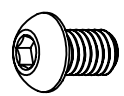

M6 x 10mm (10x)

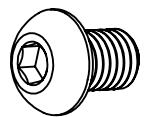

M8 x 12mm (4x)

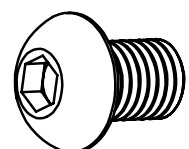

M10 x 20mm (5x)

E - Bag



M6 Washer (4x)

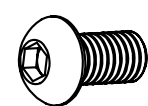

M6 x 12mm (6x)

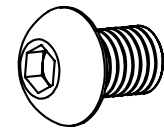

M8 x 20mm (4x)

How to use this manual

- 1 Read manual carefully before you install the mount
- 2 Carry out the actions fully and in the given sequence
- 3 The mount guarantee is voided if the product is not correctly installed or modified in any way

Warning symbols used

- A Sharp edges
- B Wear glove
- C Physical load
- D Two people required
- E Entanglement hazard
- F Warning: Can cause personal injury or equipment damage

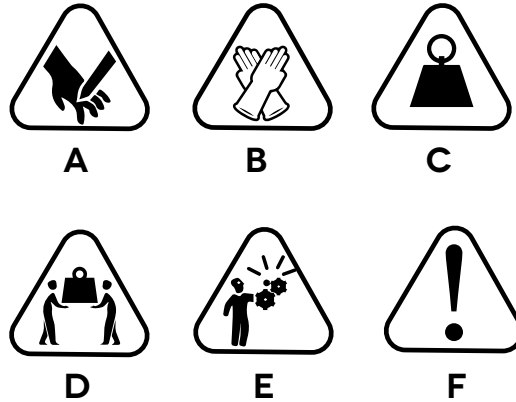

Intended use

The EZ-Touch Mount is a system that compensates the mass of vertically moving displays to ease vertical movement of the display.

General warning

The display may only be attached to or removed from the EZ-Touch when the EZ-Touch is in closed position. The EZ-Touch is under strong spring force. Only operate the EZ-Touch with an adequately balanced display attached to the display frame. Do not remove any parts of the EZ-Touch. Only the finishing cover can be removed.

Mounting fasteners

Mounting fasteners are not included with the product. Obtain advice from a specialist.

Setting the springs

Adjust only the outer springs:

- Adjust the height of the outer springs equally
- Make sure that the height of the display is balanced
- Increase the spring tension as much as possible
- Make sure that the display does not move up

Never adjust the inner springs

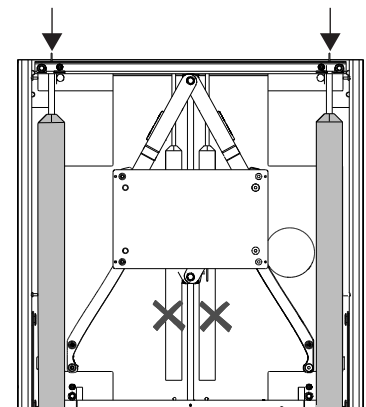

Disposal of the EZ-Touch

Springs should be unattached before disposal of the EZ-Touch. Sort the EZ-Touch, the accessories and the packaging for the environmentally friendly recycling.

Installation of EZ1/MB16/152 Mount Body

Prepare Mounting Site

The EZ-Touch was designed to be installed on a 16" on center 2" x 4" wood stud, or metal studs, using high-quality hollow wall anchor installed in the center of the stud or a solid concrete wall.



WARNING: INSTALLING THE MOUNT IN UNDERRATED OR DAMAGED CONCRETE CAN LEAD TO SERIOUS INJURY OR DAMAGE TO PRODUCT! When installing into concrete only install the mount in a solid concrete wall made of 2500 PSI (17.3 MPa) or stronger concrete. Never install the mount into cracked, chipped or flaking concrete.



WARNING: IMPROPER INSTALLATION CAN LEAD TO MOUNT FALLING CAUSING SERIOUS PERSONAL INJURY OR DAMAGE TO EQUIPMENT! It is the installers responsibility to make sure the structure to which the EZ-Touch is being installed is capable of supporting three times the combined weight of the EZ-Touch and all attached equipment is not to exceed the following weight capacities:

EZ1/MB16/152: 79-140lbs (36-64kg)

EZ1/MB16/209: 134-197lbs (61-90kg)

EZ1/MB16/095: 41-85lbs (18-38kg)

Mounting EZ-Touch Mount Body to Wall

Unpack the EZ-Touch and remove the plastic cover and two foam blocks.

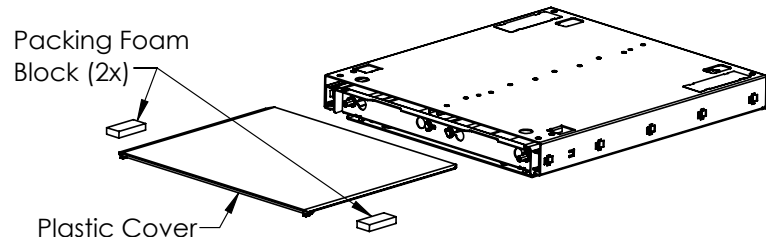
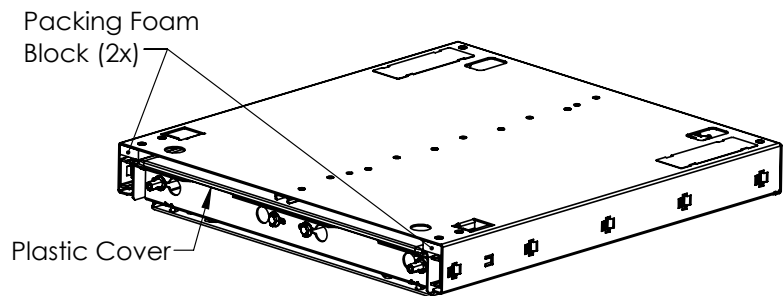

Locating your mount

WOOD CONSTRUCTION:

locate two framing studs (minimum of 16" (405 mm) apart) at the desired location using a stud finder device.

MASONRY:

a minimum width of 16" (405 mm) is required between fasteners.

Determine mounting height

See below for recommended mounting height for 55" Display. Other displays can be calculated by adding half the height difference to the top and half the height difference to the bottom of the example shown

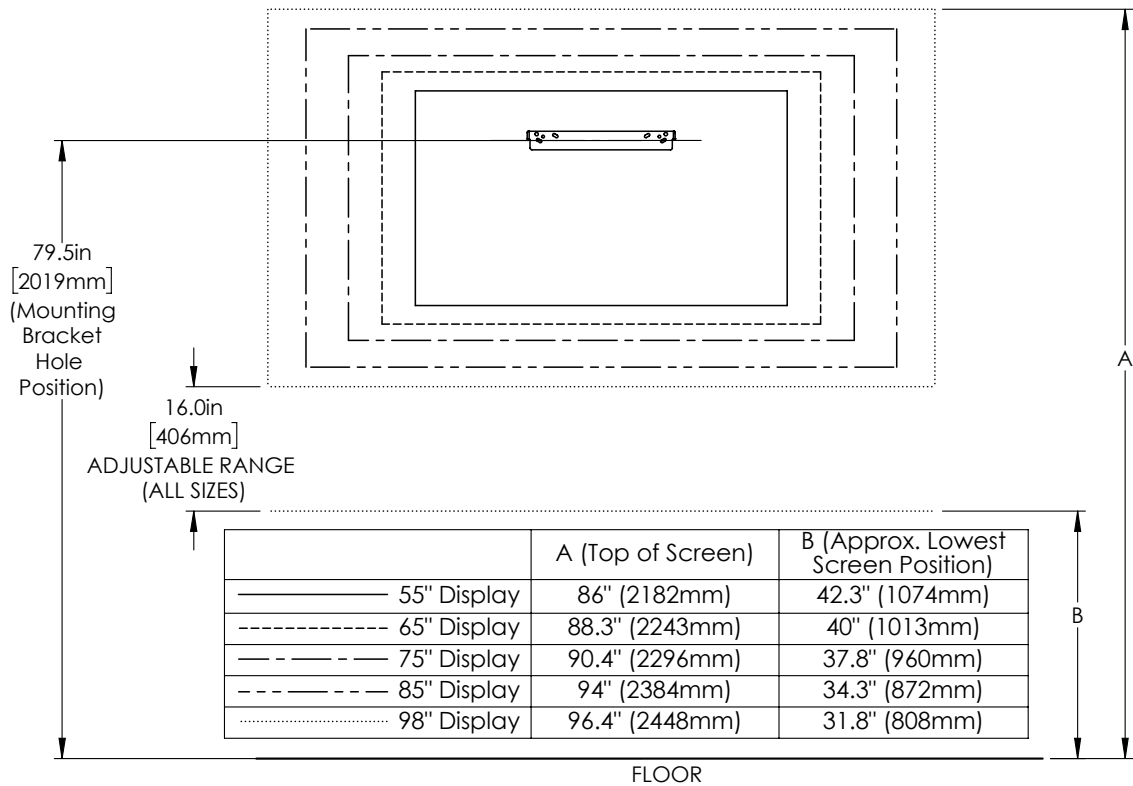

Mounting bracket level to wall

Unpack the EZ-Touch Take the wall bracket out (A) of the box. Note the slotted/slanted holes for level wall mounting.

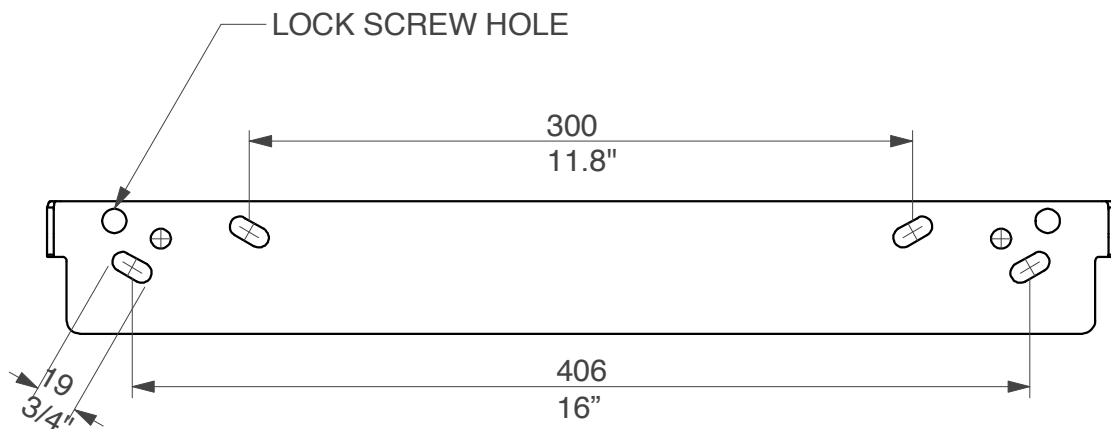

Make sure screws are unlocked

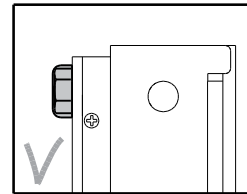
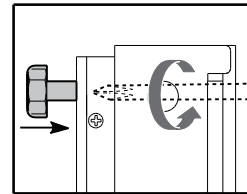
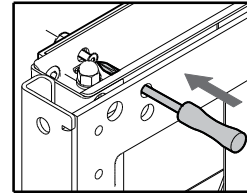
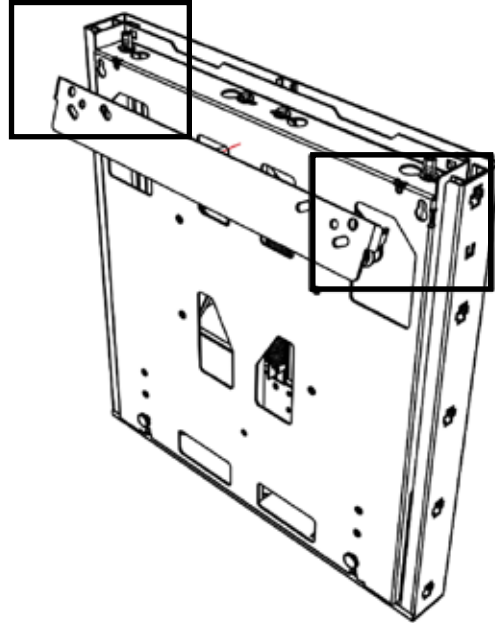

Touch the mount onto bracket

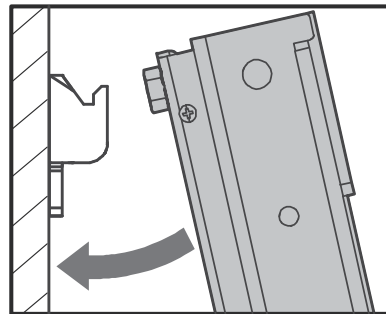
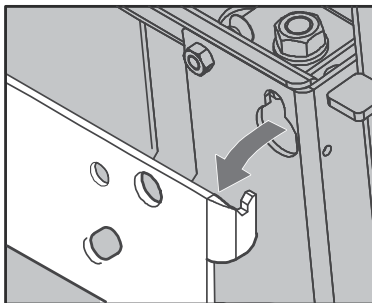

Lock mount with screws

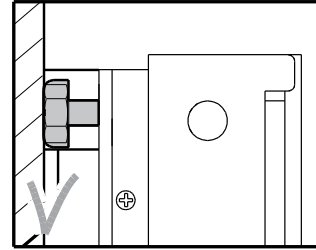
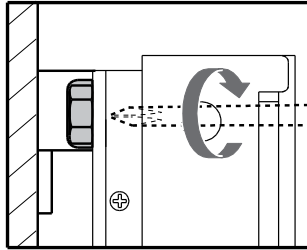
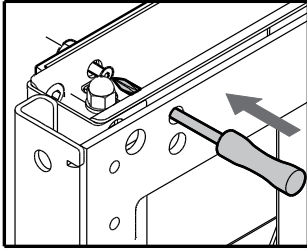

Level vertically with feet at the bottom

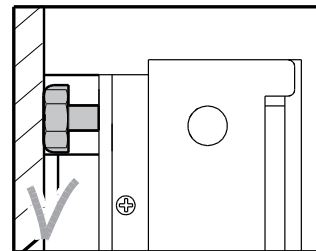
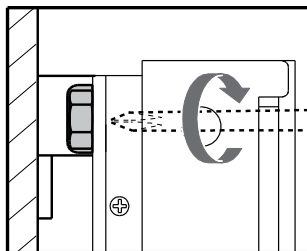
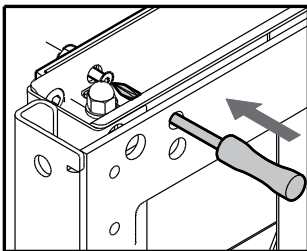
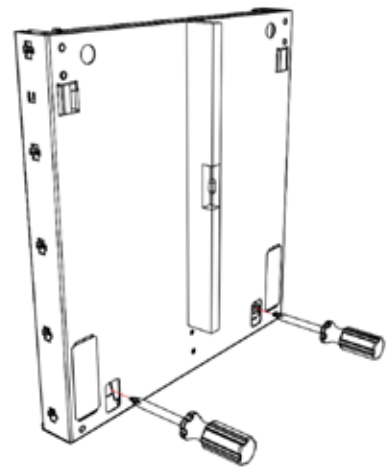
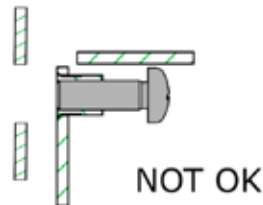
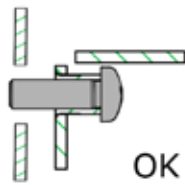
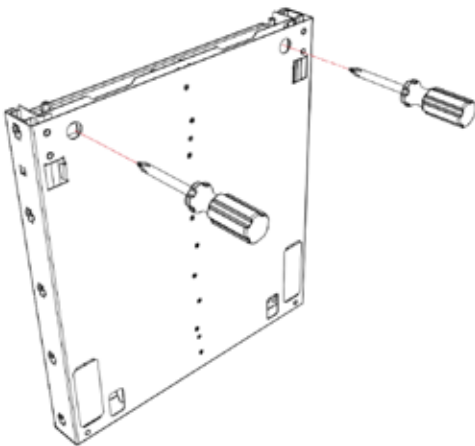

Insert plastic cover

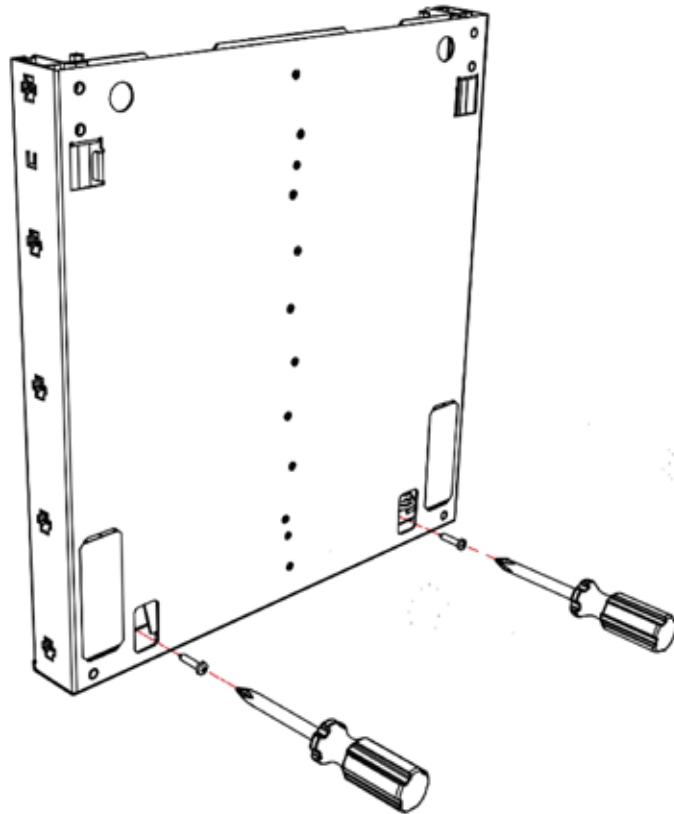
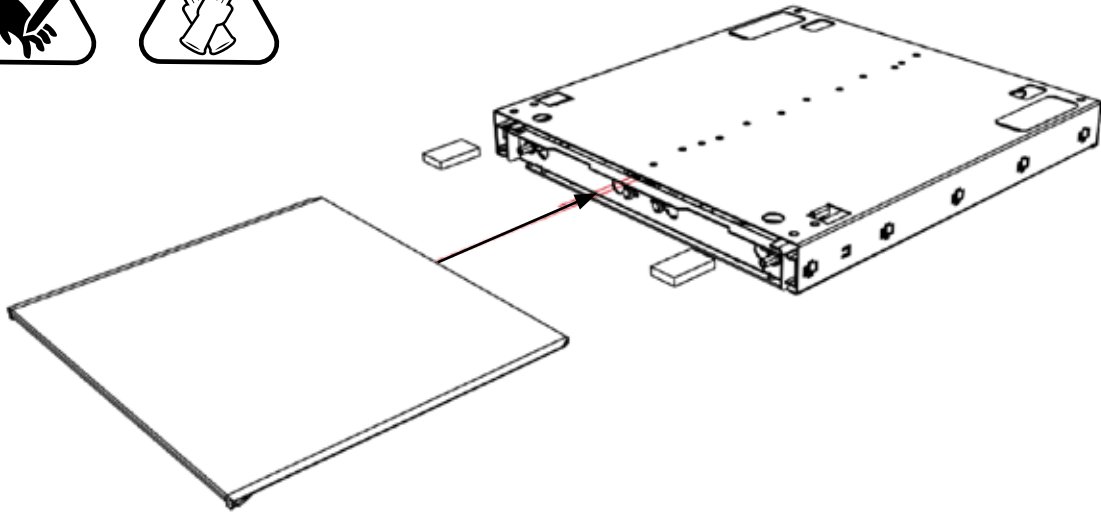

Attach brackets to mount and display

ML095

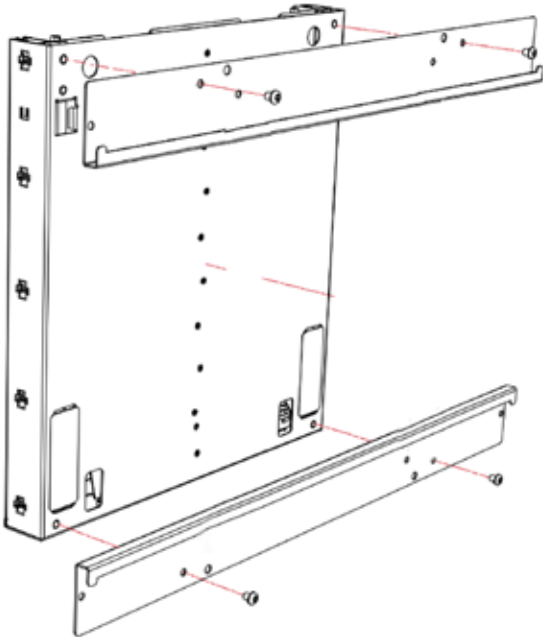

ML145 & ML209

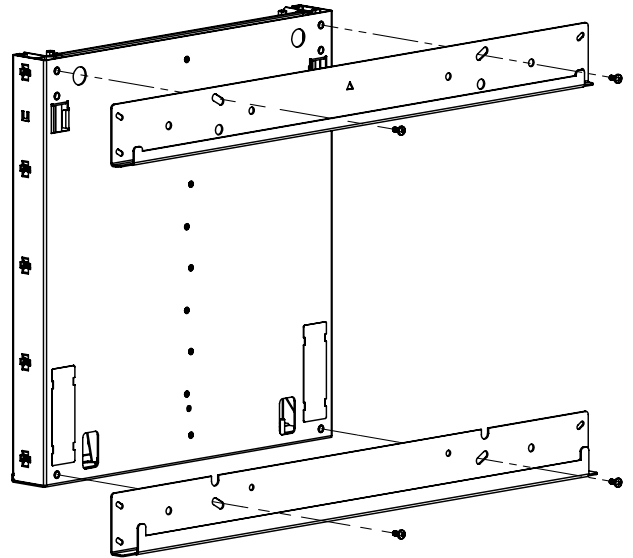

OR

M10 x 20mm (4x) or
M6 x 12mm (4x) or
M8 x 20mm (4x)

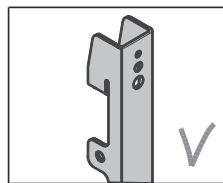
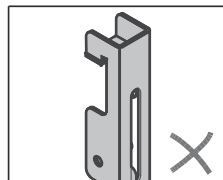
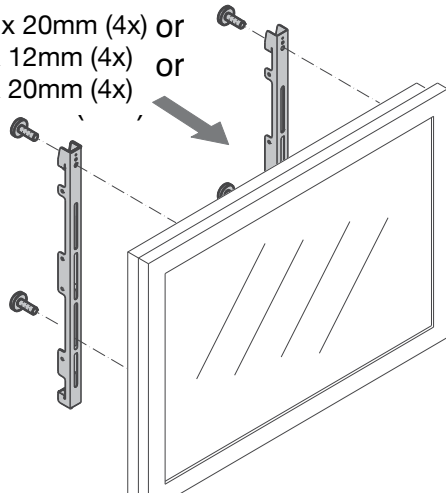

Warning

Must use M8 x 12mm screws in D-Bag.

Hang display onto horizontal bracket and level

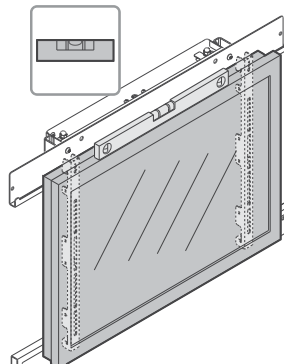
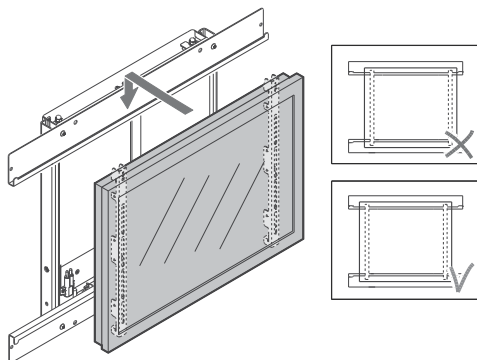

Lock display with safety lock screws from the bottom

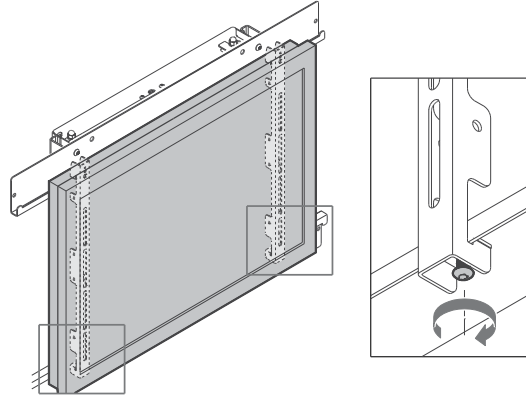

Set balance

Balancing: Springs are always fully tightened for safety. Use a drill driver and 1/2" (13 mm) socket, rotate counter clockwise (loosen) evenly. Do three seconds left and three seconds right until the mount is evenly balanced to support display weightlessly.

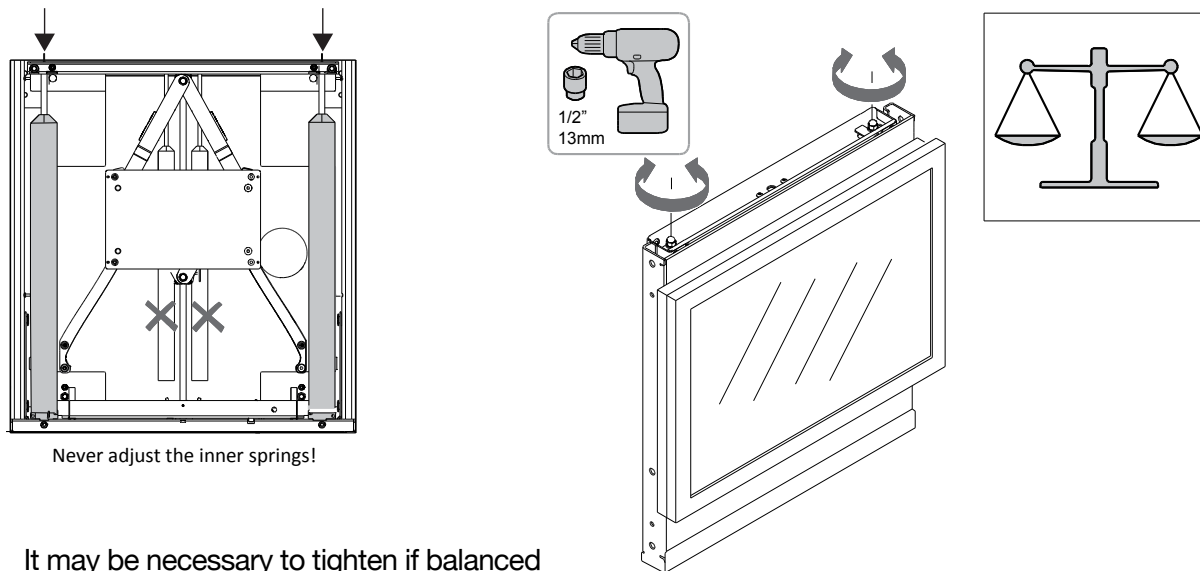

It may be necessary to tighten if balanced point is exceeded.



SALAMANDER WARRANTY LIMITED WARRANTY FOR COMMERCIAL VIDEO DISPLAY STANDS AND MOUNTS

Salamander warrants against manufacturing defects for two (2) years from the date of purchase. Salamander will repair or replace, at our option, any product defective in materials or craftsmanship. Batteries are not covered by the warranty.

Full warranty including limitations and warranty claim information may be found at www.salamandercommercial.com

Subject to printing errors and technical amendments.