

# Planar QE Series User Manual



Copyright © 01/01/2017 by Planar Systems, Inc. All rights reserved.

Contents of this publication may not be reproduced in any form without permission of Planar Systems, Inc.

### Trademark Credits

Windows™ is a trademark of Microsoft Corp.

All other companies are trademarks or registered trademarks of their respective companies.

### Disclaimer

The information contained in this document is subject to change without notice. Planar Systems, Inc. makes no warranty of any kind with regard to this material. While every precaution has been taken in the preparation of this manual, the Company shall not be liable for errors or omissions contained herein or for incidental or consequential damages in connection with the furnishing, performance, or use of this material.

### Warranty and Service Plans

Planar warranty and service plans will help you maximize your investment by providing great support, display uptime, and performance optimization. From post-sale technical support to a full suite of depot services, our services are performed by trained Planar employees. When you purchase a Planar product, you get more than a display, you get the service and support you need to maximize your investment. To find the latest warranty and service information regarding your Planar product, please visit <http://www.planar.com/support>

Part Number: 020-1320-00A

# Contents

<b>Introduction</b>	1
Safety Information	2
Safety Precautions	2
Recommended Usage	4
Mounting with a VESA Mount	6
Cleaning the Display	6
<b>Package Contents</b>	7
<b>Standard Inputs</b>	9
Planar QE Series Displays	9
Embedded Planar ContentSmart Media Player	10
<b>Installing the Displays</b>	11
Before You Begin	11
Supported Graphics Cards	12
<b>Operating the Display</b>	13
OSD Keypad	13
Remote Control Receiver	14
LED Indicators	15
Using the Display in Portrait Mode	15
Using the Display in Flat or Tilted Orientation	15
Using the Remote Control	16
IR Command Protocol	17
Turning the Display On	20

Turning the Display Off.....	20
Adjusting the Volume .....	21
Selecting Layouts and Input Sources.....	21
Navigating Through the Menus.....	22
Using the Touch Screen .....	47
<b>Embedded Planar ContentSmart .....</b>	<b>48</b>
Feature Highlights .....	48
Loading Content.....	48
Configuring the Player .....	49
Content Management.....	78
Authoring in HTML5.....	78
Working with SMIL .....	78
<b>Planar QE Series Remote Monitoring Software .....</b>	<b>79</b>
Remote Monitoring Home.....	79
Remote Monitoring System Information .....	79
Remote Monitoring Inputs and Views.....	80
Remote Monitoring Audio.....	81
Remote Monitoring Panel Brightness and Power .....	82
Remote Monitoring Notifications .....	83
Remote Monitoring System Settings.....	84
Remote Monitoring Access Control .....	85
<b>External Control .....</b>	<b>86</b>
<b>Signal Compatibility .....</b>	<b>87</b>
<b>Color Subsampling Support .....</b>	<b>90</b>
<b>Specifications.....</b>	<b>91</b>

---

Embedded Planar ContentSmart Specifications .....	93
<b>Dimensions</b> .....	94
QE7550 .....	94
QE7550 Touch .....	95
QE8650 .....	96
QE8650 Touch .....	97
QE9850 .....	98
QE9850 Touch .....	99
<b>Troubleshooting During Installation</b> .....	100
Error Codes .....	100
Symptoms, Possible Causes and Solutions .....	101
<b>Accessing Planar's Technical Support Website</b> .....	105



# Introduction

Offered in sizes ranging from 75" to 98", the Planar® QE Series is the first of its kind family of displays that offer an end-to-end affordable display solution for designing, scheduling, distributing, and playing back digital signage content in ultra-high resolution. Featuring embedded Planar® ContentSmart™ 4K media player and software, the Planar QE Series provides a simple and cost-effective way to create digital signage messaging for a single display or multiple displays within a network, dramatically reducing installation cost and complexity.

With cutting edge 4K @ 60Hz support through DisplayPort 1.2 and HDMI 2.0, single- or quad-source viewing, and multiple display control options, the Planar QE Series is also ideal for collaborative meeting spaces when paired with a compatible source. For those seeking to collaborate or annotate using a large viewing area, multi-touch models are also available. Each touch display ships with Planar® TouchMark™, the premier collaboration solution for annotation and whiteboarding needs.

Featuring a logo-free bezel, the Planar QE Series is perfect for use in retail stores, restaurants, medical offices, corporate meeting areas, huddle rooms and hospitality. Designed for up to 24 x 7 operation in commercial installations, the Planar QE Series is backed by Planar's industry-leading 3-year warranty. Featuring LED backlight technology, the Planar QE Series displays operate at lower power, reducing total cost of ownership. From its comprehensive set of inputs and control to its easy to use embedded media player, the Planar QE Series LCD displays redefine affordable 4K displays with features including:

- Sizes ranging from 75" to 98"
- Ultra HD resolution (3840 x 2160) LCD displays
- Embedded Planar ContentSmart media player and software for quick and easy design, deployment and management of 4K content
- Cutting edge video performance supporting up to 4K @ 60Hz
- Fully integrated multi-touch models available
- Fanless, whisper-quiet

## Safety Information

Before using the Planar QE Series, please read this manual thoroughly to help protect against damage to property, and to ensure personal safety.

- Be sure to observe the following instructions.
- For your safety, be sure to observe ALL the warnings detailed in this manual.
- For installation or adjustment, please follow this manual's instructions, and refer all servicing to qualified service personnel.

## Safety Precautions

- **If water is spilled or objects are dropped inside the display, remove the power plug from the outlet immediately.** Failure to do so may result in fire or electrical shock. Contact your dealer for inspection.
- **If the display is dropped or the chassis is damaged, remove the power plug from the outlet immediately.** Failure to do so may result in fire or electrical shock. Contact your dealer for inspection.

**WARNING!** Wall mounts must be secure.

- **If the display is hung on a wall, the wall must be strong enough to hold it.** Simply mounting it to wallboard or wall paneling won't be adequate or safe.

**Caution:** The screen could be damaged by heavy pressure.

- **Slight pressure on the LCD will cause distortion of the image.** Heavier pressure will cause permanent damage. Displays should be mounted where viewers cannot touch the screen or insert small objects in the openings that will create hazards by contacting bare conductive parts.

**Caution:** The front polarizer is soft and subject to scratches from sharp objects.

- **The polarizer is a thin sheet of film laminated to the outside layer of glass on the LCD screen.** Take care when handling items near the screen.
- **If the power cord or plug is damaged or becomes hot, turn off the main power switch of the display. Make sure the power plug has cooled down and remove the power plug from the outlet.** If the display is still used in this condition, it may cause a fire or an electrical shock. Contact your dealer for a replacement.



## Important Safety Instructions

- 1** Read these instructions.
- 2** Keep these instructions.
- 3** Heed all warnings.
- 4** Follow all instructions.
- 5** Do not use the display near water.
- 6** Clean the LCD screens with an LCD screen cleaner or LCD wipes.
- 7** Do not install near any heat sources such as radiators, heat registers, stoves or other apparatus (including amplifiers) that produce heat.
- 8** Do not defeat the safety purpose of the polarized or grounding type plug. A polarized plug has two blades with one wider than the other. A grounding type plug has two blades and a third grounding prong. The wide blade or the third prong is provided for your safety. When the provided plug does not fit into your outlet, consult an electrician for the replacement of the obsolete outlet.
- 9** Protect the power cord from being walked on or pinched, particularly at plugs, convenience receptacles and the point where they exit from any of the displays.
- 10** Only use the attachments/accessories specified by the manufacturer.
- 11** Unplug all displays during lightning storms or when unused for long periods of time.
- 12** You must follow all National Electrical Code regulations. In addition, be aware of local codes and ordinances when installing your system.
- 13** Refer all servicing to qualified service personnel. Servicing is required when any of the displays have been damaged in any way. For example, if the AC power cord or plug is damaged, liquid has been spilled or objects have fallen into a display, the displays have been exposed to rain or moisture, do not operate normally or have been dropped.
- 14** Keep the packing material in case the equipment should ever need to be shipped.

## Recommended Usage

In order to get the most out of your LCD, use the following recommended guidelines to optimize the display.

### Burn-In Versus Temporary Image Retention

Burn-in causes the screen to retain an image essentially forever, with little or no way to correct the problem. Under normal use, an LCD will not experience burn-in, as plasma displays do, nor will it retain images in any way.

Normal use of an LCD is defined as displaying continuously changing video patterns or images. However, LCDs can experience *temporary* image retention when recommended usage guidelines are not followed.

#### What is Temporary Image Retention?

Temporary image retention (TIR) can occur when a static image is displayed continuously for extended periods of time (12 hours or longer). An electrical charge differential may build up between the electrodes of the liquid crystal, which causes a negative-color video image (color-inverted and brightness-inverted version of the previous image) to be retained when a new image is displayed. This behavior is true for any LCD device from any LCD manufacturer.

TIR is not covered under warranty. See standard warranty terms and conditions for details. Here are some guidelines to help you avoid TIR:

- Use the LCD to show a screen saver, moving images or still pictures that change regularly. When using high-contrast images, reposition the images frequently.
- Turn off the LCD when it is not in use. To use your source computer's Power Options Properties, set up your computer to turn off the display when not in use.

### Warranty Coverage

The following models are warranted for **24 x 7** usage:

- 75": QE7550, QE7550T
- 86": QE8650, QE8650T
- 98": QE9850, QE9850T

Planar recommends turning off the power for **4 hours per day** for optimal performance.

For complete warranty details, please visit [www.planar.com/warranty](http://www.planar.com/warranty).

## Important Waste Disposal Information

Please recycle or dispose of all electronic waste in accordance with local, state, and federal laws. Additional resources can be found online at <http://www.planar.com/about/green/>.

The crossed-out wheelee bin symbol is to notify consumers in areas subject to Waste Electrical and Electronic Equipment (WEEE) Directive 2012/19/EU that the product was placed on the market after August 13, 2005 and must not be disposed of with other waste. Separate collection and recycling of electronic waste at the time of disposal ensures that it is recycled in a manner that minimizes impacts to human health and the environment. For more information about the proper disposal of electronic waste, please contact your local authority, your household waste disposal service, or the seller from whom you purchased the product.



## Normal Usage Guidelines

Normal use of the LCD is defined as operating in the open air to prevent heat buildup, and without direct or indirect heat sources such as lighting fixtures, heating ducts, or direct sunlight that can cause the displays to experience high operating temperatures. For all displays, do not block fans or ventilation openings. If the LCD display will be installed in a recessed area with an LCD surround or enclosure, ensure adequate openings are applied for proper air flow and ventilation.

It is up to the installer to ensure that display placement is changed, thermal shielding is provided and/or additional ventilation is provided to keep the display within its nominal operating parameters. Maximum ambient operating temperatures for the Planar QE Series are:

- 75", 86" and 98" Planar QE Series models: 0-35°C at up to 1500 meters and 0-30°C at up to 3000 meters

### Cooling Requirements

For optimal performance, active cooling by the installer should be planned for when the ambient temperature anywhere in the wall is predicted to be above the specified ambient temperature for the display.

## Mounting with a VESA Mount

VESA mounts are used to secure the Planar QE Series for display. The display can be installed using a variety of VESA mounts available through Planar. If you do not have a VESA mount and would like to purchase one, contact Planar.

If you purchased a VESA mount, you should have received a separate box with mounting supplies and an Installation manual. Follow these instructions carefully.

Keep in mind the following general installation guidelines:

- Screw length is crucial and will vary depending on the type of mount you use. Total screw length will include the penetration length plus the length required by the type of VESA mount in use.

**Caution:** Shorter screws will result in insufficient mounting strength and longer screws could puncture parts inside the display.

- Prior to installation, make sure you know where all of the mounting points are located.
- Follow all safety precautions outlined in the VESA Installation manual.
- Verify the parts received with the list shown in the VESA Installation manual.

## Cleaning the Display

If dust has collected on the power plug, remove the plug from the outlet and clean off the dust. Dust build-up may cause a fire.



Remove the power plug before cleaning. Failure to do so may result in electrical shock or damage.

Keep the following points in mind when cleaning the surface of the display:

- When the surface of the display becomes dirty, wipe the surface lightly with a soft clean cloth.
- If the surface requires additional cleaning, use LCD screen cleaner or LCD wipes, which are available at most electronics stores.
- Do not let cleaner seep into the display, as it may cause electrical shock or damage.

# Package Contents

Part	Description	Number Included	Picture
LCD display	One per box.	1	
AC power cord	Power cord.	1	
IR sensor	Used to receive signals from the remote control.	1	
USB drive	Contains the User Manual, touch drivers and USB-to-serial driver.	1	
USB cable	Connects to a PC for touch functionality (touch models only) and serial commands (all models).	1	

Part	Description	Number Included	Picture
Remote control	Used to control the display. 2 AA batteries are included but not installed.	1	
Planar® TouchMark™ Single License Key Card	Annotation and whiteboarding software (touch models only)	1	

# Standard Inputs

## Planar QE Series Displays

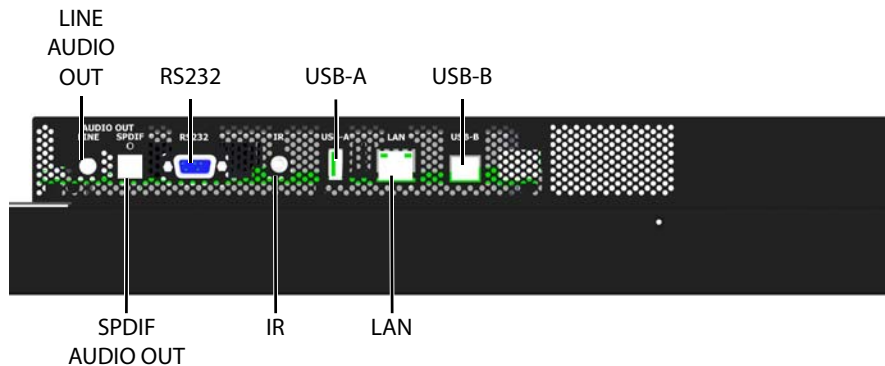
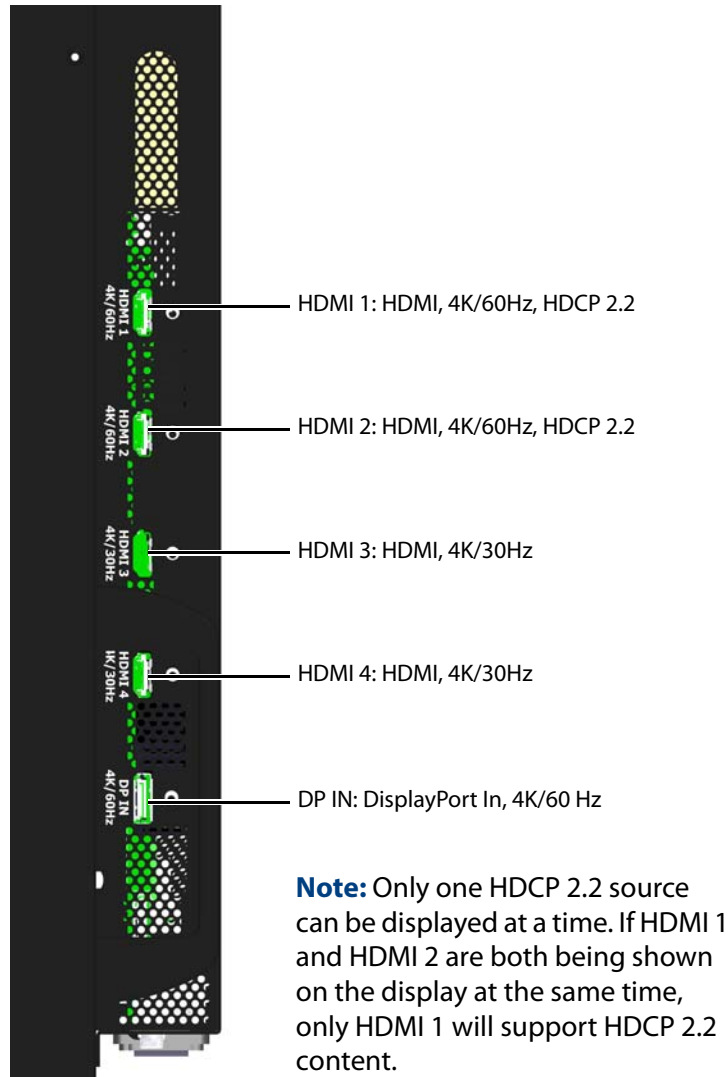

# Embedded Planar ContentSmart Media Player





# Installing the Displays

This section explains how to install your display. We suggest that you read the entire section before you attempt to install the unit.

## Before You Begin

Make sure to have all the items in these lists before beginning to unpack and install your display(s).

### Tools/Equipment List

Depending on your installation, you may need one or more of the following items:

- String/string level
- Digital/laser level
- Ladders/lift
- Back brace
- Stud finder (if hanging display on a wall)

### Other Things You May Need

- LCD screen cleaner or LCD wipes - available at most electronics stores
- At least two very strong people to help lift units into place

### Plan Your Installation

You should have a detailed plan of how the units are to be configured. The plan should include calculations for the following:

- Power (maximum of five units per 20A circuit for 115V operation)
- Cable runs
- Ventilation and cooling requirements
- If hanging display on a wall, location of studs in the wall

### Prepare Your Installation Location

You should have prepared the area where you will install the unit. If custom enclosures are part of the installation, they must be fully designed to accommodate the installation of the displays, as well as the installed unit and ventilation and cooling requirements.

If your installation included a lot of construction or dust, it is **highly recommended** that you clean all of the screens after the wall installation and configuration are complete.

## Cable Length Recommendations

Cable length performance may vary between different cables and sources. The recommended maximum DisplayPort length is 3m for DisplayPort 1.2 and 5m for DisplayPort 1.1. HDMI cable length is recommended as follows:

- 4K @ 50/60Hz: 5m maximum
- 4K @ 24/25/30Hz: 15m maximum
- 1080p @ 60Hz and lower resolutions: 30m maximum

## Supported Graphics Cards

Planar QE Series displays support a variety of graphics cards from leading manufacturers, such as NVIDIA and AMD. In general, you should be looking for graphics cards that have the following features:

- Can output 3840 x 2160 at 24 Hz, 30 Hz or 60 Hz over a single DisplayPort or HDMI connection.
- Four-output graphics cards that can output synchronized (genlocked) 1920 x 1080 outputs at up to 60 Hz.
- Cards that support Planar's support timings, as listed in the following section "Signal Compatibility" on page 87.

**Caution:** Before you purchase a graphics card for your source, contact your Sales Representative to get the most current information on Planar's compatibility with leading graphics cards.

# Operating the Display

## OSD Keypad

The OSD keypad is located on the rear of the display.

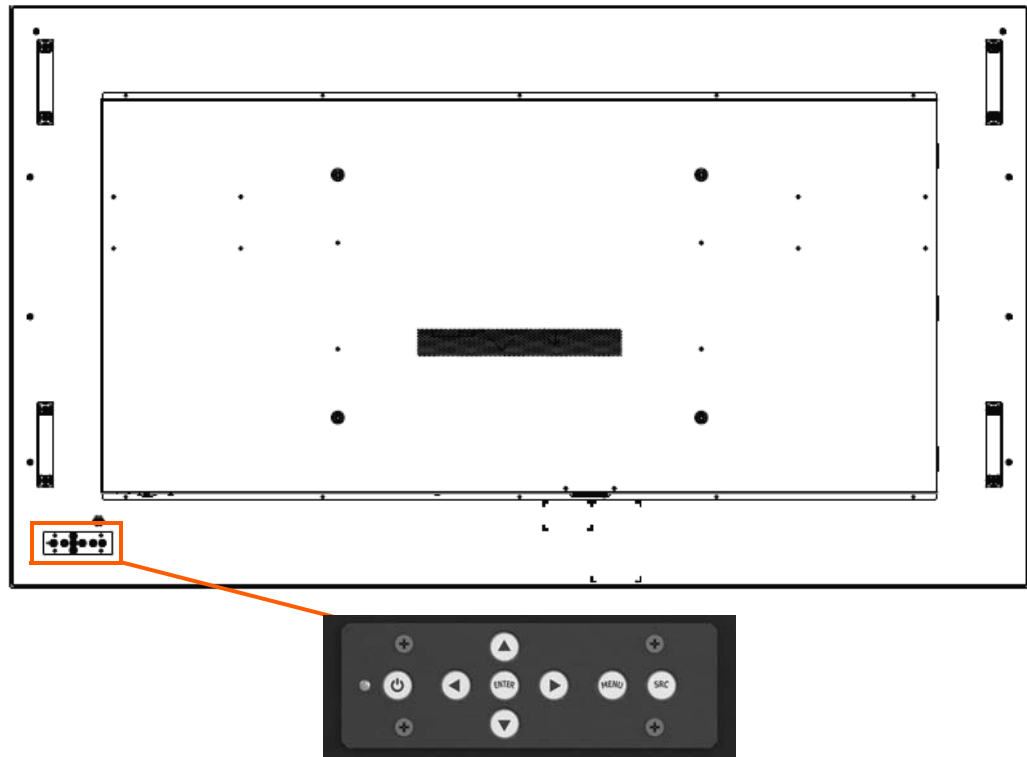

### OSD Keypad Buttons

Key	Descriptions
Power	Power on/Power off
◀	Menu Left/Decrease value
▶	Menu Right/Increase value
▲	Menu Up/Increase volume
▼	Menu Down/Decrease volume
Menu	Menu/Exit
SRC	Source selection (toggle)

## Remote Control Receiver

The remote control receiver is located near the keypad on the rear of the display. Use the IR extender cable for operating the remote from the front of the display.

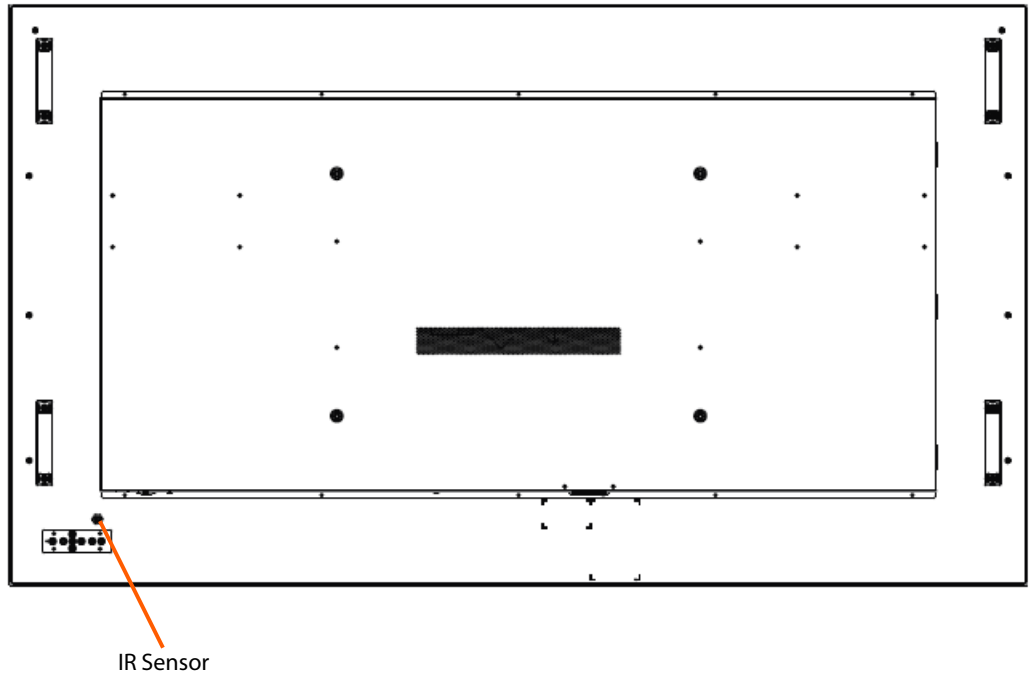

## LED Indicators

The LED indicator light is located on the rear of the display near the keypad. The following table explains what the different colors and blink patterns mean.

**LED On**

Power Status	Condition
Green	Standby mode
Amber	Full power mode
Green Flashing (1 Hz)	AC power on
Green Flashing (0.5 Hz)	Powering on from standby
Green Flashing (5 Hz)	Firmware updating
Amber Flashing (5 Hz)	Power supply failure
Green and Amber	Firmware update failure

## Using the Display in Portrait Mode

When using the display in the portrait position and looking at the rear of the display, it should be rotated according to the arrow stickers on the back of the display. This will allow for proper ventilation. Then select the OSD rotation of landscape or portrait on the OSD menu (MAIN MENU > ADVANCED SETTINGS > MENUS AND MESSAGES > OSD ROTATION).

**Caution:** Improper ventilation may shorten the life of the display.

## Using the Display in Flat or Tilted Orientation

The display is not recommended for use in flat orientation for tabletop, floor, or ceiling installations. LCD panels of this size are at risk of panel deflection, which can cause cosmetic sagging, brightness uniformity issues, a shortened life span, and malfunction of optional touch sensors. Installations where the display is tilted downward or upward at an angle may also be prone to these issues and are not recommended.

## Using the Remote Control

Below is a picture of the remote control. See the following page for button descriptions and Hex codes.



## IR Command Protocol

The Planar QE Series displays accept commands in the form of IR signals that conform to the NEC protocol. Each Planar QE Series remote control has an NEC control code associated with it. You can use these codes to program a third-party “universal” remote control to work with the Planar QE Series displays. These third-party products usually come with a computer software application for this purpose. For more information, consult the documentation provided with the remote control.

The IR control codes have the following characteristics:

- Each code consists of the following:
  - A leader pulse (a modulated pulse of 9 ms followed by a non-modulated pulse of 4.5 ms)
  - 16 address bits. The default address is 1785 (0x06F9, binary 0000011011111001)
  - 16 data bits: eight (8) bits for the command followed by the logical inverse of the command
  - An end pulse (a modulated pulse of 0.56 ms, similar to the modulated pulse in the ‘0’ and ‘1’ bits). The end of the modulated pulse constitutes the end of the data transmission.
- The carrier frequency is 38 kHz, with the modulated pulses having a 33% duty cycle.
- Commands are sent at a maximum rate of 9 Hz.

For example, below is the NEC control code for the ON button of the Planar QE Series remote control (assuming the default address is used).

Hex	06	F9	01	FE
Binary	00000110	11111001	00000001	11111110
Function	Address Byte 1	Address Byte 2	Command	Command (Logical Inverse)

The following example shows the pulse train for this command.



Remote Control Button Name	Address	Data	NEC Data From Remote (Hex Code)	Description
ON	1785	1	0x06F901FE	Power on
OFF	1785	9	0x06F909F6	Power off
◀	1785	2	0x06F902FD	Not used
▶	1785	3	0x06F903FC	Not used
**	1785	6	0x06F906F9	Not used
PRESETS	1785	4	0x06F904FB	Not used
PRESET 1	1785	5	0x06F905FA	Not used
PRESET 2	1785	7	0x06F907F8	Not used
PRESET 3	1785	8	0x06F908F7	Not used
PRESET 4	1785	10	0x06F90AF5	Not used
1	1785	12	0x06F90CF3	Number button 1
2	1785	13	0x06F90DF2	Number button 2
3	1785	14	0x06F90EF1	Number button 3
4	1785	15	0x06F90FF0	Number button 4
5	1785	16	0x06F910EF	Number button 5
6	1785	17	0x06F911EE	Number button 6
7	1785	20	0x06F914EB	Number button 7
8	1785	25	0x06F919E6	Number button 8
9	1785	27	0x06F91BE4	Number button 9
0	1785	18	0x06F912ED	Number button 0
VOL +	1785	28	0x06F91CE3	Volume increase
VOL -	1785	33	0x06F921DE	Volume decrease
MUTE	1785	32	0x06F920DF	Audio mute
COLOR	1785	19	0x06F913EC	Not used
VIDEO WALL	1785	34	0x06F922DD	Not used
MISC	1785	11	0x06F90BF4	Opens the Image Information menu
MENU	1785	21	0x06F915EA	Opens the menu
PREV	1785	22	0x06F916E9	Returns to the previous menu
ENTER	1785	23	0x06F917E8	Selects the current menu item
UP	1785	26	0x06F91AE5	Navigate up
DOWN	1785	29	0x06F91DE2	Navigate left
LEFT	1785	31	0x06F91FE0	Navigate right
RIGHT	1785	24	0x06F918E7	Navigate down



Remote Control Button Name	Address	Data	NEC Data From Remote (Hex Code)	Description
TOP	1785	30	0x06F91EE1	Selects the top line in the current menu
ZONE 1	1785	35	0x06F923DC	Selects the input for Zone 1
ZONE 2	1785	36	0x06F924DB	Selects the input for Zone 2
ZONE 3	1785	38	0x06F926D9	Selects the input for Zone 3
ZONE 4	1785	39	0x06F927D8	Selects the input for Zone 4
PIP MODE	1785	37	0x06F925DA	Selects the Multi-Source View setting
PIP SWAP	1785	40	0x06F928D7	Not used
HDMI 1	1785	41	0x06F929D6	Selects HDMI 1 for the current zone
HDMI 2	1785	42	0x06F92AD5	Selects HDMI 2 for the current zone
HDMI 3	1785	43	0x06F92BD4	Selects HDMI 3 for the current zone
HDMI 4	1785	44	0x06F92CD3	Selects HDMI 4 for the current zone
DP	1785	45	0x06F92DD2	Selects DP for the current zone
DVI	1785	46	0x06F92ED1	Not used
VGA	1785	47	0x06F92FD0	Not used
OPS	1785	48	0x06F930CF	Selects ContentSmart for the current zone

## Locking the Keypad and IR Remote

You can lock the keypad and IR remote functionality on the display. To lock the keypad, go to Main Menu -> Advanced Settings -> System Settings and select Keypad Lock. To lock the IR remote, go to Main Menu -> Advanced Settings -> System Settings and select IR Remote Lock.

## Unlocking the Keypad and IR Remote

To unlock the keypad, press the following keys on the keypad in the order listed: UP, UP, RIGHT, LEFT, DOWN. If the IR remote is unlocked, you can also unlock the keypad by using the IR remote to go to Main Menu -> Advanced Settings -> System Settings and uncheck Keypad Lock.

To unlock the IR remote, press the following keys on the IR remote in the order listed: UP, UP, RIGHT, LEFT, DOWN. If the keypad is unlocked, you can also unlock the IR remote by using the keypad to go to Main Menu -> Advanced Settings -> System Settings and uncheck IR Remote Lock.

## Changing the IR Remote Code Set

The IR remote code set transmitted by the remote and accepted by the display can be configured. This is useful if there are multiple Planar displays and you would like each remote to work only with one of the displays. It can also be used if IR interference with another device, such as a DVD player, is occurring.

To change the IR code on the remote, use the following procedure:

- 1 Press and hold the CODE button on the remote control until the LED on the remote lights solid red (approximately five seconds).
- 2 Enter a new five-digit code between 00000 and 65535. Include leading zeros for codes with four or fewer digits; for example, enter 255 as 00255.
- 3 The LED turns off to confirm the code change. If you enter an invalid code, the LED flashes for three or four seconds. Try again, entering a valid code.

**Note:** The code must match the IR Remote ID Code setting. See page 43.

## Turning the Display On

- 1 Insert the power cord into the display and into the power outlet.
- 2 Ensure the AC switch is set to “—”.
- 3 Press the ON button on the remote or the power button on the keypad.

## Turning the Display Off

With the power on, press the OFF button on the remote or the power button on the keypad to put the LCD panel in a standby mode. To turn off power completely, turn the AC switch to “O” or disconnect the AC power cord from the power outlet.

**Note:** The display may automatically turn off the backlight or enter standby mode if no signal is present for a certain period of time. See the description of the Power Saving Mode setting on page 31 for more information.

## Adjusting the Volume

- 1 Using the remote, press the VOL + or VOL - to increase or decrease the volume. You can also use the Up and Right keys to increase the volume, and the Down and Left keys to decrease the volume.
- 2 Press the MUTE button to temporarily turn off all sound. To restore the sound, press the MUTE button again.

**Note:** The analog audio out is variable. S/PDIF is fixed.

## Selecting Layouts and Input Sources

With Planar QE Series, you can show one source at a time or multiple sources simultaneously. Multiple layout options are available and can be selected from the Inputs and Views Menu (see page 23). Once a layout has been designated, you can assign sources to each of the zones in the layout. The selection of sources must be made one at a time by assigning a current zone. To select the current zone, you can navigate through the on-screen menu (see page 23). Alternatively, you can use the remote or keypad as described next.

### Remote

Press the Zone 1, Zone 2, Zone 3, or Zone 4 buttons on the remote. After selecting the desired zone, you can press the source button (DP, HDMI 1, HDMI 2, HDMI 3, HDMI 4, or OPS). This action will also select the active audio source.

For example, to change Zone 3 to HDMI 3, press the Zone 3 button and then press the HDMI 3 button.

**Note:** The OPS source button will select the ContentSmart source.

### Keypad

Press the SRC button. The input source will be toggled in the following order: HDMI 1, HDMI 2, HDMI 3, HDMI 4, DP, ContentSmart.

**Note:** Sources will toggle through the current zone, or last zone to be modified. Current zones can only be re-assigned in the on-screen menu.

## Navigating Through the Menu

- 1 With the power on, press MENU. The MAIN menu appears.

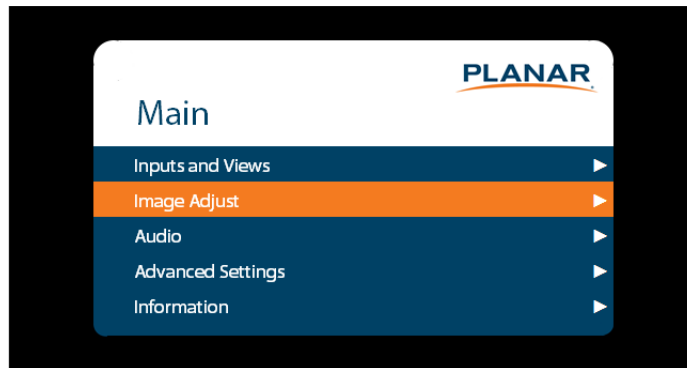

- 2 Within the menu, use ▲, ▼, ◀, ▶ and ENTER to navigate through the menus and adjust options.
- 3 Press PREV on the remote control, or MENU on the keypad, to return to the previous menu. To exit the menu system, press MENU on the remote control, or continue to press MENU on the keypad until the main menu is reached.

## Inputs and Views Menu

This menu shows how the sources will be laid out on the screen based on the current Multi-Source View and Advanced Layouts selections.

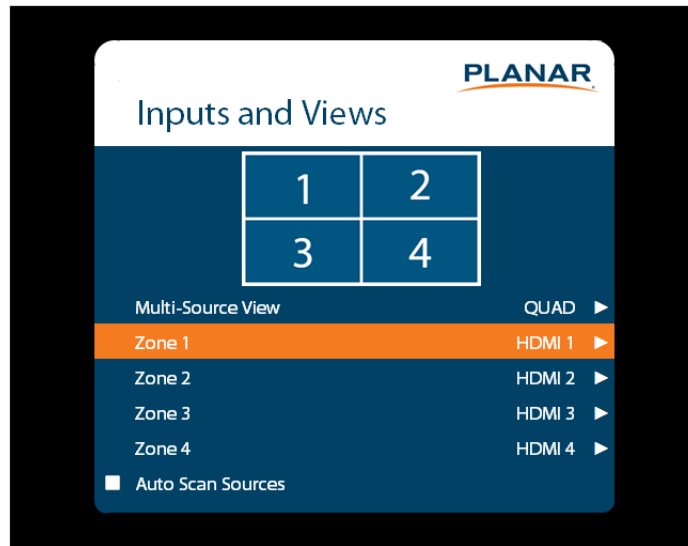

### Multi-Source View

Select the Multi-Source View mode

**Options:** Single, Quad; **Default:** Single

**Note:** You can only use 4K/60Hz in Single mode.

### Zone 1

Select the source displayed in Zone 1

**Options:** HDMI 1, HDMI 2, HDMI 3, HDMI 4, DP, ContentSmart; **Default:** HDMI 1

**Note:** If HDMI1 was selected as another source, ContentSmart cannot be selected. If ContentSmart was selected as another source, HDMI1 cannot be selected.

### Zone 2

Select the source displayed in Zone 2

**Options:** HDMI 1, HDMI 2, HDMI 3, HDMI 4, DP, ContentSmart; **Default:** HDMI 2

**Note:** If HDMI1 was selected as another source, ContentSmart cannot be selected. If ContentSmart was selected as another source, HDMI1 cannot be selected.

### Zone 3

Select the source displayed in Zone 3

**Options:** HDMI 1, HDMI 2, HDMI 3, HDMI 4, DP, ContentSmart; **Default:** HDMI 3

**Note:** If HDMI1 was selected as another source, ContentSmart cannot be selected. If ContentSmart was selected as another source, HDMI1 cannot be selected.

### Zone 4

Select the source displayed in Zone 4

**Options:** HDMI 1, HDMI 2, HDMI 3, HDMI 4, DP, ContentSmart; **Default:** HDMI 4

**Note:** If HDMI1 was selected as another source, ContentSmart cannot be selected. If ContentSmart was selected as another source, HDMI1 cannot be selected.

### Auto Scan Sources

Select whether the display will automatically scan for a valid source on any zone that currently does not have a source

**Options:** On, Off; **Default:** Off

## Image Adjust Menu

This menu is used for making common image adjustments for the current zone.

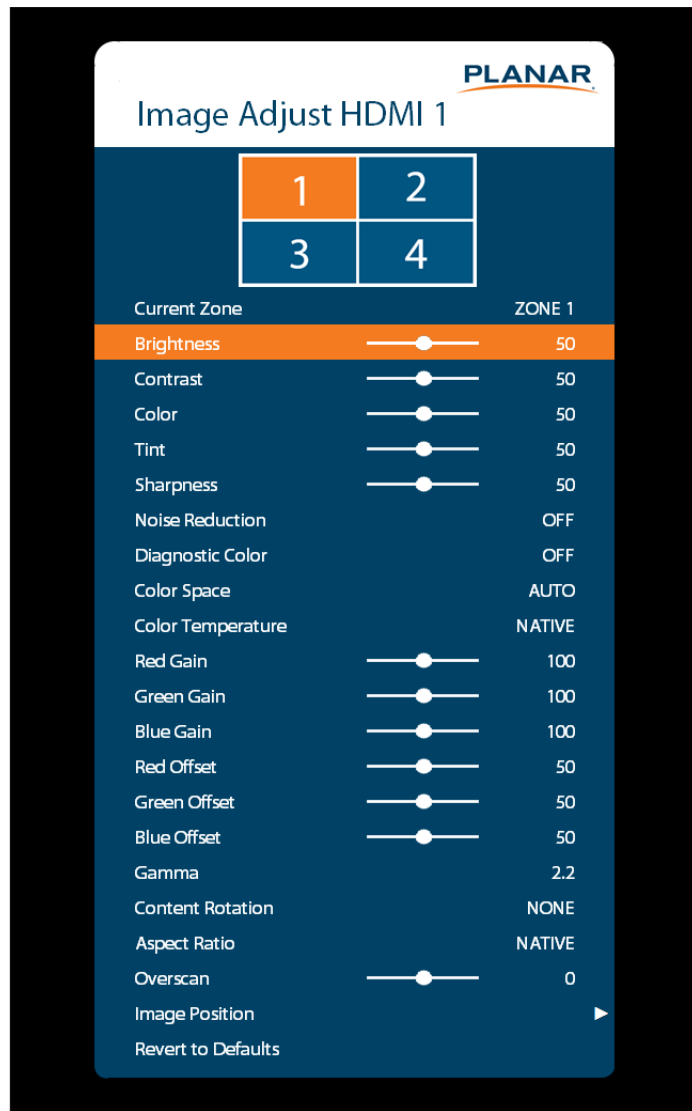

### Current Zone

The zone that is currently being adjusted. All of the settings in this menu are saved per input. The zone's corresponding input source is shown in the title bar, and the graphic beneath that shows which zone is being adjusted in the current Multi-Source View mode and Advanced Layout setting (if applicable).

The current zone can be changed via the menu or by using the ZONE 1-4 keys on the remote control.

**Note:** Changing the Current Zone setting via the ZONE 1-4 keys also changes the Audio Select setting.

## Brightness

Adjust the brightness value of the image  
**Range:** 0~100; **Default:** 50

## Contrast

Adjust the contrast of the image  
**Range:** 0~100; **Default:** 50

## Color

Adjust the saturation of the image  
**Range:** 0~100; **Default:** 50

## Tint

Adjust the hue of the image  
**Range:** 0~100; **Default:** 50

## Sharpness

Adjust the sharpness of the image. Higher numbers are sharper  
**Range:** 0~10; **Default:** 5

## Noise Reduction

Turn on noise reduction processing  
**Options:** Off, Low, Medium, High; **Default:** Off

## Diagnostic Color

Set the image to monochrome. This setting is for use in adjustments to a test pattern and is not stored.  
**Options:** Off, Red, Green, Blue; **Default:** Off

## Color Space

Set the color space of the image  
**Options:** REC601, REC709, RGB, RGB Video, Auto; **Default:** Auto

## Color Temperature

Set the color temperature of the image  
**Options:** 3200K, 5500K, 6500K, 7500K, 9300K, Native; **Default:** Native

## Red Gain

Adjust the red gain of the image  
**Range:** 0~200; **Default:** 100

## Green Gain

Adjust the green gain of the image  
**Range:** 0~200; **Default:** 100



**Blue Gain**

Adjust the blue gain of the image  
**Range:** 0~200; **Default:** 100

**Red Offset**

Adjust the red offset of the image  
**Range:** 0~100; **Default:** 50

**Green Offset**

Adjust the green offset of the image  
**Range:** 0~100; **Default:** 50

**Blue Offset**

Adjust the blue offset of the image  
**Range:** 0~100; **Default:** 50

**Gamma**

Set the gamma of the image  
**Options:** 1.5, 1.55, 1.6, 1.65, 1.7, 1.75, 1.8, 1.85, 1.9, 1.95, 2.0, 2.05, 2.1, 2.15, 2.2, 2.25, 2.3, 2.35, 2.4, 2.45, 2.5, 2.55, 2.6, 2.65, 2.7, 2.75, 2.8  
**Default:** 2.2

**Content Rotation**

Rotate the image on the display  
**Options:** None, 90, 180, 270; **Default:** None

**Aspect Ratio**

Set how the source is treated when the aspect ratio of the input is different than the aspect ratio of the zone it is in. If the image does not fill the zone completely, the extra margins are black.  
**Options:** Auto, 16:9, 4:3, Fill Screen, Native, Letterbox; **Default:** Auto

**Overscan**

Set the percentage of the image to remove from each edge  
**Range:** 0~20; **Default:** 0

**Image Position**

Move the image horizontally or vertically. The amount to move is measured in input pixels.  
**Range:** -1000~1000; **Default:** 0

**Revert to Defaults**

Reset all settings in the Image Adjust menu to their factory defaults for the current zone only

## Audio Menu

This menu enables you to make audio adjustments to the selected zone.

**Note:** Volume, Bass, Treble and Balance do not apply to the S/PDIF output.



### Audio Select

The zone that is currently being adjusted and whose audio is being played. The zone's corresponding input source is shown in the title bar.

**Options:** Zone 1, Zone 2, Zone 3, Zone 4; **Default:** Zone 1

**Note:** Changing the Audio Select setting via the ZONE 1-4 keys also changes the Current Zone setting.

### Volume

Set the volume of the audio

**Range:** 0~100; **Default:** 50

### Bass

Set the bass level

**Range:** 0~100; **Default:** 50

**Note:** This setting applies only to the internal speakers, and cannot be adjusted for the Line Out connector.

### Treble

Set the treble level

**Range:** 0~100; **Default:** 50

**Note:** This setting applies only to the internal speakers, and cannot be adjusted for the Line Out connector.

**Balance**

Set the audio balance

**Range:** 0~100; **Default:** 50

**Enable Internal  
Speakers**

Disable or enable the built-in speakers

**Options:** On, Off; **Default:** On

**Mute**

Mute or unmute the audio

**Options:** On or Off; **Default:** Off

## Advanced Settings Menu

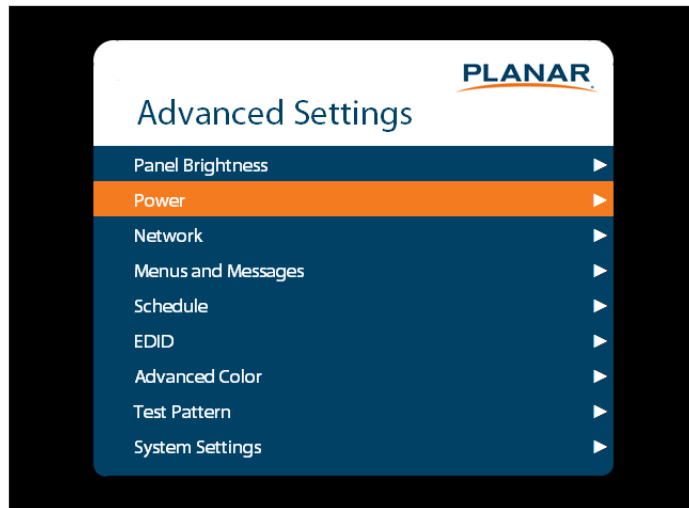

### Panel Brightness Submenu



#### Intensity

Set the intensity of the LCD backlight  
**Range:** 0~100; **Default:** 75

#### Local Dimming

Turn on or off the local dimming function, if supported by the display  
**Options:** On, Off; **Default:** On

## Power Submenu

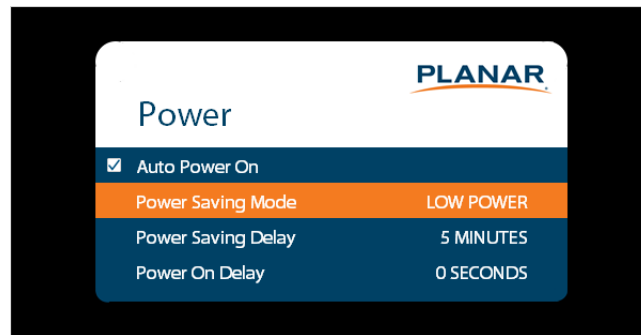
**Auto Power On**

Set whether the system will automatically leave standby mode after AC power is applied  
**Options:** On, Off; **Default:** Off

**Power Saving Mode**

Set the action to take if there is no signal detected after the period of time selected by the Power Saving Delay setting:

- **Disabled:** The display will remain on even if no signal is present.
- **Low Power:** The display will enter standby mode if no signal is detected after the specified period of time.
- **Wake on Signal:** The display will enter a reduced power mode if no signal is detected after the specified period of time. When in this state, the display will turn on when a signal is detected or when any key is pressed on the keypad or IR remote.

**Default:** Low Power

**Power Saving Delay**

Set the number of minutes to delay before initiating the power saving mode action (if any)

**Options:** 1 Minute, 5 Minutes, 15 Minutes, 30 Minutes, 60 Minutes; **Default:** 5 minutes

**Power On Delay**

Select the amount of time to delay before turning on the display. Depending on the electrical capabilities at the installation site, it can be necessary to adjust the power on sequence of the displays if there are multiple displays in the installation. Use this control to ensure that each display will power on at a different time, avoiding such problems.

**Options:** 0-10 seconds, in 0.1 second increments; **Default:** 0 seconds

## Network Submenu

The default static IP values are:

- IP Address: 192.168.12.12
- Subnet Mask: 255.255.255.0
- Default Gateway: 192.168.12.1

The static IP settings that you program will be used if a DHCP server cannot be found.

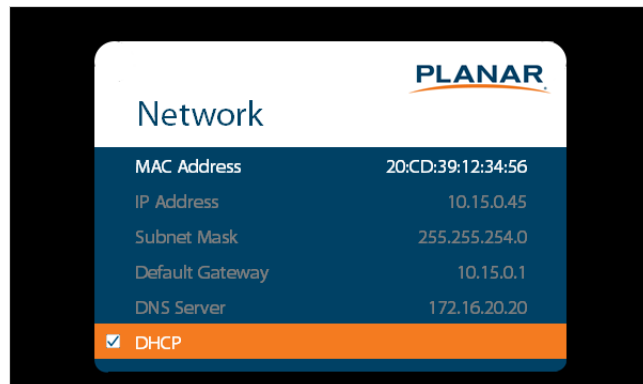

### MAC Address

The MAC address of the system

### IP Address

The current network address. You can use the number keys on the remote to enter this information.

### Subnet Mask

The current subnet mask. You can use the number keys on the remote to enter this information.

### Default Gateway

The current default gateway. You can use the number keys on the remote to enter this information.

### DNS Server

The current DNS server. You can use the number keys on the remote to enter this information.

**Note:** The specified DNS server is used when Use Network Time is checked for the Set Date and Time setting.

### DHCP

Turn DHCP on or off

**Options:** On, Off; **Default:** On

## Menus and Messages Submenu

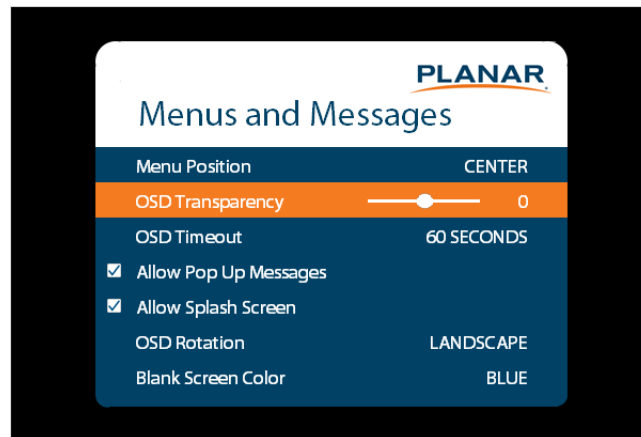

### Menu Position

Move the OSD menu to a different location on the screen

**Options:** Center, Upper Left, Upper Right, Lower Left, Lower Right; **Default:** Center

### OSD Transparency

Set the transparency of the OSD so that the image behind it can be seen. Higher values mean greater transparency.

**Range:** 0~5; **Default:** 0

### OSD Timeout

Set the amount of time in seconds since the last keypress before the OSD menu automatically closes. If set to Off, the menu never automatically closes.

**Options:** Off, 10 Seconds, 30 Seconds, 60 Seconds, 120 Seconds, 240 Seconds; **Default:** 60 Seconds

### Allow Pop Up Messages

Suppress messages that pop up automatically. When set to No, the source status message and the volume slider bar will not be displayed.

**Options:** Yes or No; **Default:** Yes

### Allow Splash Screen

Enable or disable the splash screen during startup

**Options:** Enable or Disable; **Default:** Enable

### OSD Rotation

Rotate the OSD menu so that it is readable if the display is mounted in portrait orientation

**Options:** Landscape or Portrait; **Default:** Landscape

## Blank Screen Color

Select the color to display when there is no signal in a zone

**Options:** Black, White, Gray, Red, Green, Blue, Cyan, Magenta, Yellow

**Default:** Black

## Schedule Submenu

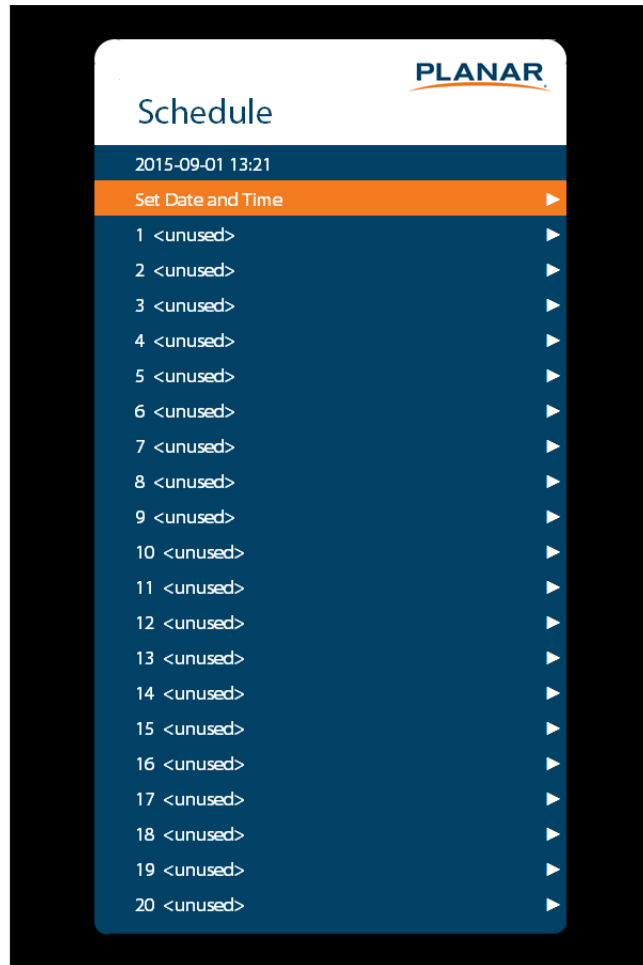



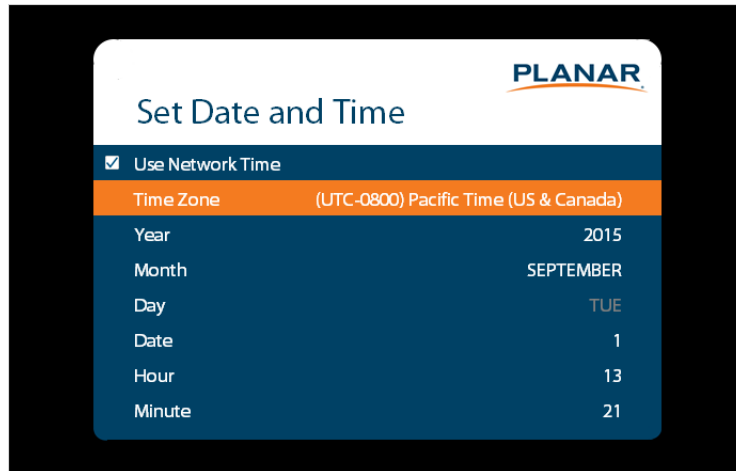

## Set Date and Time

Set the internal system clock. If **Use Network Time** is unchecked, you can set the following settings individually: Time Zone, Year, Month, Day, Date, Hour, and Minute.

**Note:** If Use Network Time is checked and DHCP is unchecked, the display will be unable to obtain the network time unless a DNS server is programmed. This is done via the DNS Server setting in the Network menu or the serial command interface.



## Set Event 1~Event 20

**Event Enabled:** Turns on the event. If disabled, the settings are saved so that the event can be re-enabled.

**Frequency:** The frequency of the event. Options are Daily, Weekly, Weekdays, Weekends.

**Action:** The action to take for the event. Options are Turn On, Turn Off, Panel Brightness.

**Data:** The backlight setting when the Action is set to Panel Brightness.

## EDID Submenu

This menu specifies the EDID format and preferred timing for the selected connector.

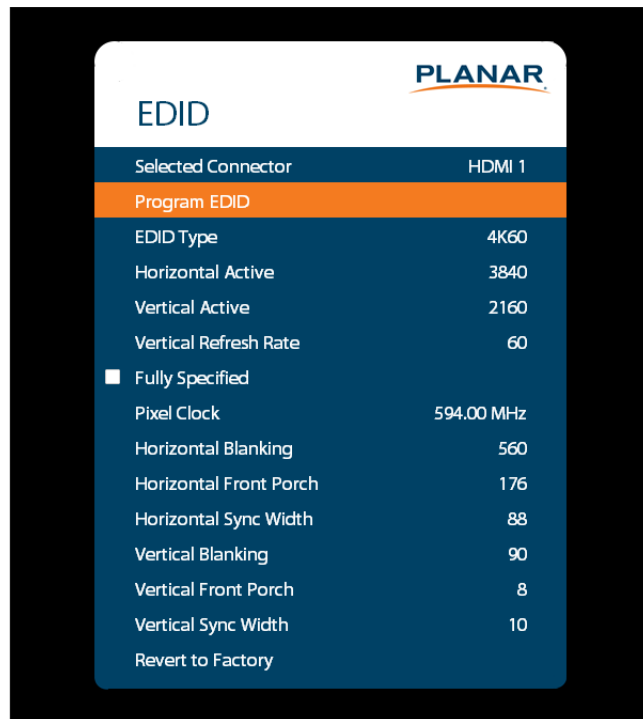

### Selected Connector

Set which connector is used

**Options:** HDMI 1, HDMI 2, HDMI 3, HDMI 4, DP, ContentSmart, All

### Program EDID

Program the EDID information for the selected connector based on the selections in the EDID submenu

### EDID Type

Set the EDID type to determine the base EDID used for the current connector:

- 4K60 selects an EDID format compliant with HDMI 2.0 and DP 1.2
- 4K30 selects an EDID format compliant with HDMI 1.4b and DP 1.1
- 1080P selects an EDID format compliant with HDMI 1.3 and DP 1.1

**Options:** 4K60, 4K30, 1080P

### Horizontal Active

The number of active pixels in a line

**Range:** 0~4095

**Vertical Active**

The number of active lines in a field  
**Range:** 0~4095

**Vertical Refresh Rate**

The number of fields per second rounded to the nearest Hz  
**Range:** 0~120

**Fully Specified**

Determine how the final detailed timing is calculated. If disabled, it is calculated based on Horizontal Active, Vertical Active, and Vertical Refresh Rate values. If enabled, it is calculated based on all of the EDID values except for Vertical Refresh Rate.

**Options:** Disabled, Enabled

**Note:** This setting should only be enabled by advanced users.

**Pixel Clock**

The value of the pixel clock, in megahertz  
**Range:** 0~600.00, in 0.01 increments

**Horizontal Blanking**

The number of non-active pixel clocks in a line  
**Range:** 0~1023

**Horizontal Front Porch**

The number of pixel clocks in the horizontal front porch  
**Range:** 0~1023

**Horizontal Sync Width**

The number of pixel clocks in the horizontal sync pulse  
**Range:** 0~255

**Vertical Blanking**

The number of non-active lines in a field  
**Range:** 0~255

**Vertical Front Porch**

The number of line times in the vertical front porch  
**Range:** 0~255

**Vertical Sync Width**

The number of line times in the vertical sync  
**Range:** 0~255

## Revert to Factory

Reset the EDID type and timings to the default values for the selected connector

### Advanced Color Submenu

This menu adjusts the color coordinates of the current zone. These controls are used by advanced installers to achieve exact color point targets on the display. In some cases, the target color coordinates may not be achievable. In this case, an asterisk (\*) will appear next to the color coordinate value.

**Note:** The white color point should be adjusted before adjusting the other color points.

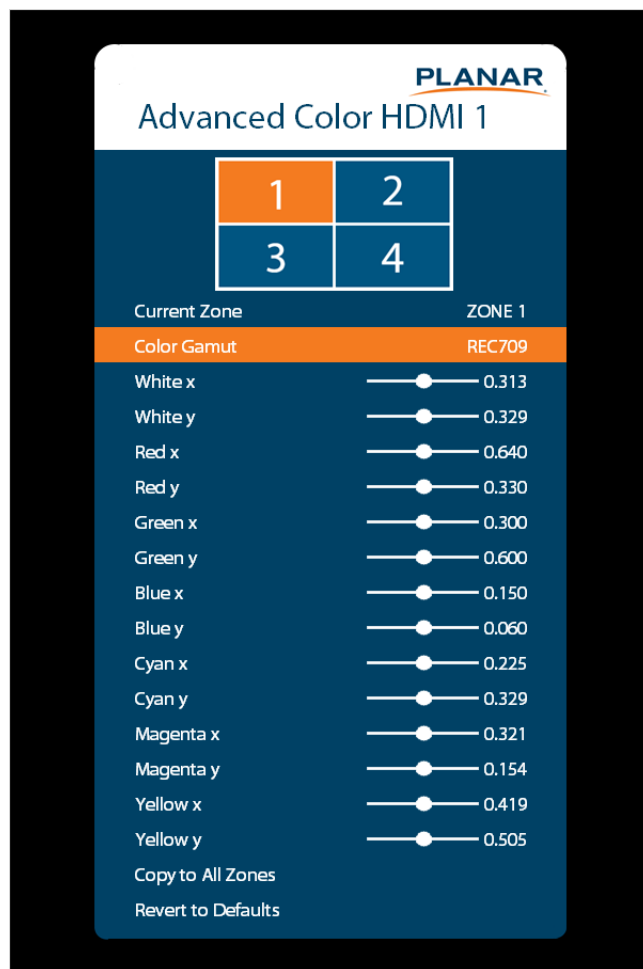

## Current Zone

The zone that is currently being adjusted. All of the settings in this menu are saved per zone, and all color coordinate values are also saved per Color Gamut setting. The zone's corresponding input source is shown in the title bar, and the graphic beneath that shows which zone is being adjusted in the current Multi-Source View mode and Advanced Layout setting (if applicable).

The current zone can be changed via the menu or by using the ZONE 1-4 keys on the remote control.

**Note:** Changing the Current Zone setting via the ZONE 1-4 keys also changes the Audio Select setting.

## White x

Adjust the x coordinate of the white color point  
**Range:** 0.000-0.800

## White y

Adjust the y coordinate of the white color point  
**Range:** 0.000-0.800

## Red x

Adjust the x coordinate of the red color point  
**Range:** 0.000-0.800

## Red y

Adjust the y coordinate of the red color point  
**Range:** 0.000-0.800

## Green x

Adjust the x coordinate of the green color point  
**Range:** 0.000-0.800

## Green y

Adjust the y coordinate of the green color point  
**Range:** 0.000-0.800

## Blue x

Adjust the x coordinate of the blue color point  
**Range:** 0.000-0.800

## Blue y

Adjust the y coordinate of the blue color point  
**Range:** 0.000-0.800

**Cyan x**

Adjust the x coordinate of the cyan color point  
**Range:** 0.000-0.800

**Cyan y**

Adjust the y coordinate of the cyan color point  
**Range:** 0.000-0.800

**Magenta x**

Adjust the x coordinate of the magenta color point  
**Range:** 0.000-0.800

**Magenta y**

Adjust the y coordinate of the magenta color point  
**Range:** 0.000-0.800

**Yellow x**

Adjust the x coordinate of the yellow color point  
**Range:** 0.000-0.800

**Yellow y**

Adjust the y coordinate of the yellow color point  
**Range:** 0.000-0.800

**Copy to All Zones**

Copy the color coordinate settings for the current zone and the current Color Gamut setting to all other zones

**Revert to Defaults**

Reset the color coordinate settings for the current zone and the current Color Gamut setting to their default values

## Test Patterns Submenu

This menu selects a test pattern to show on the display for diagnostic purposes.

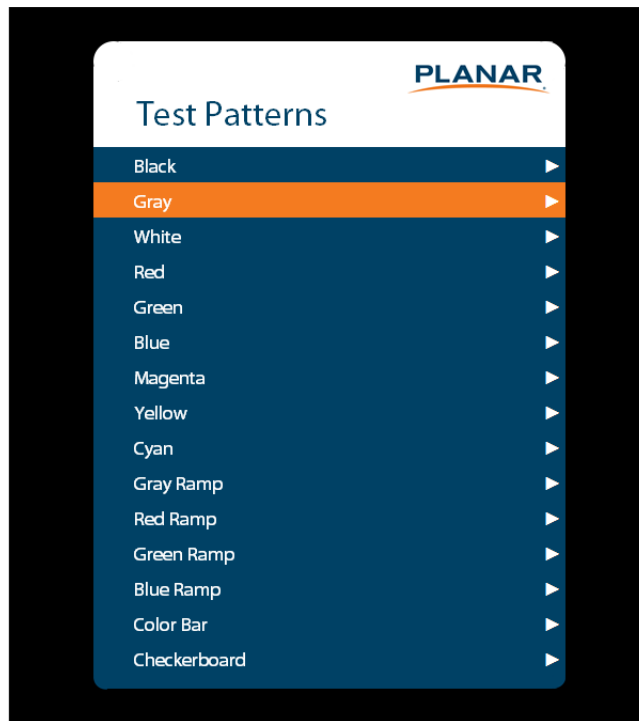

### Test Patterns

**Options:** Black, Gray, White, Red, Green, Blue, Magenta, Yellow, Cyan, Gray Ramp, Red Ramp, Blue Ramp, Color Bar, Checkerboard

## System Settings Submenu

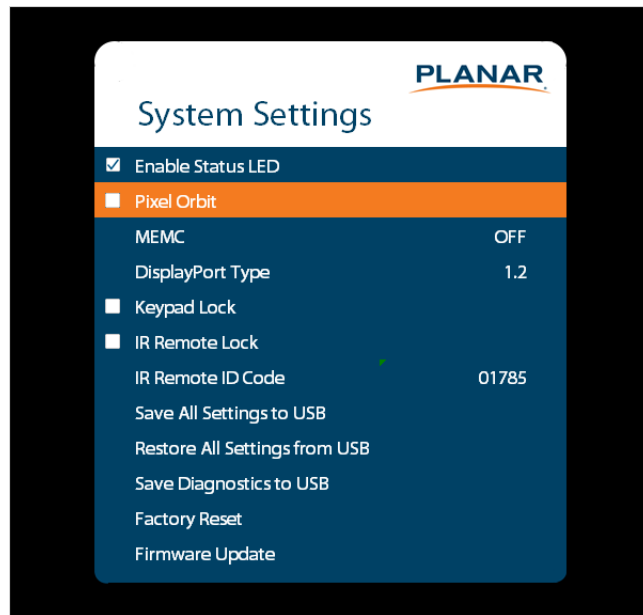
**Enable Status LED**

When enabled, the status LEDs on the back of the display behave as indicated on page 15. When disabled, the status LEDs are always turned off.

**Options:** Disable, Enable; **Default:** Enable

**Pixel Orbit**

Create slight frame motion to help avoid image retention

**Options:** Enable, Disable; **Default:** Disable

**MEMC**

Enable motion estimation motion compensation (frame interpolation). This improves smoothness for fast motion video content.

**Options:** Off, Low, Medium, High; **Default:** Off

**DisplayPort Type**

Set the version of DisplayPort that is used by the system

**Options:** 1.1, 1.2; **Default:** 1.2

**Keypad Lock**

Lock or unlock the keypad. When it is enabled, all keypad presses will be ignored.

**Options:** Enable, Disable; **Default:** Disable

**IR Remote Lock**

Lock or unlock the remote control. When it is enabled, all remote control presses will be ignored.

**Options:** Enable, Disable; **Default:** Disable



### IR Remote ID Code

Selects the IR remote code set accepted by the display

**Options:** 00000-65535; **Default:** 01785

### Save All Settings to USB

Save all settings in the display to a USB flash drive. The saved file will be named *Planar-settings.bin* and will be saved in the root folder of the USB flash drive.

**Note:** A USB flash drive must be inserted into the USB-A connector prior to using this feature. The USB flash drive must be formatted as FAT32. This feature will not work with the NTFS file system.

### Restore All Settings from USB

Restores all settings in the display from a USB flash drive. The settings file must be named *Planar-settings.bin* and must be located in the root folder of the USB flash drive.

**Note:** A USB flash drive must be inserted into the USB-A connector prior to using this feature. The USB flash drive must be formatted as FAT32. This feature will not work with the NTFS file system.

### Save Diagnostics to USB

Save a diagnostic report to a USB flash drive to help Planar Technical Support troubleshoot any issues. The saved file will be named *Planar-diagnostics.bin* and will be saved in the root folder of the USB flash drive.

**Note:** A USB flash drive must be inserted into the USB-A connector prior to using this feature. The USB flash drive must be formatted as FAT32. This feature will not work with the NTFS file system.

### Factory Reset

Return the saved settings in a system to their factory defaults

### Firmware Update

Update the firmware for the display. Refer to the instructions on the firmware release package for more information.

## Information Menu

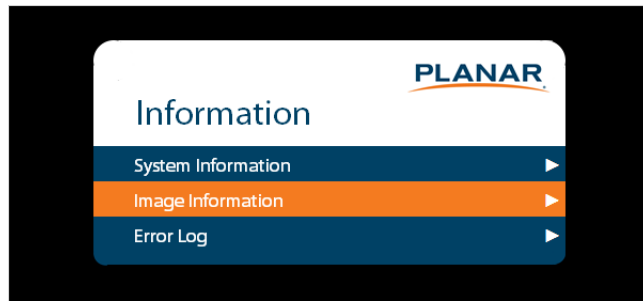

### System Information Submenu

This menu displays version information for all programmable parts in the system. It also contains the model and serial number.

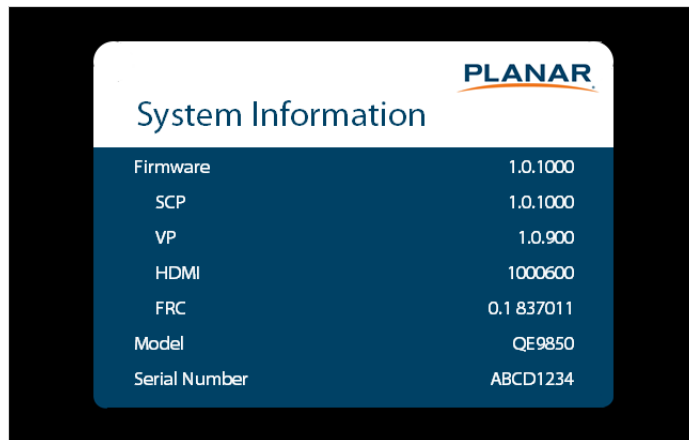

### Image Information Submenu

This menu displays image details for the current zone. If more than one zone is available, you can change zones by setting the **Current Zone** option.

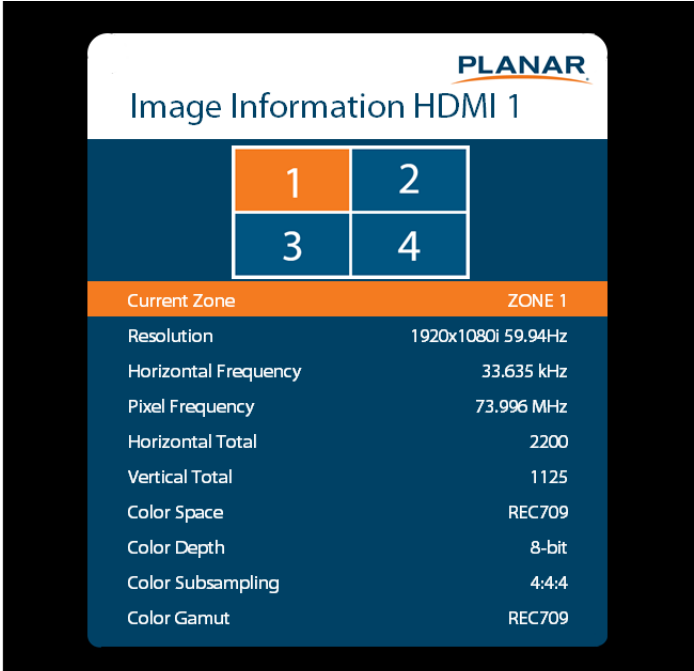

### Error Log Submenu

This menu displays a chronological list of system errors that have occurred. For a list of possible errors, see "Error Codes" on page 100.

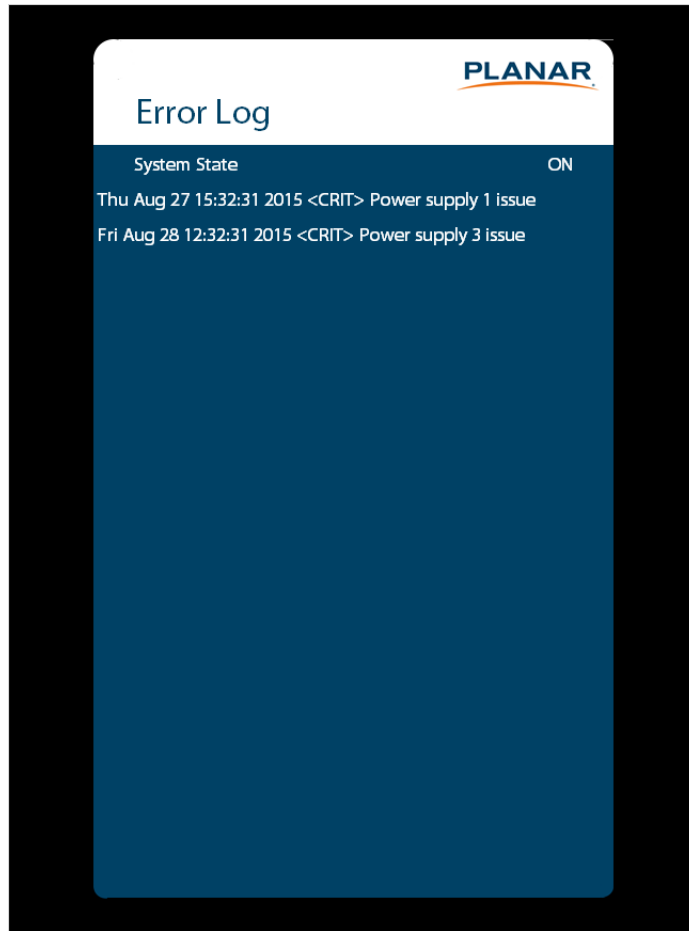

## Using the Touch Screen

You can use the touch screen to control your Windows, Mac or Linux operating system. The Planar QE Series is HID compliant, delivering up to 20 points of touch on both Windows and Linux without a driver. Single touch only is supported for Mac operating systems. To achieve more than single touch Mac support, drivers will need to be installed, which can be found on <http://www.planar.com/support>.

**Note:** Ensure that you have installed the USB cable on the display to a computer.

# Embedded Planar ContentSmart

## Feature Highlights

The Embedded Planar ContentSmart is a UHD (3840 x 2160) high definition digital signage media player featuring an industrial-grade mechanical design, versatile open-standard HTML5 and SMIL programmability.

- Hardware decoding of MPEG1/2/4, H.264, H.265, and VC-1 media formats
- 8GB on-board flash local storage with microSD expansion slot
- Integrated audio and video output via HDMI 2.0
- 2 USB ports
- Built-in wireless b/g/n network
- Support for HTML5 widgets for dynamic content (W3C Widgets standard)
- Industry leading W3C SMIL support for developers
- Supports full POPAI Screen Media Formats Standards profiles S1 to S12, and E1 to E8
- Multiple 3rd party software solution compatibility
- Support for touch screen functionality

## Loading Content

There are three methods for loading content onto the player:

- Using the Planar ContentSmart Software to load content onto the player's on-board flash memory or a microSD card. Instructions for creating the content can be found in the *Planar ContentSmart Software User Manual*.
- Creating your own HTML5 and SMIL content. See page 54 for information on how to set up the player to retrieve the content from a remote server.
- Enabling the player's EasyPlay feature, allowing photos or videos to be played from a USB flash drive or microSD card. See page 59.

# Configuring the Player

## Basic Settings

A USB mouse must be attached to the player to configure settings.

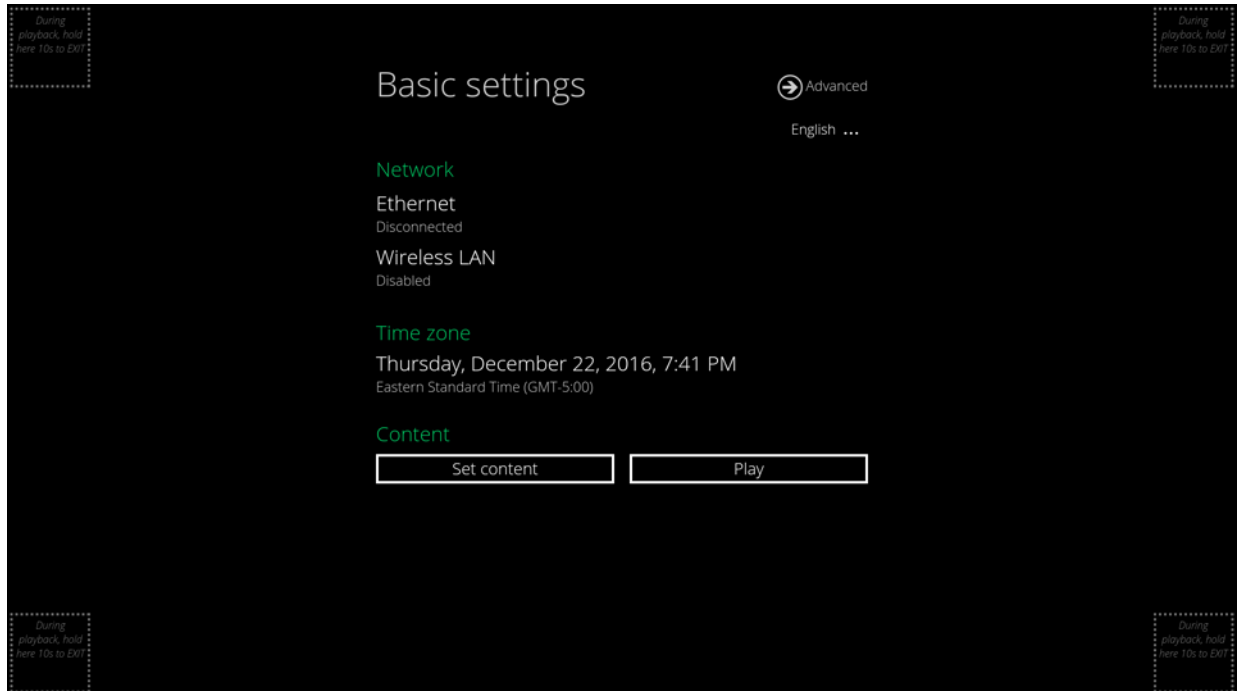

Basic settings include:

- Network
- Time zone
- Content

Each time the Basic settings menu is entered, playback will automatically begin after 15 seconds if content services have been previously set. Auto playback can be canceled by clicking on the button before the countdown ends.

The user is able to enter Advanced Settings by clicking the **Advanced** button.

To enter the menu system at any time during playback, plug in a USB mouse and hold the left mouse key in the corner area as shown below for 10 seconds.



**Note:** The player will ask for a password if a password has been configured.

## Connect the Player to Your Network

### Wired Connection

To use the wired Ethernet connection, connect an Ethernet cable. Ethernet connection takes priority over wireless connection.

#### **DHCP – Automatically assign network IP address**

- 1 Turn on Ethernet by checking the **Use Ethernet** box. If using DHCP, no further action is required.

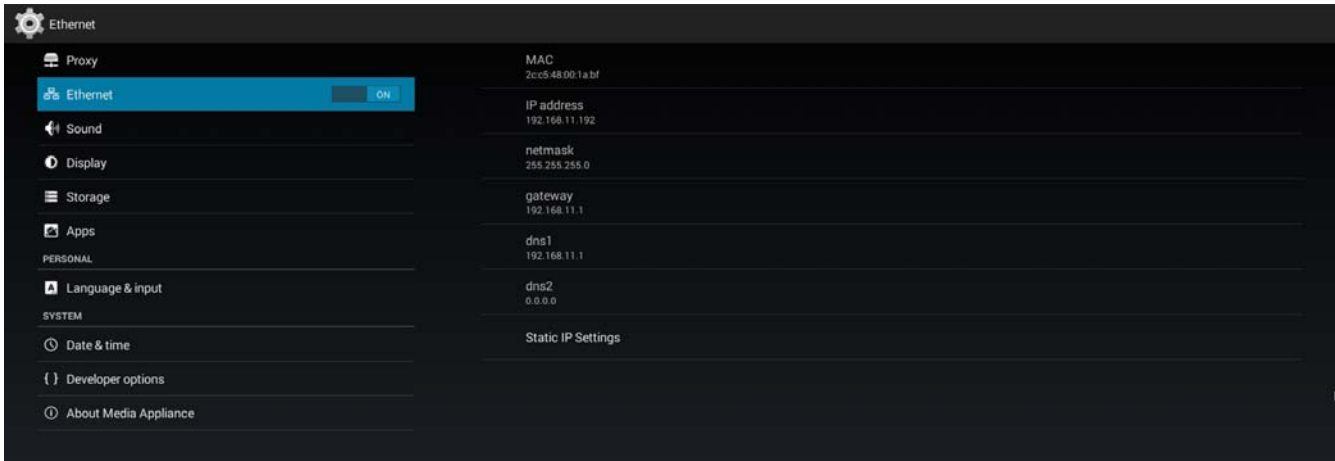

#### **Static IP – Manually assign network IP address**

- 1 Click **Static IP Settings** to configure a static IP address.

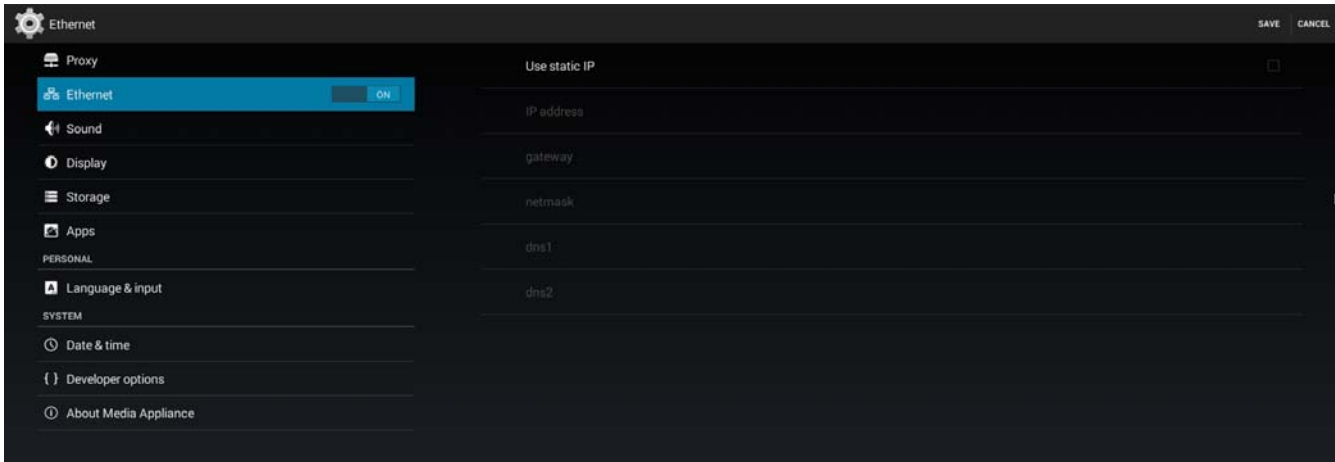



## Proxy Settings

- 1 In Basic settings, click the **Advanced** button. The advanced configuration menu will be launched.

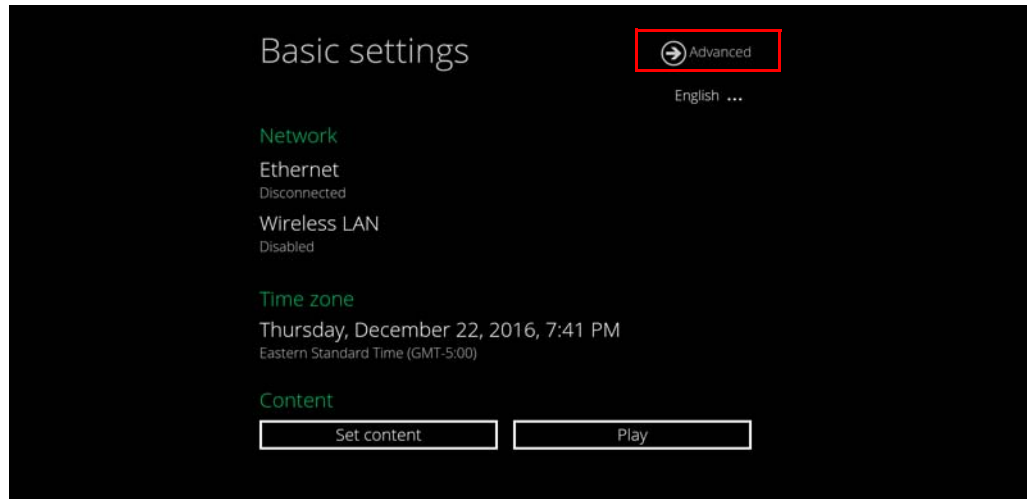

- 2 Click **Network**, and then click **Advanced**.

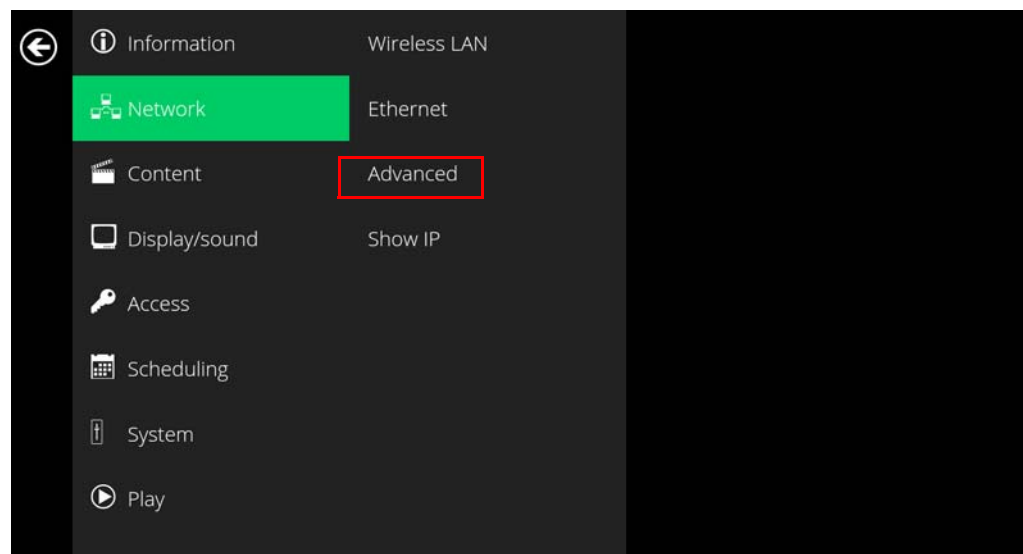

- 3 The Proxy setting menu will be launched. Input the proxy hostname and port, and then click **Done** to finish the configuration.

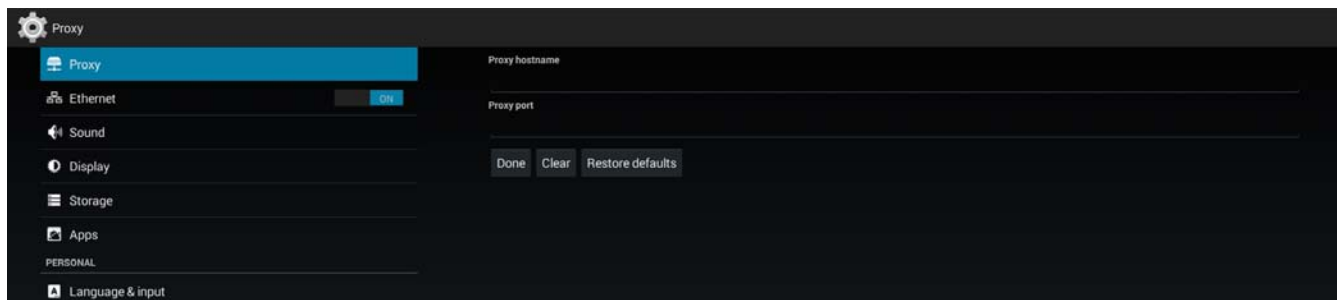

## Show IP Settings

- 1 In Basic settings, click the **Advanced** button. The advanced configuration menu will be launched.
- 2 Click **Network**, and then click **Show IP**.

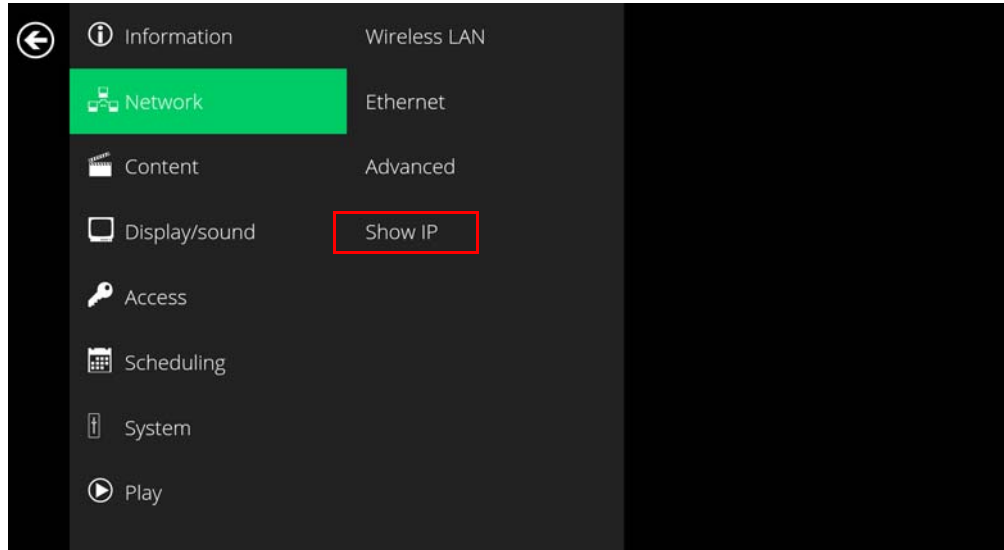

- 3 This feature controls whether the IP address is displayed in the Basic settings menu and is enabled by default. When disabled, the Basic settings will display “connected” instead of the assigned IP address.

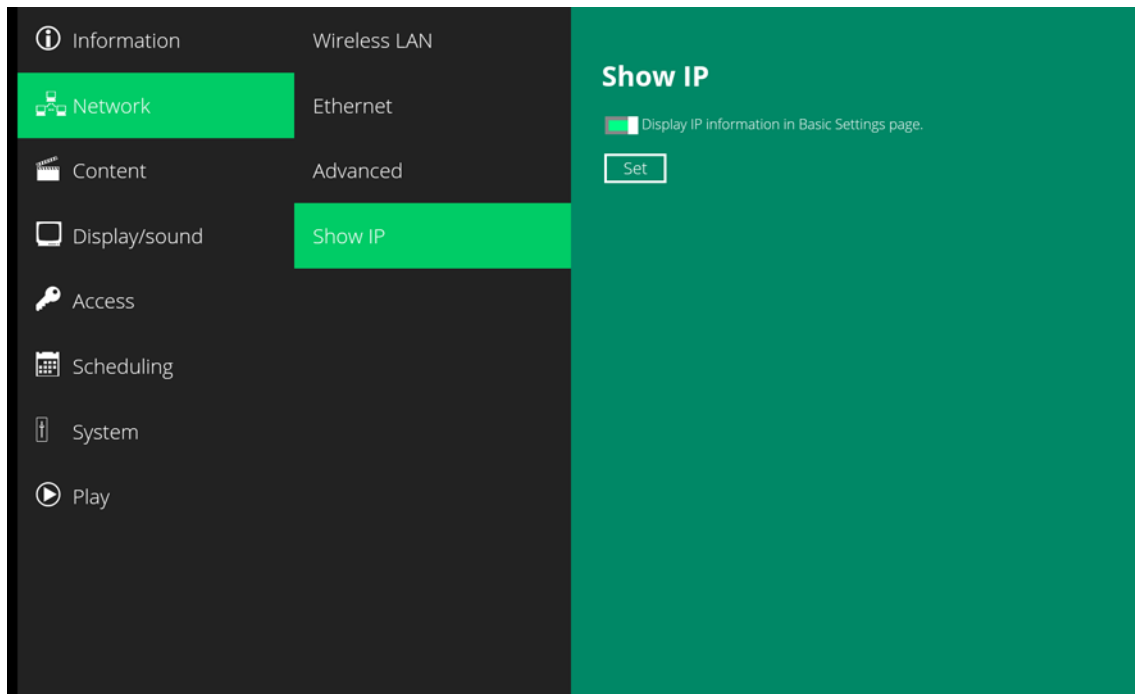

## Time Zone Settings

- 1 In Basic settings, click **Time zone**.

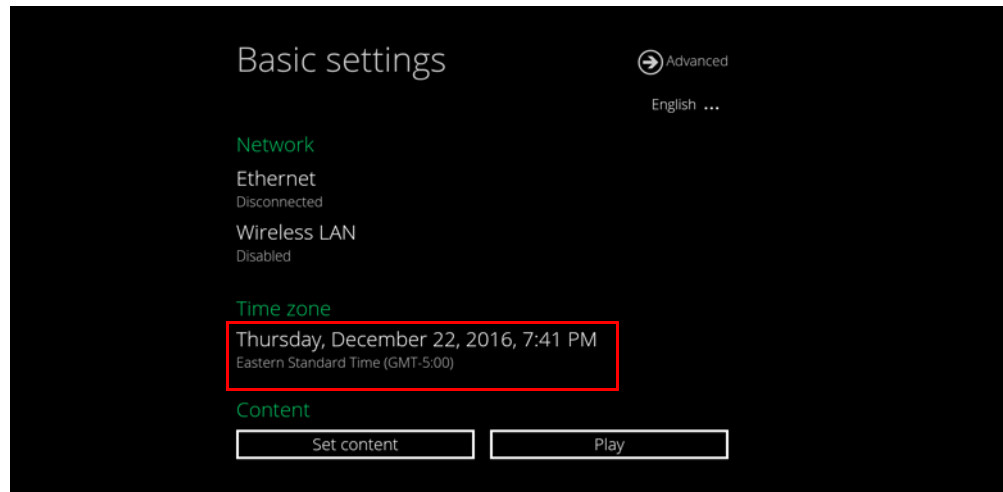

- 2 Choose the correct time zone from the available options.

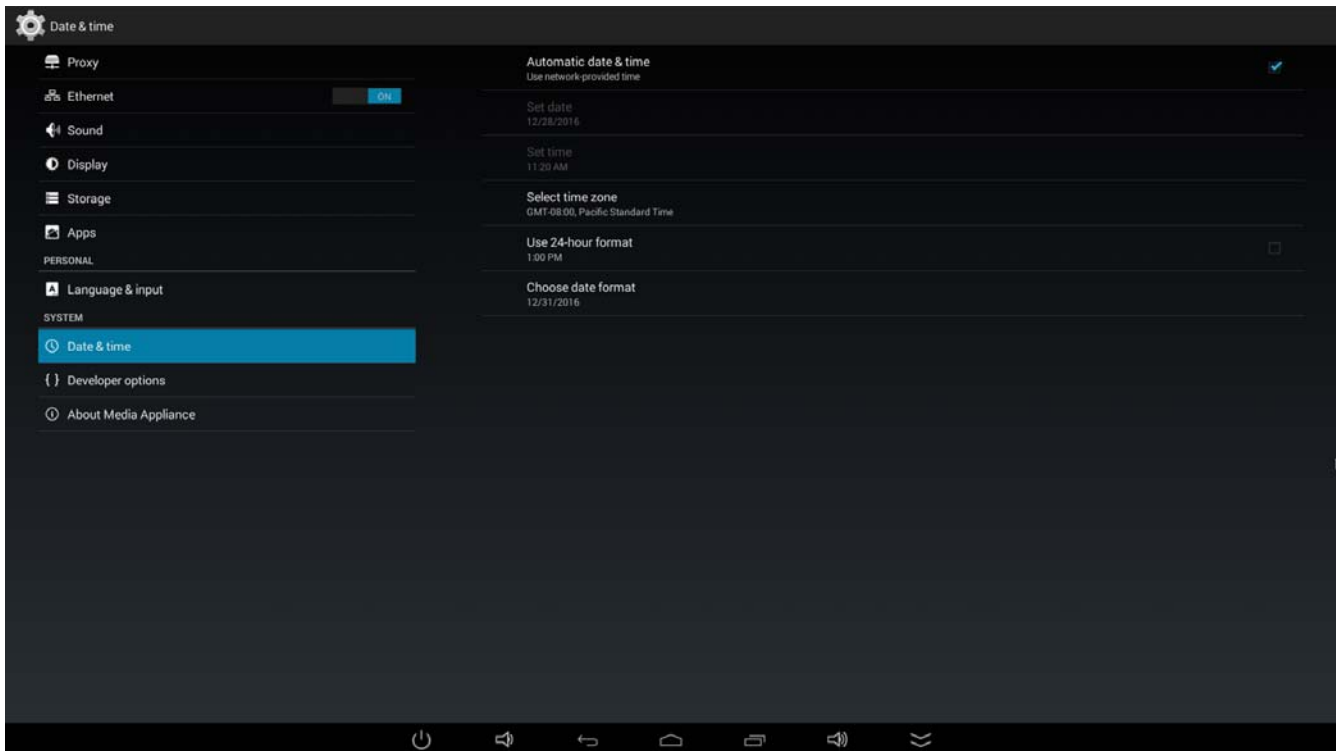

## Content Settings

**Note:** The steps in this section are not necessary if a playlist has been loaded using the ContentSmart software. The proper URL has already been loaded by the ContentSmart software.

- 1 Click the **Set content** button.

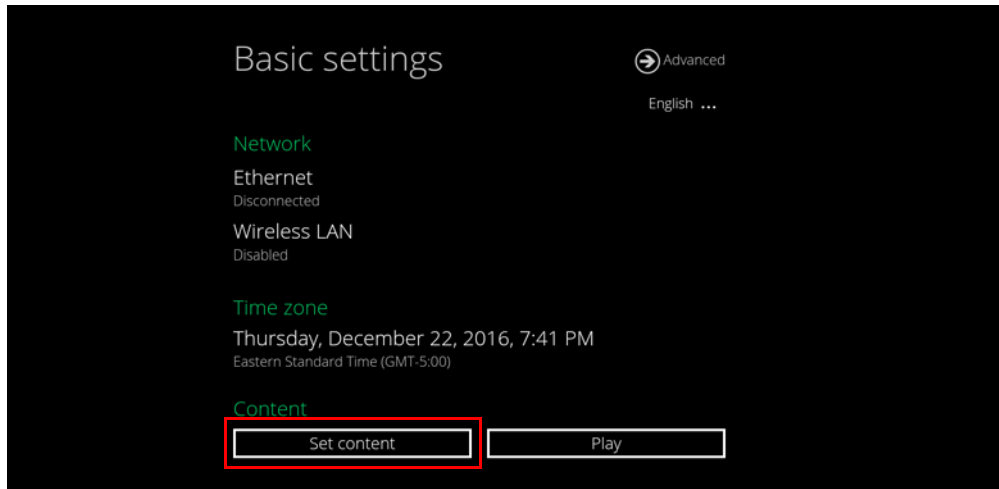

- 2 Input the **SMIL/HTML5 content URL** and click **Set**. It will return to **Basic settings** automatically.



- 3** The player will check the availability of the **SMIL/HTML5 content URL**, with the **Play** button showing **Checking...**

The checking action can be canceled by clicking the **Checking...** button. It will change back to **Play**.

**Note:** It is highly recommended to let the player check the availability of the content URL. Clicking the **Play** button with a bad/invalid URL set will cause the player to reboot if the **FailSafe** function is not configured.

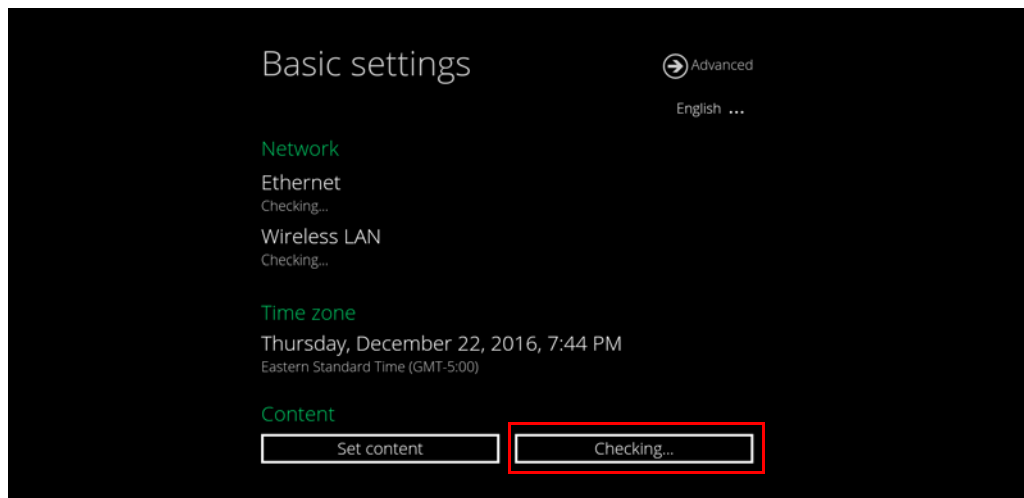

- 4** If the **SMIL/HTML5 content URL** is available, the **Play** button will change to a 15-second countdown and the playback will start after the countdown. The countdown can be canceled by clicking the button.

If it keeps showing **Checking...** for a long time, go back to **Set content** to check the correctness of the URL.

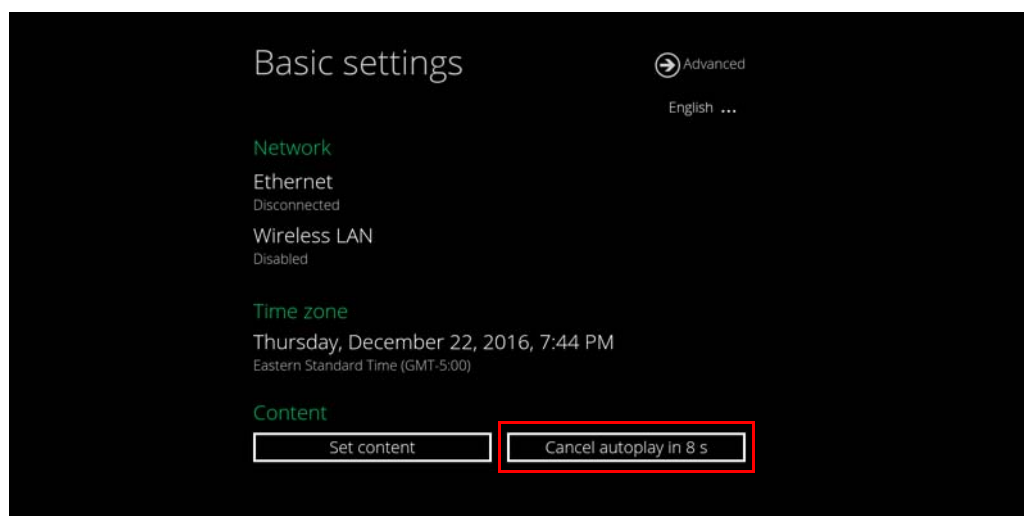

## Player Information

Users can check the player's basic information including the Health status, Firmware version and Player ID.

- 1 Click the **Advanced** button. The advanced configuration menu will be launched.
- 2 Click **Information**. The definitions of the Health Status are:
  - Green – Normal. The device is connected to the URL server.
  - Blue – Local. The device is playing content from the USB drive or SD card.
  - Gray – Disconnected. The device is disconnected.

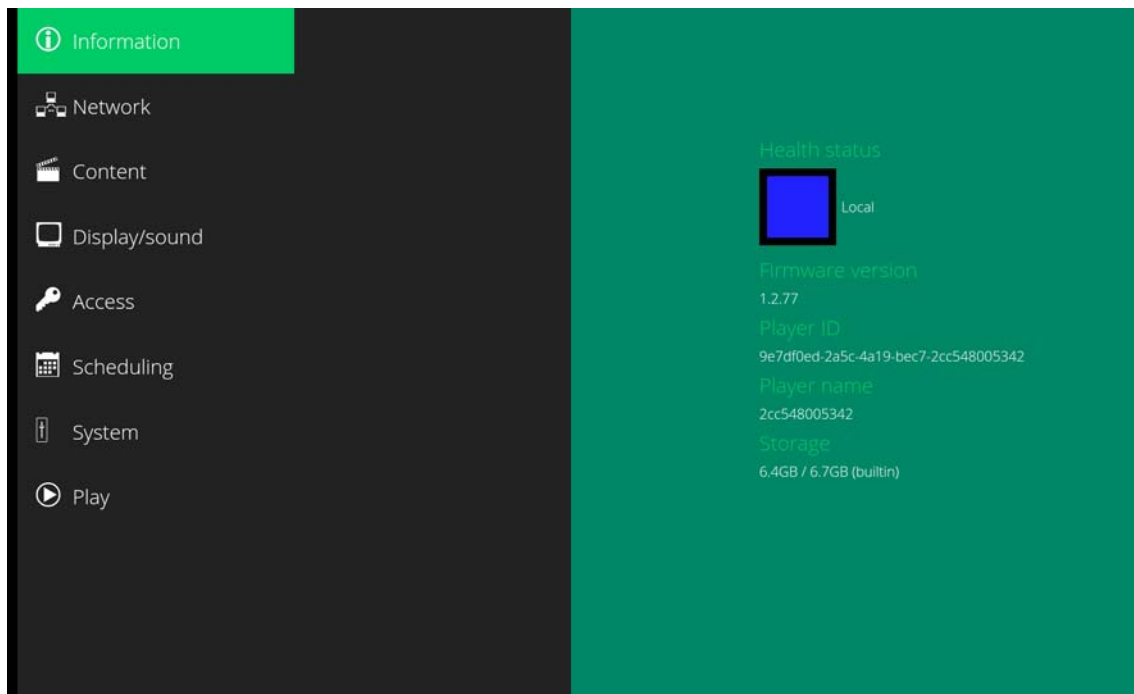

## Content Configuration – AppStart

**Note:** The steps in this section are not necessary if a playlist has been loaded using the ContentSmart software. The proper URL has already been loaded by the ContentSmart software.

Users can assign the URL and APP for execution right after the system starts up.

- 1 Click the **Advanced** button.
- 2 Click **Content**, and then click **AppStart**.
- 3 Enter the valid URL of HTML/SMIL in **AppStart**. If you already configured the SMIL/HTML5 content URL via the **Set content** button, the URL would be shown here.
- 4 The **Advanced** option is used for third-party App configuration only.

The screenshot displays the 'AppStart' configuration screen. On the left, a sidebar lists various system settings, with 'Content' highlighted in green. The main area is titled 'AppStart' and contains several input fields and a 'Set' button. The 'URL' field is highlighted with a red rectangular box and contains the text 'http://'. Below it, an 'Advanced' section is expanded, showing fields for 'Package name' (com.ladea.player), 'Class name' (com.ladea.player.SmilActivity), 'Action' (android.intent.action.VIEW), and 'Type' (empty). A 'Set' button is located at the bottom of the configuration area.

## Content Configuration – FailSafe

Users can assign the URL and APP for execution while the system has failed to play the assigned content.

- 1 Click the **Advanced** button. The advanced configuration menu will be launched.
- 2 Click **Content**, and then click **FailSafe**.
- 3 Enter the URL of HTML/SMIL in FailSafe.
- 4 The Advanced option is used for third-party App configuration only.

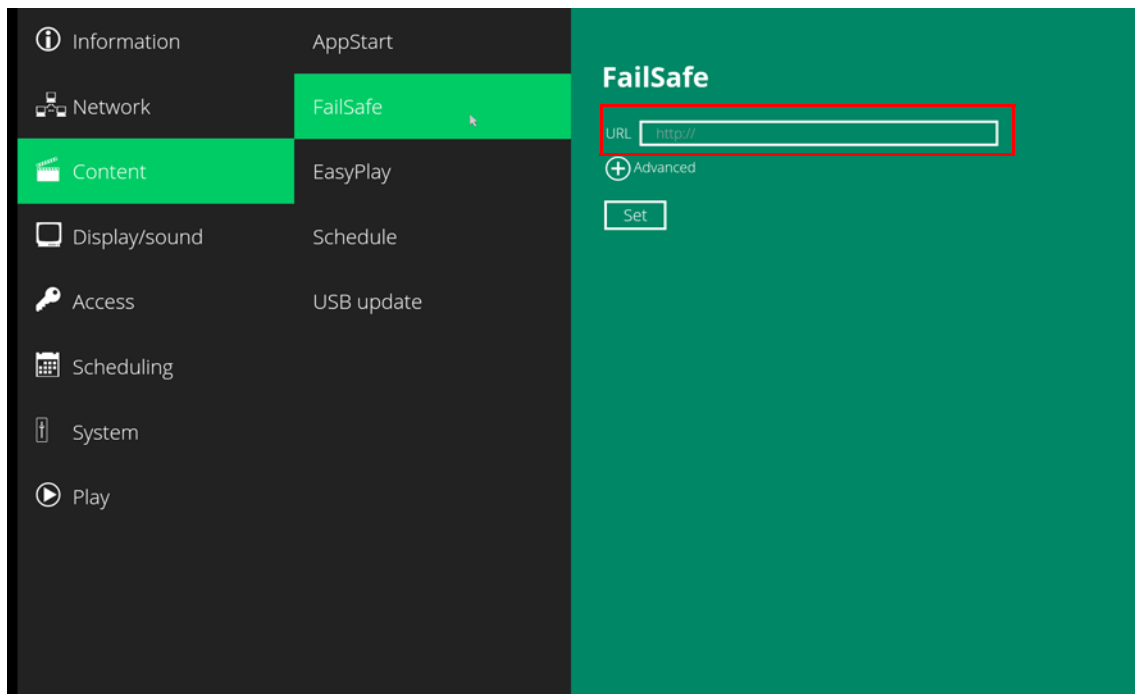



## Content Configuration – EasyPlay

The EasyPlay features allows the player to play media content from the USB flash drive (or microSD card) directly. Please note that media files are not copied to the player's internal storage so the USB flash drive (or microSD card) must not be removed.

When EasyPlay is enabled, the player will play content only from the USB drive (or microSD card). If a user wants to play content from the URL server configured via the **Set content** button, EasyPlay must be disabled.

- 1 Insert the USB drive or microSD card containing the media content to play.
- 2 Click the **Advanced** button.
- 3 Click **Content**, and then click **EasyPlay**.
- 4 Click the **Disabled/Enabled** button to enable EasyPlay and choose from two available operation modes: Photo Mode and Movie Mode.

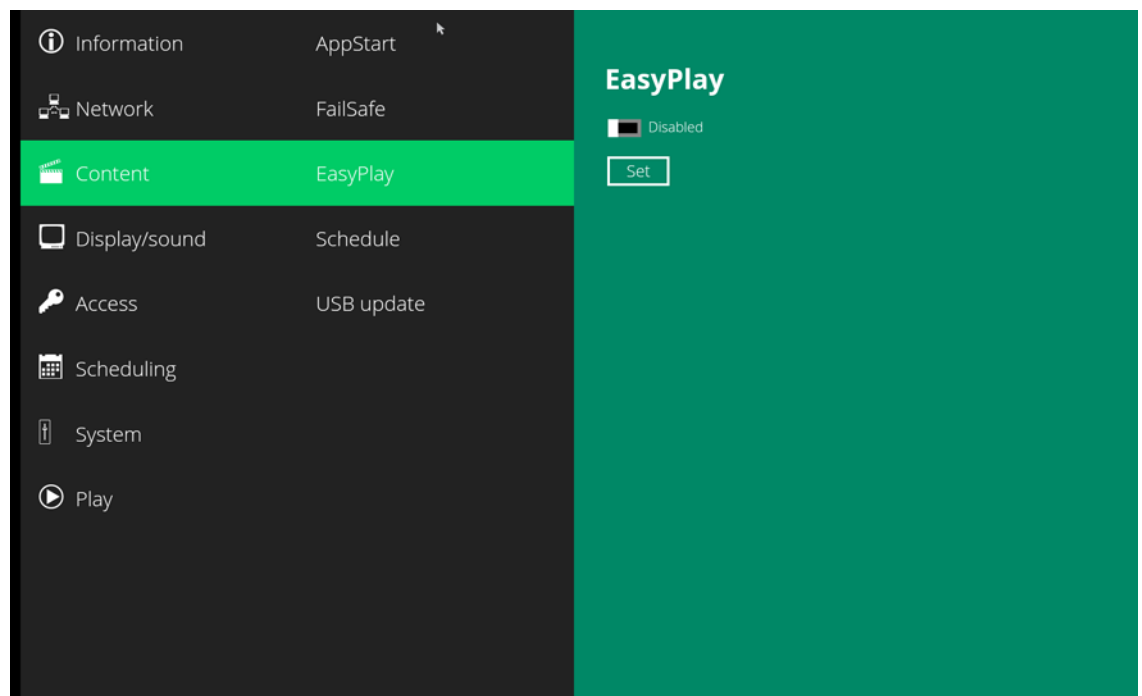

## Configure Photo Mode

- 1 Click **Photo** for choosing photos and music. Click the buttons as marked in red below and select the directories for photos and music from the USB drive.
- 2 Click the **Set** button after selecting the directories.

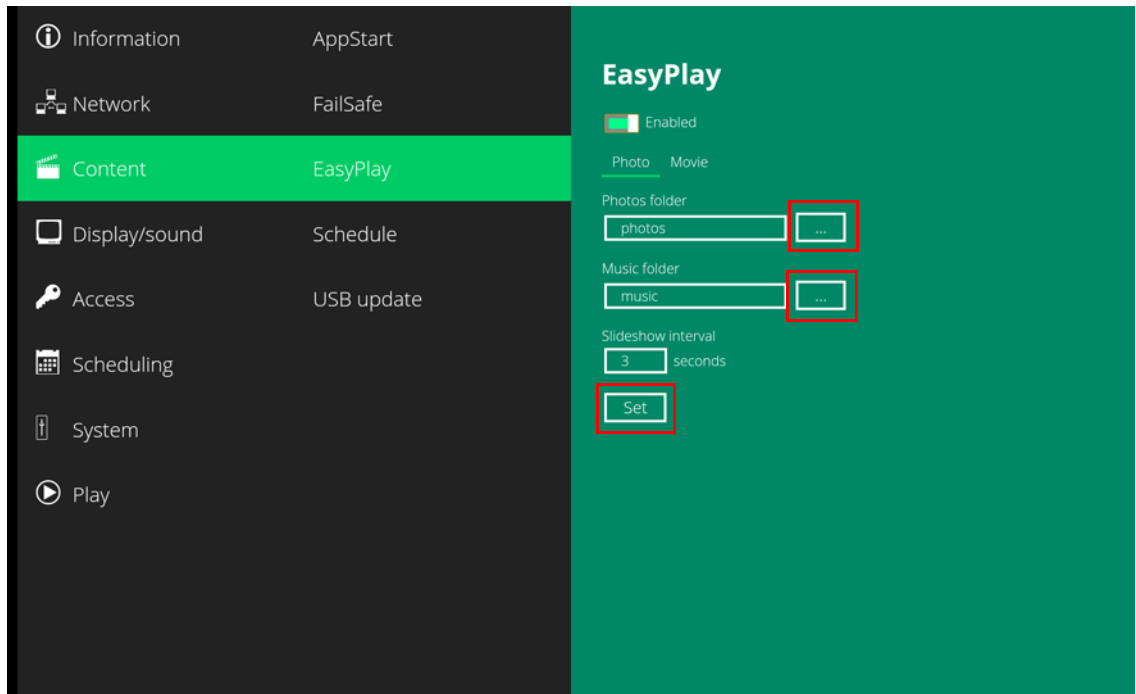

## Configure Movie Mode

- 1 Click **Movie**. Click the button as marked in red below and select the directory for movies from the USB drive.
- 2 Click the **Set** button after the folder is selected.
- 3 The files in the selected folders will be played after clicking the **Play** button in the Basic or Advanced settings menu.

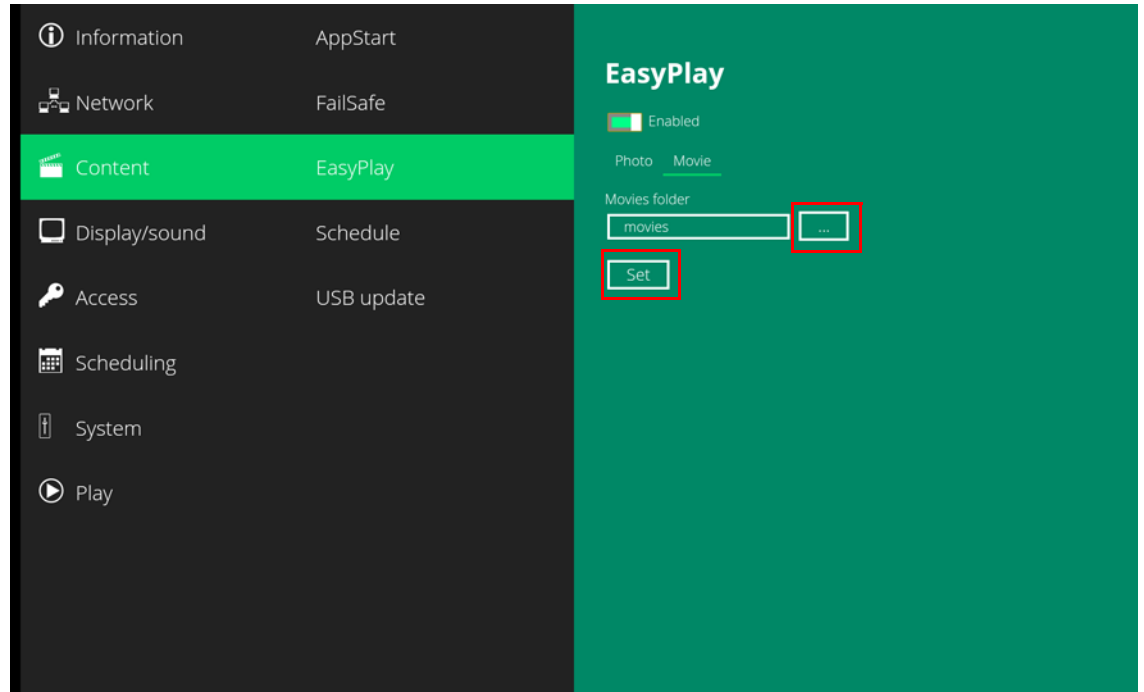

## EasyPlay Schedule Configuration

- 1 Click the **Advanced** button.
- 2 Click **Content**, and then click **Schedule**.
- 3 Click the buttons marked in red below to enable/disable the EasyPlay schedule for each time slots.
- 4 Type the scheduled time in the dialogue boxes marked in blue below by using the pop-up keyboard or the USB keyboard.

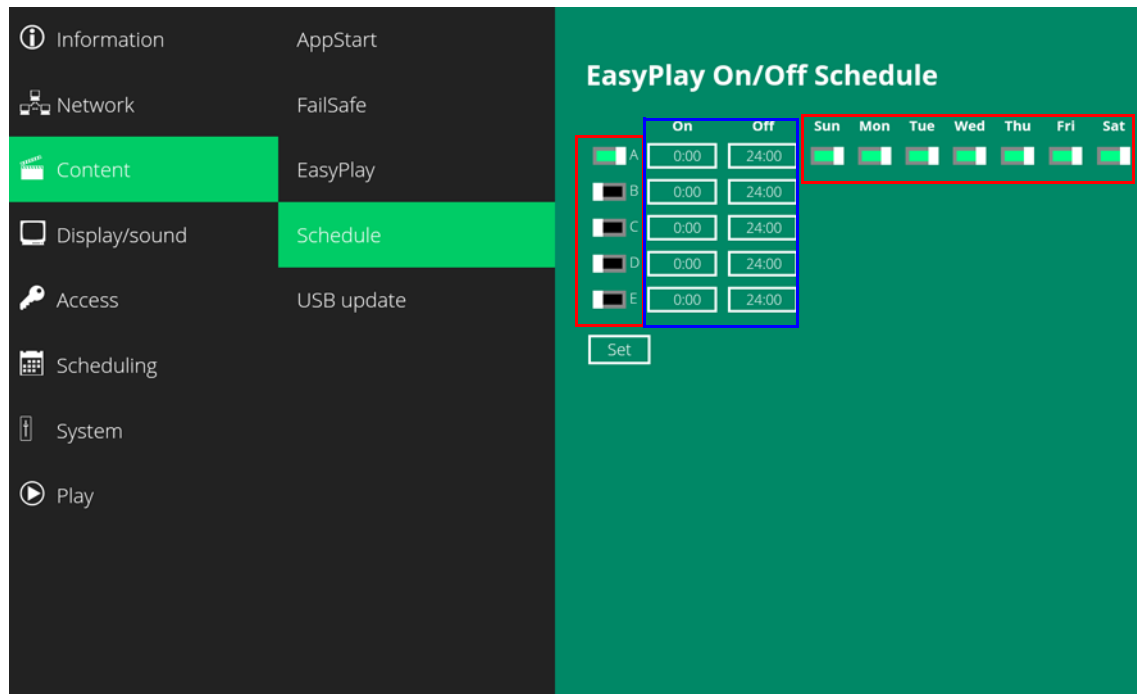

- 5 The “On” times assigned in the time slots A-E are inclusive. For example, a schedule assigned per the example below:

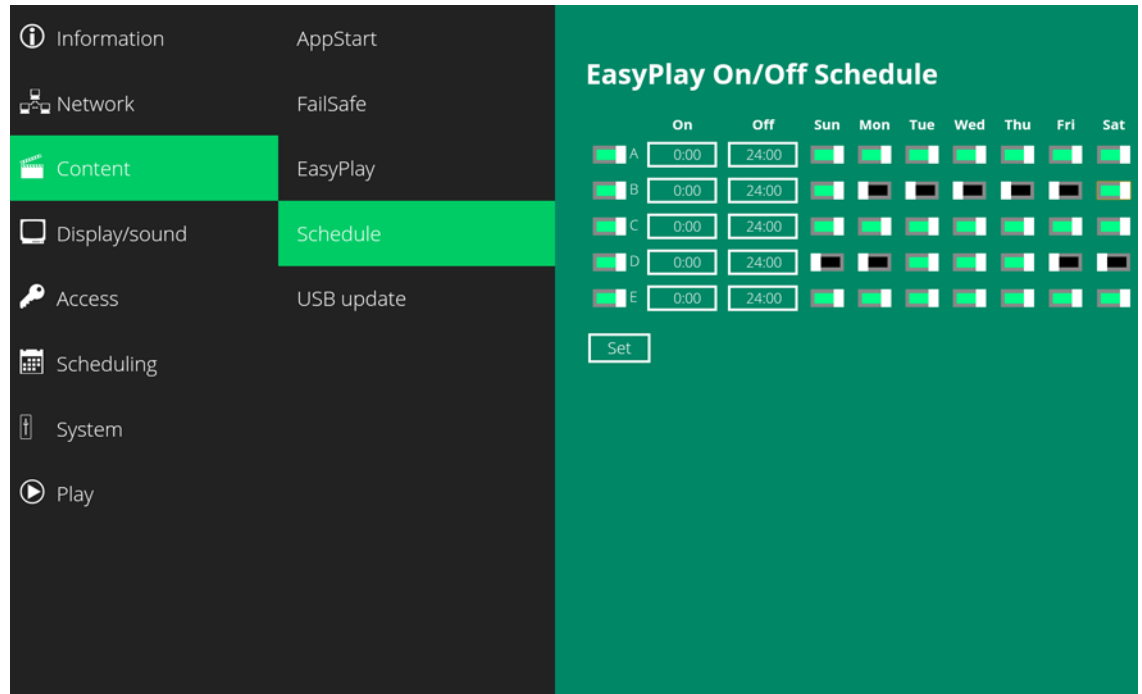

The exact playback time will be the time slots marked in blue as shown below. The dark blue parts are the overlap time of C/D and D/E.

	Sun	Mon	Tue	Wed	Thu	Fri	Sat
00:00							
01:00							
02:00							
03:00							
04:00							
05:00							
06:00							
07:00							
08:00	Blue						Blue
09:00	Blue						Blue
10:00							
11:00	Blue						Blue
12:00	Blue						Blue
13:00	Blue						Blue
14:00	Blue						Blue
15:00							
16:00	Blue						Blue
17:00	Blue		Dark Blue	Dark Blue	Dark Blue		Blue
18:00	Blue		Dark Blue	Dark Blue	Dark Blue		Blue
19:00	Blue		Dark Blue	Dark Blue	Dark Blue		Blue
20:00	Blue		Dark Blue	Dark Blue	Dark Blue		Blue
21:00	Blue						Blue
22:00							
23:00							

**Note:** The display’s scheduling settings can be used instead of the player’s schedule settings. The display’s schedule settings take priority. Refer to the "Schedule Submenu" on page 34.

**Note:** The player’s schedule settings work only if the display is on. If the display has been powered down manually or as a result of Auto Power Off being set to Low Power, the display will not respond to the player’s schedule settings. Refer to the "Power Submenu" on page 31.

## Display Settings

For best quality, the player is configured for the display's native resolution of 3840x2160 @ 60Hz. While it is recommended that the resolution not be changed from this native setting, the following steps can be used to change the resolution of the player.

### Resolution Settings

- 1 Click the **Advanced** button. The advanced configuration menu will be launched.
- 2 Click the **Display/sound** button, and then click **Display**. The Display Settings page will be launched.

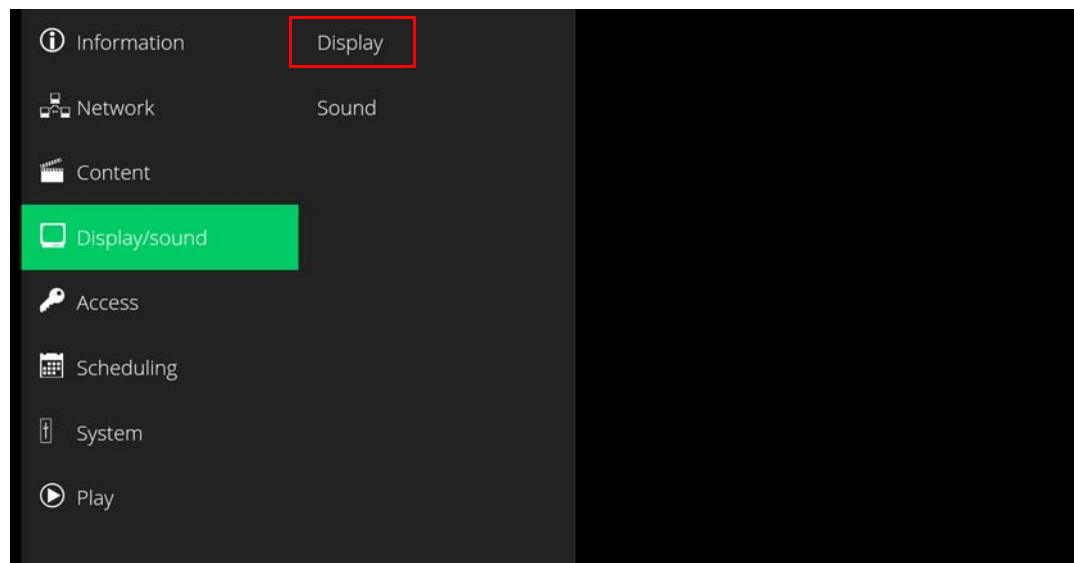

- 3 Click **Resolution** and select a suitable resolution from the pop-up menu. The default configuration is Auto Detect – the player will auto detect and use the best optimized resolution that your display supports.



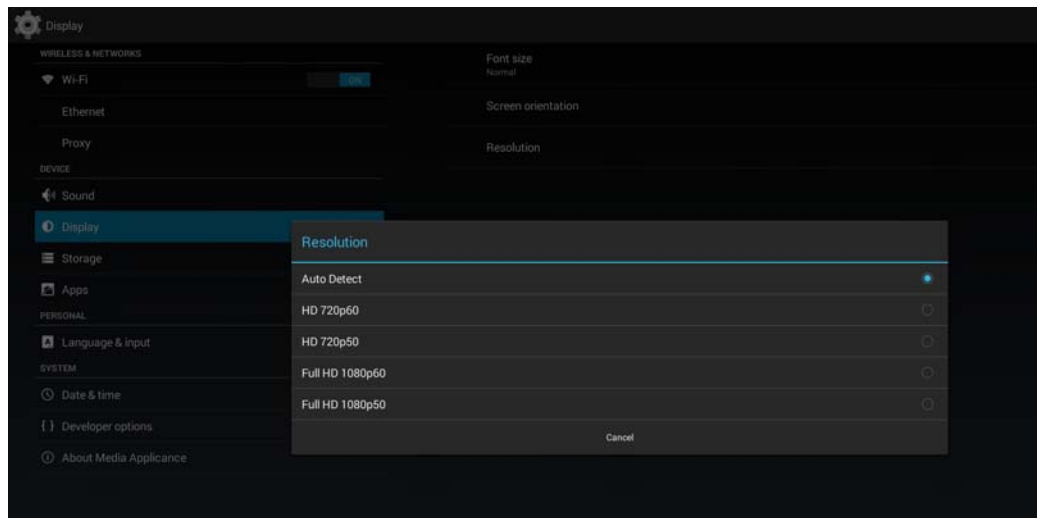

## Screen Orientation

Screen orientation is to set the display to rotate 90/180/270 degrees.

- 1 Click the **Advanced** button. The advanced configuration menu will be launched.
- 2 Click the **Display/sound** button, and then click **Display**. The Display Settings page will be launched.
- 3 Click the Screen orientation marked in red below.

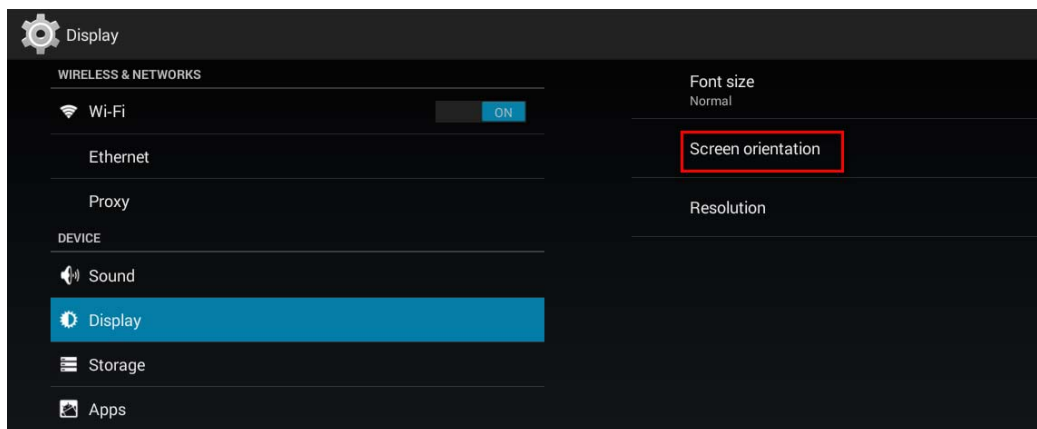

- 4 Select the preferred angle from the menu.

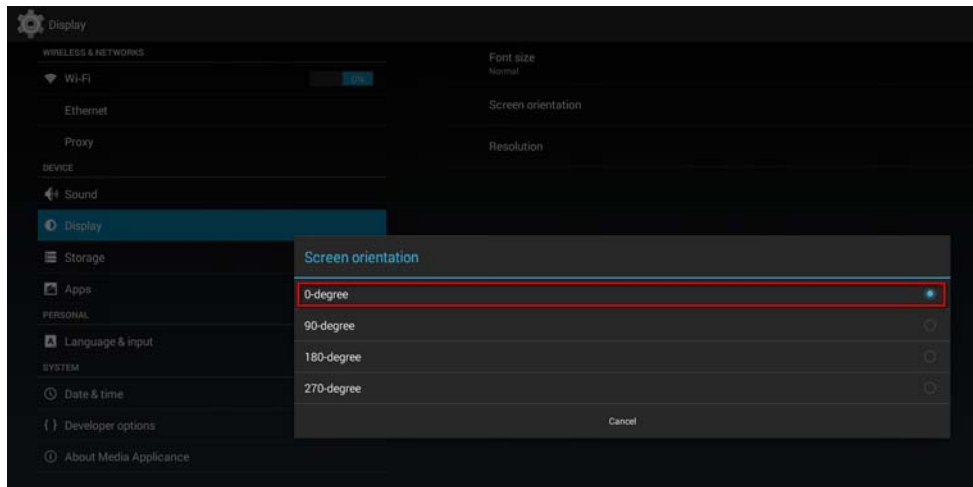

## Sound Settings

To control the output sound volumes and touch sounds:

- 1 Click the **Advanced** button. The advanced configuration menu will be launched.
- 2 Click the **Display/sound** button, and then click **Sound**. The Sound Settings page will be launched.

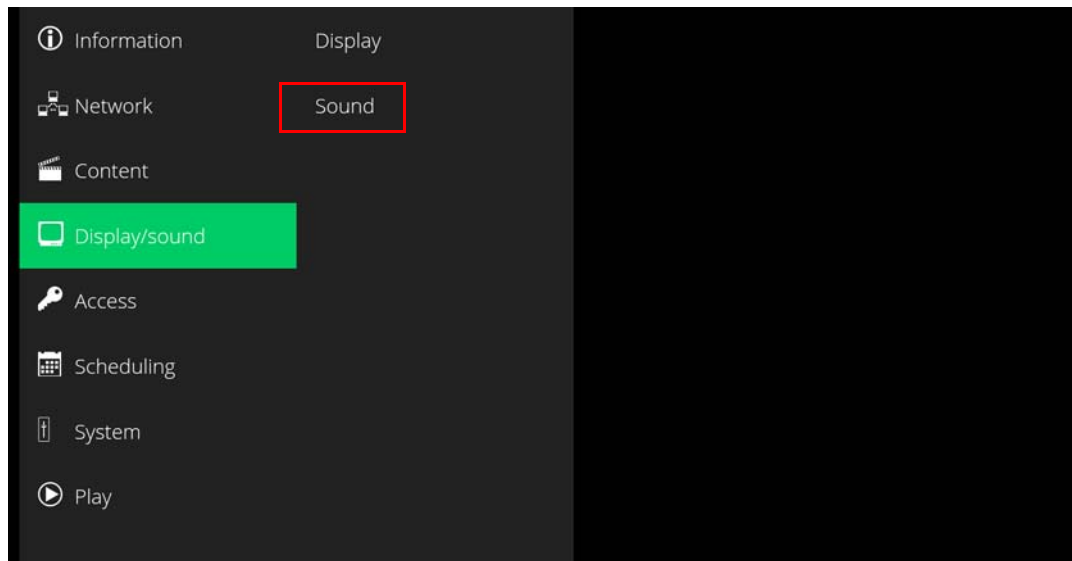



- 3 Click **Volumes**. The Volumes settings page will be launched. Drag the blue sliders to adjust the volumes for the selected options, and then click **OK** to save the new settings.

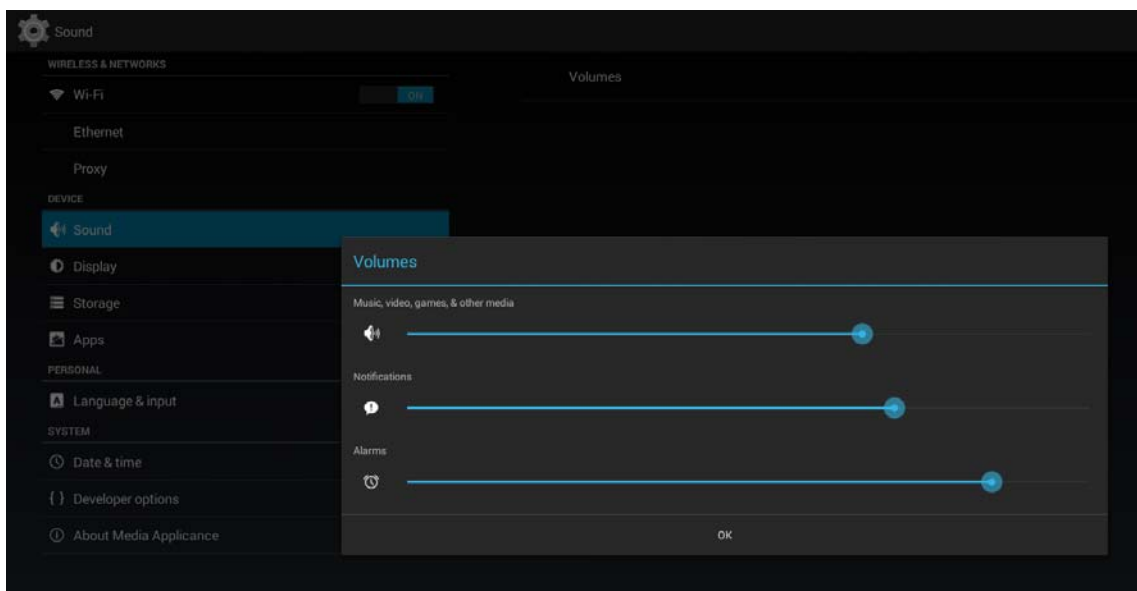
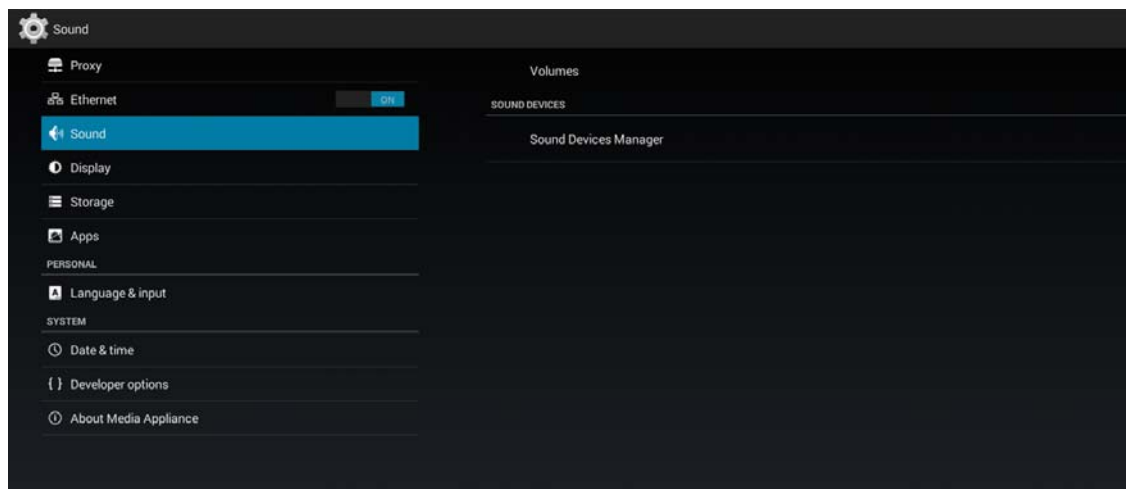

## Access Settings – Player Name

The player's name can be specified so the player can be easily recognized in the management software (Management software support is required).

**Note:** You can also change the player name in the ContentSmart software.

- 1 Click the **Advanced** button. The advanced configuration menu will be launched.
- 2 Click **Access**, and then click **Player** name.
- 3 Input a name for the field and click **Set**.

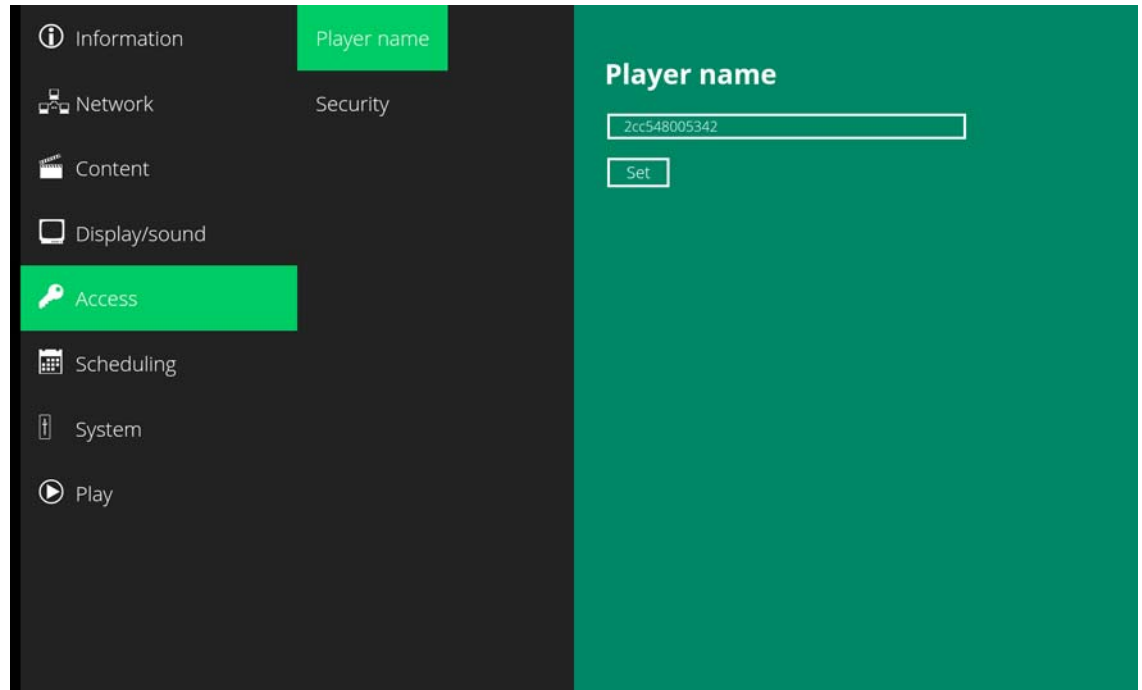

## Access Settings – Security

A password can be set to provide authentication for player access. If the password is set, a password prompt will appear if a user is trying to enter the Basic settings menu from playback.

- 1 Click the **Advanced** button. The advanced configuration menu will be launched.
- 2 Click **Access**, and then click **Security**.
- 3 Input a password in the field and click **Set**.

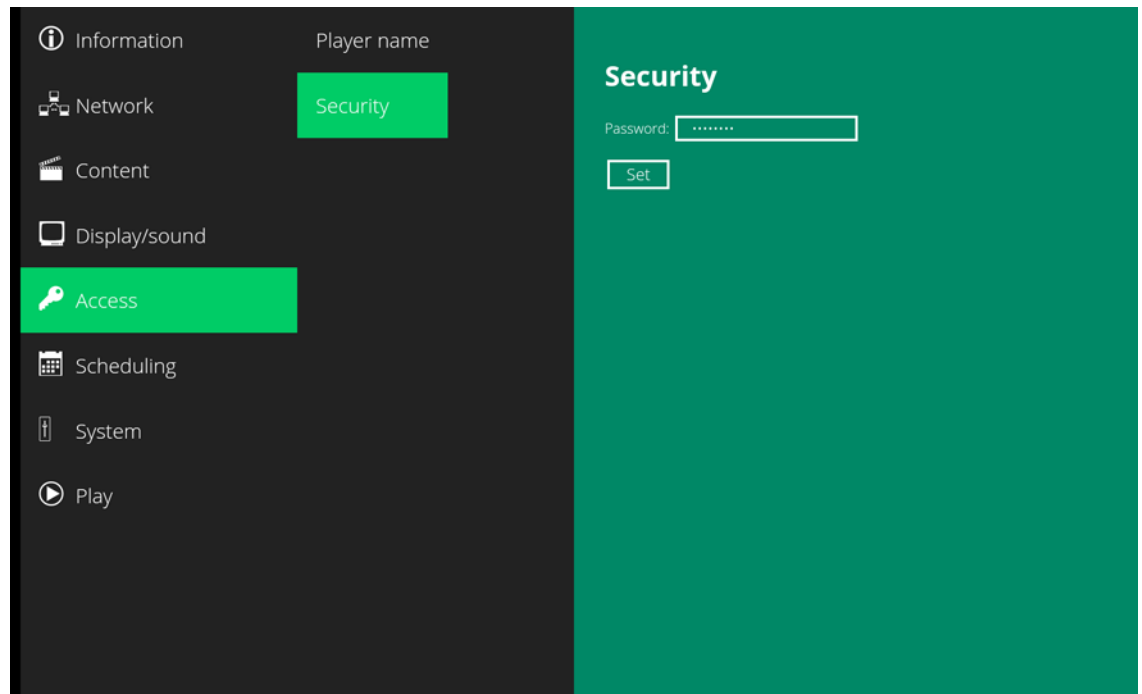

## Scheduling – Time Server

The feature allows users to synchronize the player's time with the web server where the appStart URL hosted (based on the HTTP response header's time). It is disabled by default.

When disabled, the player synchronizes its time with the default time server ([pool.ntp.org](http://pool.ntp.org)).

- 1 Click the **Advanced** button. The advanced configuration menu will be launched.
- 2 Click **Scheduling**, and then click **Time server**.
- 3 Click the **Use AppStart URL as time server** button as marked in red below to enable/disable the time server function.
- 4 Click **Set** to save the setting.

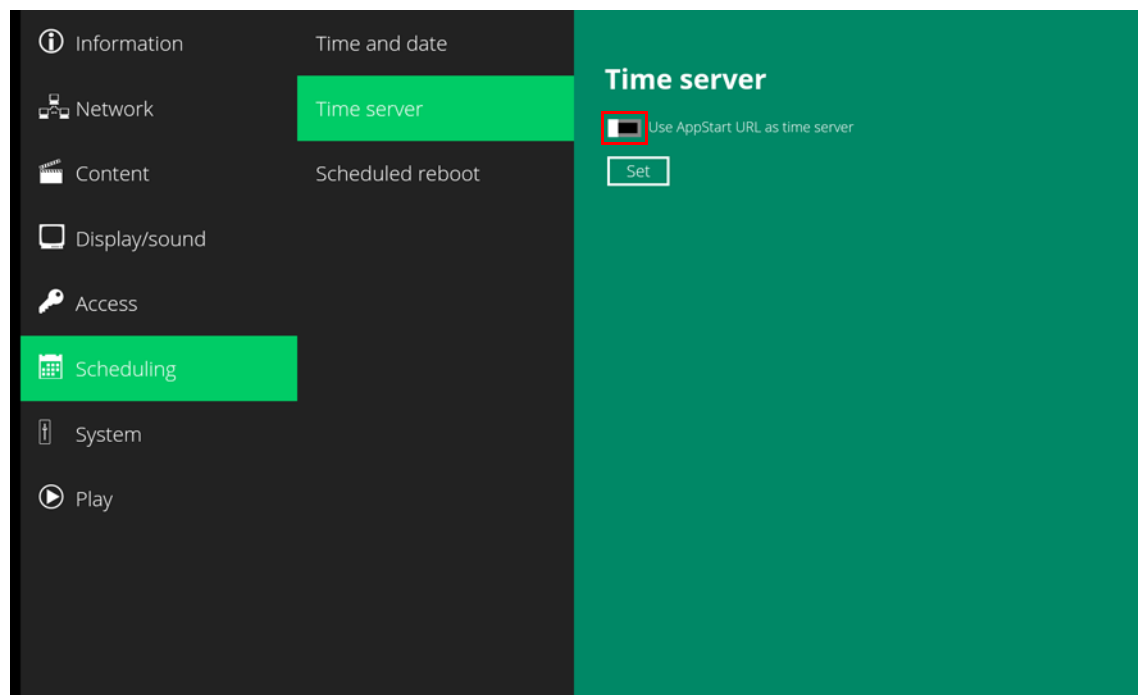

## Scheduling – Scheduled Reboot

The Scheduled Reboot feature allows the player to reboot on the assigned time automatically every day.

**Note:** The Scheduled Reboot feature affects only the player, not the entire display. To reboot the entire display, use the Scheduling feature in the main OSD. Refer to "Schedule Submenu" on page 34.

- 1 Click the **Advanced** button. The advanced configuration menu will be launched.
- 2 Click **System**, and then click **Scheduled Reboot**.
- 3 Click the **Enable daily reboot** button as marked in red below to enable/disable the daily reboot function. Click the dialogue box to set the time. The value can be entered with the pop-up keyboard or USB keyboard.
- 4 Click **Set** to save the setting.

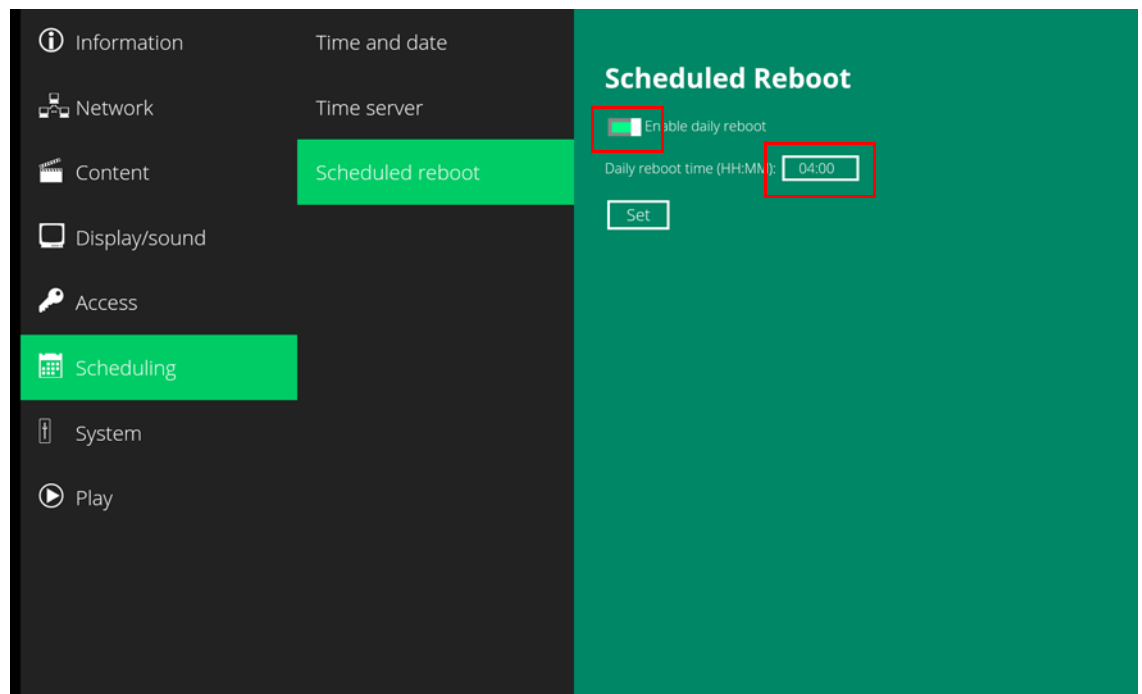

## System Configuration – Firmware Update

Firmware updates can be performed by using a USB flash drive. Please read the release notes regarding the changes that will be made to your player before applying the upgrade.

**IMPORTANT: DO NOT** unplug the USB drive or power down the player while the system is performing the firmware update.

- 1 Download the latest firmware from <http://www.planar.com/contentsmart> and copy it to the root directory of a USB drive.
- 2 Plug in the power cord into the device.
- 3 After the bootup completes, click the **Advanced** button on the Basic settings menu.
- 4 Click **System**, and then click **Firmware** update.
- 5 Click **OK** to begin the firmware update.

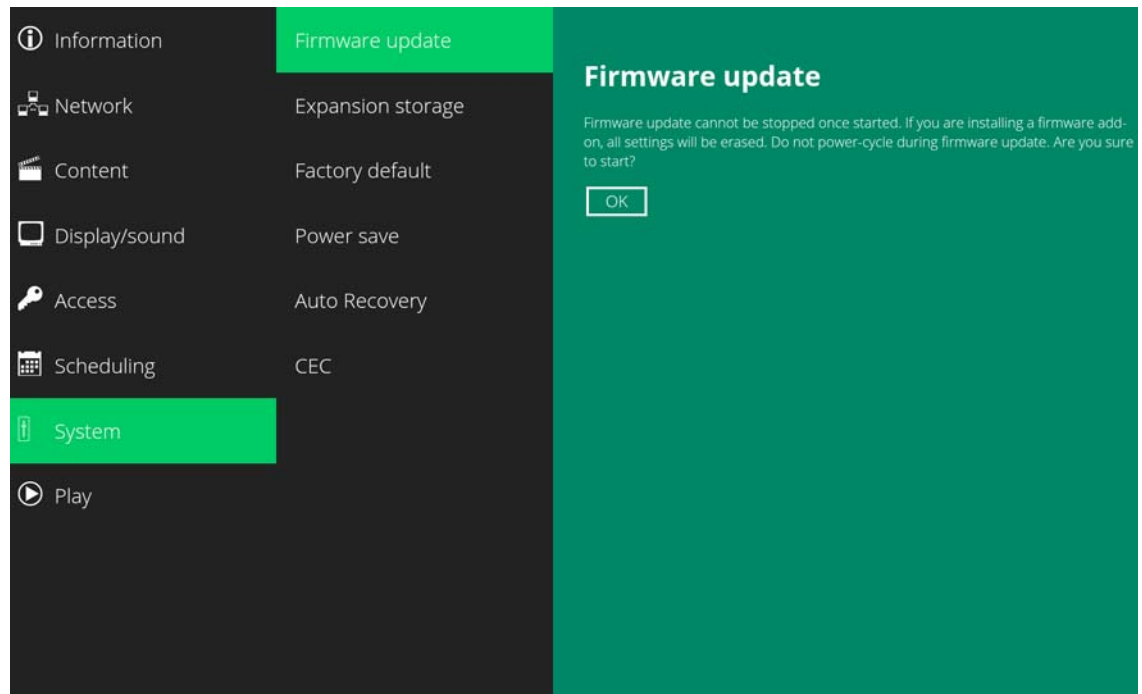

- 6 Plug in the USB drive while the screen shows “Scanning USB drives for firmware package.” Make sure to use one of the player’s USB inputs, not the main USB-A input.

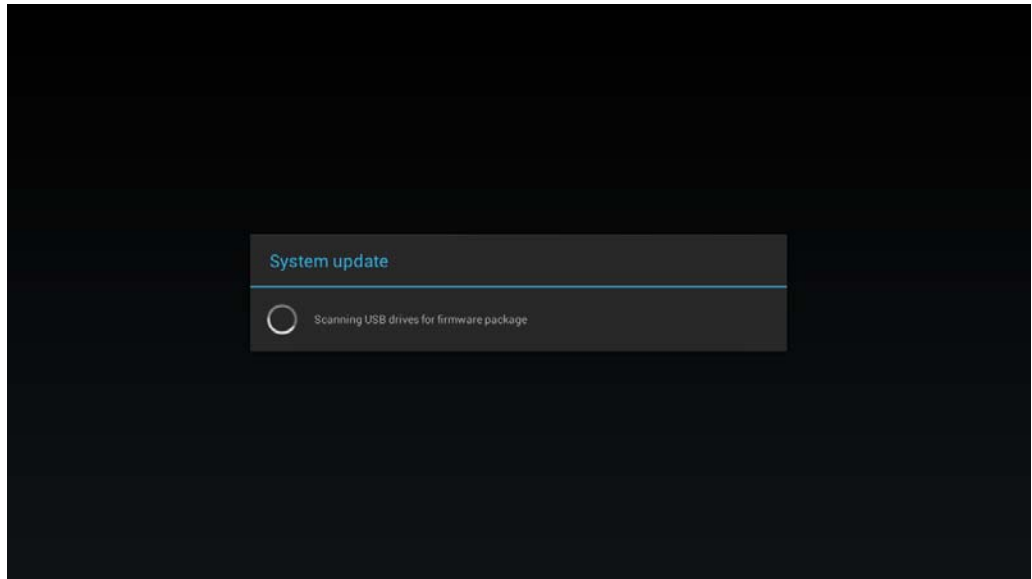

## System Configuration – Expansion Storage

### Manual Expansion

- 1 Power off the device.
- 2 Insert the microSD card, and then plug in the power cord to power on.
- 3 In the Basic settings menu, click the **Advanced** button. The advanced configuration menu will be launched.
- 4 Click **System**, click **Expansion storage** and click **Initialize**. The player will format the microSD card and then reboot automatically.

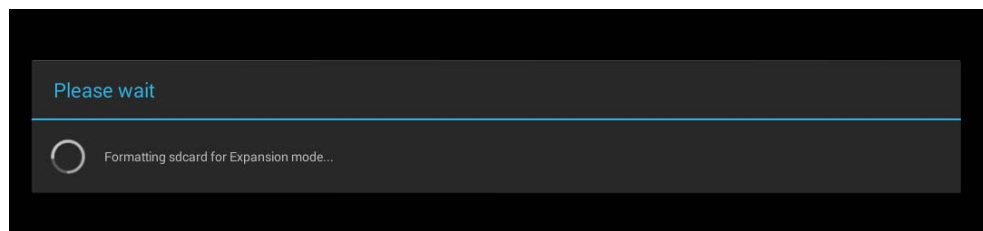
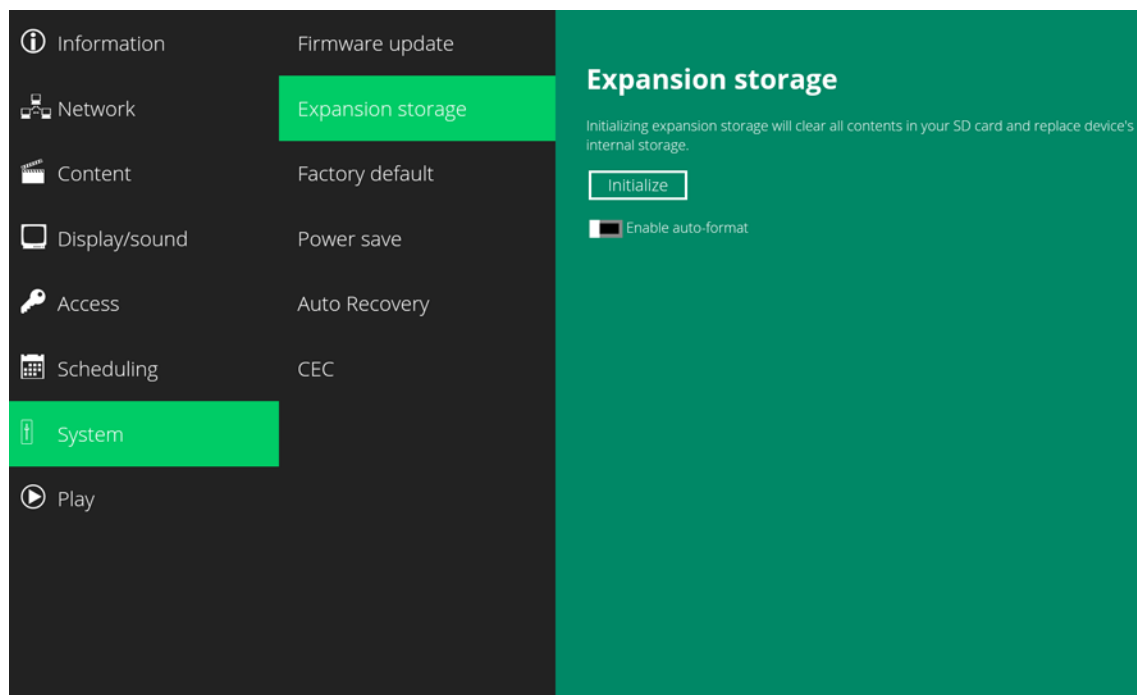

- 5 After bootup, check the player information. The new capacity will be displayed.



## Auto Expansion

- 1 In the Basic settings menu, click the **Advanced** button. The advanced configuration menu will be launched.
- 2 Click **System**, click **Expansion storage** and enable **auto-format**.

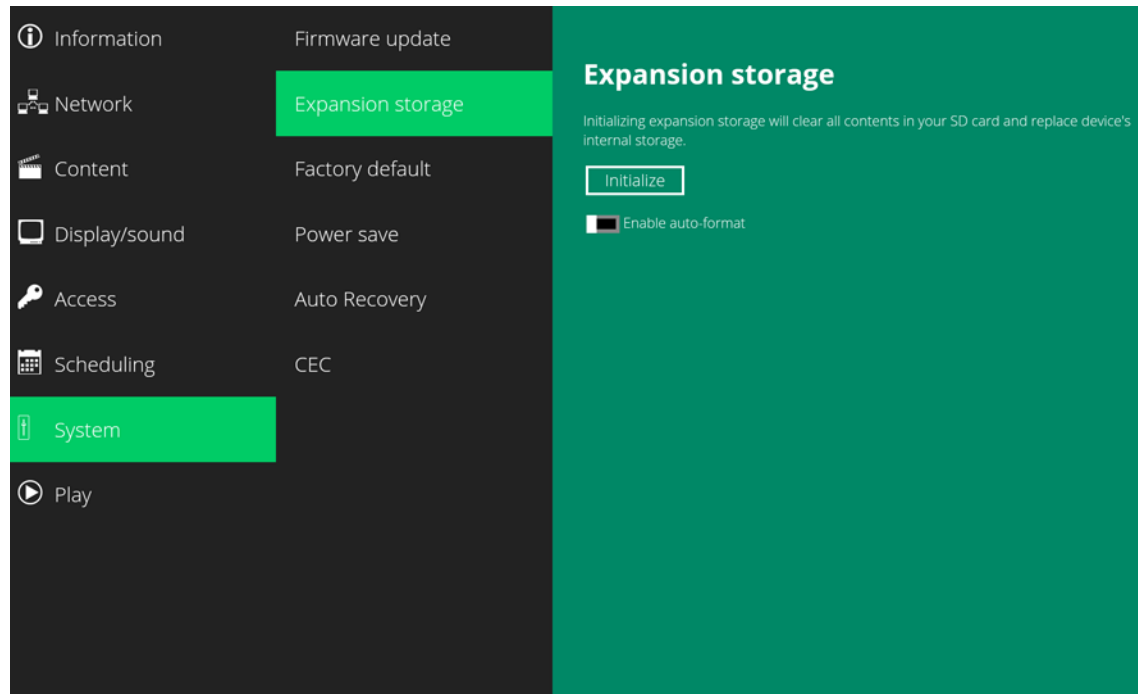

- 3 Power off the device.
- 4 Insert the microSD card, and then plug in the power cord to power on.
- 5 After bootup, check the player information. The new capacity will be displayed.

## System Configuration – Factory Reset

If you forget the system password you have set, you must reset the system to regain access to the player.

### Using the Reset Button

- 1 Press and hold the reset button with a pin.
- 2 Reconnect the power cord.
- 3 Wait until the status LED flashes.
- 4 Release the reset button and wait for the system to initialize.

### Using a USB Mouse

A system reset will re-initialize the system, clear passwords and return settings to their default values. Perform the following:

- 1 Connect a USB mouse or use the touch screen for input.
- 2 Click the **Advanced** button. The advanced configuration menu will be launched.
- 3 Click **System**, and then click **Factory default**.
- 4 Click the **OK** button to perform the system reset.

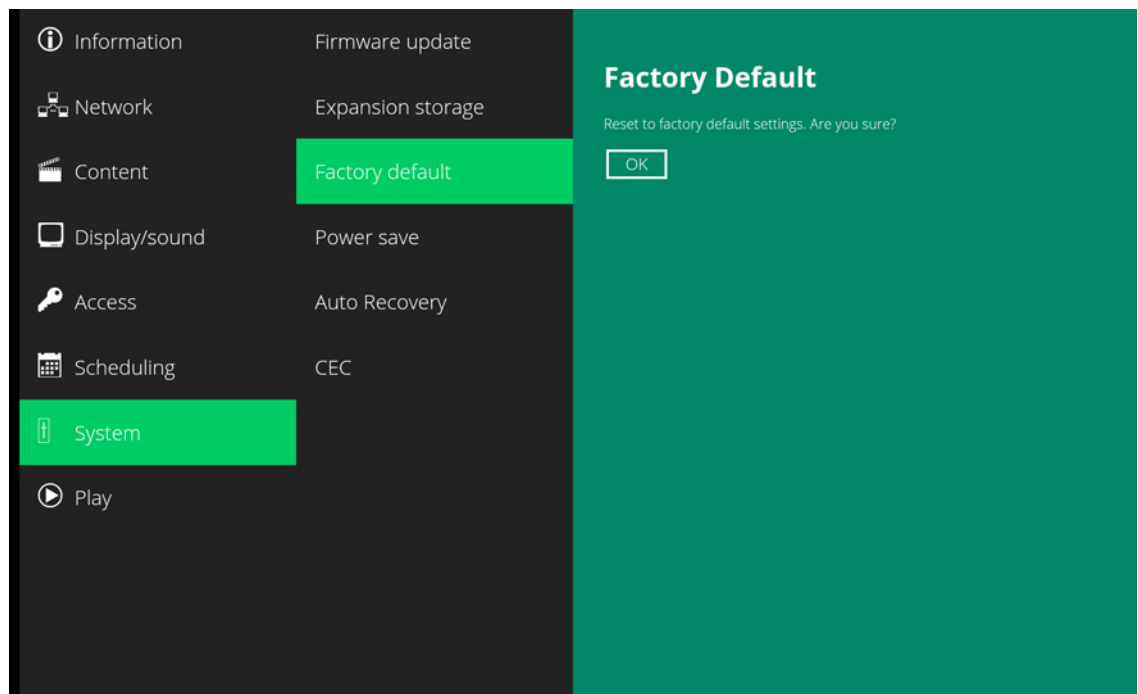

## System Configuration – Power Save

The Power Save feature allows the player to power off automatically while staying at the Basic settings menu without any action taken for 10 minutes.

- 1 Click the **Advanced** button. The advanced configuration menu will be launched.
- 2 Click **System**, and then click **Power save**.
- 3 Click the **Enable Power Save mode** button as marked in red below to enable/disable the power save function.
- 4 Click **Set** to save the setting.

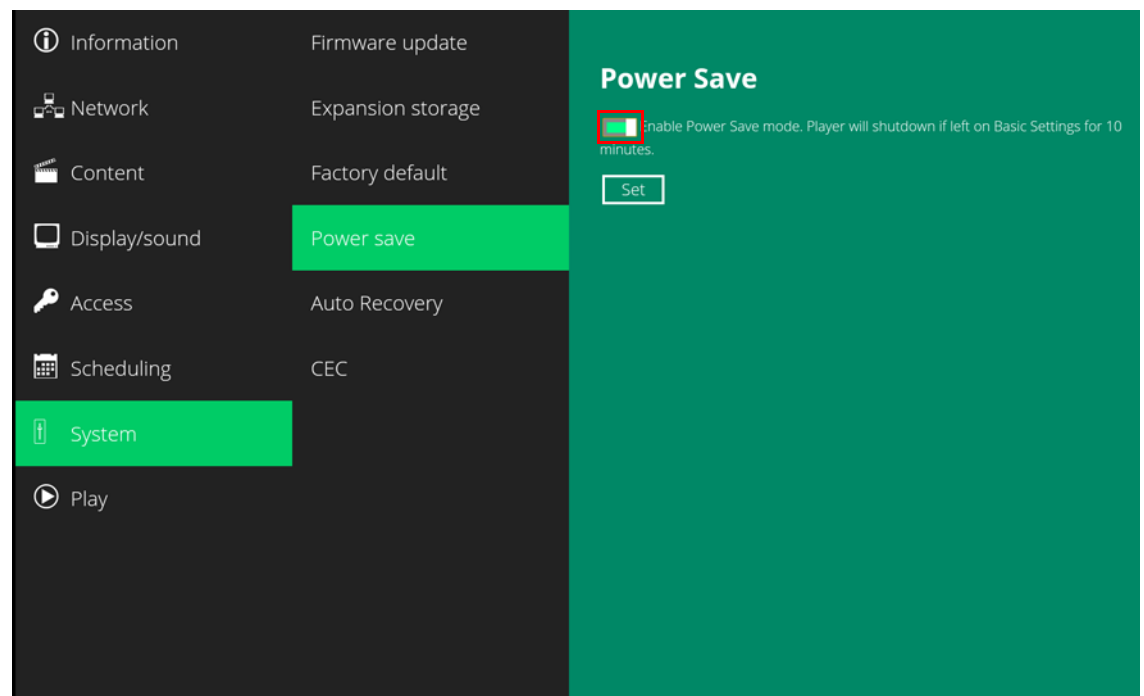

## System Configuration – Auto Recovery

Auto recovery defines what should happen if there is an issue with the loaded content. Should an error occur while playing content which could include things such as custom widgets and HTML5 content, the user may specify whether or not they would like the player to attempt to re-start the content (setting is on) or cancel to the main menu (setting is off). The default setting for this feature is on.

- 1 Click the **Advanced** button. The advanced configuration menu will be launched.
- 2 Click **System**, and then click **Auto Recovery**.
- 3 Enable or disable the auto recovery function.

## Content Management

Please refer to the *Planar ContentSmart Software User Manual* for instructions.

## Authoring in HTML5

A major advancement in the player is the ability to playback HTML5 content which can contain dynamic information.

To find out more about using HTML5 for digital signage, visit <http://www.digisignage.com/>

## Working with SMIL

The player uses open communications protocols for content presentation and playback control.

SMIL-compliance means predictable results across multiple devices. SMIL's non-proprietary nature means that your investments are never obsolete.

### Introduction

Using SMIL (pronounced "smile"), the language created by W3C for multimedia communications, the media player understands the language "spoken" by professional tools from companies such as Adobe, Apple, Microsoft, and Real Networks. What this means is quicker, easier, and better integration of your players into your digital signage networks, opening up avenues of software controls and realizing the full potential of your player hardware down the road.

### [www.a-smil.org](http://www.a-smil.org) for Developers

The media player operating system utilizes W3C SMIL as the underlying scripting language, which lends well to customization to your project management needs. For resources, downloads and community support, visit [www.a-smil.org](http://www.a-smil.org).

# Planar QE Series Remote Monitoring Software

Planar QE Series Remote Monitoring is a software tool that displays information about the display via a web browser. It is used primarily to access the settings in the OSD as well as provides some additional features.

## Remote Monitoring Home

Launch a web browser. Enter the IP address shown in the Network menu (see page 32). If successful, you should see the Remote Monitoring System Information page.

## Remote Monitoring System Information

This page displays version information for all programmable parts in the system. It also contains the model and serial number.

For the OSD equivalent, refer to "System Settings Submenu" on page 42.

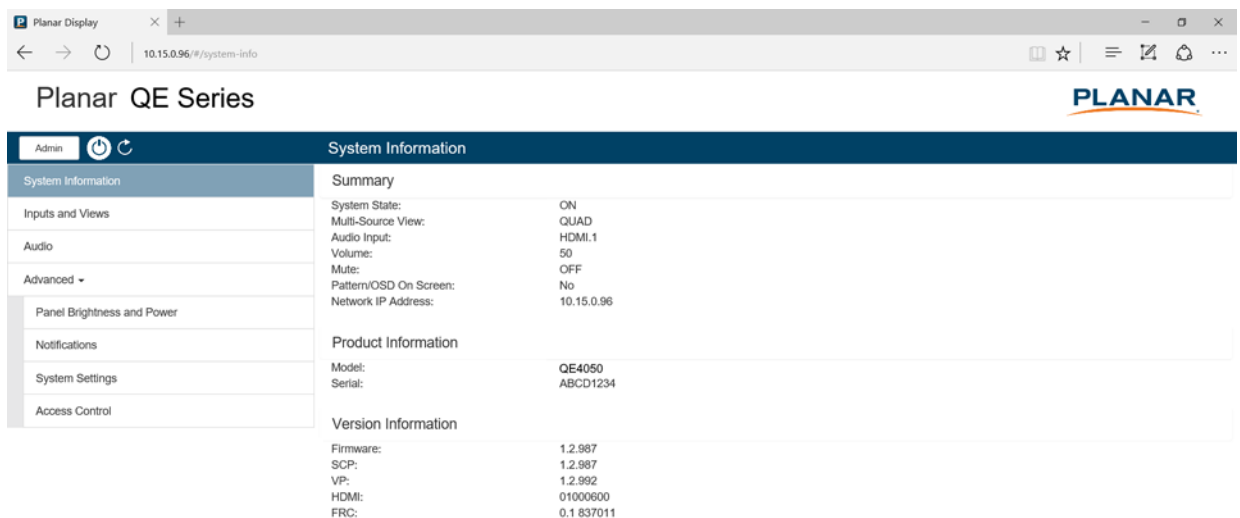

The screenshot shows a web browser window displaying the Planar QE Series Remote Monitoring System Information page. The page has a dark blue header with the Planar logo and the title "Planar QE Series". Below the header is a navigation menu with "Admin" and "System Information" (selected). The main content area is divided into three sections: Summary, Product Information, and Version Information.

Summary	
System State:	ON
Multi-Source View:	QUAD
Audio Input:	HDMI.1
Volume:	50
Mute:	OFF
Pattern/OSD On Screen:	No
Network IP Address:	10.15.0.96

Product Information	
Model:	QE4050
Serial:	ABCD1234

  

Version Information	
Firmware:	1.2.987
SCP:	1.2.987
VP:	1.2.992
HDMI:	01000600
FRC:	0.1.837011

## Remote Monitoring Inputs and Views

This page shows how the sources will be laid out on the screen based on the current Multi-Source View and Advanced Layouts selections.

For the OSD equivalent, refer to "Inputs and Views Menu" on page 23.

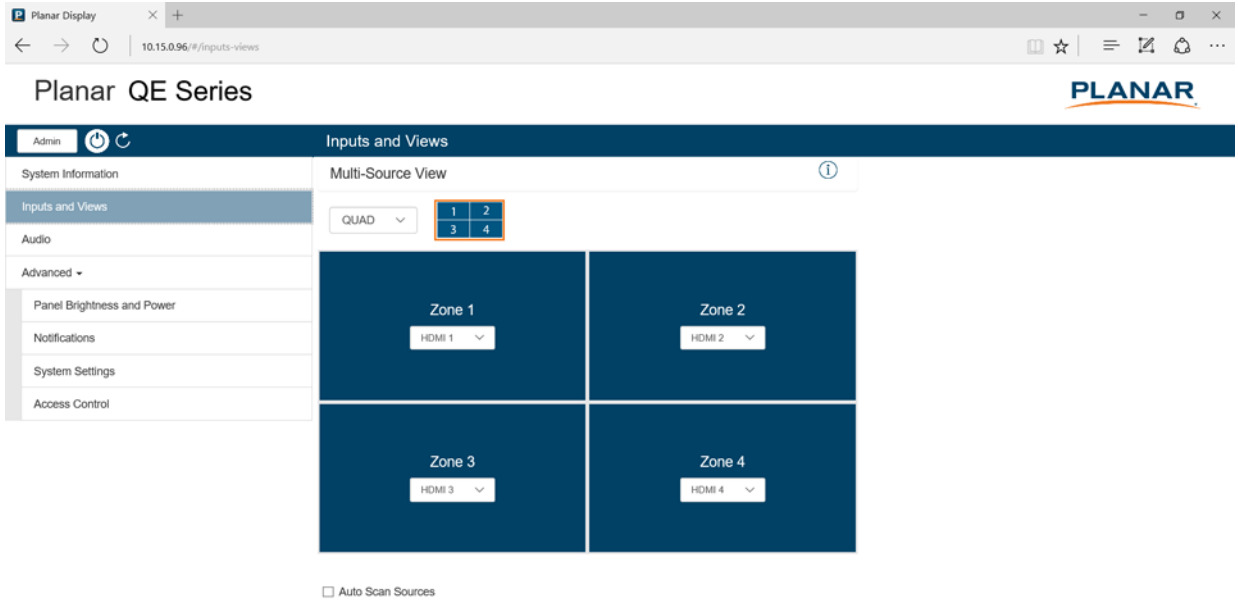

# Remote Monitoring Audio

This page enables you to make audio adjustments to the selected zone.

**Note:** Volume, Bass, Treble and Balance do not apply to the S/PDIF output.

For the OSD equivalent, refer to "Audio Menu" on page 28.

The screenshot shows a web browser window displaying the Planar QE Series audio settings page. The browser's address bar shows the URL `10.15.0.96/#/audio`. The page title is "Planar QE Series" and the PLANAR logo is in the top right corner. The interface has a dark blue header with "Admin" and "Audio" tabs. A left sidebar contains a navigation menu with items: System Information, Inputs and Views, Audio (selected), Advanced, Panel Brightness and Power, Notifications, System Settings, and Access Control. The main content area is titled "Audio" and shows the following settings:

- Audio Input: HDMI.1
- Audio Select: Zone 1
- Volume: 50
- Mute:
- Treble: 50
- Bass: 50
- Balance: 50
- Enable Internal Speakers:

## Remote Monitoring Panel Brightness and Power

This page enables you to make adjustments to the brightness and power settings.

For the OSD equivalents, refer to "Panel Brightness Submenu" on page 30 and "Power Submenu" on page 31.

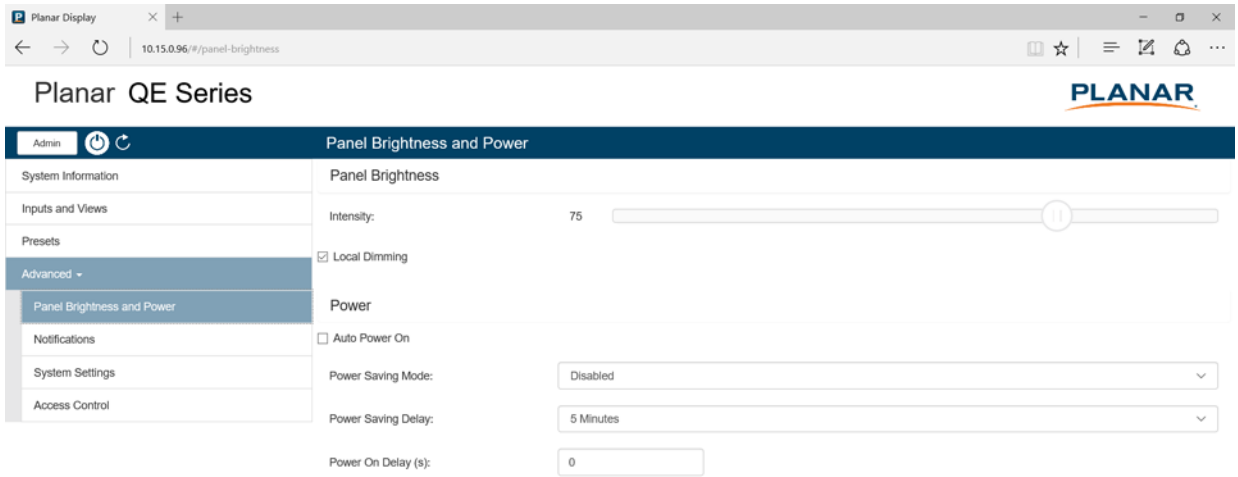



# Remote Monitoring Notifications

This page enables you to send email notifications on certain events.

The screenshot shows the 'Planar QE Series' web interface. The 'Notifications' section is active, displaying 'Email Account Settings' and 'Notification Events'.

**Email Account Settings:**

- SMTP Server: smtp.comcast.net
- Connection Encryption: TLS
- Port: 465
- Authentication: Auto
- User Name: mgirardelli
- Password: server login password
- Email From Address: mgirardelli@comcast.net

**Notification Events:**

Event	Recipient(s)	Additional Note	Enabled
Power On/Off	marques.girardelli@planar.com	Testing 12345678	<input type="checkbox"/>
System Error			<input type="checkbox"/>

**Note:** Obtain this information from your ISP or network administrator.

The options under **Email Account Settings** are:

- **SMTP Server:** The name of the outgoing SMTP server. Obtain this information from your ISP.
- **Connection Encryption:** Selects the appropriate encryption method required by the SMTP server.
- **Port:** Selects the port that the SMTP server uses.
- **Authentication:** Use Auto unless directed by your ISP or network administrator.
- **User Name:** Login username for the SMTP server.
- **Password:** Login password for the SMTP server.
- **Email From Address:** The email address that will be shown in the "From:" field of the notification emails.

The options under **Notification Events** are:

- **Power On/Off:** Occurs when standby mode is entered and when the display is powered on.
- **System Error:** Occurs when the display has detected an error within the system.
- **Source Detect:** Occurs when the display detects and displays a new input signal.
- **Source Lost:** Occurs when the current input signal is no longer detected.
- **Source Selected:** Occurs when a different input source is selected for any of the zones.

**Note:** Each event can be sent to one or more recipients. To add multiple email addresses, separate them by a space.

- **Test Email:** Sends a test of the selected email notification. This is useful for verifying that your email account settings are setup correctly. If the test email fails, you can use the **View Last 10 Log Messages** button to get more detailed information about the failure.

## Remote Monitoring System Settings

This page enables you to make adjustments to a variety of system settings.

For the OSD equivalent, refer to "System Settings Submenu" on page 42.

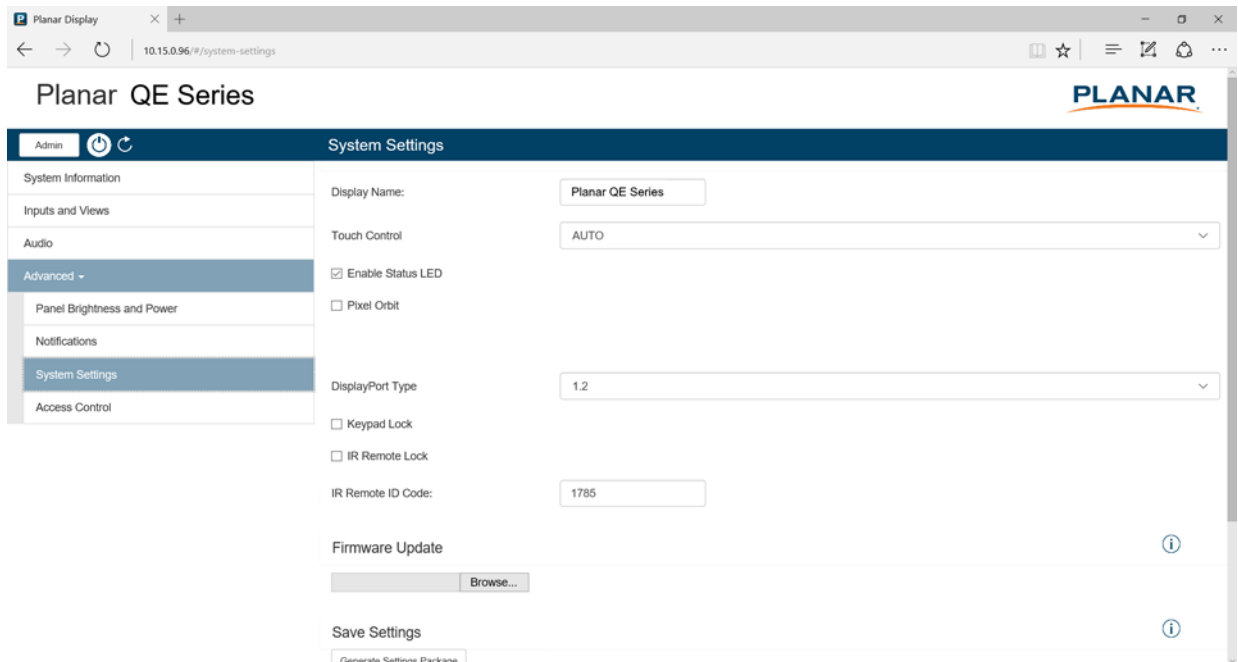

## Remote Monitoring Access Control

This page enables you to limit the ability to access certain features in the web server by password protecting them.

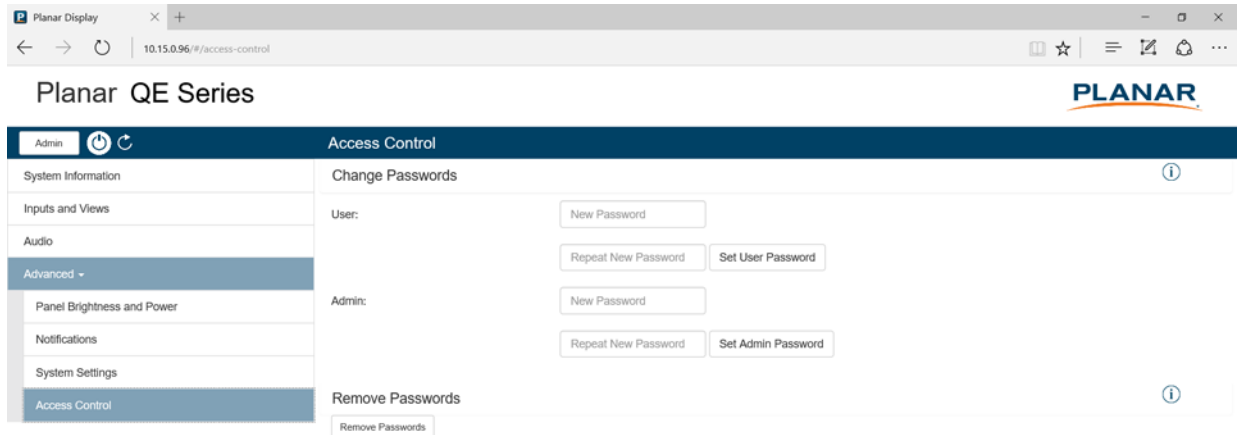

All functions other than the following require Admin level access:

- Power On/Off
- System Information
- Inputs and Views
  - Multi-Source View
  - Zone inputs
- Audio
  - Volume
  - Mute
- Panel Brightness and Power
  - Panel Brightness

With the exception of System Information, all functions listed above require User level access.

If no password is set for either access level, all functions can be accessed. By default, there are no passwords for either access level.

# External Control

In addition to using the Planar QE Series remote control and display, there are other methods of controlling the Planar QE Series display externally:

- Using a serial link to send ASCII commands and to receive responses to those commands. The same set of commands can be sent over RS-232, USB, TCP or UDP. See the *Planar QE Series RS232 User Manual* for more information.
- Using discrete infrared (IR) codes to program a third-party remote control. See "IR Command Protocol" on page 17.
- Using the Planar QE Series Remote Monitoring software to access the settings in the OSD as well as some additional features via a web browser. See "Planar QE Series Remote Monitoring Software" on page 79.

# Signal Compatibility

Signal Type	Resolution	Frame rate (Hz)	Line Rate (kHz)	Pixel Rate (MHz)	HDMI 1-2	HDMI 3-4	DisplayPort	References
PC	640x480	59.94	31.469	25.175	x	x	x	VESA DMT, CEA-861-F Format 1
	640x480	72	37.861	31.500	x	x	x	VESA DMT
	640x480	74.99	37.500	31.500	x	x	x	VESA DMT
	640x480	85	43.269	36.000	x	x	x	VESA DMT
	800x600	60.32	37.890	40.000	x	x	x	VESA DMT
	800x600	72	48.077	50.000	x	x	x	VESA DMT
	800x600	75	46.875	49.500	x	x	x	VESA DMT
	800x600	85.06	53.674	56.250	x	x	x	VESA DMT
	848x480	59.659	29.830	31.500	x	x	x	VESA CVT
	848x480	74.769	37.684	41.000	x	x	x	VESA CVT
	848x480	84.751	42.969	46.750	x	x	x	VESA CVT
	1024x768	60	48.363	65.000	x	x	x	VESA DMT
	1024x768	70	56.476	75.000	x	x	x	VESA DMT
	1024x768	75.03	60.023	78.750	x	x	x	VESA DMT
	1024x768	85.03	68.677	94.500	x	x	x	VESA DMT
	1152x864	70.012	63.851	94.500	x	x	x	VESA DMT
	1152x864	75	67.500	108.000	x	x	x	VESA DMT
	1152x864	84.999	77.094	121.500	x	x	x	VESA DMT
	1280x768	49.929	39.593	65.250	x	x	x	VESA CVT
	1280x768	59.995	47.396	68.250	x	x	x	VESA CVT-R
	1280x768	60	47.776	79.500	x	x	x	VESA CVT
	1280x768	74.893	60.289	102.250	x	x	x	VESA CVT
	1280x768	84.837	68.633	117.500	x	x	x	VESA CVT
	1280x960	60	60.000	108.000	x	x	x	VESA DMT
	1280x960	75	75.000	126.000	x	x	x	VESA DMT
	1280x960	85.002	85.938	148.500	x	x	x	VESA DMT
	1280x1024	60.02	63.981	108.000	x	x	x	VESA DMT
	1280x1024	75.02	79.976	135.000	x	x	x	VESA DMT
	1280x1024	85.02	91.146	157.500	x	x	x	VESA DMT
	1360x768	60	47.712	85.500	x	x	x	VESA DMT

Signal Type	Resolution	Frame rate (Hz)	Line Rate (kHz)	Pixel Rate (MHz)	HDMI 1-2	HDMI 3-4	DisplayPort	References
PC	1400x1050	49.965	54.113	100.000	x	x	x	VESA CVT
	1400x1050	60	64.7	101.00	x	x	x	VESA CVT-R
	1400x1050	60	65.317	121.750	x	x	x	VESA CVT
	1400x1050	74.867	82.278	156.000	x	x	x	VESA CVT
	1600x1200	60	75.000	162.000	x	x	x	VESA DMT
	1920x1080	49.929	55.621	141.500	x	x	x	VESA CVT
	1920x1080	59.963	67.158	173.000	x	x	x	VESA CVT
	1920x1080	59.950	66.587	138.500	x	x	x	VESA CVT-R
	1920x1200	49.932	61.816	158.250	x	x	x	VESA CVT
	1920x1200	59.950	74.038	154.000	x	x	x	VESA CVT-R
	1680x1050	49.974	54.121	119.500	x	x	x	VESA CVT
	1680x1050	59.954	65.290	146.250	x	x	x	VESA CVT
	1920x2160	60	135.000	297.000	x	x	x	CEA-861-F, VIC 16, with vertical parameters doubled
	2560x1440	59.951	88.787	241.500	x	x	x	VESA CVT-R
	2560x1600	59.972	98.713	268.500	x	x	x	VESA CVT-R
	3840x2160	24	52.438	209.750	x	x	x	VESA CVT-R
	3840x2160	30	65.688	262.750	x	x	x	VESA CVT-R
	3840x2160	50	110.500	442.000	x		x	VESA CVT-R
3840x2160	60	133.313	533.250	x		x	VESA CVT-R	
Apple Mac	640x480	66.59			x	x	x	
	832x624	75.087	49.107	55.000	x	x	x	
	1024x768	59.278	48.193	64.000	x	x	x	
	1024x768	74.927	60.241	80.000	x	x	x	
	1152x870	75.062	68.681	100.000	x	x	x	
SDTV	480i	60			x	x	x	SMPTE 125M, CEA-861-F Formats 6 & 7
	576i	50			x	x	x	ITU-R BT.601, CEA-861-F Formats 21 & 22
EDTV	480p	60	31.469	27.000	x	x	x	ITU-R BT.1358, CEA-861-F Format 17 & 18
	576p	50	31.250	27.000	x	x	x	SMPTE 125M, CEA-861-F Format 6 & 7

Signal Type	Resolution	Frame rate (Hz)	Line Rate (kHz)	Pixel Rate (MHz)	HDMI 1-2	HDMI 3-4	DisplayPort	References
HDTV	1080i	50	28.125	74.500	x	x	x	SMPTE 274M, CEA-861-F Format 20
	1080i	60	33.750	74.250	x	x	x	SMPTE 274M, CEA-861-F Format 5
	720p	50	37.500	74.250	x	x	x	SMPTE 296M, CEA-861-F Format 19
	720p	60	45.000	74.250	x	x	x	SMPTE 296M, CEA-861-F Format 4
	1080p	24	27.000	74.250	x	x	x	SMPTE 274M, CEA-861-F Format 32
	1080p	25	28.125	74.250	x	x	x	SMPTE 274M, CEA-861-F Format 33
	1080p	30	33.750	74.250	x	x	x	SMPTE 274M, CEA-861-F Format 34
	1080p	50	56.250	148.500	x	x	x	SMPTE 274M, CEA-861-F Format 31
	1080p	60	67.500	148.500	x	x	x	SMPTE 274M, CEA-861-F Format 16
UHDTV	3840x2160	24	54.000	297.000	x	x	x	CEA-861-F Format 93, HDMI 1.4b VIC 1
	3840x2160	25	56.250	297.000	x	x	x	CEA-861-F Format 94, HDMI 1.4b VIC 2
	3840x2160	30	67.500	297.000	x	x	x	CEA-861-F Format 95, HDMI 1.4b VIC 3
	3840x2160	50	67.500	297.000	x			CEA-861-F Format 96, 4:2:0 sub-sampling
	3840x2160	50	135.000	594.000	x		x	CEA-861-F Format 96
	3840x2160	60	67.500	297.000	x			CEA-861-F Format 97, 4:2:0 sub-sampling
	3840x2160	60	135.000	594.000	x		x	CEA-861-F Format 97

# Color Subsampling Support

Video Timing	Input	RGB 4:4:4 Supported	YUV 4:4:4 Supported	YUV 4:2:2 Supported	YUV 4:2:0 Supported
4K @ 50/60 Hz	DP	x	x	x	
4K @ 50/60 Hz	HDMI 1-2	x	x	x	x
4K @ 50/60 Hz	HDMI 3-4				
All Other Supported Timings	Any	x	x	x	



# Specifications

Item	QE7550 QE7550T	QE8650 QE8650T	QE9850 QE9850T
<b>LCD Panel</b>			
Resolution	3840 x 2160		
Aspect Ratio	16:9		
Screen Size	75"	86"	98"
Orientation	Landscape/Portrait		
Brightness (Typ.)	500 cd/m <sup>2</sup>	500 cd/m <sup>2</sup>	400 cd/m <sup>2</sup>
Contrast Ratio (local dimming enabled)	20,000:1		
Contrast Ratio (local dimming disabled)	1200:1	1200:1	1300:1
Viewing Angle (Typ.)	178°		
Response Time (Typ.)	6ms	8ms	8ms
Color Gamut	72% NTSC		
Display Color	1.07 billion (10-bit depth)		
<b>Connectivity</b>			
Standard Inputs	DisplayPort 1.2, HDMI 2.0 x 2, HDMI 1.4 x 2, ContentSmart		
Audio Output	Line out, S/PDIF		
Control and Monitoring	LAN RJ45, RS232 In, IR, Keypad		
<b>Mechanical</b>			
Display Dimensions	Standard: 66.2" x 37.7" x 3.24" (1680.3 mm x 958.7 mm x 82.3 mm)  Touch: 67.4" x 39" x 3.64" (1711.4 mm x 990.3 mm x 92.4 mm)	Standard: 75.8" x 43.2" x 3.3" (1926.2 mm x 1097.2 mm x 83.7 mm)  Touch: 77" x 44.4" x 3.73" (1957 mm x 1128 mm x 94.7 mm)	Standard: 86.3" x 49.1" x 3.83" (2191.8 mm x 1246.8 mm x 97.3 mm)  Touch: 87.4" x 50.2" x 4.37" (2219.8 mm x 1275.4 mm x 110.9 mm)
Bezel Width	Standard: 0.60" (15.3 mm) left/right; 0.61" (15.4 mm) top/bottom  Touch: 1.22" (30.9 mm) left/right; 1.23" (31.2 mm) top/bottom	Standard: 0.61" (15.6 mm) left/right; 0.62" (15.7 mm) top/bottom  Touch: 1.2" (31.0mm) left/right, top/bottom	Standard: 0.63" (16.0 mm) left/right; 0.62" (15.7 mm) top/bottom  Touch: 1.2" (31.0mm) left/right, top/bottom

Item	QE7550 QE7550T	QE8650 QE8650T	QE9850 QE9850T
Display Weight	Standard: 115 lbs (52 kg)  Touch: 138 lbs (63 kg)	Standard: 126 lbs (57 kg)  Touch: 158 lbs (72 kg)	Standard: 187 lbs (85 kg)  Touch: 243 lbs (110 kg)
Mounting	VESA 600 mm x 400 mm		
Fanless	Yes		
Speakers	10W x 2 built-in		
<b>Usage</b>			
Recommended Usage	24x7		
Backlight	E-LED	E-LED	D-LED
Backlight Life	30,000 hours min		
<b>Power Source</b>			
Power Consumption (Typ.)	195W	165W	410W
BTU/hr (Typ.)	195W x 3.42 BTU = 667 BTU/hr	165W x 3.42 BTU = 564 BTU/hr	410W x 3.42 BTU = 1402 BTU/hr
Standby Power Consumption	<1W		
Input Voltage / Frequency	AC 100-240V 50-60 Hz		
<b>Environment</b>			
Storage Temperature	Min -4°F ~ Max 140°F (-20°C ~ 60°C)		
Operating Temperature	Min 32°F ~ Max 95°F (0-35°C) at up to 1500 m Min 32°F ~ Max 86°F (0-30°C) at up to 3000 m		
Humidity	20-85% RH		
Approvals	FCC Class A, cTUVus, CE		

## Embedded Planar ContentSmart Specifications

Item	Specification
Video format support	H.264/AVC up to 2160p @24fps (3840x2160) MPEG-4 up to 1080p @60fps (1920x1080) MPEG-2 up to 1080p @24fps (1920x1080) MPEG-1 up to 1080p @60fps (1920x1080) VC-1 up to 1080p @30fps (1920x1080) H.265/HEVC: 4k @60fps (4096x2160) up to 50Mbps bit rate
Image format support	JPEG PNG
Audio codec support	MPEG Audio (MP3)
Dynamic content	W3C HTML5 (HTML, CSS, JavaScript) W3C SMIL 3.0 instructions (sub-set)
Physical I/O connectors	HDMI 2.0 USB 2.0 x 2 RJ45 Ethernet port (Giga LAN) microSD card slot LED: Power/Status
Local storage	8 GB eMMC microSD card expansion slot

# Dimensions

QE7550

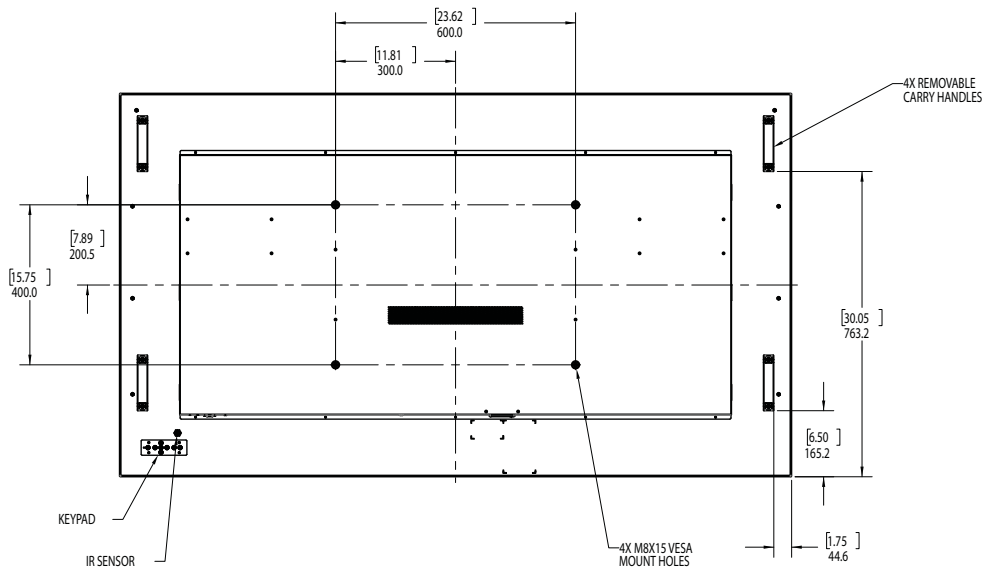
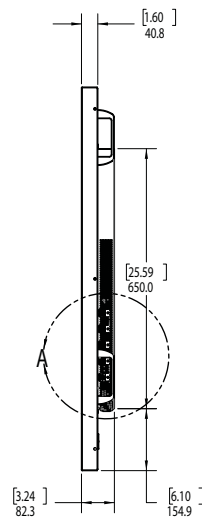
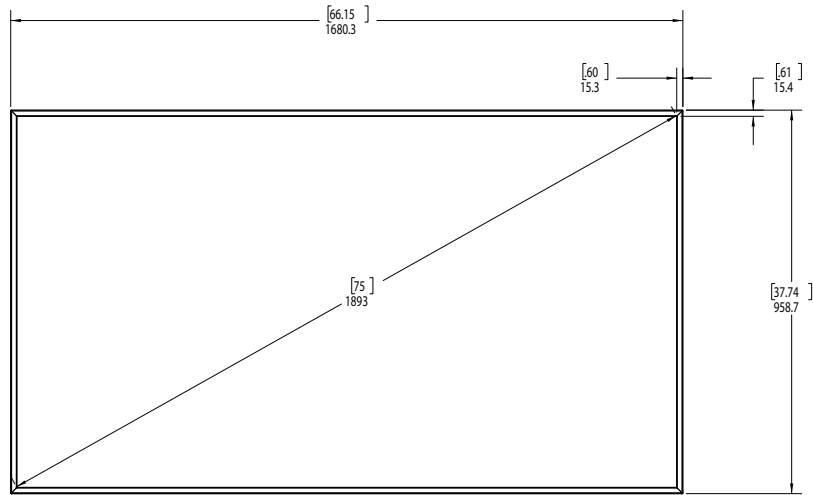
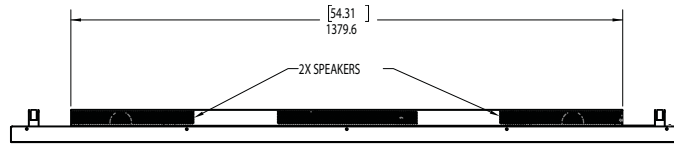

# QE7550 Touch

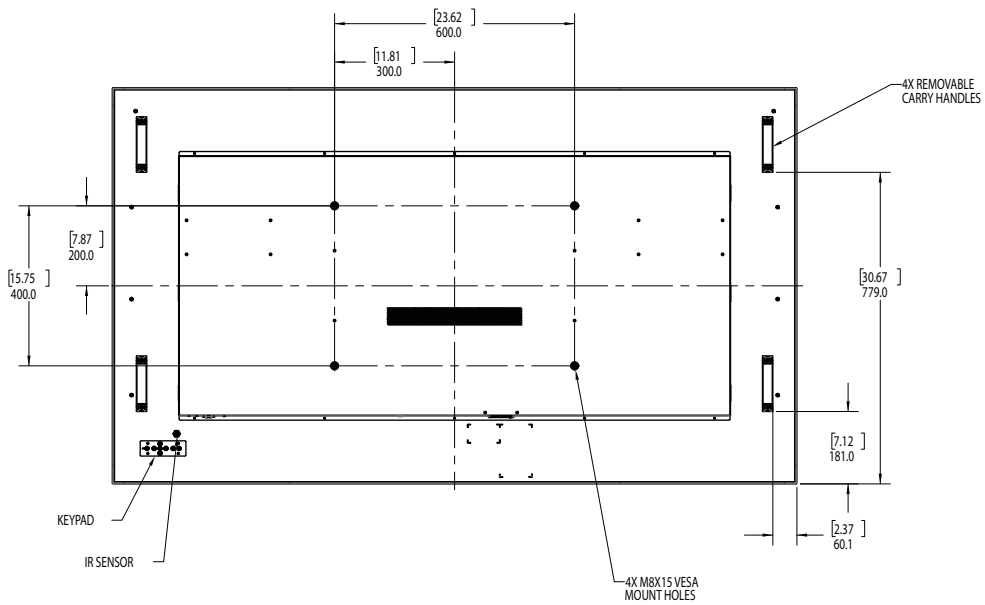
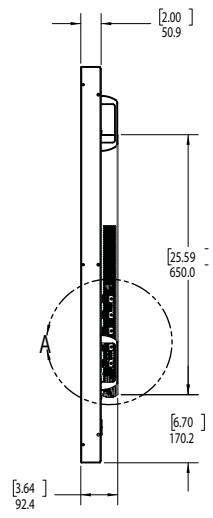
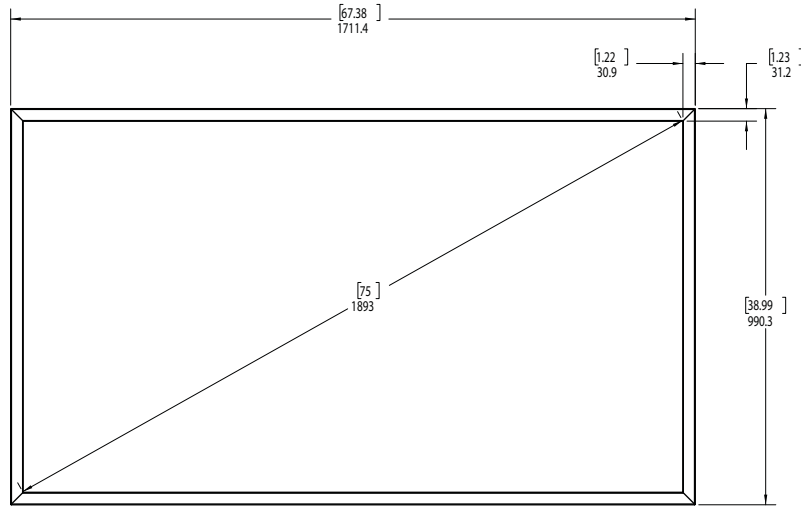
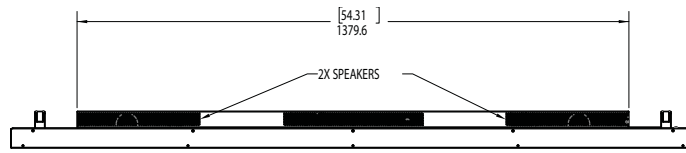

# QE8650

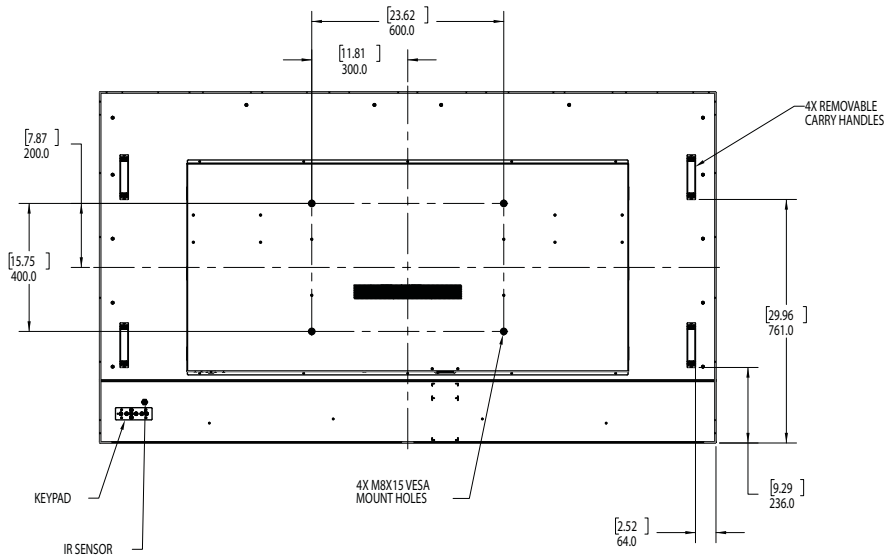
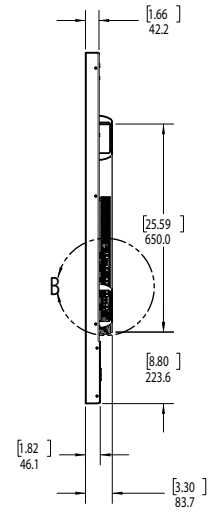
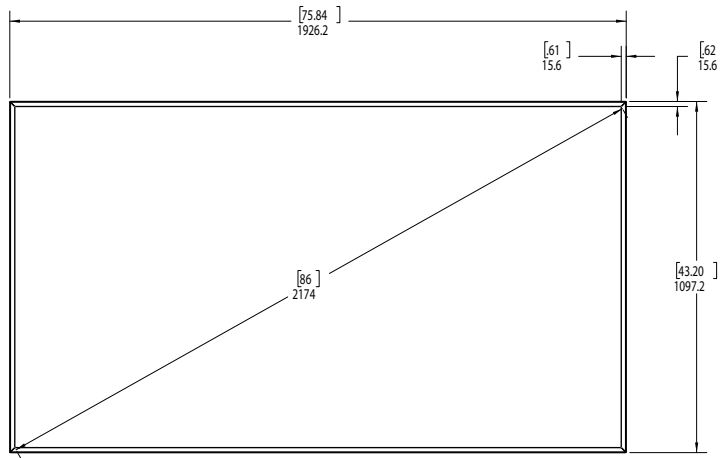
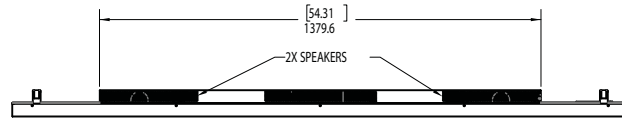

# QE8650 Touch

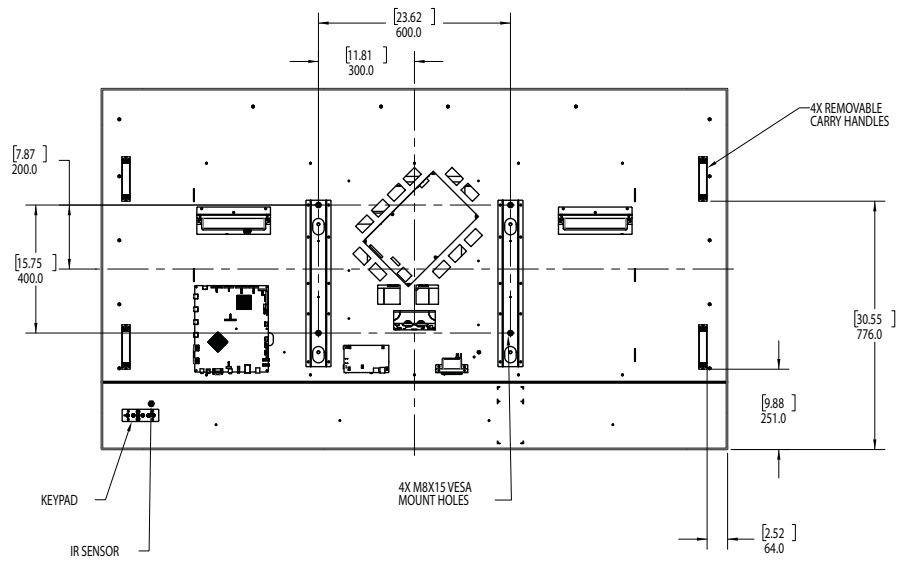
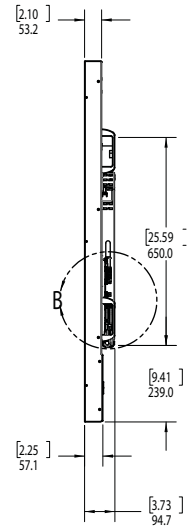
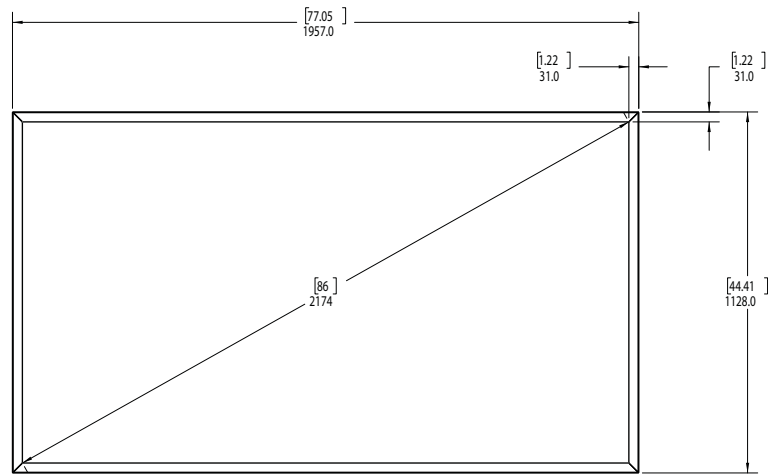
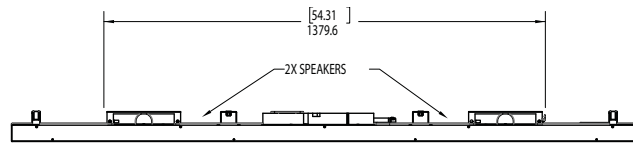

# QE9850

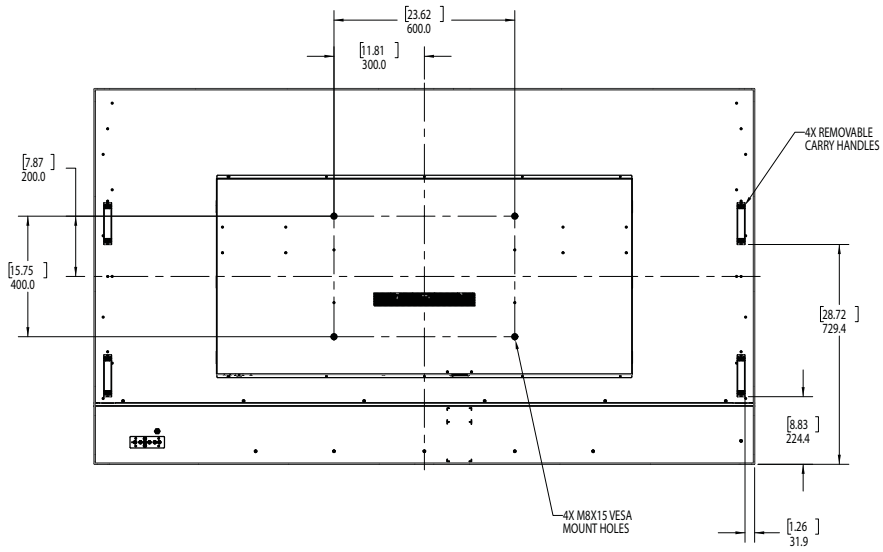
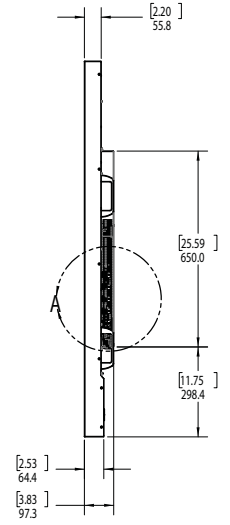
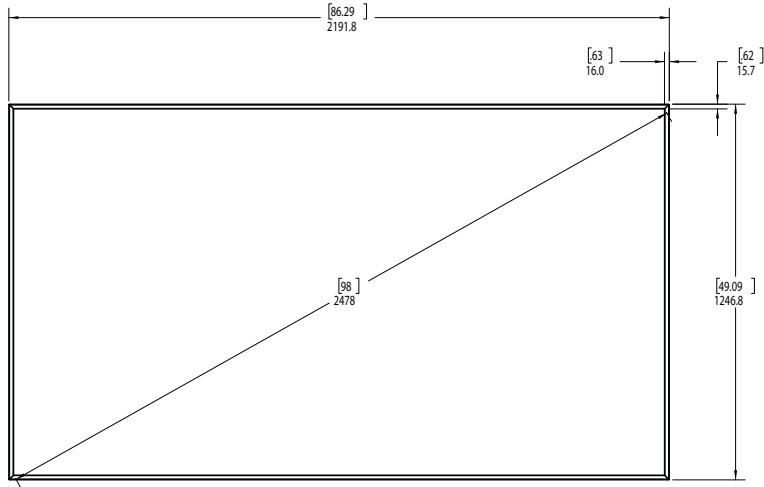
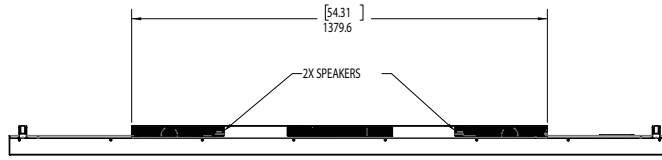



# QE9850 Touch

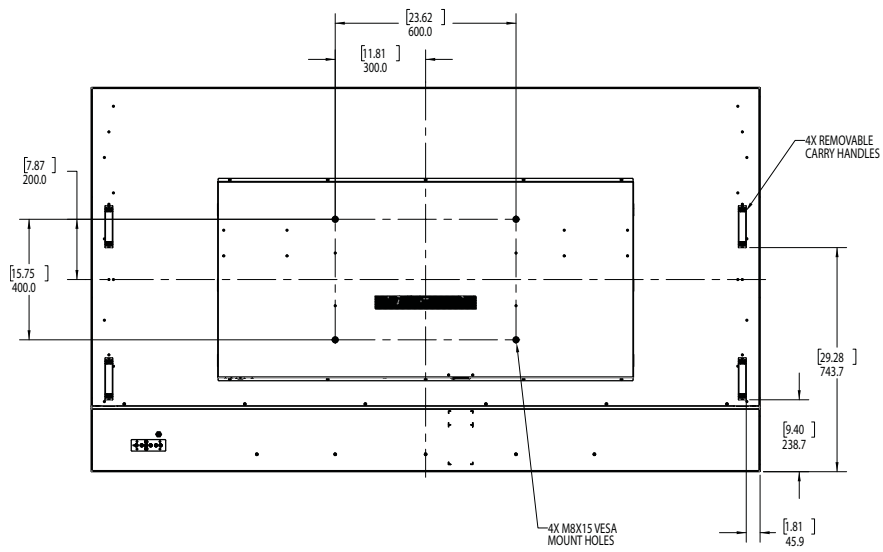
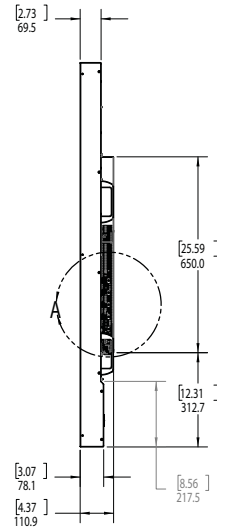
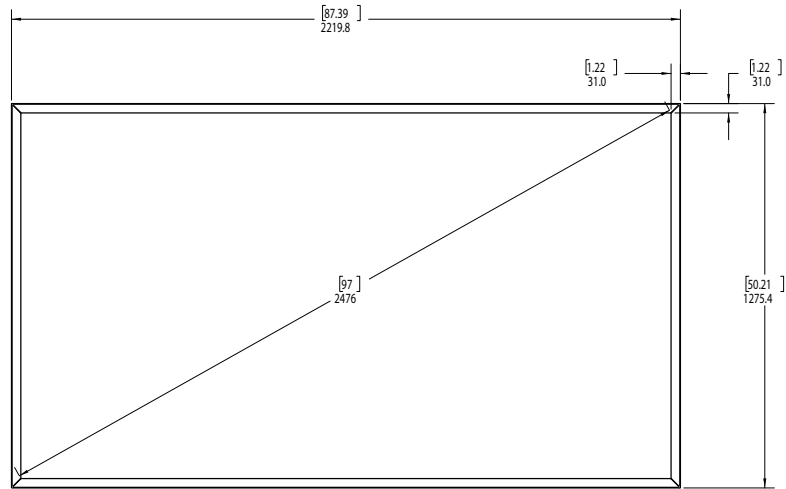
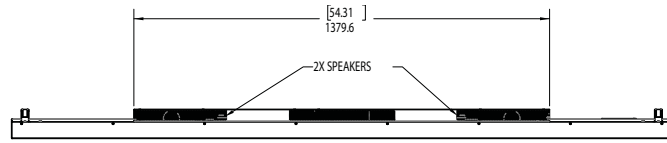

# Troubleshooting During Installation

This section includes troubleshooting information about different issues you may encounter during the installation process or after your display has been running for some time. If you are not able to solve your issue in this section, please contact Planar’s Technical Support team for assistance.

## Error Codes

To see the last 50 errors that have occurred, select the Error Log tab in the OSD (MAIN MENU > INFORMATION > ERROR LOG), as shown below.

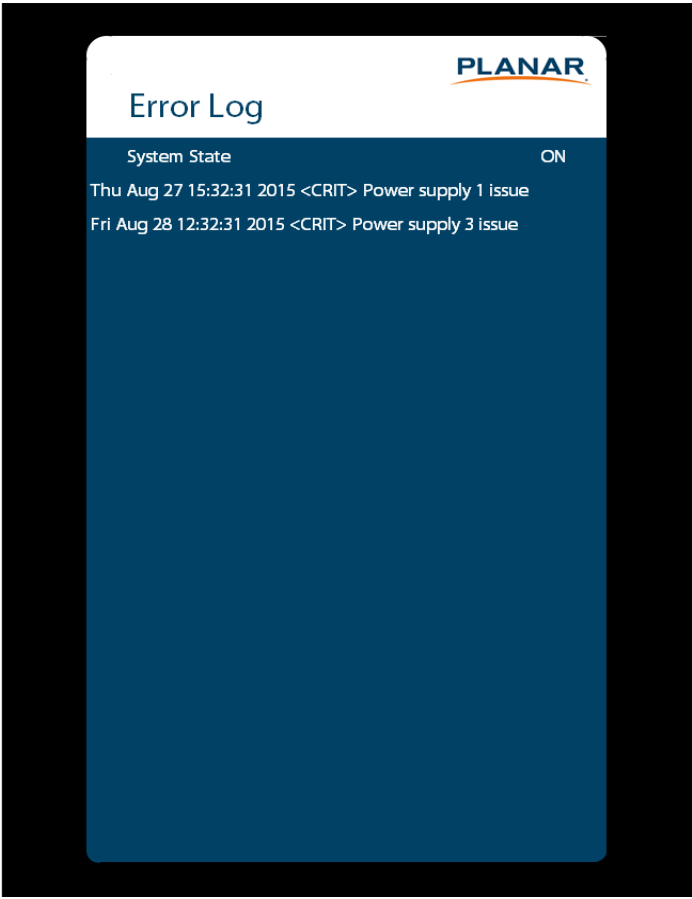

## Symptoms, Possible Causes and Solutions

Below are different symptoms that you might encounter as you install your Planar QE Series display. First look at the different symptoms to see if you can find your issue. And then look at the possible cause and try the suggested solution(s). If you still are not able to resolve your issue, please contact Planar's Technical Support Department.

### Symptom: Can't Get PC to Output 4K @ 24/30/60 Hz

#### Solution

Make sure that your graphics card can support a 4K output. See "Supported Graphics Cards" on page 12 for a list of the current graphics cards that Planar supports for the Planar QE Series displays.

#### Solution

Confirm that you are using a DisplayPort output. You can't use a DisplayPort-to-HDMI adapter to output 4K content.

#### Solution

Make sure you are using a high-speed HDMI cable. Standard HDMI cables might work but are not guaranteed.

#### Solution

Verify that the selected **EDID Type** setting in the OSD is **4K60** or **4K30**. If you change the EDID setting, you may need to disconnect and reconnect the cable.

#### Solution

If you are trying to use 4K @ 60 Hz on HDMI, the display must be connected to HDMI 1 or HDMI 2.

#### Solution

If you are trying to display 4K @ 60 Hz on HDMI 1 or HDMI 2, the Multi-Source View setting must be Single.

## Symptom: Can't Get PC to Output 4K @ 24/30/60 Hz

### Possible Cause

The connector overmold is too large, which can cause the pins not to contact properly on some cards.

### Solution

If using DisplayPort, make sure the connector overmold isn't too large.



## Symptom: Can't Select ContentSmart or HDMI 1

### Solution

The ContentSmart and HDMI sources cannot be viewed at the same time. If your Multi-Source View setting is not Single, and you select ContentSmart in a zone, any zones that are showing HDMI 1 will automatically change to ContentSmart. Conversely, if you select HDMI 1 in a zone, any zones that are currently showing ContentSmart will automatically change to HDMI 1.

## Symptom: IR Isn't Working Properly

### Possible Cause

The wired IR module may not be fully connected.

### Solution

Make sure the IR is fully connected by pressing hard to ensure it is inserted as far as possible.

### Possible Cause

The wired IR module cable is not being used.

### Solution

Make sure that the wired IR module cable is being used.



## Embedded Planar ContentSmart FAQ

### What video format can I play?

Video files encoded in MPEG-4 AVC up to 1920x1080 resolution at 10 Mbps bitrates or HEVC H.265 up to 20 Mbps bitrates should play fine. If a certain video does not play as scheduled, or if it plays poorly, contact Planar Support.

### What should I do if I forgot my password?

Perform a factory reset.

Use the SW reset button located next to the USB connectors to restore factory settings. This will also clear the player's password.

### How do I manage the playback of contents?

The media player is designed to be interoperable with leading third-party management software solutions or via SMIL open standard commands.

### Can the player display Flash or Microsoft PowerPoint presentations?

The player features limited Microsoft PowerPoint support, but not Flash support.

While PCs can play many formats with varying degrees of success, RISC-based media players are designed to reliably play specific video formats (see spec for details).

While Microsoft PowerPoint native files cannot play directly on a RISC-based player, the file can be converted into an image format to be played as an image slideshow.

### Why won't some media files play properly?

The video data bit-rate used may have exceeded the recommended bit rate.

The video data bit-rate is the amount of video or audio data used per second to store or play the contents, usually expressed in Mbps (mega-bits per second). Video encoded with excessive bit-rates will not playback smoothly in the media player, likely due to storage I/O bottleneck.

Visit <http://www.planar.com/contentsmart> for compatible media format presets.

### Some JPEG images cannot be played in the media player.

The media player works best with 4K UHD (3840 x 2160) images. Playback of native images directly from the camera may result in an image being displayed incorrectly or not at all.

### Does the media player support video streaming?

No. Media players play files from local storage and do not support real-time video streaming over the network. This delivers an optimum viewing experience free of playback quality issues such as stuttering, blocking or blue-screens.

### The player is not playing. What should I do?

Play list errors and scheduling issues are two major causes of playback problems. To determine if the problem is caused by a bad playlist, delete the playlist and restart the player. The player should loop through all media files, indicating a fault with the playlist.

If the playback is scheduled to play at specific time, check to see if the device is set to the right time zone on the world clock. If nothing appears wrong, the time zone setting is often the reason the program is not played.

### The video is playing but I can't hear any sound, what should I do?

Check volume (mute) settings on monitor.

# Accessing Planar's Technical Support Website

Visit <http://www.planar.com/support> for the following support documents and resources:

- User Manual
- RS232 User Manual
- Touch screen drivers
- Standard warranties
- Planar support hotline number and email





# Index

---

## A

adjusting volume, 21  
advanced settings menu, 30  
audio menu, 28  
avoiding temporary image retention, 4

---

## C

cleaning the display, 6  
codes, error, 100  
color subsampling, 90  
connecting  
    touch screen, 47  
control, external, 86

---

## D

dimensions, 94  
display  
    installing, 11

---

## E

error codes, 100  
external control, 86

---

## I

image adjust menu, 25  
information menu, 44  
input source  
    selecting, 21  
inputs and view menu, 23  
installation  
    of LCD, 11  
    safety precautions, 3  
introduction, 1  
IR codes, using, 17  
IR commands  
    for Planar QE, 17

    protocol, 17  
IR not working, 103

---

## L

LCD  
    installation, 11  
locking, 19

---

## M

menus  
    advanced settings, 30  
    audio, 28  
    image adjust, 25  
    information, 44  
    inputs and views, 23  
    using, 22

---

## N

navigating menus, 22  
normal usage guidelines, 5

---

## O

osd menus, 19, 22  
    unlocking, 19

---

## P

package contents, 7  
Planar QE display  
    troubleshooting via error codes, 100

---

## R

recommended usage, 4  
remote control  
    using, 16

## S

- safety
    - during installation, 3
    - information, 2
    - precautions, 2
    - precautions during use, 4
  - selecting input source, 21
  - service plans, ii
  - signal compatibility, 87
  - specifications, 91
  - subsampling
    - color, 90
  - supported timings, 87
- 

## T

- temporary image retention
    - avoiding, 4
    - definition, 4
  - timings, 87
  - TIR *see temporary image retention*
  - touchscreen
    - using the touchscreen, 47
  - troubleshooting, 100
    - during installation, 100
    - error codes in Planar QE, 100
    - symptoms, 101
  - turning off the displays, 20
  - turning on the displays, 20
- 

## U

- using the remote, 16
- 

## V

- volume, 21
- 

## W

- warranty
  - information, ii

Planar, a Leyard company

Customer Service

24x7 Online Technical Support: [www.planar.com/support](http://www.planar.com/support)

1195 NW Compton Drive

Beaverton, OR 97006-1992

Tel: 1-866-PLANAR1 (866-752-6271), +1 503-748-5899 outside the United States

Hours: 24 hours a day, 7 days a week

© 01/2017 Planar, a Leyard company

Planar is a registered trademark of Planar, a Leyard company. Other brands and names are the property of their respective owners. Technical information in this document is subject to change without notice.

020-1320-00A