

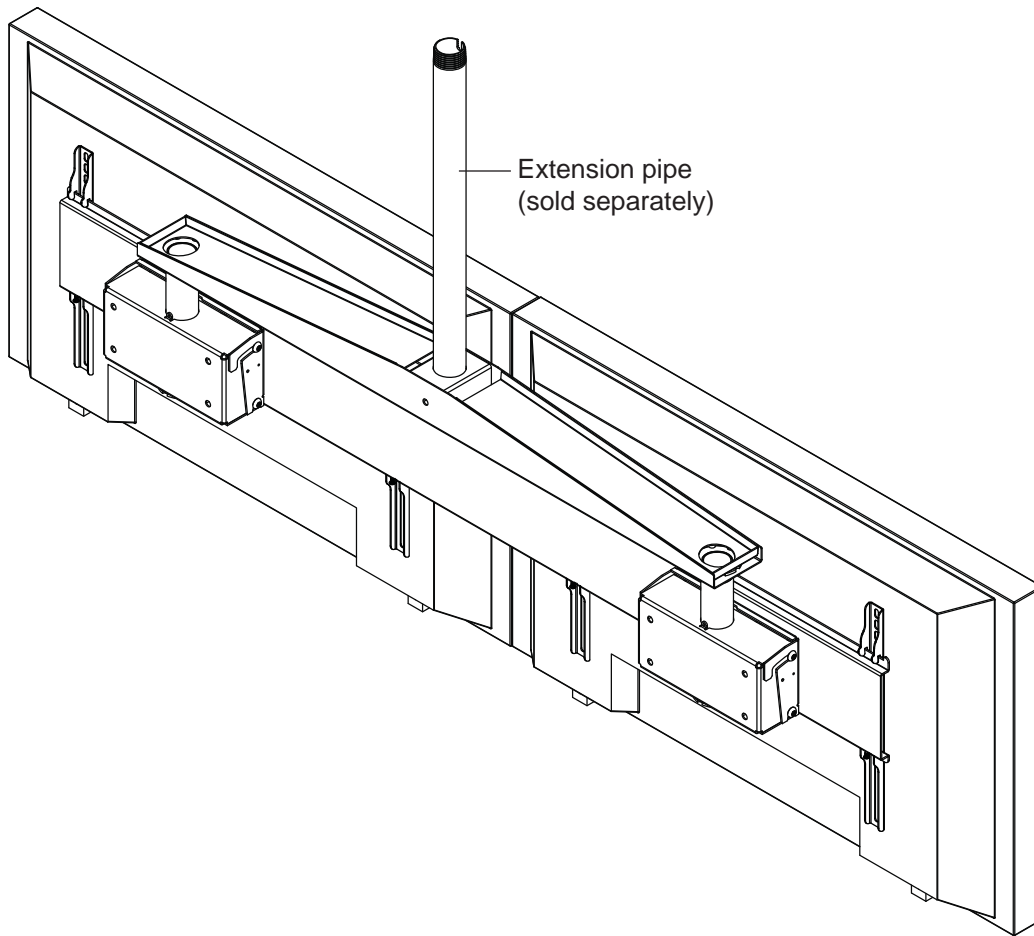

Installation and Assembly: Dual Display Ceiling Mount System

Models: DST940



Max Load Capacity: 150 lb (68 kg)

ISSUED: 08-10-09 SHEET #: 139-9011-3 08-18-14

NOTE: Read entire instruction sheet before you start installation and assembly.

⚠ WARNING

- Do not begin to install your Peerless product until you have read and understood the instructions and warnings contained in this Installation Sheet. If you have any questions regarding any of the instructions or warnings, for US customers please call Peerless customer care at 1-800-865-2112, for all international customers, please contact your local distributor.
- This product should only be installed by someone of good mechanical aptitude, has experience with basic building construction, and fully understands these instructions.
- Make sure that the supporting surface will safely support the combined load of the equipment and all attached hardware and components.
- Never exceed the Maximum Load Capacity. See page one.
- Always use an assistant or mechanical lifting equipment to safely lift and position equipment.
- Tighten screws firmly, but do not overtighten. Overtightening can damage the items, greatly reducing their holding power.
- This product is intended for indoor use only. Use of this product outdoors could lead to product failure and personal injury.

Tools Needed for Assembly

- phillips screwdriver
- drill
- 3/8" drill bit

Table of Contents

Parts List.....	3
Attaching Dual Cross Support to Extension Pipe	5
Attaching Extension Columns to Dual Cross Support	5
Attaching Solid•Point™ Column Mounts to Extension Columns.....	6
(Optional) Attaching DSX750 to Ceiling Arm Boxes	7
Attaching Adapter Plate and Tilt Brackets to Ceiling Arm Boxes	7
Attaching Adapter Brackets to Screens.....	8-9
Attaching Adapter Brackets to Adapter Plate.....	10

Before you begin, make sure all parts shown are included with your product.
Parts may appear slightly different than illustrated.

Parts List			
Description	Qty	Part #	
A 6" extension column	2	128-1094	
B dual cross support	1	139-1015	
C 4.5" hex bolt	1	520-9548	
D 3/8-16 nylock nut	1	530-9310	
E retaining collar	3	1800-375	
F extension pipe fiber washer	1	540-9431	
G M5 x 10 mm screw	1	520-9250	
H ceiling arm box	2	124-1974	
I tilt bracket	2	200-1552	
J M5 x 10 mm penta-pin screw	8	505-9010	
K extension column fiber washer	2	540-9432	
L M10 x 15 mm penta-pin screw	16	520-9263	
M M10 x 2" penta-pin tool	2	520-9260	
N M5 x 1" penta-pin tool	2	520-9249	
P adapter bracket	4	202-1655	
Q adapter plate	1	124-1280	
R 4 mm allen wrench	1	560-9646	

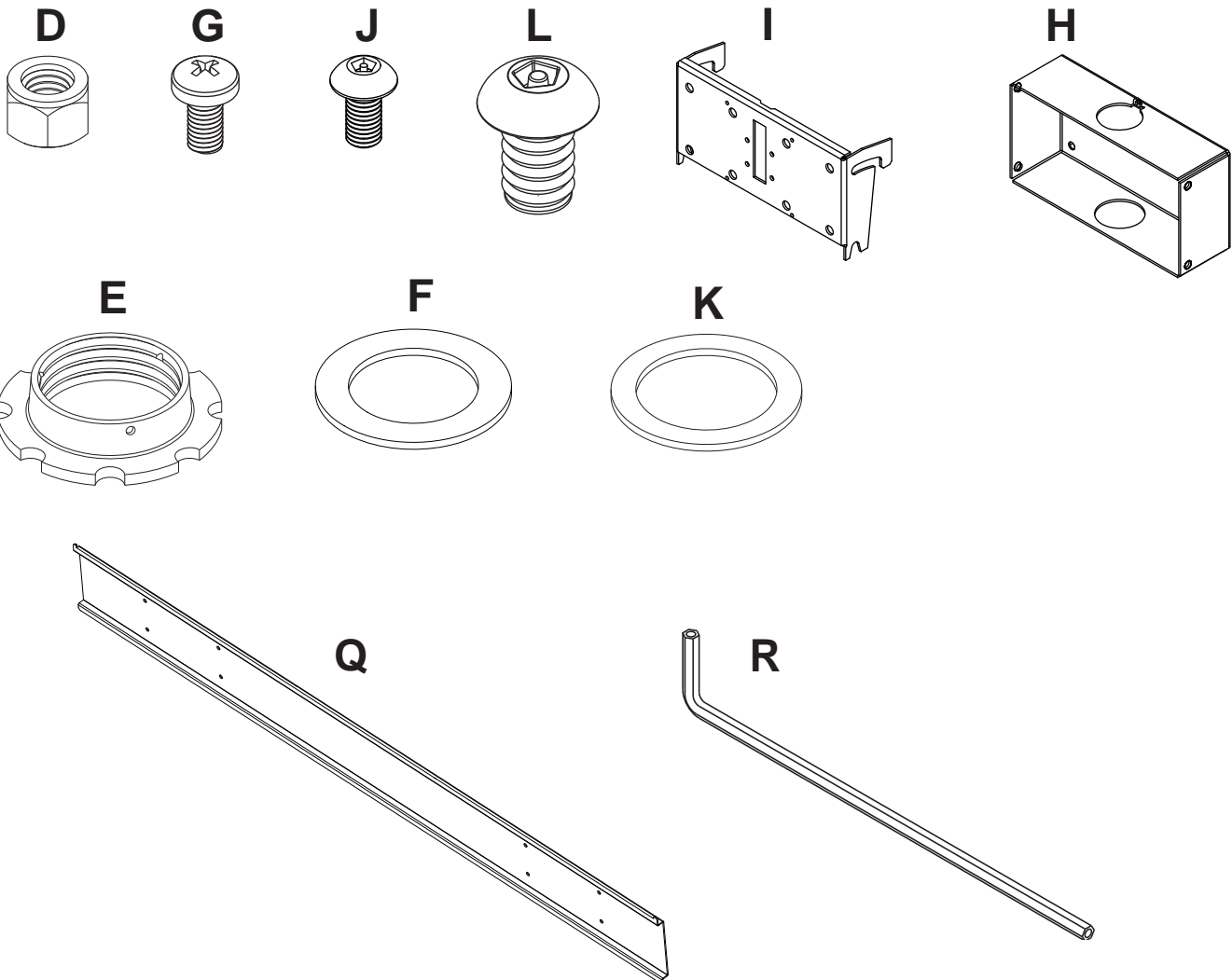
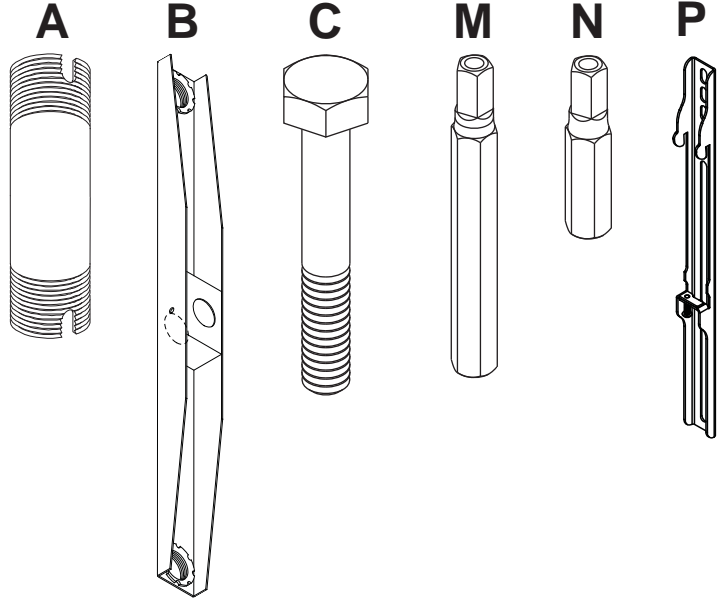

Security Adapter Bracket Fasteners

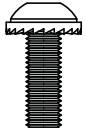

M4 x 12 mm (12)
510-1079

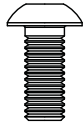

M5 x 12 mm (8)
520-1064

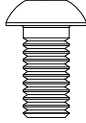

M6 x 12 mm (8)
520-1050

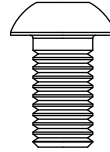

M8 x 15 mm (12)
520-1068



M6 x 20 mm (8)
520-9554

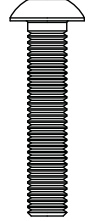

M5 x 25 mm (8)
520-1122



M4 x 25 mm (8)
510-1082

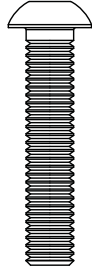

M6 x 30 mm (8)
520-1067

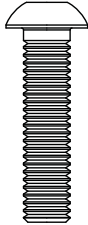

M6 x 25 mm (8)
520-1211

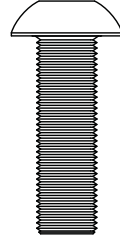

M8 x 25 mm (8)
520-1101

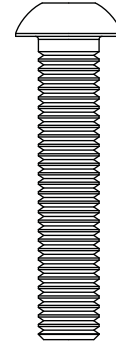

M8 x 40 mm (8)
520-1152

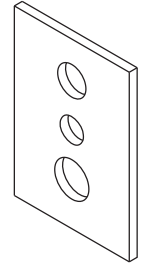

multi-washer (12)
580-1036

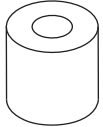

I.D. .22" (5.6 mm) (8)
540-1057

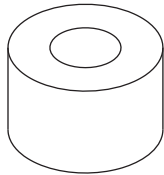

I.D. .34" (8.7 mm) (8)
540-1059

Attaching Dual Cross Support To Extension Pipe

- Slide dual cross support (**B**) onto end of extension pipe (sold separately) followed by extension pipe fiber washer (**F**) and retaining collar (**E**). Tighten retaining collar so that thread is securely engaged.

Align one small hole of retaining collar (**E**) with slot of the extension pipe as shown in figure 1.2. Insert and tighten one M5 x 10 mm phillips screw (**G**) through hole of retaining collar into slot of extension pipe.

Rotate dual cross support (**B**) to desired position. Drill 3/8" dia. hole into extension pipe through hole of dual cross support (**B**). Lock into place with 3/8" bolt (**C**) and nylock nut (**D**) as shown in figure 1.1.

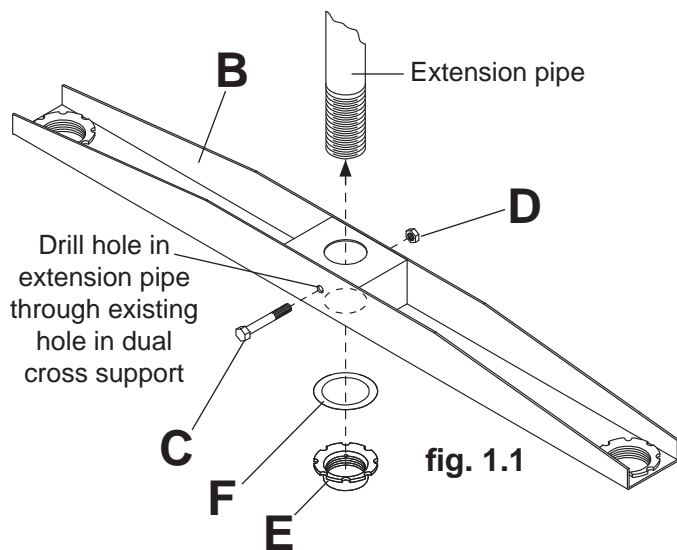

⚠ WARNING

- Installer must verify that the supporting surface will safely support four times the combined weight of all attached equipment and hardware.
- For safety, retaining collar must be locked to extension pipe with screw.

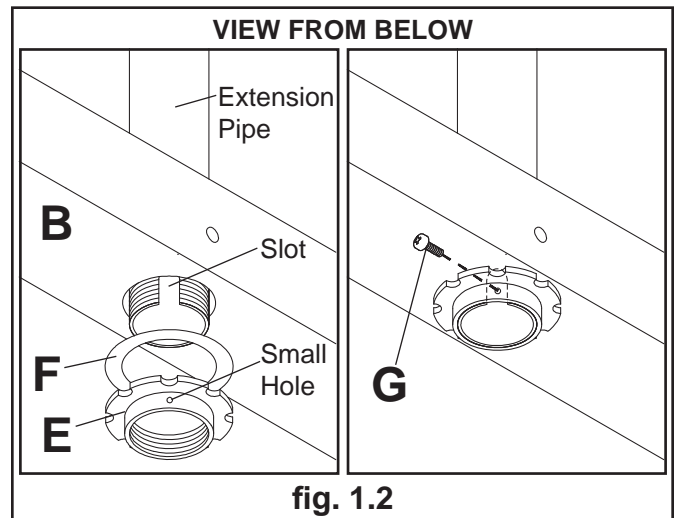

Attaching Extension Columns to Dual Cross Support

- Thread extension column (**A**) into bottom of threaded fitting on dual cross support (**B**) as shown. Tighten extension column so thread is securely engaged.

Align one small hole in the threaded fitting of dual cross support (**B**) with slot of extension column (**A**) as shown. Insert and tighten one M5 x 10 mm penta-pin screw (**J**) through the hole of threaded fitting and slot of extension column (**A**).

Use the M5 penta-pin tool (**N**) to tighten screw. Repeat step two to attach second extension column (**A**) to dual cross support (**B**).

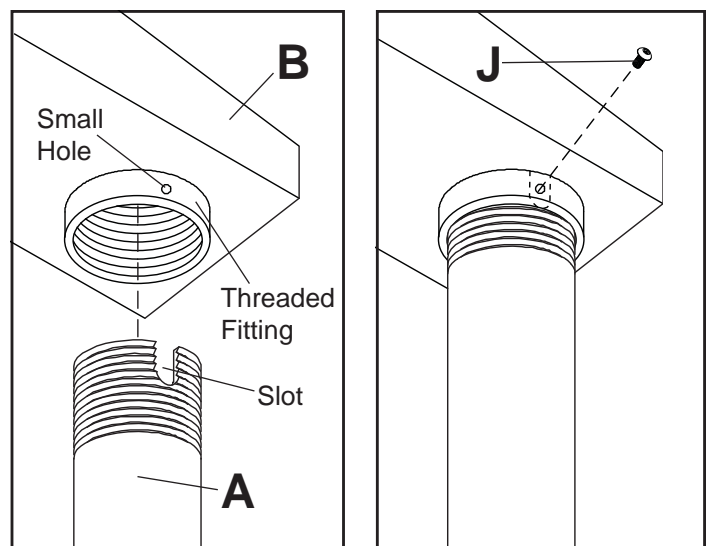

Attaching Solid•Point™ Column Mounts to Extension Columns

3 Insert four M10 x 15 mm penta-pin screws (**L**) into threaded holes on the sides of ceiling arm box (**H**) as shown in figure 3.1. Leave approximately 1/4" of exposed thread as shown in detail 1.

Slide ceiling arm box (**H**) onto end of extension column (**A**) followed by extension column fiber washer (**K**) and retaining collar (**E**) as shown in figure 3.2. Tighten retaining collar and align slot of extension column (**A**) with hole of retaining collar (**E**).

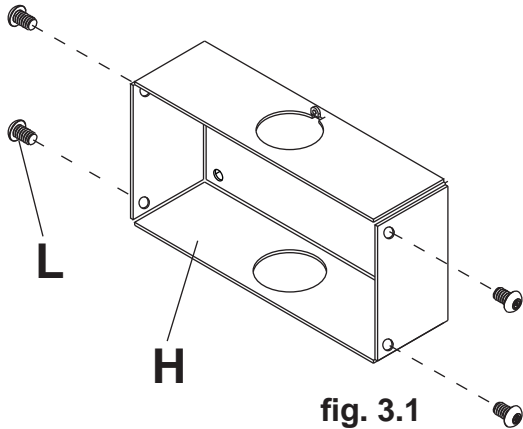
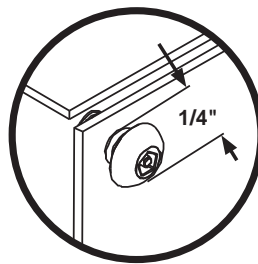

fig. 3.1



DETAIL 1

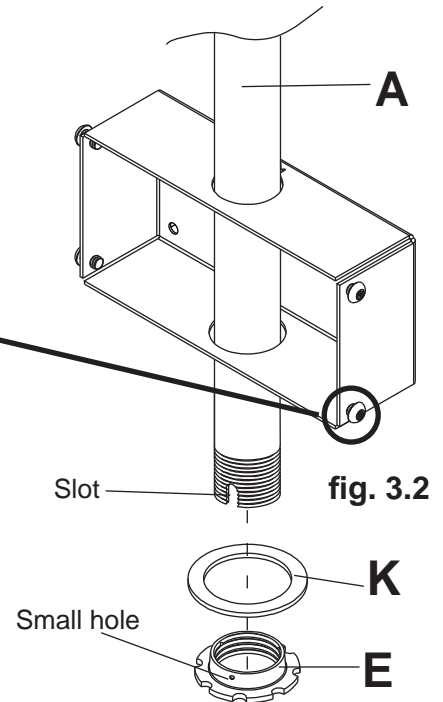

fig. 3.2

3-2 Insert and tighten one M5 x 10 mm penta-pin screw (**J**) through the hole of the retaining collar (**E**) and slot of extension column (**A**) as shown in figure 3.3.

Insert one M5 x 10 mm penta-pin screw (**J**) through the tab on the back of ceiling arm box (**H**) as shown in detail 2.

Use the M5 penta-pin tool (**N**) to tighten screws. Repeat step three to attach second ceiling arm box (**H**).

NOTE: Both ceiling arm boxes (**H**) must be at same height to attach adapter plate (**Q**) properly.

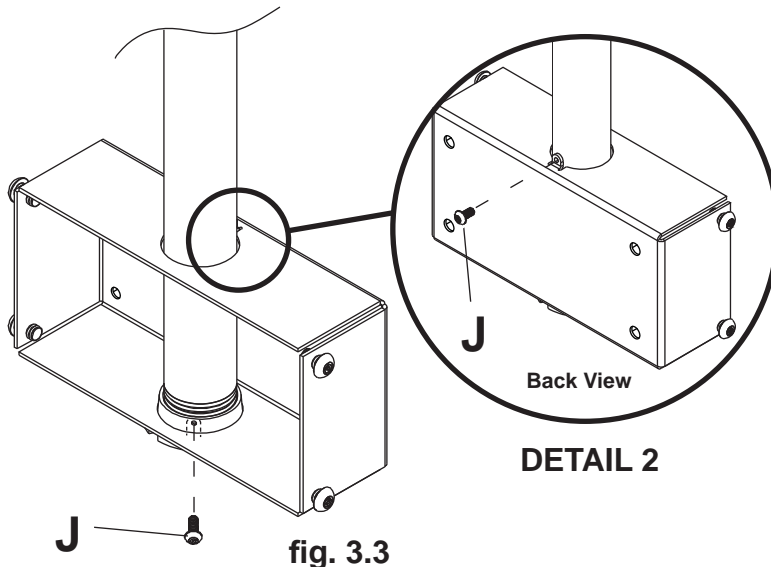
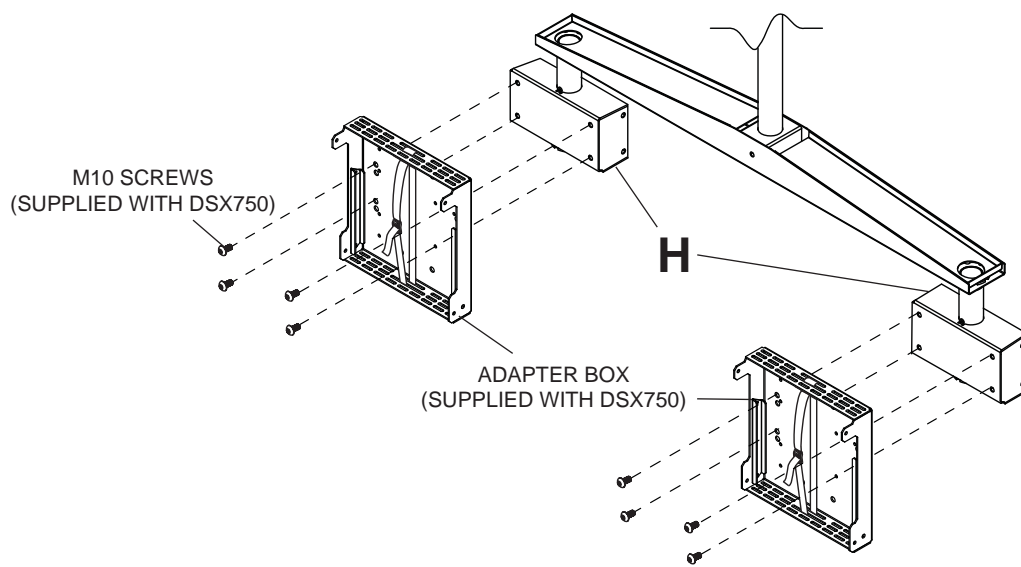

fig. 3.3

Attaching DSX750 To Ceiling Arm Boxes (Optional)

- 4 Attach two adapter box (supplied with DSX750) to ceiling arm box (H) using four M10 screws (supplied with DSX750) per box as shown below.
NOTE: Use DSX750 instructions to complete installation of adapter box (supplied with DSX750).



Attaching Adapter Plate And Tilt Brackets To Ceiling Arm Boxes

- 5 Attach two tilt brackets (I) to adapter plate (Q) using eight M10 x 15 mm penta-pin screws (L) and tighten with M10 penta-pin tool (M) as shown in figure 5.1. Hook tilt brackets onto screws of ceiling arm boxes (H) as shown in figure 5.2. Adjust tilt to the zero degree tilt position as shown in figure 5.3 and tighten eight M10 x 15 mm penta-pin screws (L) with M10 penta-pin tool (M).

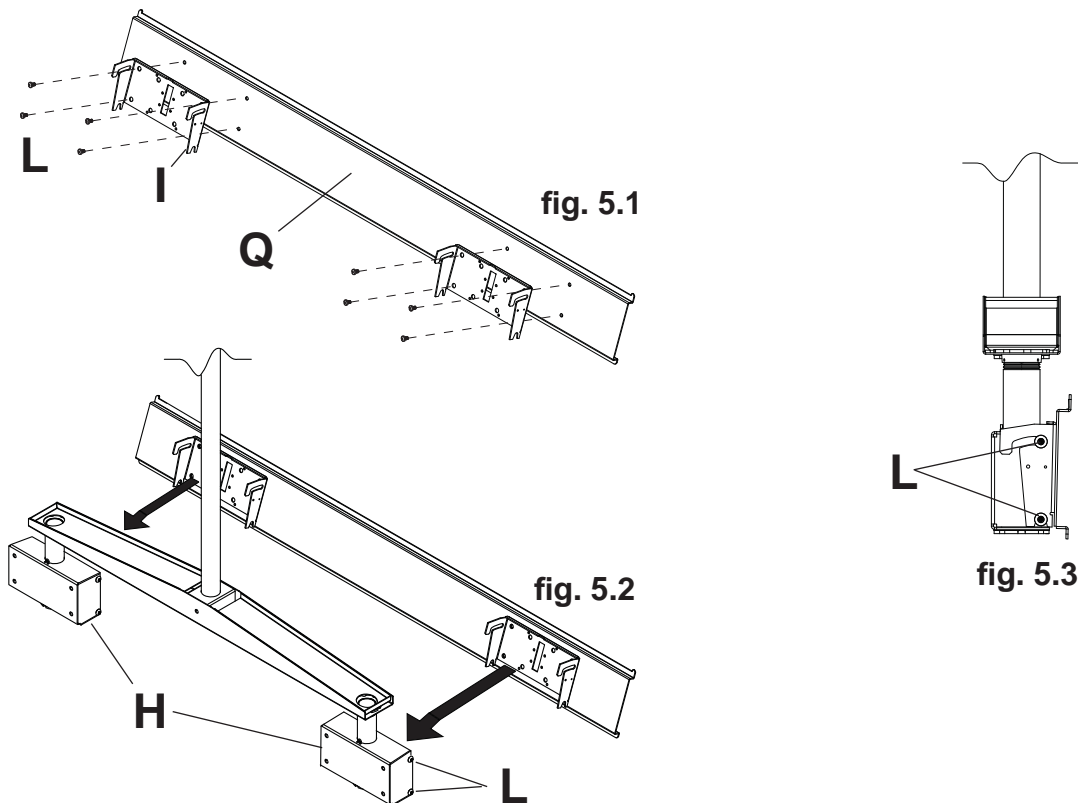

Installing Adapter Brackets

⚠ WARNING

- Tighten screws so adapter brackets are firmly attached. Do not tighten with excessive force. Overtightening can cause stress damage to screws, greatly reducing their holding power and possibly causing screw heads to become detached. Tighten to 40 in. • lb (4.5 N.M.) maximum torque.
- If screws don't get three complete turns in the screen inserts or if screws bottom out and bracket is still not tightly secured, damage may occur to screen or product may fail.

6 To prevent scratching the screen, set a cloth on a flat, level surface that will support the weight of the screen. Place screen face side down. If screen has knobs on the back, remove them to allow the adapter brackets to be attached. Place adapter brackets (**P**) on back of screen, align to holes, and center on back of screen as shown below. Attach the adapter brackets to the back of the screen using the appropriate combination of screws, multi-washers and spacers.

NOTE: Top and bottom holes on screen must always be used.

Verify that all holes are properly aligned, and then tighten screws using 4 mm allen wrench (**R**). Repeat step five to attach adapter brackets to second screen.

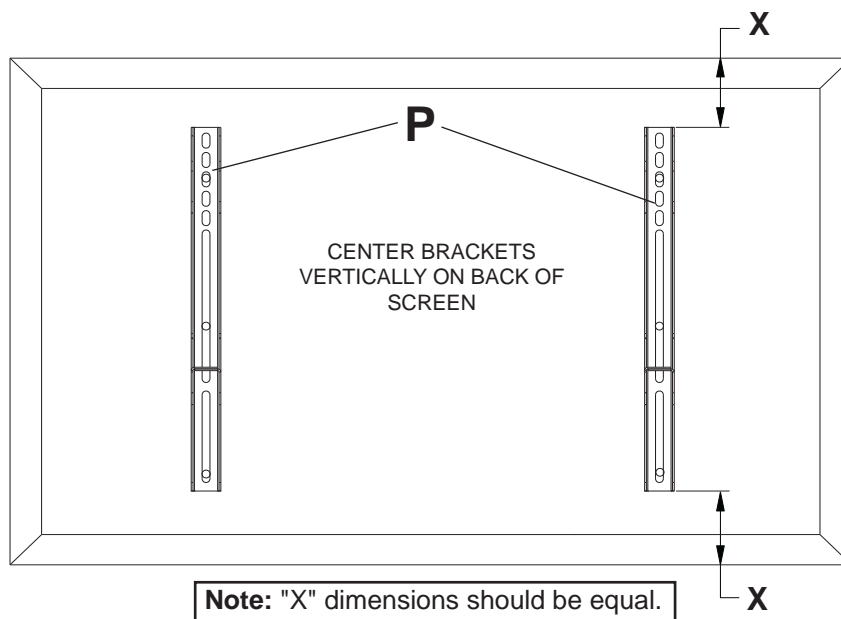

Notes:

- The number of fasteners used will vary, depending upon the type of screen.
- Multi-washers and spacers may not be used, depending upon the type of screen.
- Use the corresponding hole in the multi-washer that matches your screw size as shown.

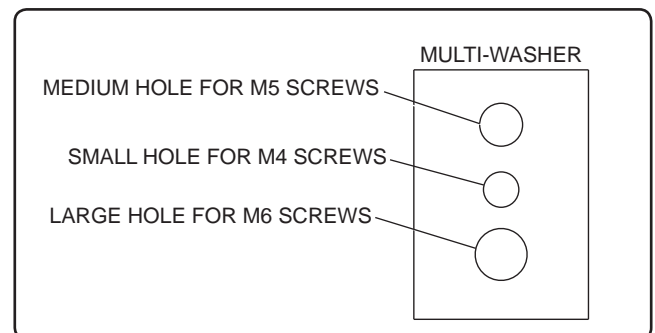

NOTE: For **flat back screens** proceed to step 6-1. For **bump-out or recessed back screen** skip to step 6-2

For Flat Back Screen

6-1 Refer to **Screen Compatibility Chart** to determine the proper fastener to use. Visit www.peerlessmounts.com/2 for a full screen compatibility chart for this mount.

Begin with the shortest length screw, hand thread through multi-washer and adapter bracket into screen as shown below. Screw must make at least three full turns into the mounting hole and fit snug into place. Do not over tighten. If screw cannot make three full turns into the screen, select a longer length screw from the baffled fastener pack. Repeat for remaining mounting holes, level brackets and tighten screws.

NOTE: Spacers may not be used, depending upon the type of screen.

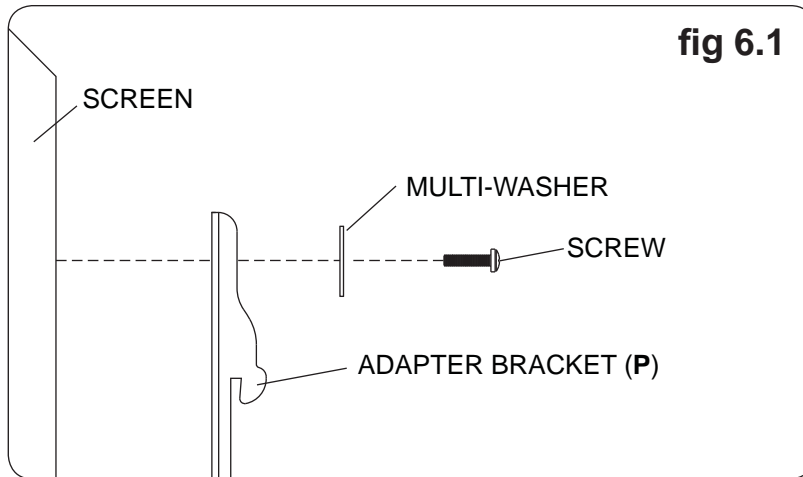

If you have any questions, please call Peerless customer care at **1-800-865-2112**.

For Bump-out or Recessed Back Screen

6-2 Refer to **Screen Compatibility Chart** to determine the proper fastener to use. Visit www.peerlessmounts.com/2 for a full screen compatibility chart for this mount.

Begin with longer length screw, hand thread through multi-washer, adapter bracket and spacer in that order into screen as shown below. Screw must make at least three full turns into the mounting hole and fit snug into place. Do not over tighten. If screw cannot make three full turns into the screen, select a longer length screw from the baffled fastener pack. Repeat for remaining mounting holes, level brackets and tighten screws.

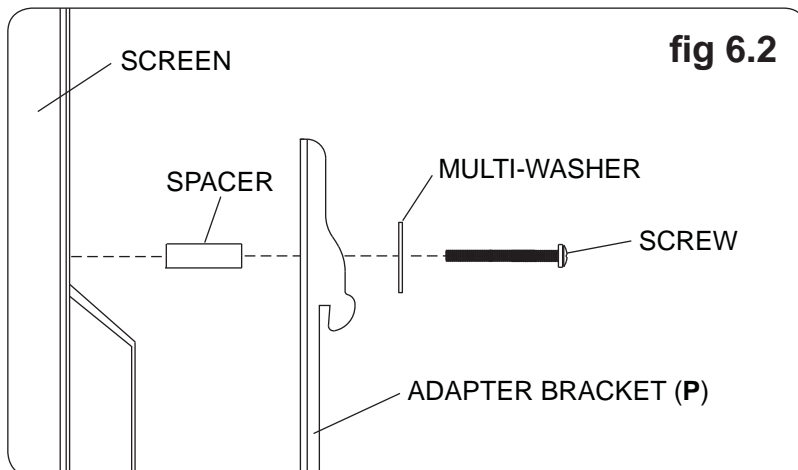

If you have any questions, please call Peerless customer care at **1-800-865-2112**.

Attaching Adapter Brackets To Adapter Plate

- 7 Hook adapter brackets (P) to adapter plate (Q) as shown in figure 7.1. Tighten safety/security screws using allen wrench (R) until safety/security screw touches bottom of wall plate as shown in detail 4. To adjust tilt of screens, loosen M10 x 15 mm penta-pin screws (L) of ceiling arm box (H) using M10 penta-pin tool (M) as shown in figure 7.2. Once desired tilt is acquired retighten the screws.

⚠ WARNING

- Always use an assistant or mechanical lifting equipment to safely lift and position the flat panel screen.
- Do not tighten screws with excessive force. Overtightening can cause damage to mount. Tighten screws to 40 in. • lb (4.5 N.M.) maximum torque.

