

DS-C560-2X2



Display size
46"-60"



Max load
500lb (227kg)
125lb per display

SMARTMOUNT.

Portable Video Wall Cart 2x2 Configuration

FOR 46" TO 60" DISPLAYS

Peerless-AV takes video wall carts to a new level of innovation. Designed for modularity, this 2x2 video wall cart configuration allows the user to create a flawless video wall with screen ranges from 46" to 60" displays. This Modular Video Wall Cart offers an 8-point micro-adjustment to create a seamless alignment without the need of tools. With a five-inch lockable caster, the cart becomes secure for safe and easy movement over various flooring surfaces. Designed for a quick set-up and tear down, the cart features a quick-connect latch for adaptors, allowing automatic engagement with mounting rails. Media storage and cable management create a sleek appearance for any application setting. With an overall weight and shipping cost reduction, this Portable Video Wall Cart makes this the ultimate video wall cart solution.

Additional Features

- ✓ Tool-less micro-adjustment at 8 points seamlessly align the displays
- ✓ Lockable 5" casters enable safe and easy maneuverability over various flooring surfaces
- ✓ Cable management through rear adjustable cable centralizing brackets
- ✓ Designed for quick set-up and tear down
- ✓ Adaptors feature a quick connect latch for automatic engagement with the mounting rails and ease of set-up
- ✓ Rear media storage shelf and cover stores components while maintaining a clean appearance
- ✓ Aluminum frame reduces the overall weight and shipping costs
- ✓ VESA® 200 x 200 up to 600 x 400mm compatible

DS-C560-2X2's tool-less micro-adjustment at 8 points helps seamlessly align the displays, creating the ultimate video wall cart solution.



■ **NO TOOLS REQUIRED FOR MICRO-ADJUSTMENT**
Simple, tool-less micro-adjustments at 8 points seamlessly align the displays

■ **QUICK SET UP AND TEAR DOWN**
Engineered to reduce installation time and cost

■ **MEDIA STORAGE**
Rear shelf provides a central location and clean appearance



DS-C560-2X2 SmartMount® Portable Video Wall Cart 2x2 Configuration for 46" to 60" Displays

Product Specifications

	DIMENSIONS (W x H x D)	PRODUCT WEIGHT	LOAD CAPACITY	FINISH	AVAILABLE COLORS
DS-C560-2X2	80.79" x 76.26" x 36.10" (2052 x 1937 x 917mm)	163lb (74.1kg)	500lb (227kg) 125lb per display	Textured	Black

Package Specifications

	PACKAGE SIZE (W x H x D)	PACKAGE SHIP WEIGHT	PACKAGE UPC CODE	PACKAGE CONTENTS	UNITS IN PACKAGE
DS-C560-2X2	37.50" x 12.50" x 84.00" (953 x 318 x 2134mm)	185lb (84kg)	735029301516	Stand, casters, display adaptors and hardware	1

Accessories

ACC-V800X: Adaptor accessory for 600 x 400 and 800 x 400mm mounting patterns

All dimensions = inch (mm)

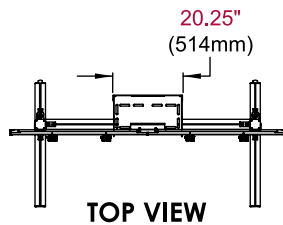

COMPATIBILITY FORMULA
Display height ≤ 36"
Display width + mount pattern width ≤ 80"

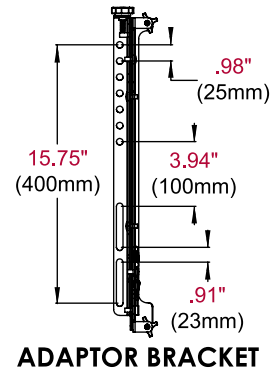
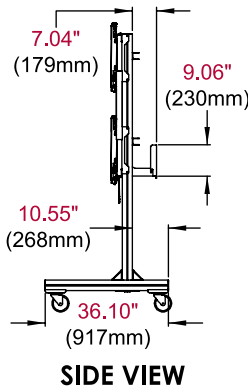
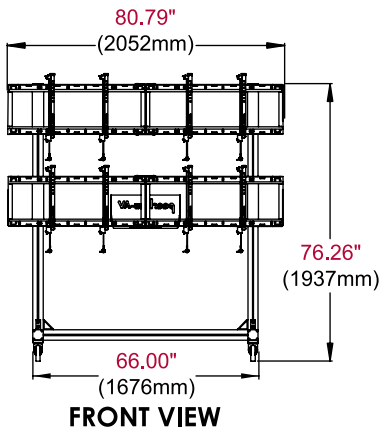

Architect Specifications

The Smartmount® Portable Video Wall Cart 2x2 Configuration shall be a Peerless-AV model DS-C560-2X2 and shall be located where indicated on the plans. Assembly and installation shall be done according to instructions provided by the manufacturer.

Visit peerless-av.com to see the complete line of AV solutions from Peerless-AV, including outdoor displays, wireless, kiosks, digital audio, display mounts, projector mounts, carts/stands, and a full assortment of accessories.

Peerless-AV
2300 White Oak Circle
Aurora, IL 60502 USA
(800) 865-2112
(630) 375-5100
Fax: (800) 359-6500

Peerless-AV Europe
Unit 3 Watford Interchange
Colonial Way, Watford
Herts, WD24 4WP
United Kingdom
+44 (0) 1923 200100
Fax: +44 (0) 1923 200101

Peerless-AV de México
Ave de las Industrias 413
Parque Industrial Escobedo
Escobedo, N.L.,
Mexico 66050
+52 (81) 8384-8300
Fax: +52 (81) 8384-8360

