

# Parts List

Description	Qty
A wall plate	1
B adaptor bracket	2
C bubble level	1
D M6 concrete anchor	4
E M6 x 60mm wood screw	4
F M4 x 12mm	4
G M4 X 25mm	4
H M6 x 12mm	4
I M6 x 25mm	4
J M8 x 12mm	4
K M8 x 25mm	4
L M8 x 50mm	4
M M6 washer	8
N M8 washer	8
O spacer	4
P M8 x 35mm	4

# peerless-AV<sup>®</sup>



**B (2)**  
adaptor bracket

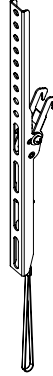

**C (1)**  
bubble level

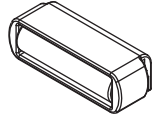

**A (1)**  
wall plate

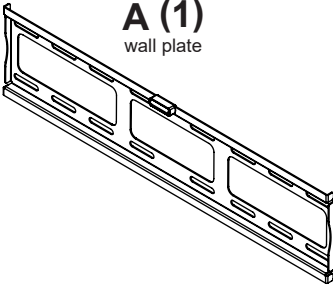

**D (4)**

M6 concrete anchor

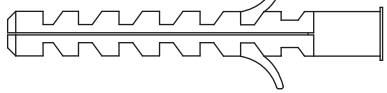

**M (8)**  
M6 washer

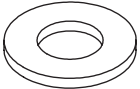

**N (8)**  
M8 washer

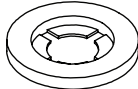

**E (4)**

M6 x 60mm wood screw

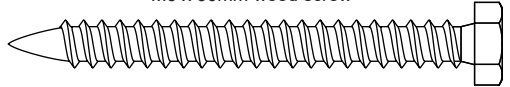

**F (4)**  
M4 x 12mm



**G (4)**  
M4 x 25mm



**H (4)**  
M6 x 12mm

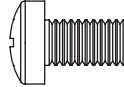

**I (4)**  
M6 x 25mm

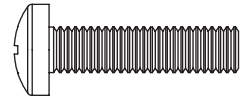

**J (4)**  
M8 x 12mm

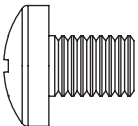

**K (4)**  
M8 x 25mm

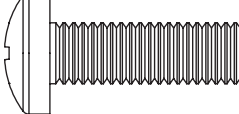

**P (4)**  
M8 x 35mm

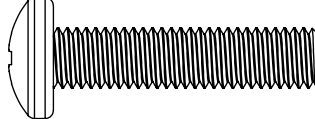

**O (4)**  
10mm height spacer

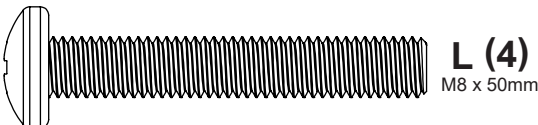
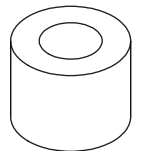

## ▲ WARNING

ENG - This product is designed to be installed on wood stud or solid concrete walls. Hardware is included for wood stud and solid concrete installation. Before installing make sure the supporting surface will support the combined load of the equipment and hardware. Screws must be tightly secured. Do not overtighten screws or damage can occur and product may fail. Never exceed the Maximum Load Capacity. Always use an assistant or mechanical lifting equipment to safely lift and position equipment. This product is intended for indoor use only. Use of this product outdoors could lead to product failure or personal injury. Be careful not to pinch fingers when operating the mount. For support please call customer care at 905-503-7733.

## ▲ ADVERTENCIA

ESP - Este producto está diseñado para ser instalado en paredes con montantes de madera o en paredes de concreto macizo. Se incluyen los accesorios para la instalación en montantes de madera o en concreto macizo. Antes de instalarlo, asegúrese de que la superficie de apoyo sostendrá la carga combinada del equipo y los fijadores. Los tornillos se tienen que fijar firmemente. No apriete los tornillos en exceso, ya que se pueden dañar y el producto podría fallar. Nunca exceda la Capacidad Máxima de Carga. Siempre cuente con la ayuda de un asistente o utilice un equipo mecánico de izar para levantar y colocar el equipo con más seguridad. Este producto está diseñado para uso en interiores solamente. Utilizar este producto en exteriores podría causar fallas del producto o lesiones a individuos. Tenga cuidado de no pincharse los dedos cuando mueva el soporte. Si necesita ayuda, por favor, llame a Servicio al Cliente de Ultralink al 905-503-7733.

## ▲ ADVERTISSEMENT

FRN - Ce produit est conçu pour une installation sur des murs à montants en bois ou en béton plein. Les pièces de fixation nécessaires à l'installation sur des montants en bois et du béton plein sont incluses. Avant de procéder à l'installation, assurez-vous que la surface de support peut soutenir la charge totale de l'équipement ainsi que des pièces de fixation. Les vis doivent être serrées au maximum. Ne serrez pas trop les vis pour éviter tout risque d'endommager le produit et de causer sa défaillance. Ne dépassez jamais la capacité de charge maximale. Pour lever et positionner l'équipement en toute sécurité, faites-vous toujours aider par une autre personne ou utilisez un dispositif de levage mécanique. Ce produit est conçu uniquement pour un usage intérieur. L'utilisation de ce produit à l'extérieur peut causer une défaillance du produit ou des blessures corporelles. Prenez garde à ne pas vous pincer les doigts lorsque vous manipulez le support. Pour toute assistance, veuillez contacter le service à la clientèle au 905-503-7733.

ENG Symbols  
ESP Símbolos  
FRN Symboles



ENG WARNING  
ESP ADVERTENCIA  
FRN ADVERTISSEMENT

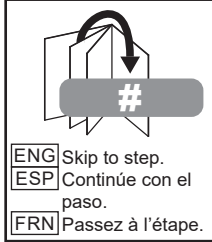

ENG Skip to step.  
ESP Continúe con el paso.  
FRN Passez à l'étape.



ENG Screws must get at least three full turns and fit snug.  
ESP Los tornillos tienen que dar, por lo menos, tres vueltas completas y quedar ajustados.  
FRN Il faut effectuer au moins trois tours de vis complets et bien serrer les vis.

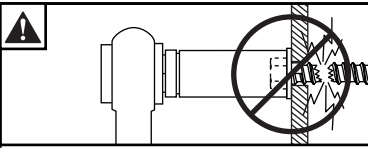

ENG Do not overtighten screws.  
ESP No apriete de más los tornillos.  
FRN Ne pas trop serrer les vis.

**ENG** Tools Needed for Assembly.  
**ESP** Herramientas necesarias para el ensamblaje.  
**FRN** Outils nécessaires au montage.

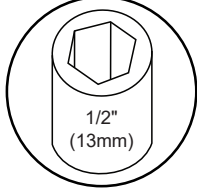
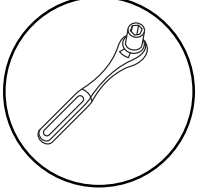
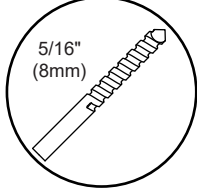
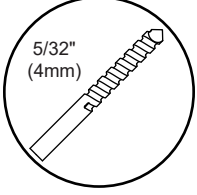
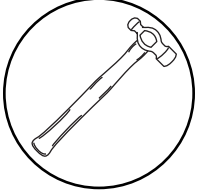
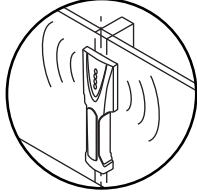
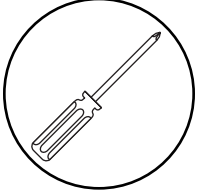
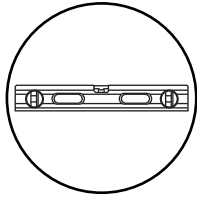
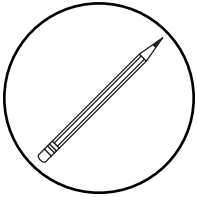

**ENG** To properly tighten screws: Tighten until screw head makes contact, then tighten another 1/2 turn. Do not overtighten screws.

**ESP** Apriete adecuado de los tornillos: Apriete hasta que la cabeza del tornillo haga contacto y luego apriete otra 1/2 vuelta. No apriete de más los tornillos.

**FRN** Pour bien serrer les vis : Serrez jusqu'à ce que la tête de la vis entre en contact, puis serrez encore d'un 1/2 tour. Ne serrez pas trop les vis.

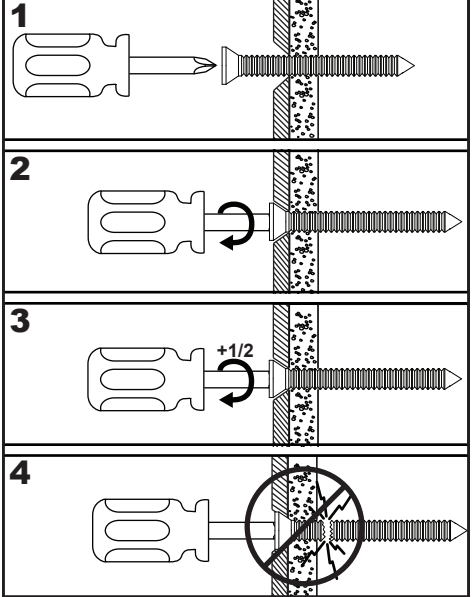

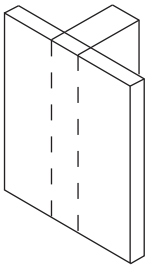
**1**

ENG Wood stud wall.  
 ESP Pared de madera.  
 FRN Mur en bois.

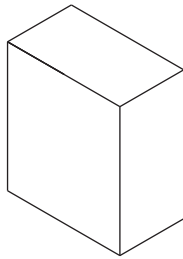
**1a**

ENG Concrete.  
 ESP Concreto.  
 FRN Béton plein.

**1b****1a****▲ WARNING**

ENG - When installing Peerless wall mounts on a wood stud wall covered with gypsum board (drywall), verify that the wood studs are a minimum of 2" x 4" nominal size. Do not install over gypsum board thicker than 3/8".

**▲ ADVERTENCIA**

ESP - Cuando vaya a instalar soportes de pared de Peerless en paredes con montantes de madera recubiertas con yeso-cartón (gypsum board) verifique que los montantes tengan un tamaño mínimo de 2" x 4". No instale en yeso-cartón (gypsum board) de más de 3/8" de grosor.

**▲ ADVERTISSEMENT**

FRN - Lors de l'installation de supports muraux Peerless sur un mur à montants en bois recouvert de plaque de plâtre (cloison sèche), assurez-vous que les montants en bois ont une taille nominale d'au moins 2 po x 4 po (5 cm x 10 cm). Ne pas installer sur une plaque de plâtre dont l'épaisseur est supérieure à 3/8 po (10 mm).

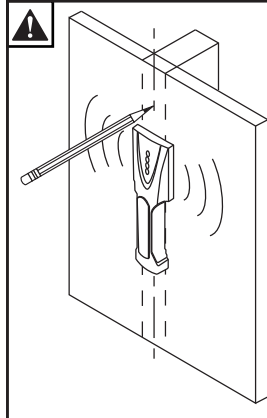
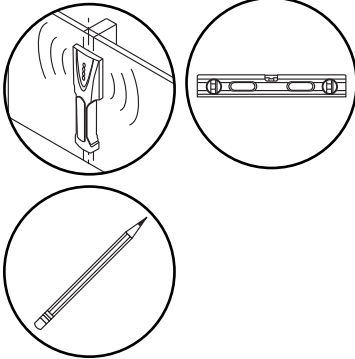
**1a-1**

ENG Use stud finder to locate and mark stud center lines.

ESP Marque las líneas centrales del montante.

FRN Marquez la ligne médiane du montant.

## 1a-2

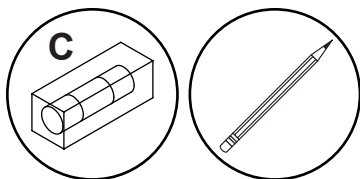

**ENG** Level wallplate. Mark mounting holes on stud center lines.

**ESP** Marque los orificios de montaje en las líneas centrales del montante.

**FRN** Marquez les trous de fixation le long de la ligne médiane du montant.

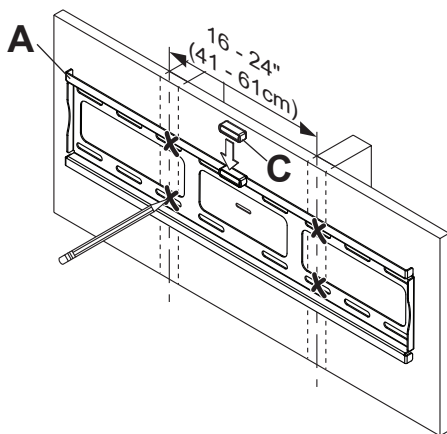

## 1a-3

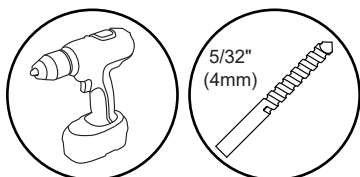

**ENG** Drill mounting holes into supporting surface (2.5" (64mm) minimum depth required).

**ESP** Taladre los agujeros de montaje en la superficie de apoyo; se requiere una profundidad mínima de 2.5" (64mm).

**FRN** Percez les trous de fixation dans la surface de support, une profondeur minimale de 2,5 po (64mm) est requise.

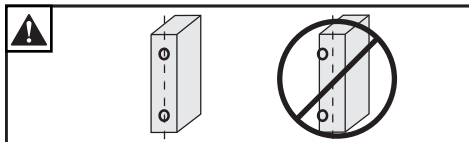
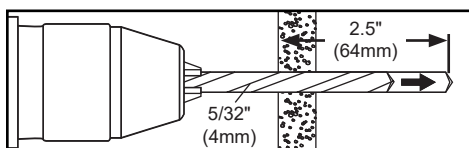

**ENG** Mounting hole must center on stud.

**ESP** El orificio debe quedar centrado en el montante.

**FRN** Le trou doit être centré sur le montant.

## 1a-4

**ENG** Level wallplate. Install using wood screws provided.

**ESP** Nivele e instale.

**FRN** Mettez à niveau et procédez au montage.

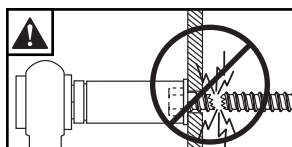
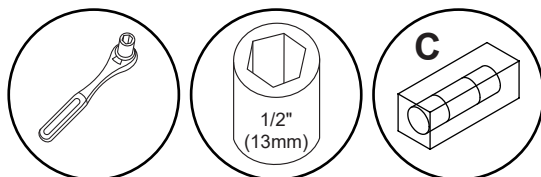

**ENG** Maximum 80 in. • lb (9 N.M.).

**ESP** Máxima 80 in. • lb (9 N.M.).

**FRN** Maximum 80 in. • lb (9 N.M.).

**M (4)**

**E (4)**

**A**



# 1b

## ▲ WARNING

ENG - When installing Peerless wall mounts on a concrete wall, the wall must be at least 8" thick with a minimum compressive strength of 2000 psi. Never attach concrete expansion anchors to concrete covered with plaster, drywall or other finishing material.

## ▲ ADVERTENCIA

ESP - Cuando vaya a instalar soportes de pared de Peerless en paredes de concreto, las paredes tienen que tener, por lo menos, 8" de grosor con una resistencia a la compresión de 2000 psi como mínimo. Nunca fije los anclajes de expansión para concreto a superficies de concreto recubiertas con yeso, yeso-cartón u otro material de acabado.

## ▲ ADVERTISSEMENT

FRN - Lors de l'installation de supports muraux Peerless sur un mur en béton, celui-ci doit avoir au moins 8 po (20 cm) d'épaisseur et une résistance à la compression d'au moins 2 000 psi. Ne fixez jamais des chevilles à expansion pour béton au béton recouvert d'une de plâtre, d'une cloison sèche ou de tout autre matériau de finition.

# 1b-1

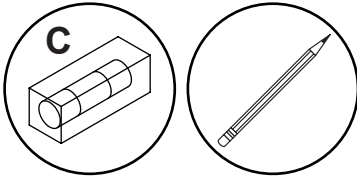

ENG Level wallplate. Mark mounting holes.  
ESP Marque los orificios de montaje.  
FRN Marquez les trous de fixation.

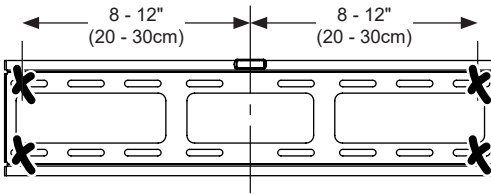
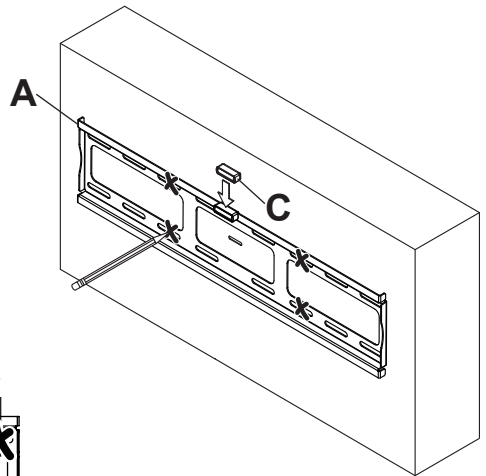

## 1b-2

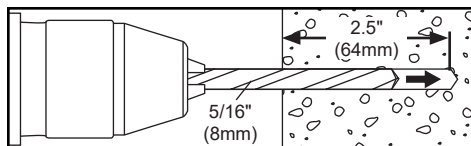
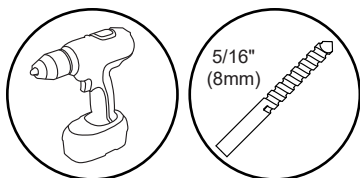

**ENG** Drill mounting holes into supporting surface (2.5" (64mm) minimum depth required).

**ESP** Taladre los agujeros de montaje en la superficie de apoyo; se requiere una profundidad mínima de 2.5" (64mm).

**FRN** Percez les trous de fixation dans la surface de support, une profondeur minimale de 2,5 po (64mm) est requise.

## 1b-3

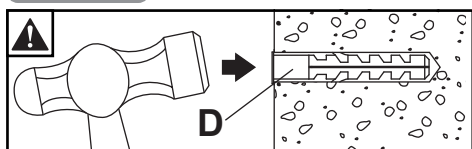

**ENG** Insert anchor flush to concrete.

**ESP** Inserte el anclaje a ras con el concreto.

**FRN** Insérez la cheville d'ancrage au ras du béton.

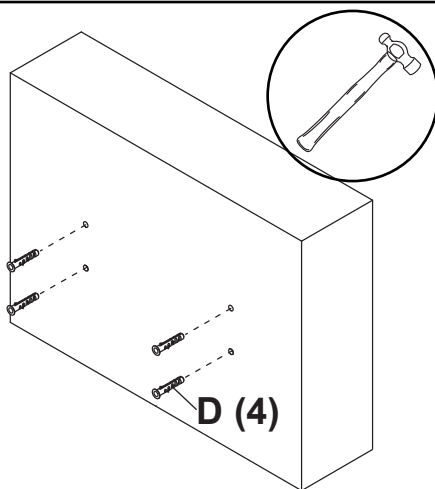

## 1b-4

**ENG** Level wallplate. Install using wood screws provided.

**ESP** Nivele e instale.

**FRN** Mettez à niveau et procédez au montage.

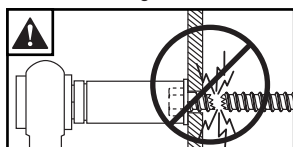

**ENG** Maximum 80 in. • lb (9 N.M.).

**ESP** Máxima 80 in. • lb (9 N.M.).

**FRN** Maximum 80 in. • lb (9 N.M.).

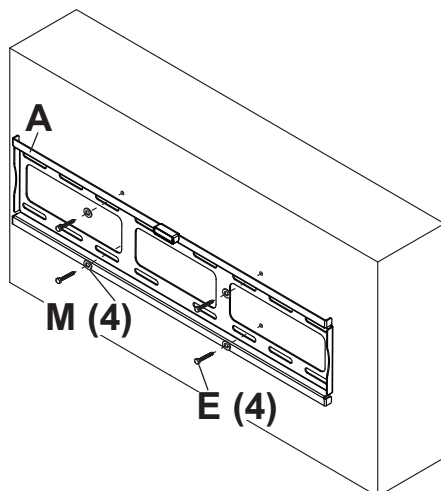
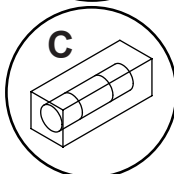
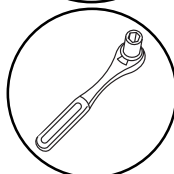
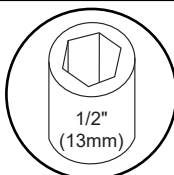

## 2

- ENG Center adaptor brackets vertically on back of screen.  
 ESP Centre verticalmente los soportes en la pantalla.  
 FRN Centrez les supports à la verticale de l'écran.

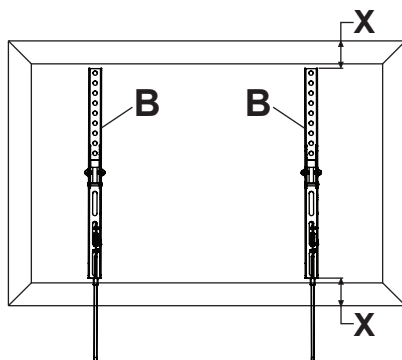

## 3

- ENG Use of spacers and washers is optional.  
 ESP Uso de espaciadores y arandelas opcional.  
 FRN Facultatif utilisation d'entretoises de rondelles.

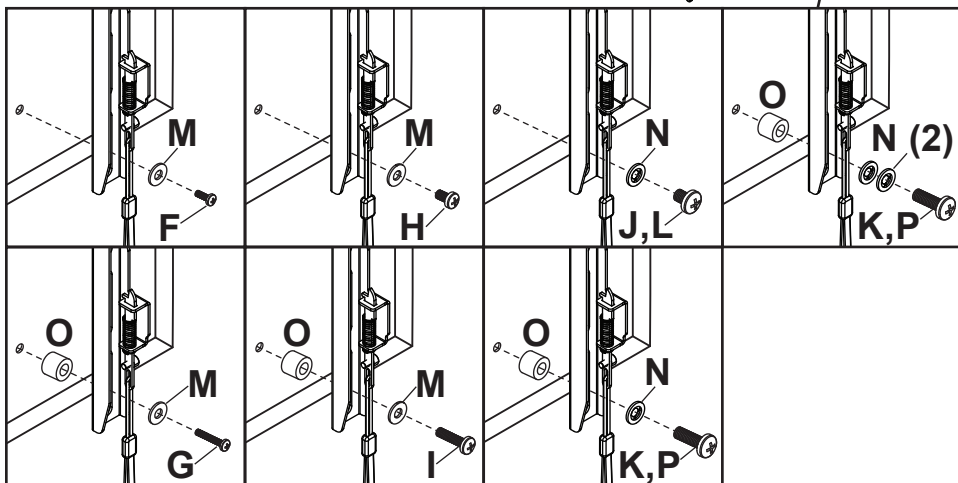
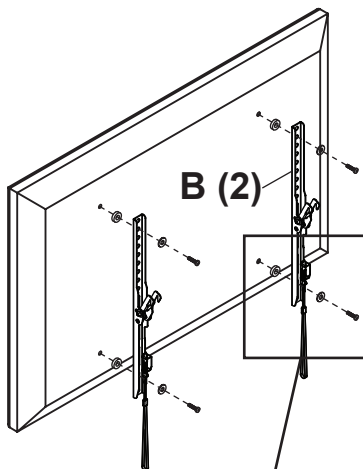
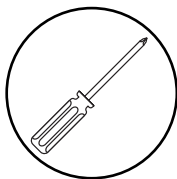



4

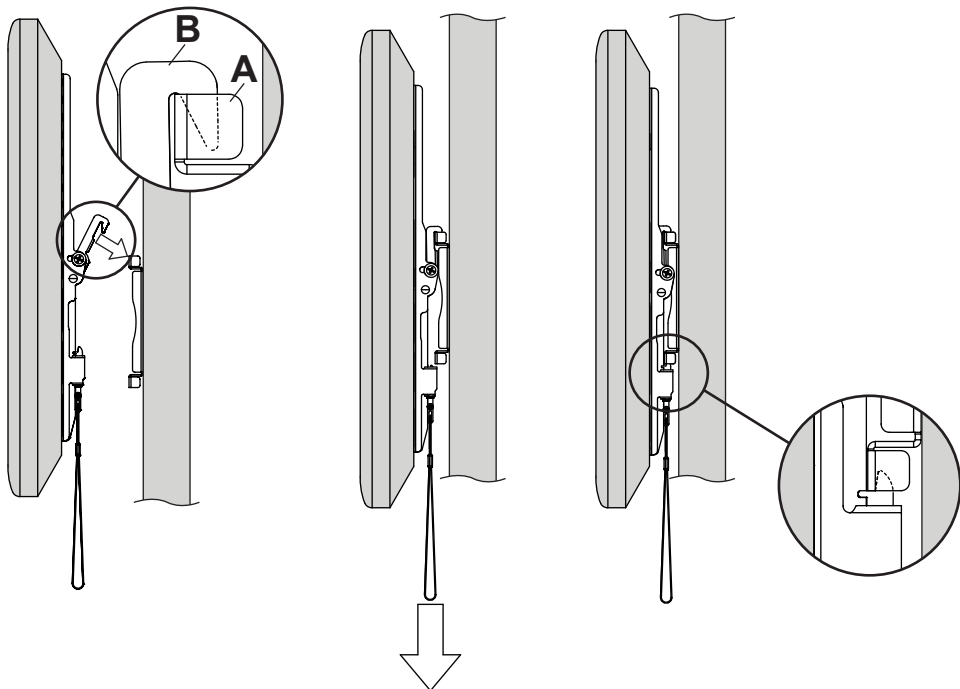

5

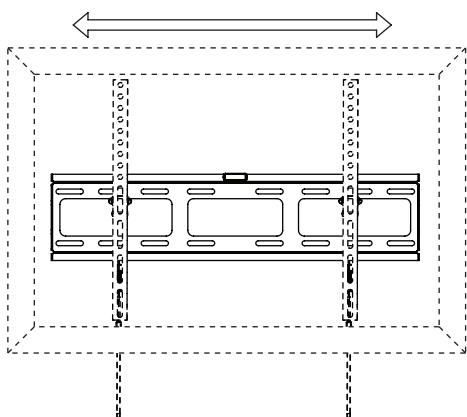

6

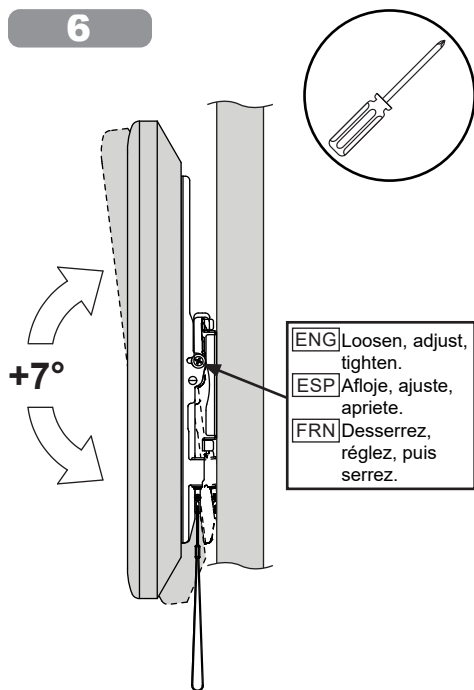

# 7

- ENG Optional: Remove display
- ESP Opcional: Retire la pantalla
- FRN Facultatif: Enlever l'écran

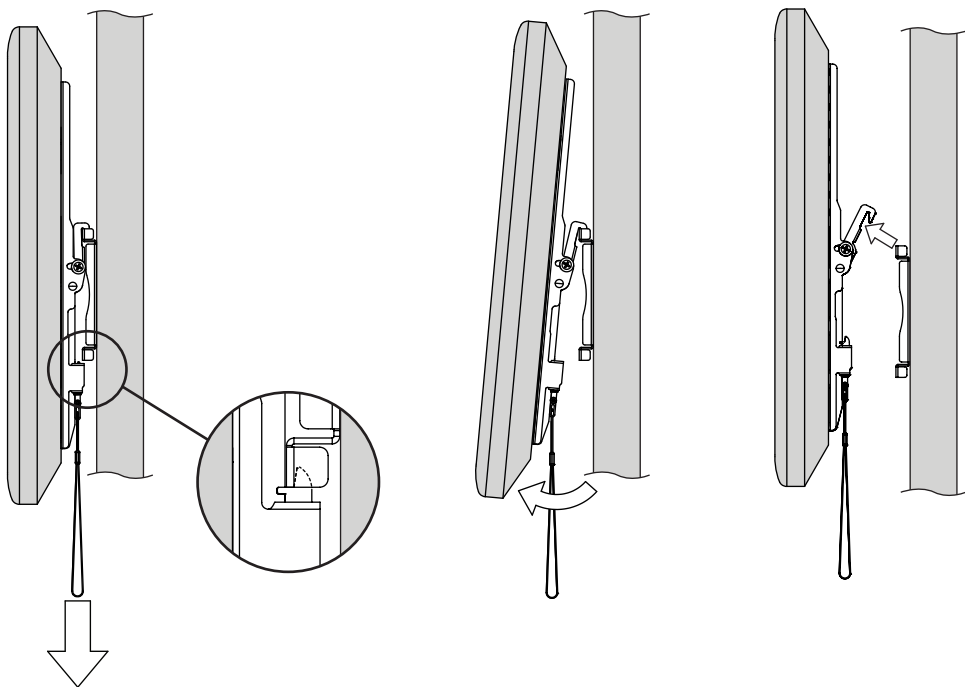

ENG	This page intentionally left blank.
ESP	Página en blanco.
FRN	Cette page a été laissée en blanc intentionnellement.

ENG Warranty  
ITL Garanzia

ESP Garantía  
ČES Záruka

FRN Garantie  
SLK Záruka

DEU Garantie  
POR Garantia

NEL Garantie  
TÜR Garanti

[www.peerless-av.com/warranty](http://www.peerless-av.com/warranty)

**peerless-AV<sup>®</sup>**

**Peerless-AV**

2300 White Oak Circle  
Aurora, IL 60502  
Email: [tech@peerlessmounts.com](mailto:tech@peerlessmounts.com)  
Ph: (800) 865-2112  
Fax: (800) 359-6500  
[www.peerless-av.com](http://www.peerless-av.com)

© 2020, Peerless Industries, Inc.

**Peerless-AV Europe**

Unit 3 Watford Interchange,  
Colonial Way, Watford, Herts,  
WD24 4WP, United Kingdom  
Customer Care  
44 (0) 1923 200 100  
[www.peerless-av.com](http://www.peerless-av.com)

© 2020, Peerless Industries, Inc.

**Peerless-AV América Latina**

Av. de las Industrias 413  
Parque Industrial Escobedo  
General Escobedo N.L., México 66062  
Servicio al Cliente  
01-800-849-65-77  
[www.peerless-av.com](http://www.peerless-av.com)

© 2020, Peerless Industries, Inc.