

IWB600-2SB

Whiteboard Mount

For attaching over existing marker boards and chalkboards

The IWB600-2SB wall mount is a cost effective solution for effortlessly adding interactive whiteboards to the classroom or boardroom. Designed to fit directly over the existing chalkboard, the mount is easy to install and simple to adjust. For whiteboard compatibility, please see features below.



Max load: 70lb (32kg)

FEATURES

- Depth adjustable wall brackets
- Hook-on design allows for single person installation
- Vertical and horizontal whiteboard adjustment
- Mounts over the existing marker board/chalkboard
- Compatible with:
 - 64" SMART Board SB660
 - 77" SMART Board SB680
 - 77" Marsh Board PR4050000
 - 63" Hitachi Starboard DUO
 - 77" Hitachi Starboard DUO
 - 77" Hitachi Starboard TRIO
 - 88" Hitachi Starboard DUO
 - 77" Interwrite DualBoard 1277
 - 64" ActivBoard 164
 - 78" ActivBoard 178
 - 78" ActivBoard 378 PRO
 - 87" ActivBoard 387 PRO
 - 95" ActivBoard 395 PRO
- Some whiteboards may require bumpers, ACC956, to be added between the mount and the board in order to make the board more rigid

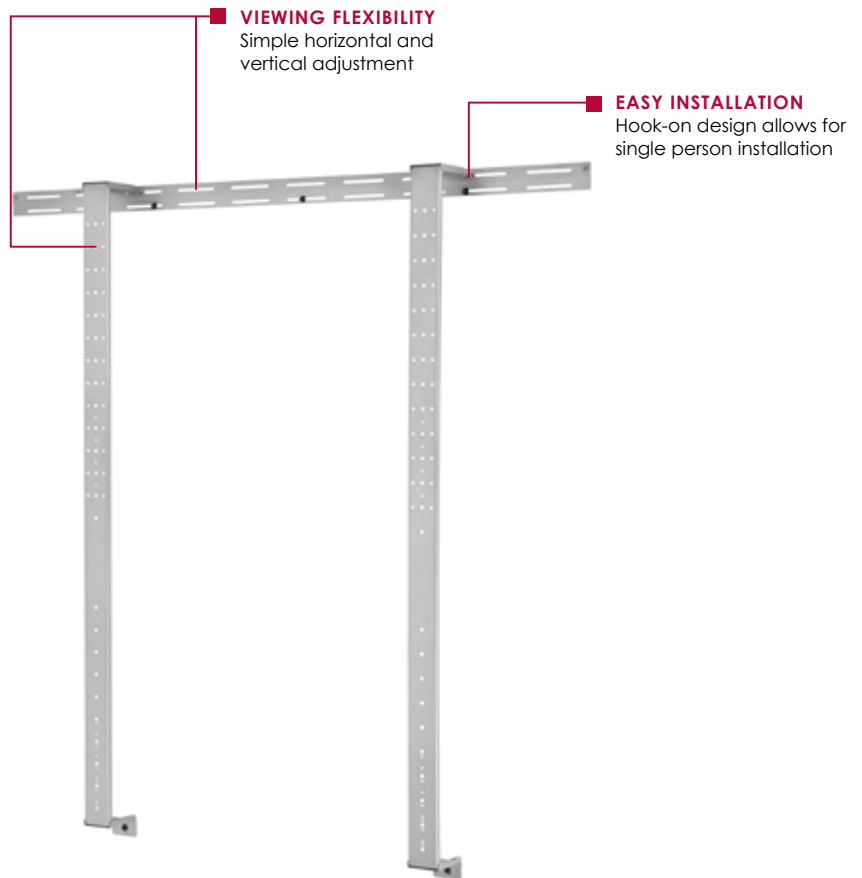

Clean Installation



Depth Adjustable Safety Lock



IWB600-2SB: Whiteboard Mount for attaching over existing marker boards and chalkboards

Product Specifications

	DIMENSIONS (W x H x D)	PRODUCT WEIGHT	LOAD CAPACITY	FINISH	AVAILABLE COLORS
IWB600-2SB	59" x 58.8" x 5.79" (1499 x 1493 x 147mm)	17.5lb (7.9kg)	70lb (32kg)	Powder coat	Silver

Package Specifications

	PACKAGE SIZE (W x H x D)	PACKAGE SHIP WEIGHT	PACKAGE UPC CODE	PACKAGE CONTENTS	UNITS IN PACKAGE
IWB600-2SB	61" x 5.75" x 3.25" (1549 x 146 x 82mm)	19.5lb (8.8kg)	735029266815	Wall brackets, vertical rails and whiteboard attaching hardware	1

Accessories

ACC956: Adhesive Bumpers

All dimensions = inch (mm)

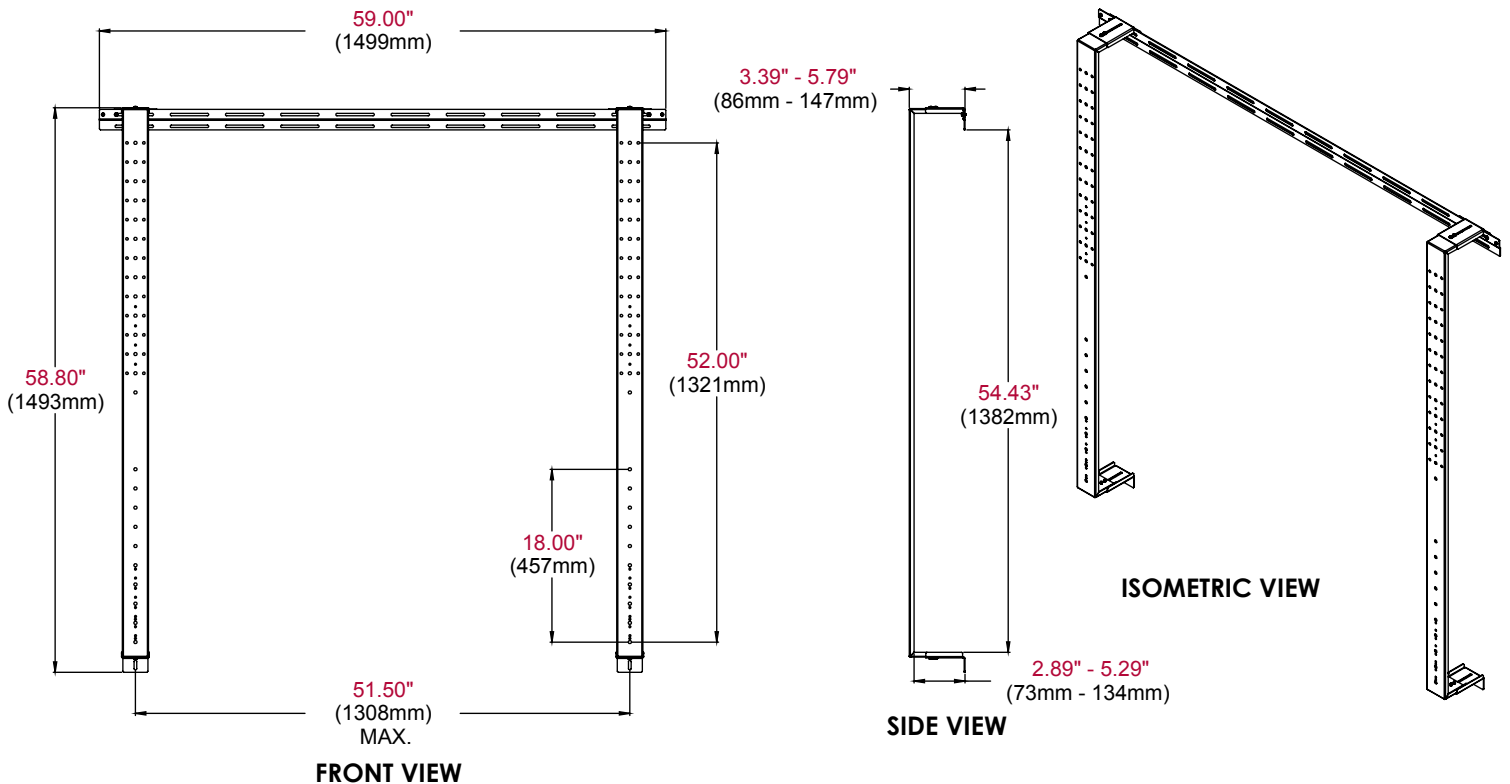

ARCHITECTS SPECIFICATIONS

The Whiteboard mount shall be a Peerless model IWB600-2SB and shall be located where indicated on the plans. It shall be constructed of heavy gauge cold rolled steel and finished with scratch resistant silver fused epoxy. Assembly and installation shall be done according to instructions provided by the manufacturer.