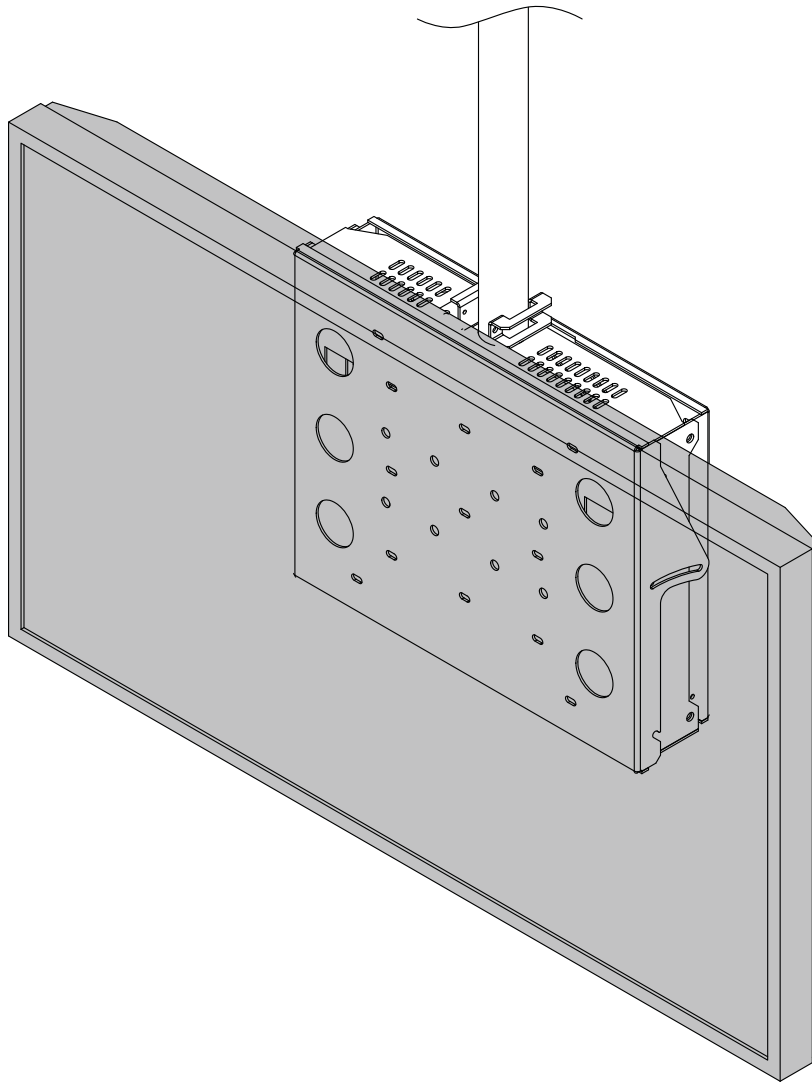




## Installation and Assembly: Mount - Wall/Ceiling Mount

---

**Model: DST360**

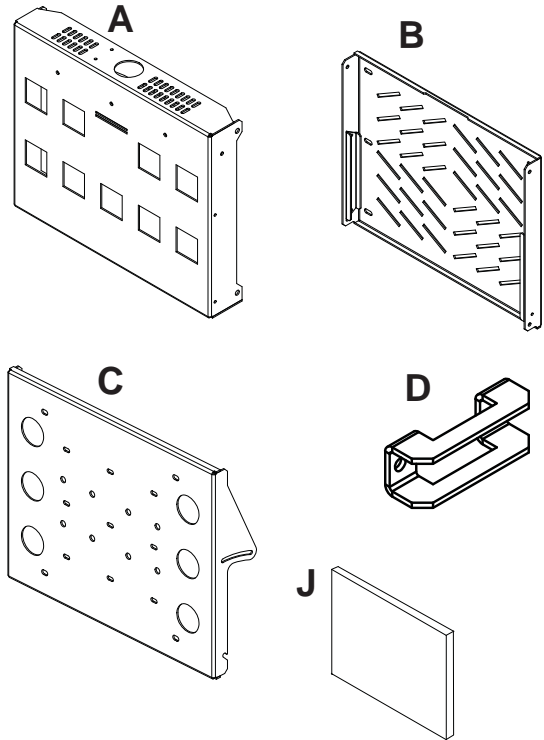


Max Load Capacity: 150 lb (68. kg)

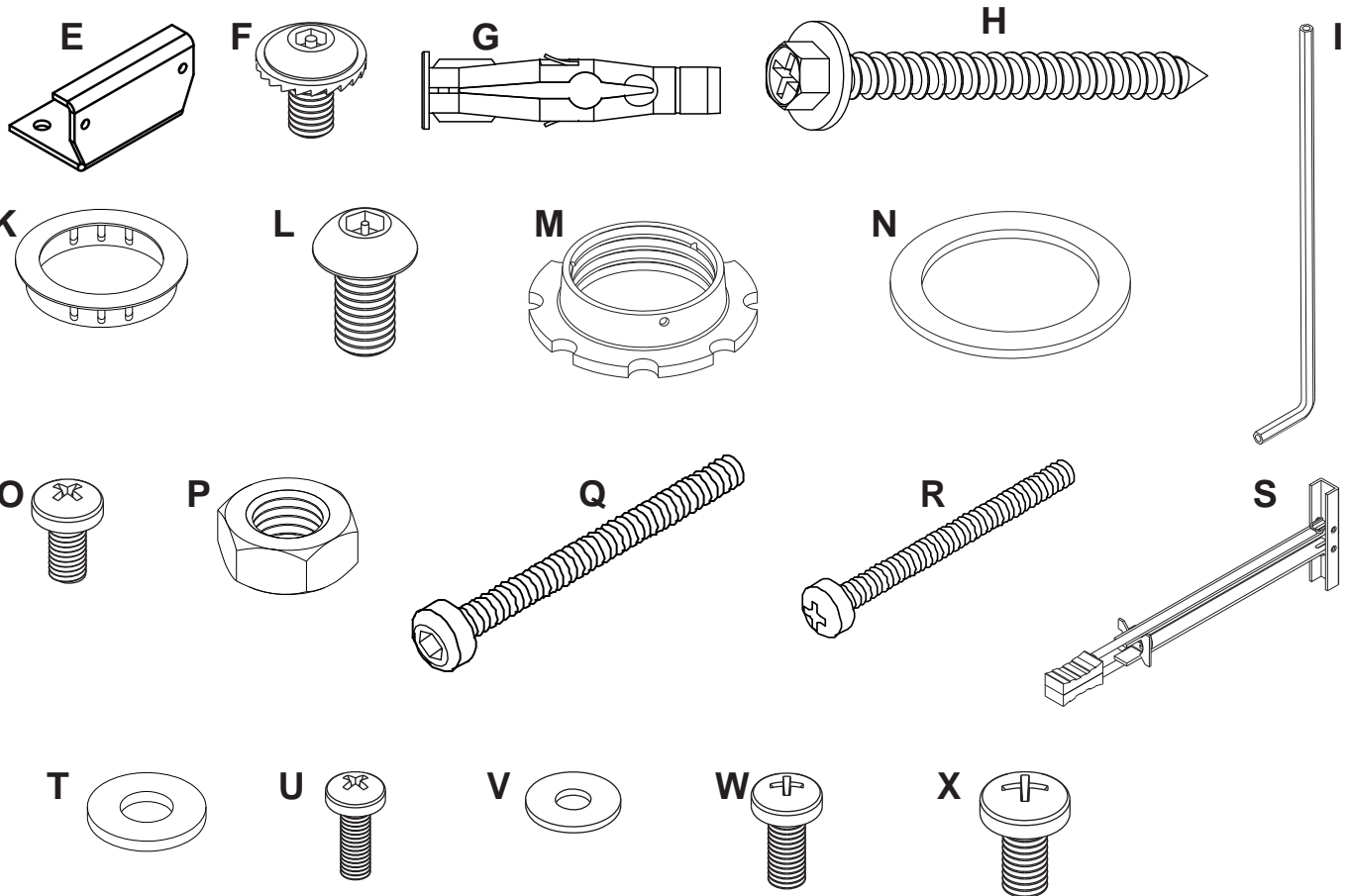
**NOTE:** Read instruction sheet before you start installation and assembly.

## PARTS LIST

Description	Qty.	Part #
A main support box	1	145-1050
B access plate	1	145-1049
C adapter plate	1	145-1172
D pinch bracket	1	130-1073
E yaw lock bracket	1	140-1019
F M6 x 12 mm socket pin serrated washer head screw	6	510-1050
G concrete anchor	6	590-0320
H #14 x 2.5 hex phillips wood screw	6	5S1-015-C03
I 4 mm allen wrench	1	560-9646
J rubber pad	4	590-1159
K 2" snap bushing	1	590-1149
L M8 x 15 mm socket pin screw	4	520-1068
M retaining collar	1	1800-375
N washer	1	540-9432
O M5 x 10 mm type F screw	1	520-9250
P M5 nylock nut	2	530-1019
Q M5 x 55 mm socket screw	2	520-1193
R 1/4 - 20 x 2.5 phillips screw	6	520-9521
S toggler	6	560-9708
T 1/4 - 20 washer	6	540-9440
U M4 x 12 mm phillips screw	4	504-9013
V #8 washer	4	540-1001
W M5 x 12 mm phillips screw	4	520-1027
X M6 x 12 mm phillips screw	4	520-1128



**NOTE:** Some parts may appear slightly different than illustrated

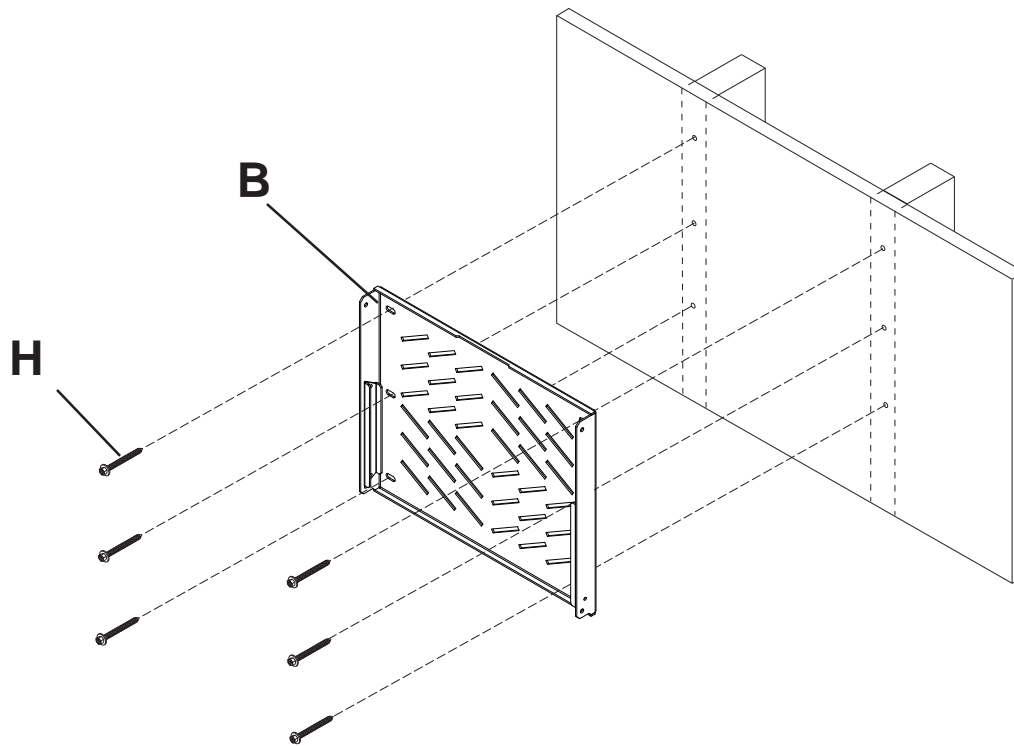


## Installation to Wood Stud Wall

### ⚠ WARNING

- Installer must verify that the supporting surface will safely support the combined load of the equipment and all attached hardware and components.
- Tighten wood screws so that wall plate is firmly attached, but do not overtighten. Overtightening can damage the screws, greatly reducing their holding power.
- Never tighten in excess of 80 in. • lb (9 N.M.).
- Make sure that mounting screws are anchored into the center of the stud. The use of an "edge to edge" stud finder is highly recommended.
- Hardware provided is for attachment of mount through standard thickness drywall or plaster into wood studs. Installers are responsible to provide hardware for other types of mounting situations.

- 1 Using access plate (B) as a template, drill six 5/32" (4 mm) dia. holes to a minimum depth of 2.5" (64 mm). Attach access plate (B) to centers of wood studs using six #14 x 2.5" wood screws (H) shown.

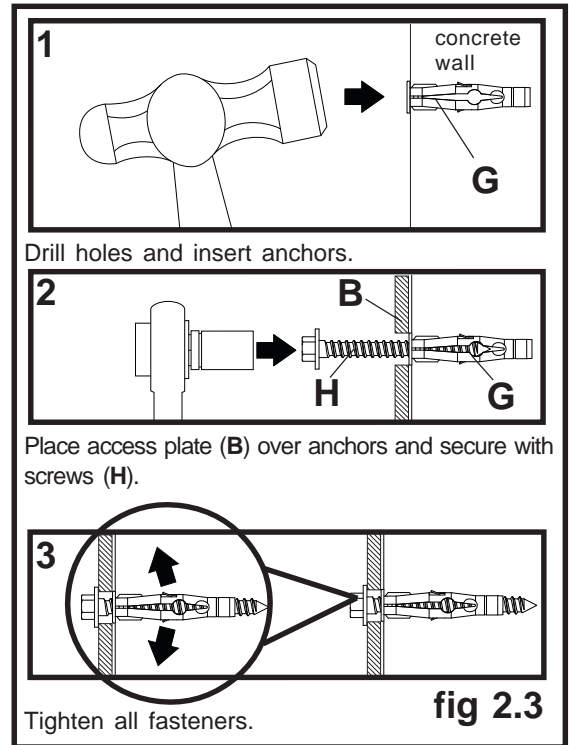


# Installation to Solid Concrete and Cinder Block Wall

## ⚠ WARNING

- When installing Peerless wall mounts on cinder block, verify that you have a minimum of 1-3/8" of actual concrete thickness in the hole to be used for the concrete anchors. Do not drill into mortar joints! Be sure to mount in a solid part of the block, generally 1" minimum from the side of the block. Cinder block must meet ASTM C-90 specifications. It is suggested that a standard electric drill on slow setting is used to drill the hole instead of a hammer drill to avoid breaking out the back of the hole when entering a void or cavity.
- Concrete must be 2000 psi density minimum. Lighter density concrete may not hold concrete anchor.
- Make sure that the supporting surface will safely support the combined load of the equipment and all attached hardware and components.

- 2 Position access plate (B) at desired position on wall. Use access plate (B), making sure that it is level, as a template to mark holes. Drill six 5/16" (8 mm) dia. holes to a minimum depth of 2-1/2" (64 mm). Concrete must be 2000 psi density minimum. Insert anchors (G) in holes flush with wall as shown in figure 2.3. Place access plate (B) over anchors and secure with six #14 x 2-1/2" (6 mm x 65 mm) wood screws (H) as shown in figure 2.4. Make sure wall plate is level and tighten all fasteners.

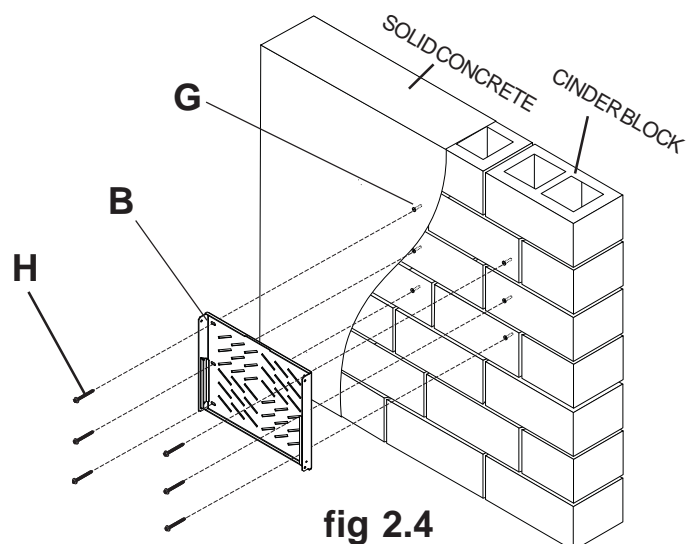
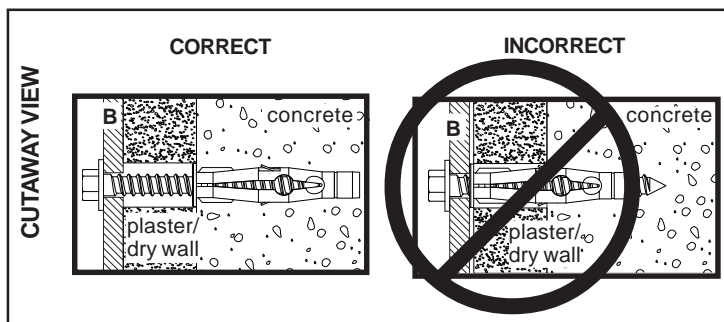


## ⚠ WARNING

- Tighten wood screws firmly, but do not overtighten. Overtightening can damage the screws, greatly reducing their holding power.
- Never tighten in excess of 80 in • lb (9 N.M.).

## ⚠ WARNING

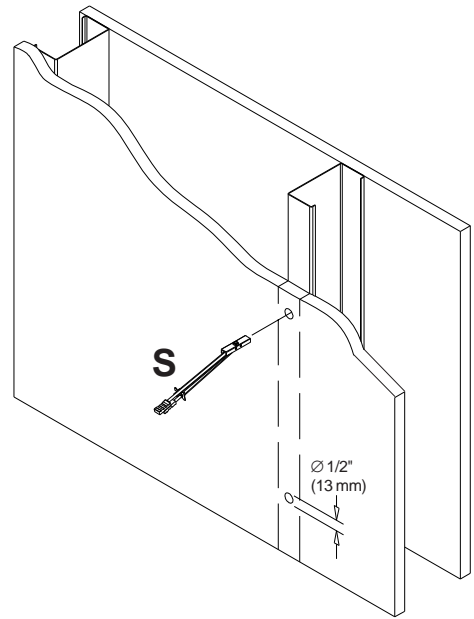
- Concrete anchors are **not** intended for attachment to concrete wall covered with a layer of plaster, drywall, or other finishing material as shown below. If mounting to concrete wall covered with plaster/drywall is unavoidable, plaster/drywall (up to 5/8" thick) must be counterbored as shown below. Be sure concrete anchors do not pull away from concrete when tightening screws. If plaster/drywall is thicker than 5/8", custom fasteners must be supplied by installer.



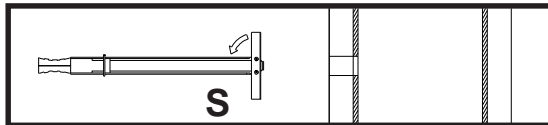
- 3 FOR METAL STUD WALLS ONLY:** Drill six 1/2" (13 mm) dia. holes through drywall and studs at locations corresponding to wall plate. Insert togglers (S) as shown below.

**⚠ WARNING**

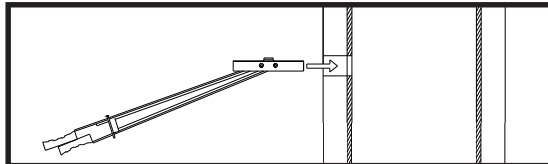
- Product must be mounted through drywall that has a minimum thickness of 1/2" and into metal studs, 26 gauge or heavier.
- Make sure that togglers are anchored into the center of the studs as shown in figure 3.1. The use of an "edge to edge" stud finder is highly recommended.



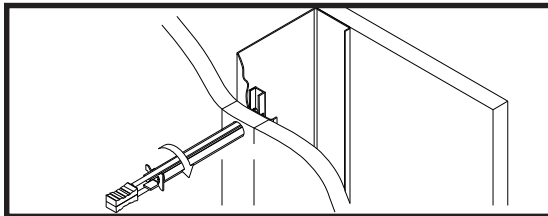
- 3-1** Pivot end of toggler (S).



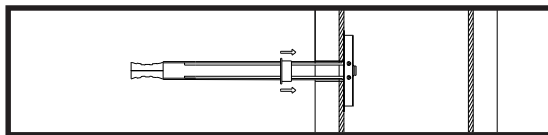
- 3-2** Push into hole.



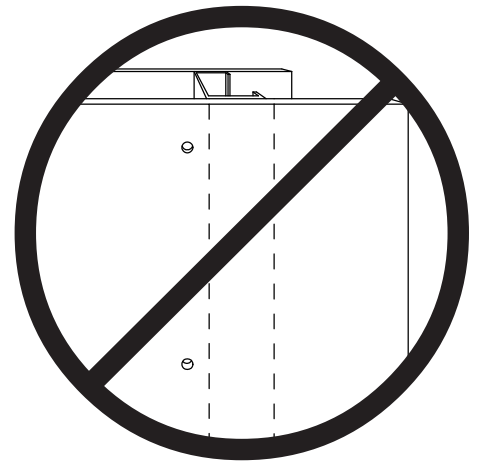
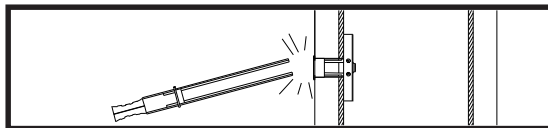
- 3-3** Rotate toggler (S) clockwise to wedge it against inside walls of metal stud.



- 3-4** Slide plastic cap forward while pulling back firmly on ring.

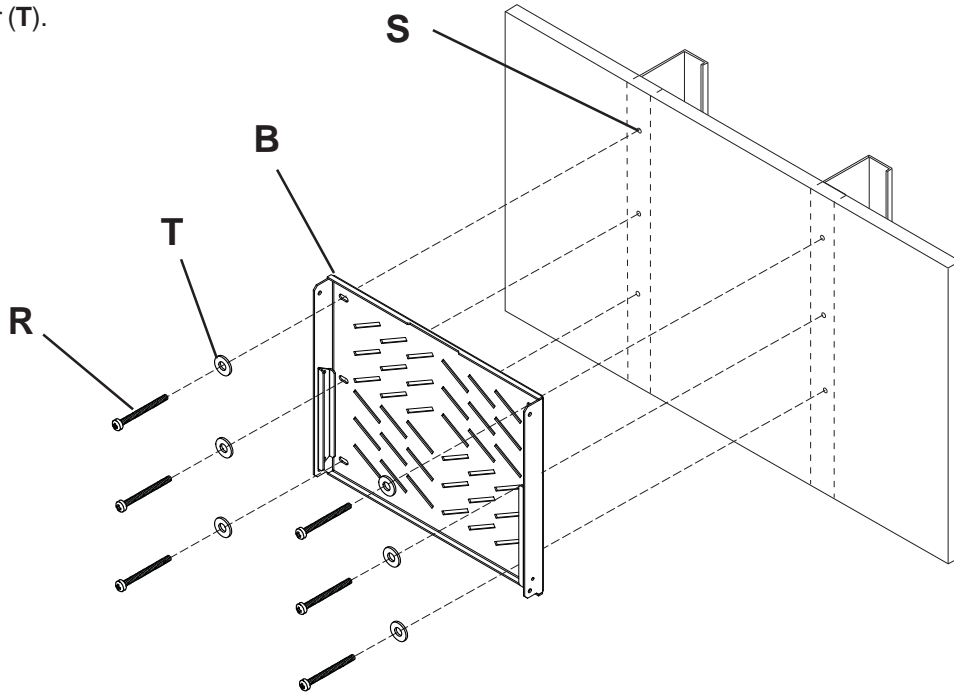
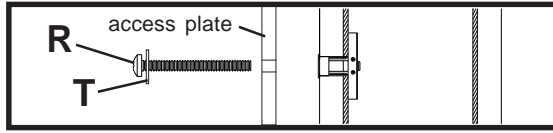


- 3-5** Break off excess.

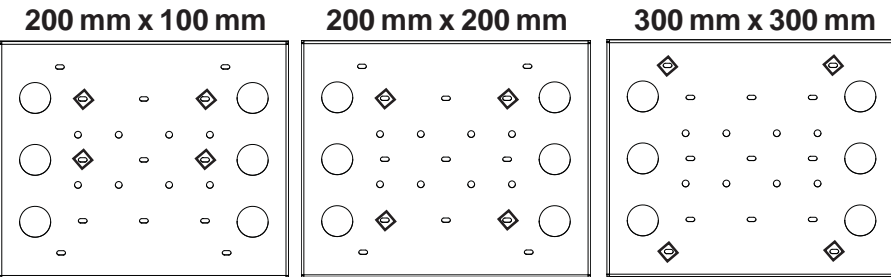


**fig. 3.1**

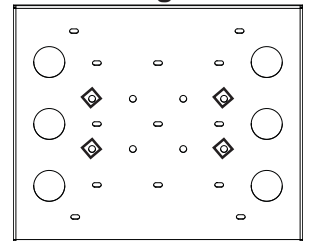
**3-6** Align wall plate with hole in wall and fasten using 1/4-20 x 2.5" screw (R) and 1/4" washer (T).



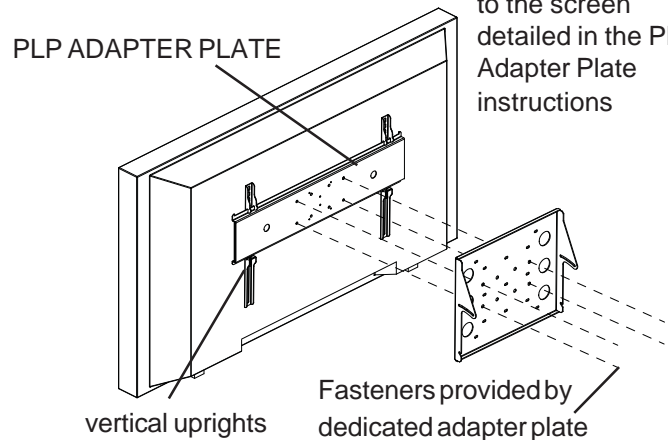
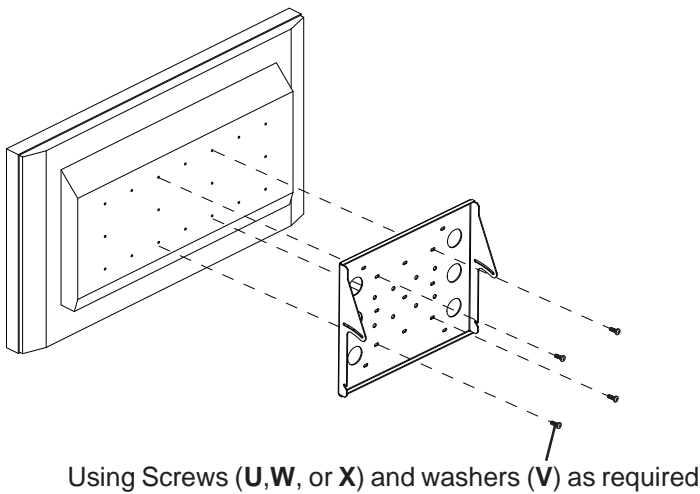
**4** Select mounting hole pattern and secure adapter plate (C) to screen using screws (U,W, or X) and washers (V) if required.



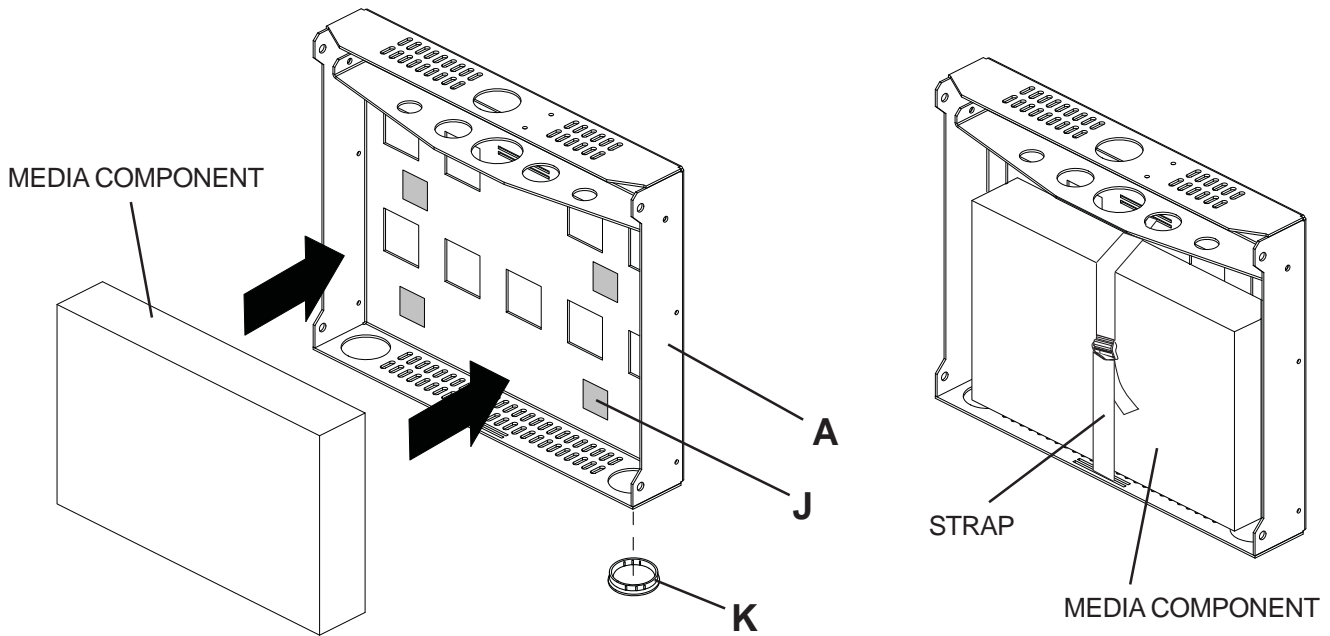
**PLP Adapter Plate Mounting Holes**



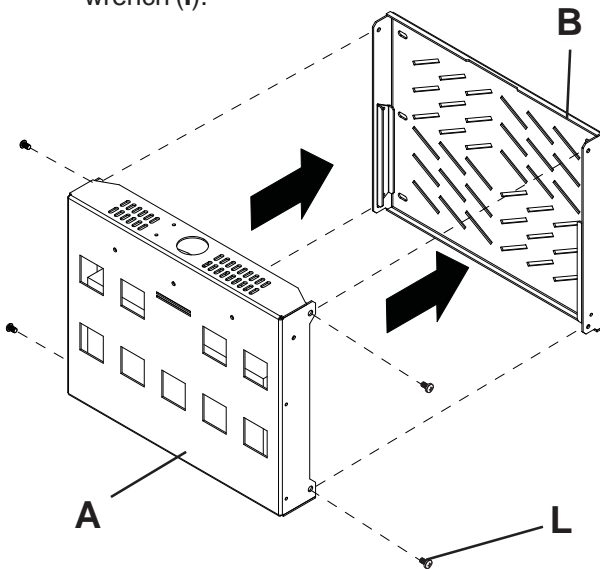
**NOTE:** First attach the vertical uprights to the screen detailed in the PLP Adapter Plate instructions



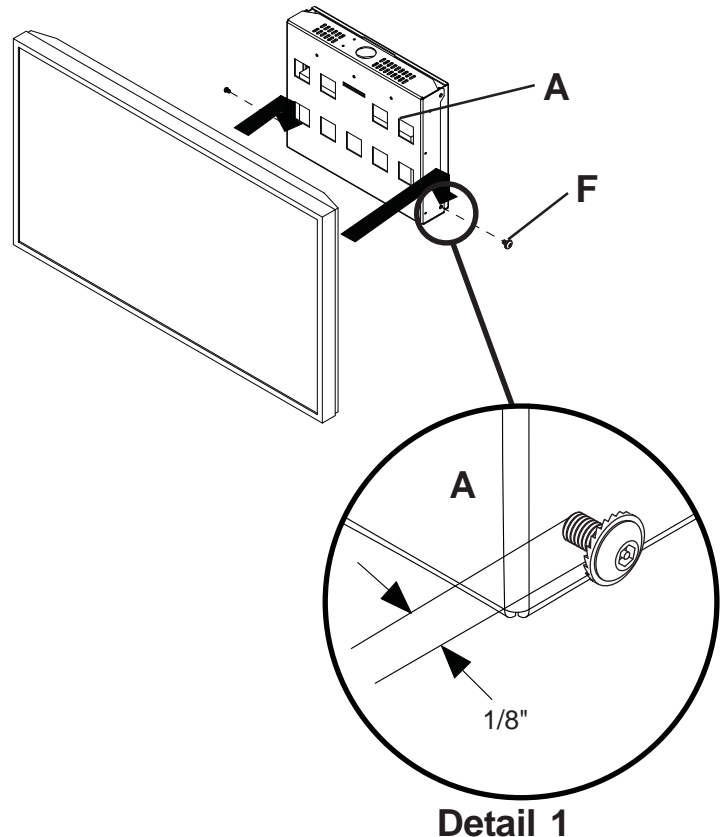
- 5 Secure media component to main support box (A) using strap provided with main support box (A), and rubber pads (J) for support and ventilation. Secure 2" snap bushing (K) as desired.



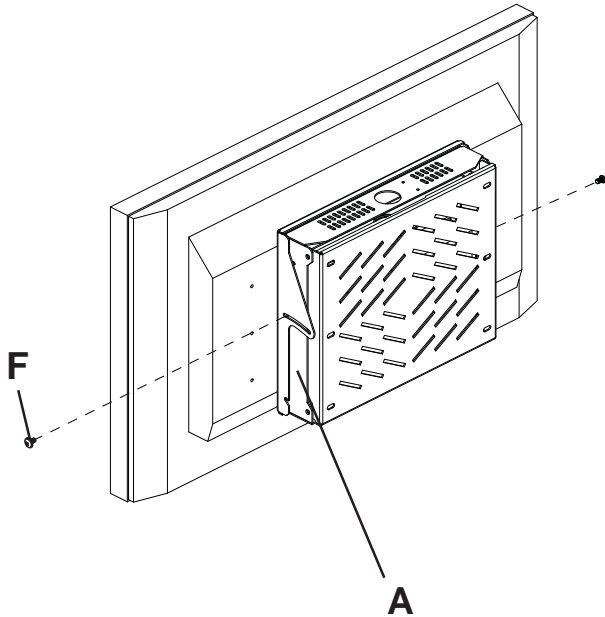
- 6 Secure main support box (A) to access plate (B) with four M8 x 15 mm socket pin screws (L). Tighten using allen wrench (I).



- 7 Thread two M6 x 12 mm socket pin screws (F) into main support box (A) leaving 1/8" exposed thread as shown in detail 1. Hook screen and adapter plate onto exposed screws.

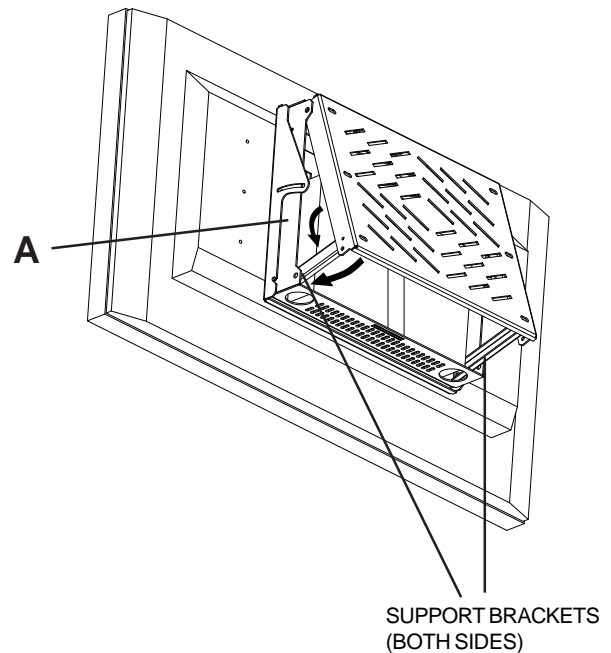
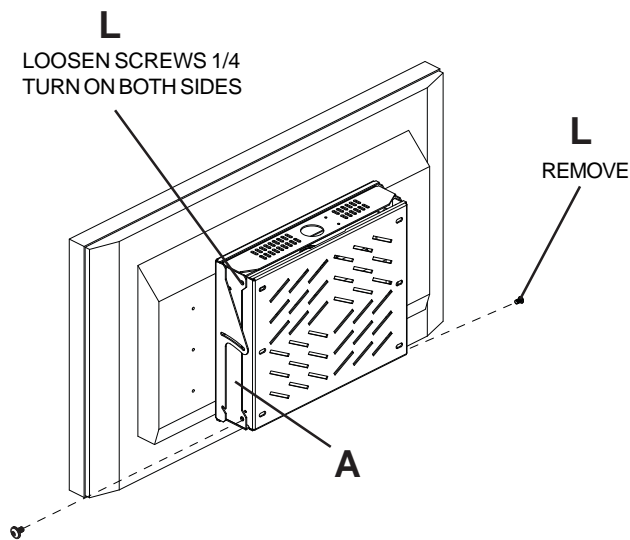


- 8 Secure two M6 x 12 mm socket pin screws (F) into main support box (A) at desired tilt. Tighten using allen wrench (I).



## Accessing Media Component

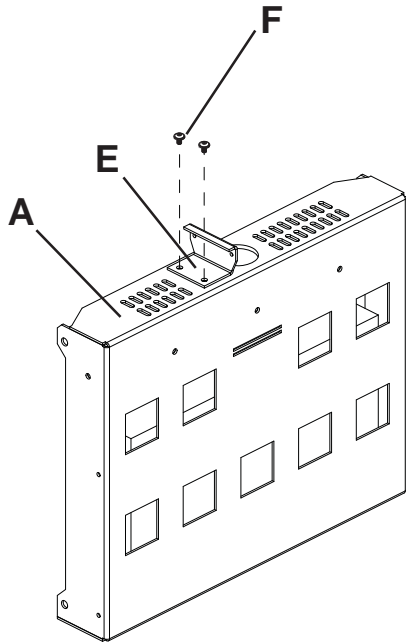
- 9 Loosen top two M8 x 15 mm socket pin screws (L) 1/4 turn and temporarily remove bottom two M8 x 15 mm socket pin screws (L) on main support box (A) as shown. Swing screen forward and swing support brackets downward to brace screen in open position.





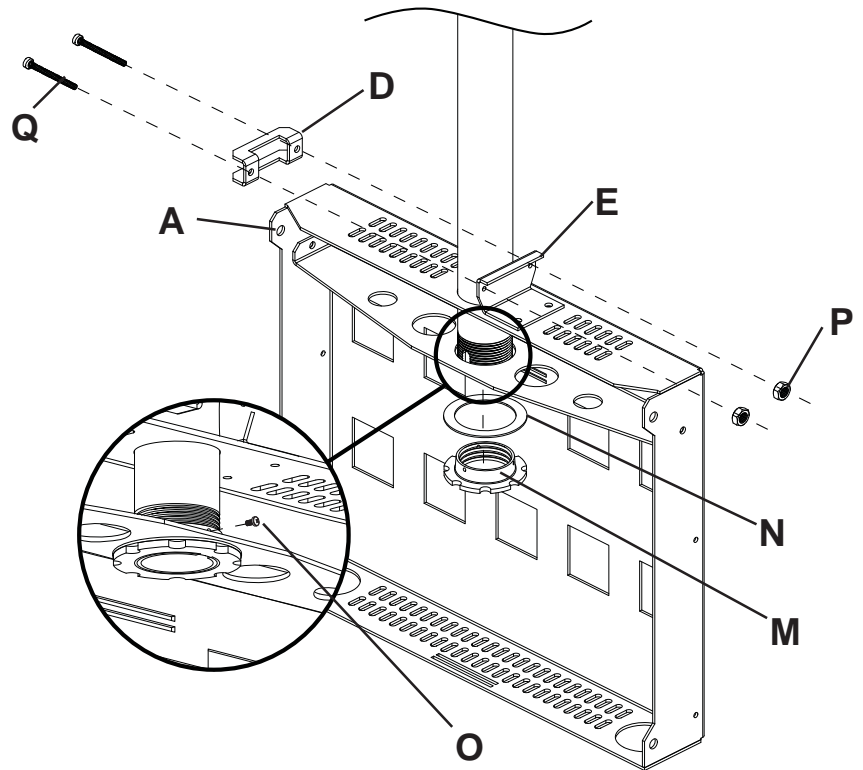
## Installing To Column

- 10** Secure yaw lock bracket (E) to main support box (A) with two M6 x 12 mm socket pin screws (F). Tighten using allen wrench (I).

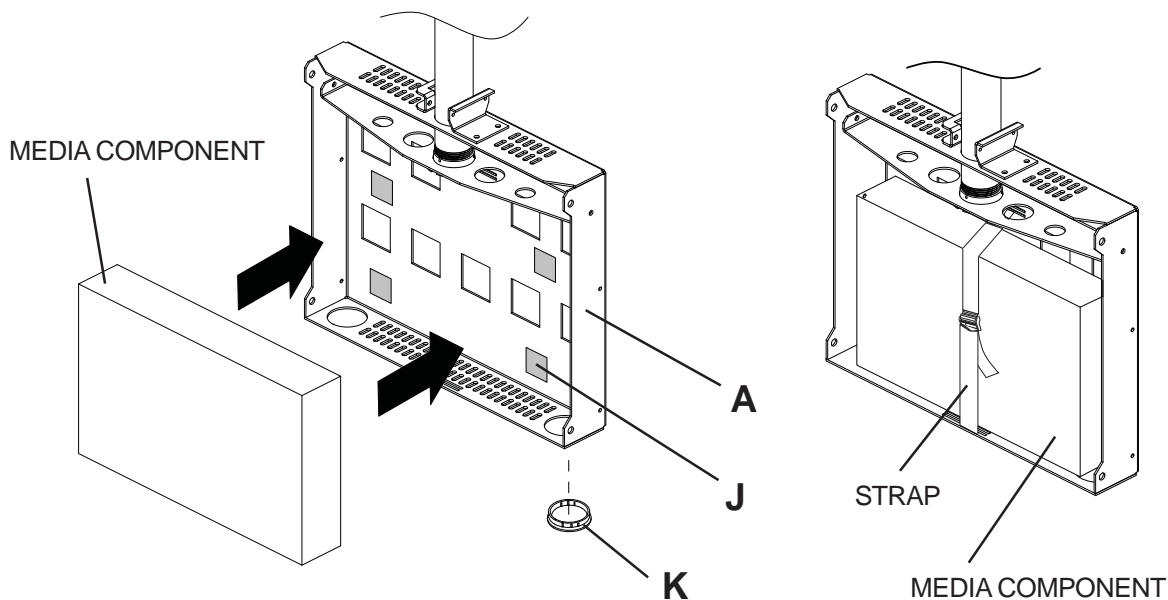


- 11** Slide tube into top of main support box (A) and secure using washer (N), retaining collar (M) and one M5 x 10 mm type F screw (O).

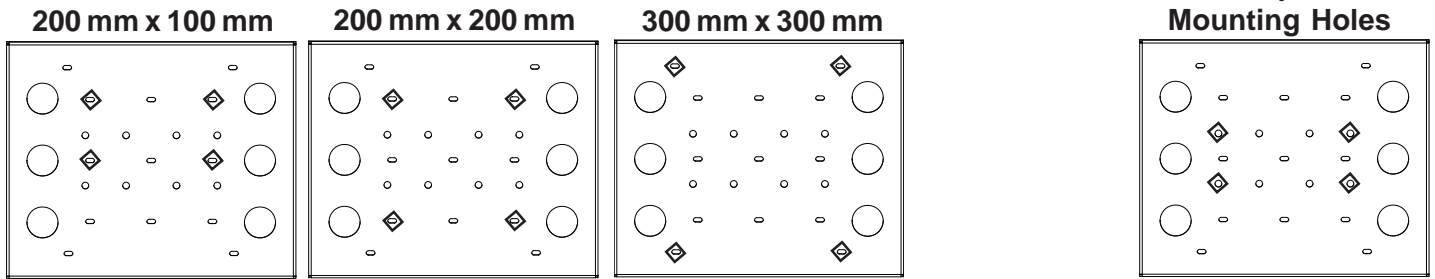
Secure main support box (A) to tube using two M5 x 55 mm socket screws (Q), pinch bracket (D), yaw lock bracket (E), and M5 nylock nut (P).



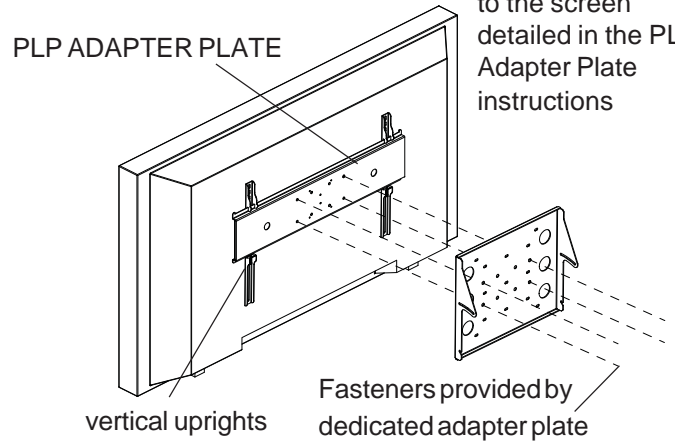
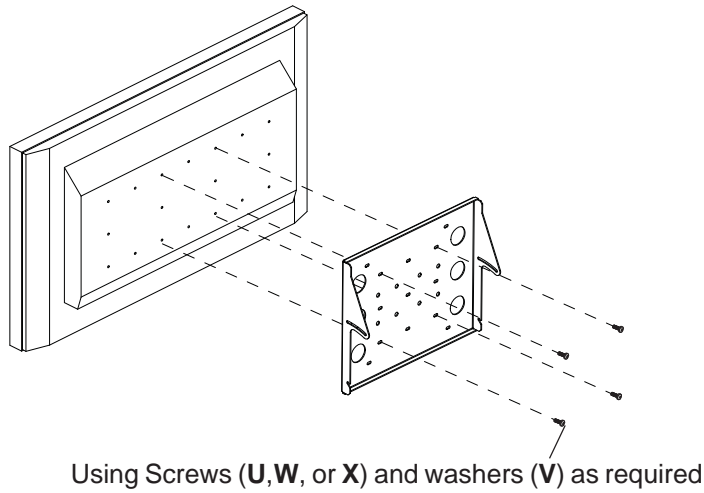
- 12** Secure media component to main support box (A) using strap provided with main support box (A), and rubber pads (J) for support and ventilation. Secure 2" snap bushing (K) as desired.



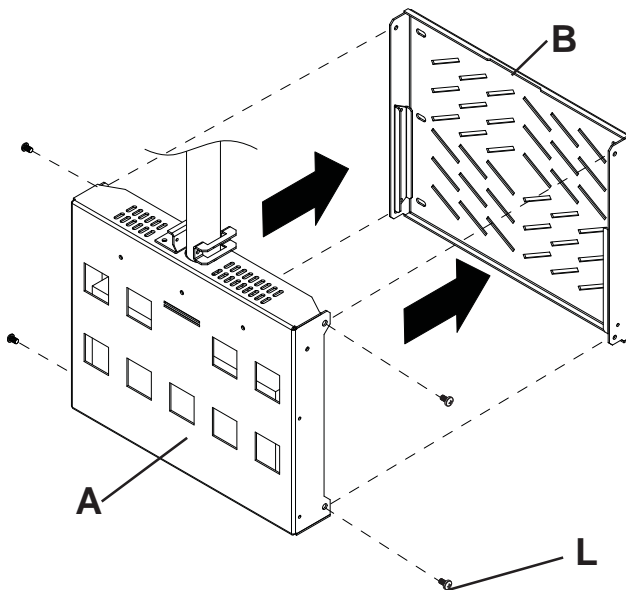
**13** Select mounting hole pattern and secure adapter plate (C) to screen using screws (U,W, or X) and washers (V) if required.



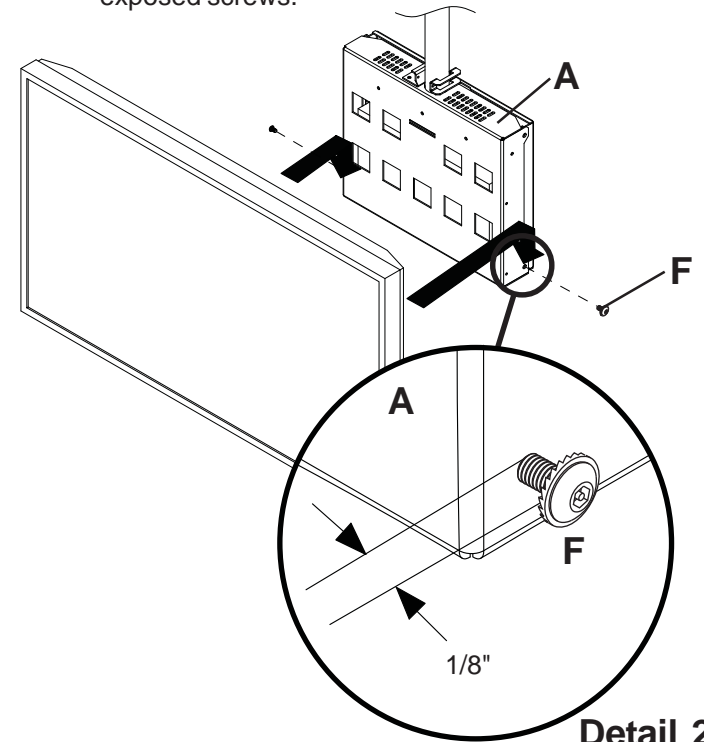
**NOTE:** First attach the vertical uprights to the screen detailed in the PLP Adapter Plate instructions



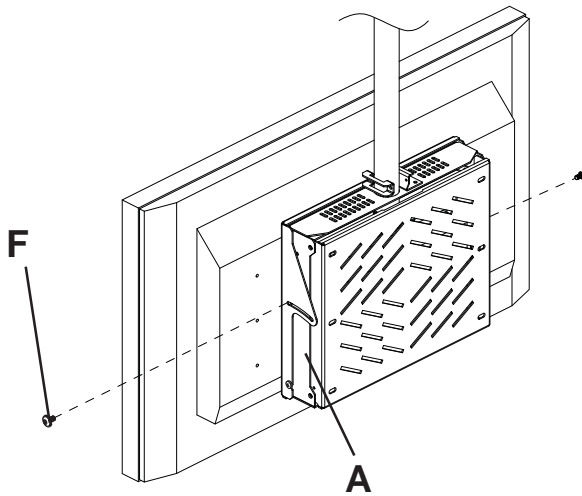
**14** Secure main support box (A) to access plate (B) using four M8 x 15 mm socket pin screws (L).



**15** Thread two M6 x 12 mm socket pin screws (F) into main support box (A) leaving 1/8" exposed thread as shown in detail 2. Hook screen and adapter plate onto exposed screws.



- 16** Secure two M6 x 12 mm socket pin screws (F) into main support box (A) at desired tilt. Tighten using allen wrench (I).



### Accessing Media Component

- 17** Loosen top two M8 x 15 mm socket pin screws (L) 1/4 turn and temporarily remove bottom two M8 x 15 mm socket pin screws (L) on main support box (A) as shown in figure 17.1. Swing screen forward and swing support brackets downward to brace screen in open position as shown in figure 17.2.

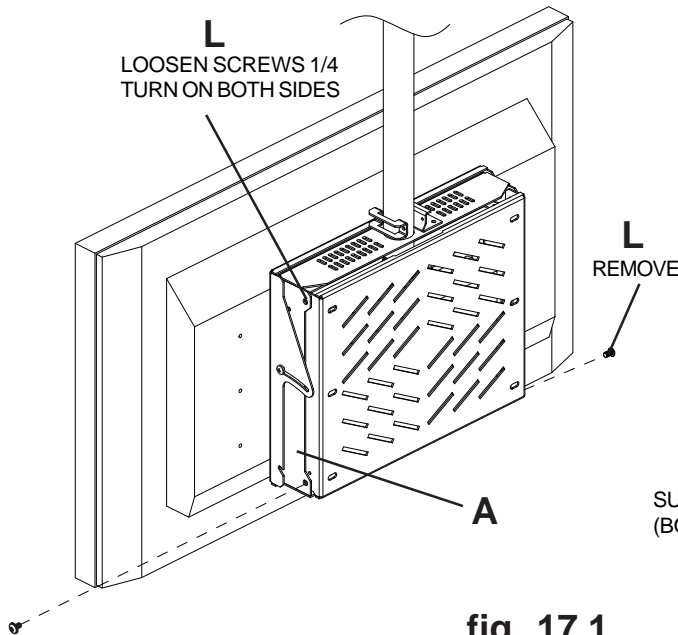


fig. 17.1

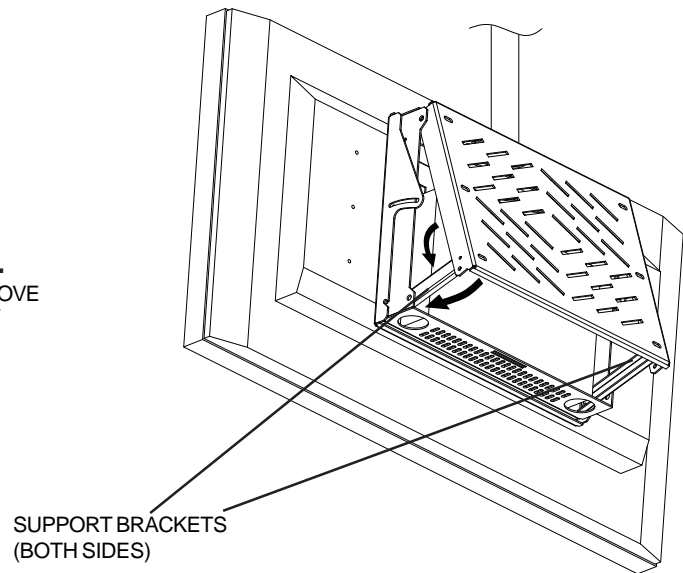


fig. 17.2