

norpole

52" Chef Base Refrigerator ♦ NPCB-52



Standard Features

- ♦ Stainless steel series 430 exterior
- ♦ Stainless steel series 304 interior
- ♦ Side mounted compressor
- ♦ Optional 3-inch legs
- ♦ LED digital temperature display
- ♦ Self contained system, simple plug installation
- ♦ Heavy-duty caster wheels

Technical Specifications

Product Classification	Refrigerator
Climate Class	N
Number of Drawers	2
External Cabinet Material	430 Stainless Steel
Internal Cabinet Material	304 Stainless Steel
Type of Refrigeration Agent	R-290
Type of Temperature Control	Digital
Temperature Range °C	0°C to 5°C
Temperature Range °F	32°F to 41°F
Voltage / Frequency	115V / 60Hz
Amp	4.5
Compressor HP	1/5
Type of Insulation	2.5-Inch Polyurethane Foam
Door Handle	Partial Length
Pan Capacity	(6) 1/1

Certified Safety Standard

- ♦ ETL Listed
- ♦ ETL Sanitation Listed



Warranty Information

- ♦ 5 Years Compressor
- ♦ 3 Year Parts & Labor





52" Chef Base Refrigerator ♦ NPCB-52

Plug Type: (NEMA) 5-15P

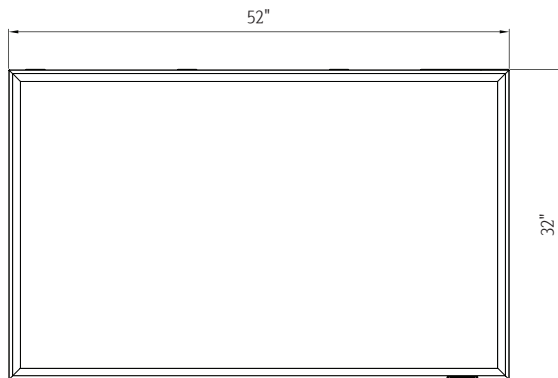

Top View

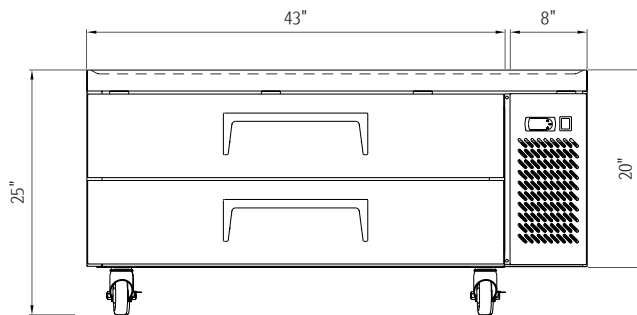

Front View

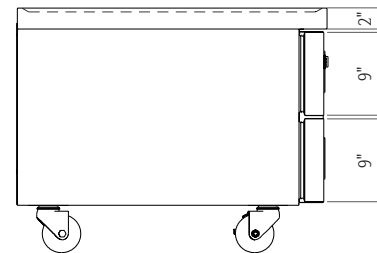

Side Section

Dimensions

External Width	52 in
External Depth	32 in
External Height	26 in
Shipping Dimensions (W x D x H)	55 x 35 x 28 in

Weight

Gross Weight	275 lbs.
--------------	----------

Capacity

Gross Capacity	11 cu. ft.
Drawers	2
Drawer Dimensions (W x D x H)	37.36 x 20 x 4 in

Accessories

Frost Free	Yes
Fixed Shelves	No
Adjustable Feet	Optional
Adjustable Thermostat	Yes