

1 Solid Door Reach-In Freezer ♦ NE19F



Standard Features

- ♦ Stainless steel series 430 exterior
- ♦ Painted aluminum interior
- ♦ Stucco aluminum back panel
- ♦ Self closing hinged doors with 90 degree stay open feature
- ♦ Bottom mounted compressor
- ♦ LED digital temperature display
- ♦ PVC coated adjustable wire shelves
- ♦ Interior lighting
- ♦ Self contained system, simple plug installation
- ♦ Heavy-duty castor wheels

Technical Specifications

Product Classification	Freezer
Climate Class	N
Number of Doors	1
External Cabinet Material	430 Stainless Steel
Internal Cabinet Material	Painted Aluminum
Type of Refrigeration Agent	R-290
Type of Temperature Control	Digital
Temperature Range °C	-22°C to -18°C
Temperature Range °F	-7°F to 0°F
Voltage / Frequency	115V / 60Hz
Amp	8.28
Compressor HP	3/4
Type of Insulation	Polyurethane
Door Handle	Partial

Certified Safety Standard

- ♦ ETL Listed
- ♦ ETL Sanitation Listed



Warranty Information

- ♦ 5 Years Compressor
- ♦ 1 Year Parts & Labor



1 Solid Door Reach-In Freezer ♦ NE19F

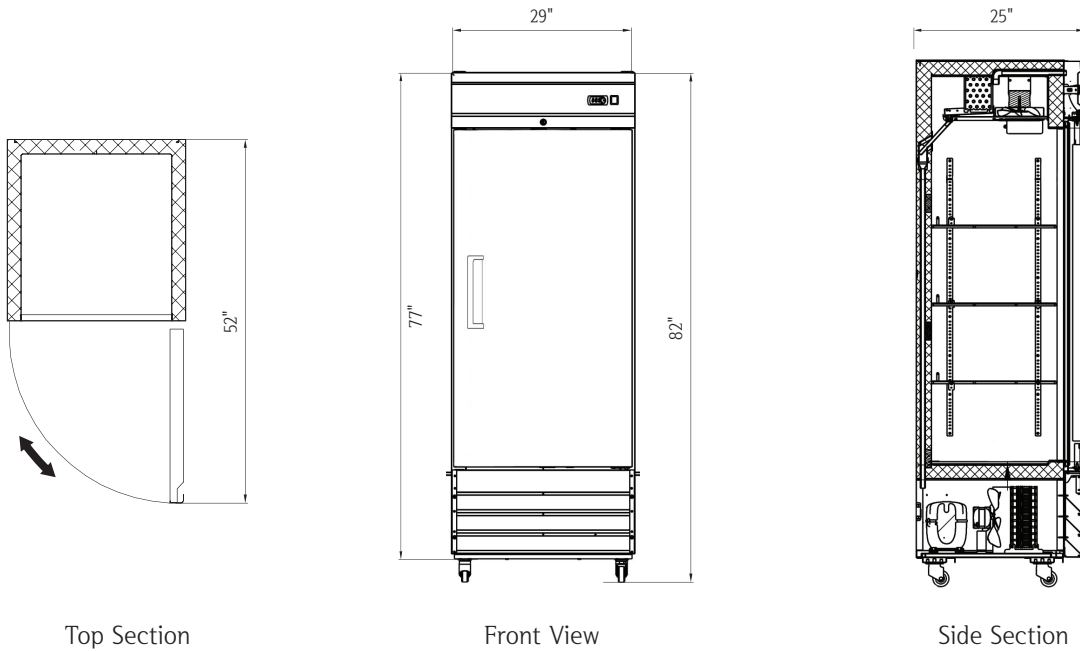

Plug Type: (NEMA) 5-15P

Capacity

Capacity 19 cu. ft.

Dimensions

Internal Cabinet Width	24 in
Internal Cabinet Depth	21 in
Internal Cabinet Height	60 in
External Width	29 in
External Depth	52 in
External Height	82 in
Shipping Dimensions (W x D x H)	31 x 27 x 83 in

Weight

Gross Weight 280 lbs.

Additional Features

Cycle Defrosting	Yes
Frost Free	Yes
Adjustable Shelves	3
Fixed Shelves	No
Internal Light	Yes
Internal Light Switch	No
Self Closing Door/Lid	Yes
Door Holder for Loading	Yes
Door/Lid Lock	Yes
Reversible (Left) Door	Yes
Adjustable Thermostat	Yes