

# Raspberry Pi Compute Module 3 - NEC Edition

## Making Digital Signage simpler and more flexible

The Raspberry Pi Compute Module 3 delivers a PC experience in the efficient system on a chip form factor built right into a NEC large format display.



NEC large format display with Interface Board and Compute Module installed

The Compute Module boosts the display performance to suit a variety of visual applications. This open-platform solution offers unrivalled flexibility and performance in creating customized display applications. Software providers and users benefit from the vast number of already available open source solutions accessible from the global Raspberry Pi developers community. The NEC edition tops the standard Raspberry Pi performance with extended memory capabilities and intelligent Digital Signage functionality supported by NEC's large format displays. The Ethernet and USB interfaces of the display allow easy integration into a network or connection with external devices such as mouse, keyboard and touch.

The Raspberry Pi Compute Module 3 is an efficient combination of computing power and cost effective hardware making it ideal for use in nearly every vertical market segment and offering the support of a robust global open-source development community.

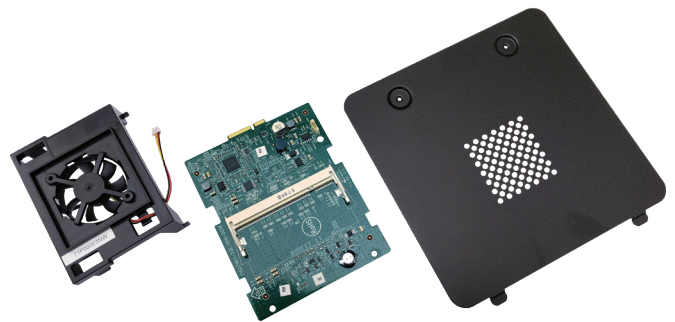

Pictured above, the compute module interface board (DS1-IF10CE) and included accessories

### Delivering Genuine Benefits

- **The power of open source design** - Adding the Raspberry Pi Compute Module 3 to a NEC Display gives users access to a robust global open source development community offering some of the most innovative and creative uses for computing.
- **Powerful possibilities** - the Quad Core 1.2 GHZ processor provides amazing performance for crisp Full HD playback with an unrivalled price-performance ratio.
- **Designed for professional Digital Signage** - The NEC Edition features 16GB of onboard memory and adds the necessary hardware decoders to meet the particular demands of professional signage applications.
- **Highly versatile** - Supporting a broad range of operating systems, this open platform offers high flexibility for digital signage software providers and system integrators.
- **Seamless** - The Compute Module is installed internally into the display for a fully integrated solution. An elegant, cable-free solution with internal connection for power, video, audio, data and all control interfaces.
- **Economical** - enjoy high performance and low energy use with associated savings.
- **High reliability** - the use of industrial grade components and our advanced heat management makes this solution ideally suited for 24/7 operation.
- **Fully integrated technology** - The internal serial connection between the display and the Raspberry Pi Compute Module allows full control and monitoring of the display from software running on the Compute Module. A Python based SDK is available for easy software development.

Technical Specifications

Raspberry Pi Compute Module 3 - NEC Edition part #	RPi3CM16GB
Interface Board part #	DS1-IF10CE

Raspberry Pi Compute Module 3 - NEC Edition	
Processor	Quad Core 64-bit ARM Cortex A53 @ 1.2GHz, VideoCore IV GPU
Graphics	Hardware video encode / decode (MPEG2, MPEG4, H.264, VC-1 up to 1080p60), 1.2GPixel / sec OpenGL ES 2.0 3D
Memory	16GByte on-board eMMC
RAM	1Gbyte LPDDR2 SDRAM
Preinstalled Operating System	Raspbian Jessie with PIXEL
Dimensions (W x H x D)	Net: 67.7 x 31 x 30mm / 2.6 x 1.2 x 1.1in
Weight	7.3g / 0.25oz
Resolution	Native resolution video (1920x1080)
Others	Includes licenses for MPEG-2, MPEG-4, and VC-1 hardware CODECs
Certificates	CE, FCC certification
Warranty	3 Years

Interface Board for Raspberry Pi Compute Module 3	
Interfaces	Connected External Display Interfaces: 3 x USB A, 1 x USB B (for programming the Compute Module) 2 x RJ45 network with internal switch, Infrared, internal serial and digital audio connection
Other features	WatchDog Timer and Realtime Clock are supported through NEC large format displays
Dimensions (W x H x D) [mm]	4.3" x 3.4" x 1.1"
Weight [g]	201.2g / 7.1oz
Certificates	CE, FCC certification
Warranty	3 Years

Internal Operation Diagrams

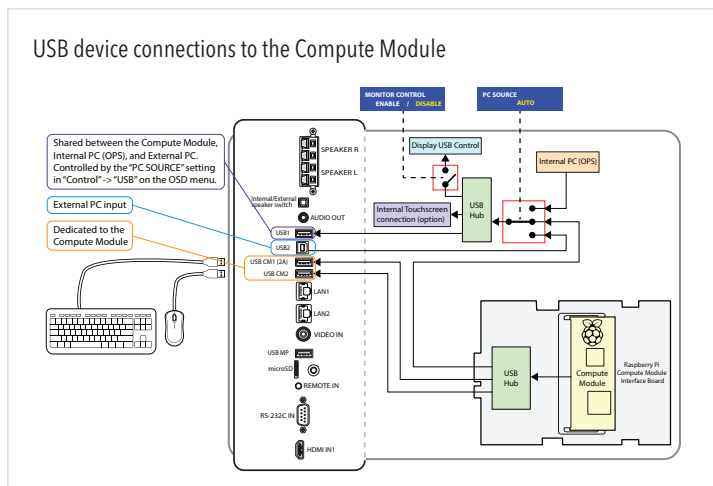
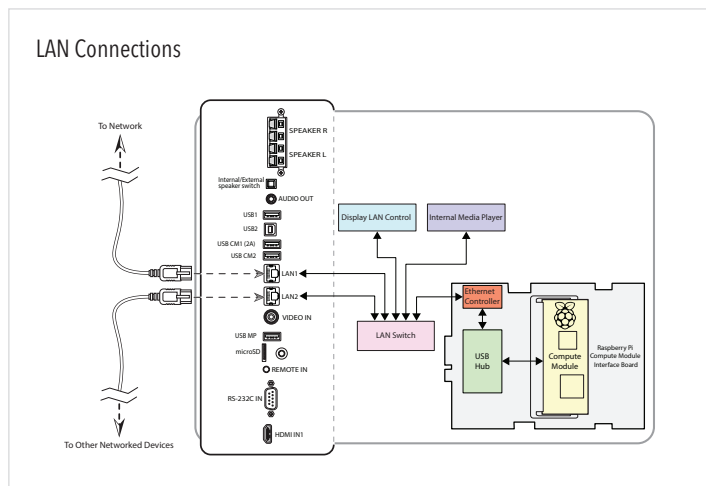

All rights are reserved in favor of their respective owners. The document, or parts thereof, should not be copied, adapted, redistributed, or otherwise used without the prior written permission of NEC Display Solutions. This document is provided "as is" without warranty of any kind whatsoever, either express or implied. Errors and omissions are excepted. NEC Display Solutions may make changes, revisions or improvements in, or discontinue the supply of any product described or referenced in this document at any time without notice.

NEC Display Solutions of America  
500 Park Blvd, Suite 1100 Itasca, Illinois 60143  
Phone: 630.467.3000 Fax: 630.467.3010

Copyright © 2017 NEC Display Solutions. All rights reserved.

25.NEC.80.GL.UN.306 | Rev. 06.08.2017

www.necdisplay.com