



CS 2082

Freestanding/Semi Built-in



LIEBHERR

Quality, Design and Innovation

This **CS 2082** offers elegant French door styling, with self-closing double freezer drawers, available in 36" for freestanding/semi built-in designs. Outstanding LED lighting can be found on the ceiling and refrigerator side walls, which double as shelf support, as well as inside the freezer drawers. Other smart interior design features include a stainless steel back wall which prevents dripping and the build-up of ice, and fully extendable SoftTelescopic freezer drawers which provide reliable self-retraction and soft closing.

The automatic IceMaker with fixed water connection produces perfect half-moon crescent ice cubes, which can be taken from freezer-to-table thanks to the removable ice bin.

Liebherr's DuoCooling system, with individual variable speed compressors, provides superior performance and efficiency, as well as advanced food preservation. The dual refrigeration system creates optimal conditions in both the refrigerator and freezer compartments, which lengthens the shelf life of foods for a healthier lifestyle. Individual silent cooling systems ensure accurate temperature and humidity controls so that your fresh foods never dry out.



Freestanding/Semi Built-in

CS 2082 PremiumPlus



Energy consumption (kWh/y)

533

Estimated Yearly Energy Cost in US \$*

64

Sound rating dB(A)**

44

Refrigerator capacity cu.ft. (l)

13.5 (382)

Freezer capacity cu.ft. (l)

6.0 (170)

Number of shelves

3

Number of door racks

6

Number of freezer drawers

2 with LED lighting

Number of fruit and vegetable drawers

3 with LED lighting

Electronic control

MagicEye with digital temp. display, touch electronic

Refrigerator temperature range °F (°C)***

+36°F to +43°F (+2°C to +6°C)

Freezer temperature range °F (°C)

+7°F to -17°F (-14°C to -27°C)

Defrost type

automatic

Interior light

LED light column and LED ceiling lighting

Water filter

yes

IceMaker

fixed water connection

Ice cube output lbs. (kg)/24h

3.1 (1.4)

Ice cube stock lbs. (kg)

7.9 (3.6)

Door hinges

left/right

Product dimensions (H/W/D) in. (cm)

80 5/16" / 35 7/8" / 24 1/4" (203.9/91/61.5)

Cut out dimensions (H/W/D) in. (cm)

80 9/16" / 36 1/16" / 24 1/16" (204.5/91.5/61)

Net weight lbs. (kg)

374.8 (170.0)

Voltage V/Hz

115/60

* Estimated energy cost will depend on utility rates and use. Estimated energy cost based on a national average electricity cost of 12 cents per kWh.

** Noise output – according to EN 60704-3.



German Engineering: Our superior products offer premium quality, cutting edge design, and innovative features that best fit your lifestyle. The use of high quality materials, perfectly detailed finishes, and elite cooling components are combined with the latest production processes, resulting in an outstanding cooling product.



Energy Star: The entire line of North American Liebherr appliances meet or exceed ENERGY STAR® rating requirements, greatly reducing greenhouse emissions and energy costs.



DuoCooling

DuoCooling: The dual refrigeration system creates optimal conditions in both the refrigerator and freezer which lengthens the shelf life of food items for a healthier lifestyle. This technology also preserves the flavor and texture of foods since there is no transfer of unwanted air, moisture or food aroma between the two compartments.



SuperCool/SuperFrost: Simply quick chill and/or freeze fresh groceries to preserve optimum freshness and seal in flavors, textures as well as maintain essential vitamins and minerals.



SuperQuiet

SuperQuiet: Noise levels are kept to a minimum thanks to virtually silent, speed-controlled, and sound absorbing compressors. Alongside a low noise cooling circuit, these features ensure exact performance, energy efficiency, and SuperQuiet operation.



Electronic Control

Electronic Display: Our intuitive electronic touch control panel ensures all functions are easy and convenient to use as well as guarantees that the settings selected remain accurate and constant.



GlassLine

GlassLine: The elegant yet tough GlassLine shelves are scratch resistant and easy to clean as well as dishwasher safe. The space-saving shelves are designed for organization and are completely adjustable to suit your needs and the contents of the refrigerator. Additionally, the lighting shines through for a brighter interior.



LED

LED: Distinctive LED light columns are integrated into both sides of the compartment liner. Inside the columns are numerous cool LED lights that ensure uniform lighting throughout the interior.



Gallon Storage on door: A Liebherr is designed to fit more cubic feet of your everyday life. The durable yet elegant GlassLine door racks easily accommodate a large supply of milk or juice on hand.

Unit Dimensions

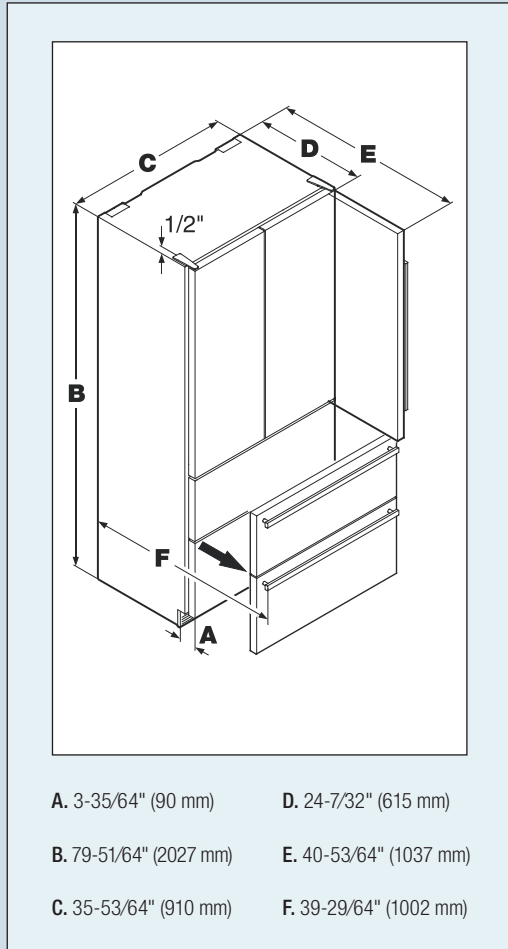

Top Door Hinge Clearance

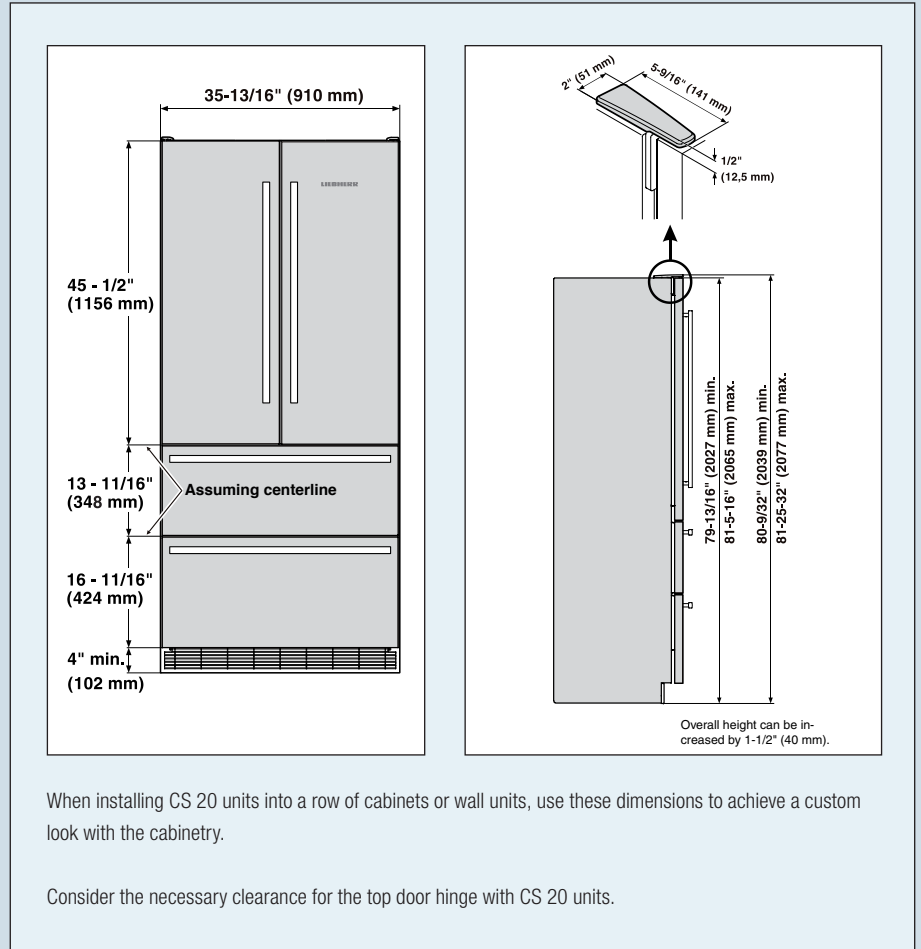

Cabinet Opening Dimensions

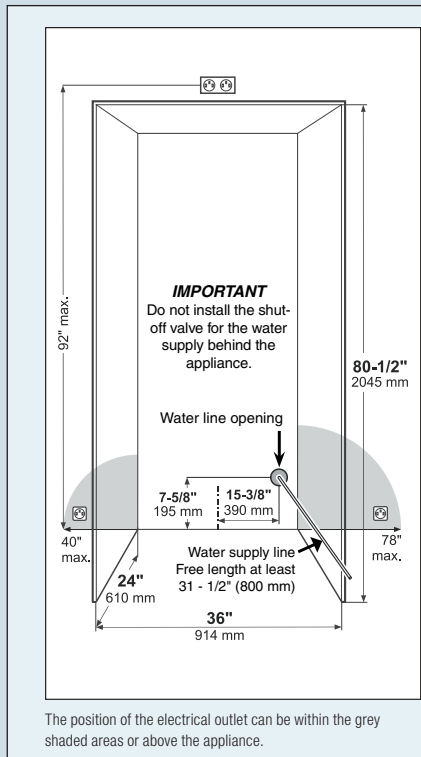

The appliance can be used freestanding or semi built-in. If semi built-in, consider the cabinet opening dimensions specified below.

Minimum opening height for the **french door** 36" model (CS 2062) is **80-1/2"** to accommodate the top mounted hinges.

The requirements for water supply and electrical outlet are the same for both applications.

IMPORTANT
With 24" depth cabinets, the water line opening must be in the location as shown as there will not be room to route a water line behind the appliance for risk of pinching. Also, for this cabinet depth the electrical outlet cannot be behind the unit or the unit will not be able to be pushed all the way back into the opening. With cabinets deeper than 24" there is room to fit the pipe behind the appliance and the wall so there are no requirements for the water line lead out position.

Ventilation Requirements

