



KRAMER ELECTRONICS LTD.

USER MANUAL

MODEL:

VM-114H2C

2 Input 1:4 HDMI DA/2x CAT5
Outputs

P/N: 2900-000644 Rev 8



VM-114H2C Quick Start Guide

This guide helps you install and use your product for the first time. For more detailed information, go to http://www.kramerelectronics.com/support/product_downloads.asp to download the latest manual or scan the QR code on the left.

Step 1: Check what's in the box

- ✓ **VM-114H2C** 2 Input 1:4 HDMI DA/
2x CAT5 Outputs
- ✓ 1 Power supply (12V DC)
- ✓ 4 Rubber feet
- ✓ 1 Quick Start sheet
- ✓ Kramer **RC-IR3** Infrared Remote
Control Transmitter with batteries
and user manual

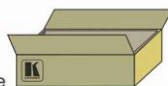

Save the original box and packaging materials in case you need to return your **VM-114H2C** for service.

Step 2: Install the VM-114H2C

Attach the rubber feet and place on a table or mount the **VM-114H2C** in a rack (using an optional **RK-1** rack mount).

Step 3: Connect the inputs and outputs

Always switch off the power on each device before connecting it to your **VM-114H2C**.

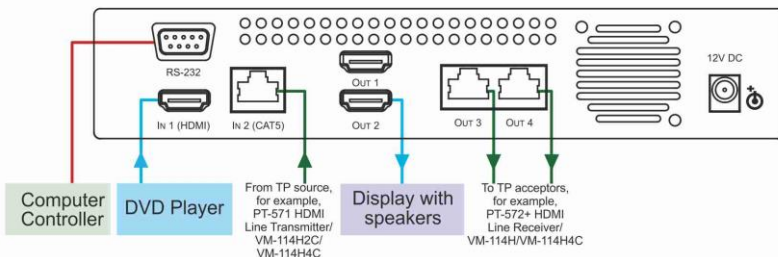

Always use Kramer high-performance cables for connecting AV equipment to the **VM-114H2C**.

Step 4: Connect the power

Connect the 12V DC power adapter to the **VM-114H2C** and plug the adapter into the mains electricity.



Step 5: Operate the VM-114H2C

Acquire the EDID from a connected output.

1. Press the EDID SELECT button to cycle through the EDID sources in the following order:
 - Output 1 (Output 1 LED lights)
 - Output 2 (Output 2 LED lights)
 - Output 3 (Output 3 LED lights)
 - Output 4 (Output 4 LED lights)
 - Default EDID (all LEDs light)
 - Auto-Mix EDID (the LEDs flash in a running sequence)
2. To store the EDID, press EDID READ and the EDID is acquired.

Contents

1	Introduction	1
2	Getting Started	2
2.1	Achieving the Best Performance	2
2.2	Safety Instructions	3
2.3	Recycling Kramer Products	3
3	Overview	4
3.1	Using Twisted Pair Cable	5
3.2	About the Power Connect™ Feature	5
3.3	Defining the VM-114H2C	5
4	Connecting the VM-114H2C	7
4.1	Connecting to the VM-114H2C via RS-232	8
5	Operating the VM-114H2C	9
5.1	Acquiring the EDID	9
5.2	Disabling/Enabling Deep Color Support	10
5.3	RS-232 and IR Control and Pass-Through	10
6	Wiring the Twisted Pair RJ-45 Connectors	15
7	Technical Specifications	16
8	Default Communication Parameters	17
9	Default EDID	18
10	Protocol 2000	19
10.1	Syntax	19

Figures

Figure 1:	VM-114H2C 2 Input 1:4 HDMI DA/2x CAT5 Outputs	5
Figure 2:	Connecting the VM-114H2C 2 Input 1:4 HDMI DA/2x CAT5 Outputs	8
Figure 3:	VM-114H2C RS-232 Control and Pass-Through	11
Figure 4:	VM-114H2C IR Control and Pass-Through Example 1	12
Figure 5:	VM-114H2C IR Control and Pass-Through Example 2	13
Figure 6:	VM-114H2C IR Control and Pass-Through Example 3	14
Figure 7:	TP Pinout Wiring	15

1 Introduction

Welcome to Kramer Electronics! Since 1981, Kramer Electronics has been providing a world of unique, creative, and affordable solutions to the vast range of problems that confront video, audio, presentation, and broadcasting professionals on a daily basis. In recent years, we have redesigned and upgraded most of our line, making the best even better!

Our 1,000-plus different models now appear in 11 groups that are clearly defined by function: GROUP 1: Distribution Amplifiers; GROUP 2: Switchers and Routers; GROUP 3: Control Systems; GROUP 4: Format/Standards Converters; GROUP 5: Range Extenders and Repeaters; GROUP 6: Specialty AV Products; GROUP 7: Scan Converters and Scalers; GROUP 8: Cables and Connectors; GROUP 9: Room Connectivity; GROUP 10: Accessories and Rack Adapters and GROUP 11: Sierra Products.

Congratulations on purchasing your Kramer **VM-114H2C 2 Input 1:4 HDMI DA/ 2x CAT5 Outputs**, which is ideal for the following typical applications:

- Home theater, presentation and multimedia applications
- Rental and staging

2 Getting Started

We recommend that you:

- Unpack the equipment carefully and save the original box and packaging materials for possible future shipment
- Review the contents of this user manual



Go to http://www.kramerelectronics.com/support/product_downloads.asp to check for up-to-date user manuals, application programs, and to check if firmware upgrades are available (where appropriate).

2.1 Achieving the Best Performance

To achieve the best performance:

- Use only good quality connection cables (we recommend Kramer high-performance, high-resolution cables) to avoid interference, deterioration in signal quality due to poor matching, and elevated noise levels (often associated with low quality cables)
- Do not secure the cables in tight bundles or roll the slack into tight coils
- Avoid interference from neighboring electrical appliances that may adversely influence signal quality
- Position your Kramer **VM-114H2C** away from moisture, excessive sunlight and dust



This equipment is to be used only inside a building. It may only be connected to other equipment that is installed inside a building.

2.2 Safety Instructions



Caution: There are no operator serviceable parts inside the unit

Warning: Use only the Kramer Electronics input power wall adapter that is provided with the unit

Warning: Disconnect the power and unplug the unit from the wall before installing

2.3 Recycling Kramer Products

The Waste Electrical and Electronic Equipment (WEEE) Directive 2002/96/EC aims to reduce the amount of WEEE sent for disposal to landfill or incineration by requiring it to be collected and recycled. To comply with the WEEE Directive, Kramer Electronics has made arrangements with the European Advanced Recycling Network (EARN) and will cover any costs of treatment, recycling and recovery of waste Kramer Electronics branded equipment on arrival at the EARN facility. For details of Kramer's recycling arrangements in your particular country go to our recycling pages at <http://www.kramerelectronics.com/support/recycling/>.

3 Overview

The **VM-114H2C 2 Input 1:4 HDMI DA/2x CAT5 Outputs** is a switcher/distribution amplifier for HDMI and TP (twisted pair) signals. It reclocks and equalizes one of two selectable input signals and distributes it to two HDMI and two TP outputs.

In particular, the **VM-114H2C** features:

- A maximum data rate of 4.95Gbps (1.65Gbps per graphic channel), 6.75Gbps (2.25Gbps per graphic channel) maximum when using HDMI only
- Non-volatile memory that reads and stores the default EDID or the EDID block from one or a mix of the output display devices, so it can then provide the EDID information to the source even if the display device is not connected
- I-EDIDPro™ Kramer Intelligent EDID Processing™, an intelligent EDID handling & processing algorithm that ensures Plug and Play operation for HDMI systems
- HDMI support for 3D, Deep Color, x.v.Color™ and 7.1 uncompressed audio channels (Dolby TrueHD, DTS-HD)
- HDCP compliance
- LEDs indicating the selected input and active output
- IR remote control support and has a remote IR 3.5mm mini jack
- 12V DC power
- Housing in a Kramer desktop enclosure

The **VM-114H2C** supports a range of:

- Up to 90m (295ft) at 1080i, or up to 30m (98ft) at 1080p on shielded **BC-DGKat524** cable
- Up to 90m (295ft) at 1080i, or up to 70m (230ft) at 1080p on shielded **BC-DGKat623** cable
- Up to 100m (330ft) at 1080i or up to 90m (295ft) at 1080p on shielded **BC-DGKat7a23** cable

3.1 Using Twisted Pair Cable

Kramer engineers have developed special twisted pair cables to best match our digital twisted pair products; the Kramer: **BC-DGKat524** (CAT 5 24 AWG), the Kramer: **BC-DGKat623** (CAT 6 23 AWG cable), and the Kramer: **BC-DGKat7a23** (CAT 7a 23 AWG cable). These specially built cables significantly outperform regular CAT 5 / CAT 6 / CAT 7a cables.

3.2 About the Power Connect™ Feature

The Power Connect™ feature here means that only one unit in a system, the transmitter or receiver, needs to be connected to a power source when the devices are within 60m (197ft) of each other. The Power Connect™ feature applies as long as the cable can carry power and the distance does not exceed 60m on standard TP cable. (Heavier gauge cable may be used to extend the Power Connect™ range).

3.3 Defining the VM-114H2C

This section defines the **VM-114H2C**.

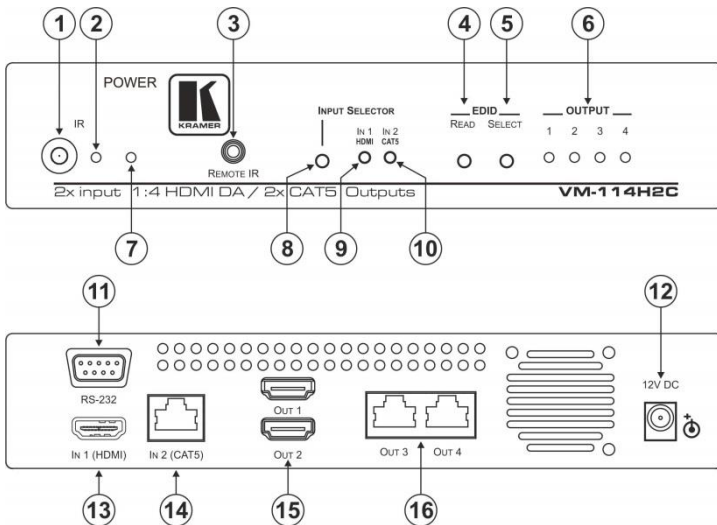

Figure 1: VM-114H2C 2 Input 1:4 HDMI DA/2x CAT5 Outputs

#	Feature		Function
1	IR Remote Control Sensor		Sensor for the remote control IR transmitter
2	IR LED		Lights yellow when receiving signals from the IR remote control transmitter
3	REMOTE IR 3.5mm Mini Jack		Connect to a remote IR sensor
4	EDID Buttons	READ Button	Press (when one of the input LEDs is flashing to indicate a selected input) to read the selected EDID (see Section 5.1)
5		SELECT Button	Press repeatedly to cycle through the inputs to select an input from which to read the EDID. The relevant LED flashes (see Section 5.1)
6	OUTPUT 1~4 LEDS		The relevant LED lights green when an acceptor is connected to the output Also lights or flashes during EDID setup (see Section 5.2)
7	POWER LED		Lights green when the unit receives power
8	INPUT SELECTOR Button		Press to select an input. The relevant IN 1 HDMI/IN 2 CAT5 LED lights
9	IN1 HDMI LED	Input LEDs	Lights green when HDMI input 1 is selected
10	IN2 CAT5 LED		Lights green when the TP CAT 5 input 2 is selected
11	RS-232 9-pin D-sub (F) Connector		Connect to a PC or remote controller
12	12V DC Power Connector		Connect to the +12V DC power adapter, center pin positive
13	IN1 (HDMI) Input HDMI Connector	Inputs	Connect to an HDMI source
14	IN2 (CAT5) Input RJ-45 Connector		Connect to a TP source (for example, PT-571 HDMI Line Transmitter, VM-114H2C or VM-114H4C)
15	OUT 1	HDMI Output Connectors	Connect to the HDMI acceptors
	OUT 2		
16	OUT 3	TP RJ-45 Output Connectors	Connect to the TP acceptors (for example, PT-572+ HDMI Line Receiver, VM-114H or VM-114H4C)
	OUT 4		

4 Connecting the VM-114H2C



Always switch off the power to each device before connecting it to your **VM-114H2C**. After connecting your **VM-114H2C**, connect its power and then switch on the power to each device.

To connect the **VM-114H2C** as illustrated in the example in [Figure 2](#):

1. Connect the HDMI source (for example, a DVD player) to the IN 1 (HDMI) connector.
2. Connect the TP source, for example, a **PT-571 HDMI Line Transmitter** (another example is the **TP-573**), another **VM-114H2C** or a **VM-114H4C** to the IN 2 (CAT5) connector.
3. Connect the HDMI OUT connectors to up to two HDMI acceptors, for example, LCD TV or plasma displays
4. Connect the TP RJ-45 output connectors to up to two TP acceptors, for example, the **PT-572+ HDMI Line Receiver** (another example is the **TP-574**), the **VM-114H** or the **VM-114H4C**.
5. Optional—Plug the remote IR sensor into the front panel remote IR 3.5mm mini jack.
6. Optional—Connect a PC via RS-232 to the RS-232 port on the **VM-114H2C** (see [Section 4.1](#)).
7. Connect the power adapter to the power socket on the **VM-114H2C** and to the mains electricity (not shown in [Figure 2](#)).
8. Optional—Press the EDID READ button to acquire or change the EDID information (see [Section 5.1](#)).

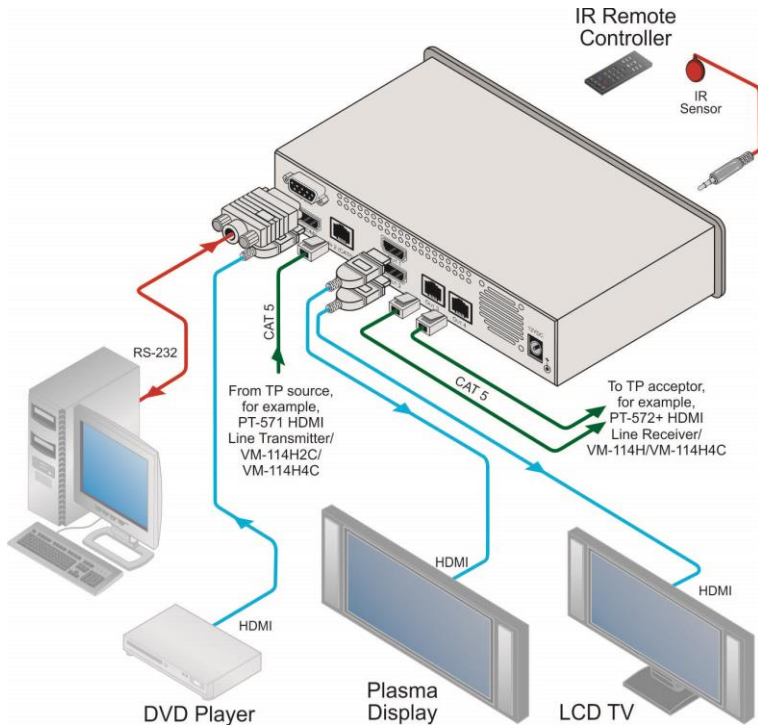

Figure 2: Connecting the VM-114H2C 2 Input 1:4 HDMI DA/2x CAT5 Outputs

4.1 Connecting to the VM-114H2C via RS-232

You can connect to the **VM-114H2C** via an RS-232 connection using, for example, a PC. Note that a null-modem adapter/connection is not required.

To connect to the **VM-114H2C** via RS-232:

- Connect the RS-232 9-pin D-sub rear panel port on the **VM-114H2C** unit via a 9-wire straight cable (only pin 2 to pin 2, pin 3 to pin 3, and pin 5 to pin 5 need to be connected) to the RS-232 9-pin D-sub port on your PC

5 Operating the VM-114H2C

This section describes how to use the **VM-114H2C**.

5.1 Acquiring the EDID

Each input on the **VM-114H2C** has a factory default EDID loaded (see [Section 9](#)).

This lets you connect the power before having to connect one of the acceptors.

The VM-114H2C reads the EDID, which is stored in the non-volatile memory.

You can acquire the EDID from:

This is usually done only once, when the machine is being set up in an installation. Once acquired, the EDID is saved in non-volatile memory and further acquisition is not necessary.

- One output (the relevant output LED flashes)
- The default EDID (all output LEDs flash)
- Up to four connected outputs using the Auto-mix Mode (all output LEDs light)

The EDID acquired is a weighted average of all the connected outputs. For example, if several displays with different resolutions are connected to the outputs, the acquired EDID supports all the resolutions, as well as other parameters included in the EDID

To acquire the EDID:

1. Connect the output(s) from which you want to acquire the EDID.
2. Press the EDID SELECT button briefly.
The device enters the EDID programming mode. The last acquired EDID is indicated by the lit LED (for example, if Output LED 2 is lit, the EDID acquired was from Output 2).
3. Press the EDID SELECT button repeatedly until the required EDID is indicated based on the patterns described above.
4. Press the EDID READ button.

The relevant LEDs flash in a pattern for a few seconds as follows:

- Slowly and then no longer lights. The EDID was successfully read.
- Quickly and then no longer lights. The EDID was not read and the default EDID was stored.

5.2 Disabling/Enabling Deep Color Support

You can disable EDID deep color support to prevent signal deterioration when using long twisted pair cables on INPUT 2.

To disable deep color and acquire EDID:

1. Disconnect the power.
2. Connect the output or outputs from which you want to acquire the EDID.
3. Connect the power while pressing the EDID READ button.
4. Perform steps 3 and 4 in [Section 5.1](#).

To enable deep color and acquire EDID:

1. Disconnect the power.
2. Connect the output or outputs from which you want to acquire the EDID.
3. Connect the power while pressing the EDID SELECT button.
4. Perform steps 3 and 4 in [Section 5.1](#).

5.3 RS-232 and IR Control and Pass-Through

The **VM-114H2C** can be controlled via RS-232 and infrared. Depending on how the RS-232 and IR connections are configured, the device either responds to control signals or transparently passes them through to another receiver or transmitter. Three examples in [Sections 5.3.3](#), [5.3.4](#) and [5.3.5](#) of various configurations illustrate this functionality.

5.3.1 RS-232 Control and Pass-Through Using the VM-114H2C

As shown in [Figure 3](#), you can connect a PC (or other serial controller) directly to the **VM-114H2C** to control the **VM-114H2C**.

The **VM-114H2C** also transparently passes bidirectional RS-232 signals over the TP cable from the **TP-573** transmitter to the **TP-574** receiver. For example, a PC connected to the RS-232 port on the **TP-573** can control an RS-232-controllable device (for example, a projection screen) connected to the **TP-574**.

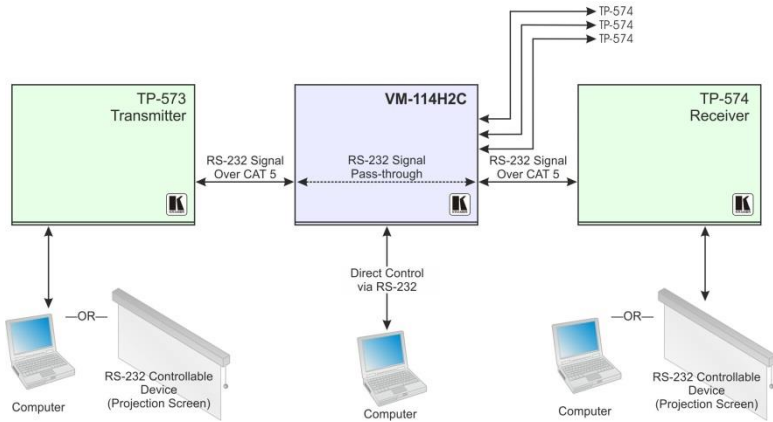

Figure 3: VM-114H2C RS-232 Control and Pass-Through

5.3.2 Local IR Control and IR Pass-Through Using the VM-114H2C

The **VM-114H2C** provides an IR sensor and a 3.5mm mini jack for connecting a remote IR emitter or sensor. When the **VM-114H2C** is connected to suitable transmitters and receivers (for example, the **TP-573** and **TP-574**), the **VM-114H2C** can act as a pass-through for IR control signals, allowing remote control of multiple devices using multiple IR remote controllers.

When there is no IR sensor or emitter connected to the IR remote 3.5mm mini jack, all signals received by the IR sensor on the front panel are passed to the transmitter and receiver bi-directionally over the TP cable allowing control of remote devices.

When an IR sensor or emitter is connected to the IR remote 3.5mm mini jack, the connection between the IR sensor on the front panel and the IR on the transmitter/receiver is broken so that any signal received by the IR sensor on the front panel remains local to the **VM-114H2C** and controls only the **VM-114H2C**.

To control any device you need to use the appropriate IR remote controller, for example, the Kramer remote controller controls Kramer devices, the LCD remote controller controls the LCD display and so on, as shown in the following examples.

The following examples illustrate just three of the possible ways of connecting the **VM-114H2C** to provide local and remote IR control.

5.3.3 IR Local Control and Pass-Through Example 1

The configuration is shown in [Figure 4](#).

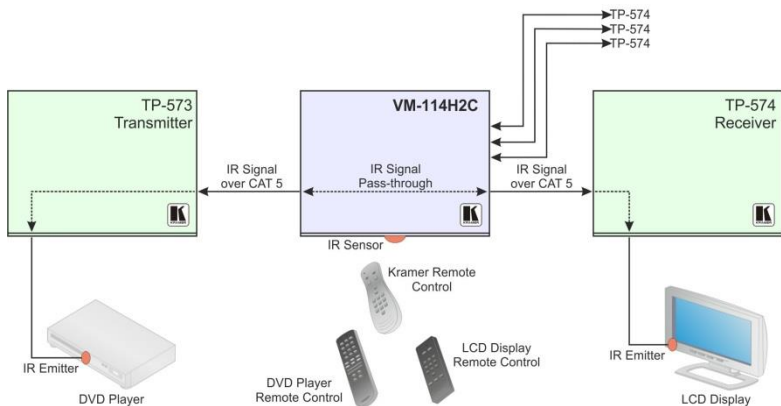

Figure 4: VM-114H2C IR Control and Pass-Through Example 1

- A DVD player is connected to the **TP-573** transmitter via an IR emitter.
- An LCD display is connected to the **TP-574** receiver via an IR emitter.
- Both the **TP-573** and the **TP-574** are connected to the **VM-114H2C** via TP cabling.

Point the appropriate remote control for the device at the **VM-114H2C** IR sensor to control a device.

5.3.4 IR Local Control and Pass-Through Example 2

The configuration is shown in [Figure 5](#).

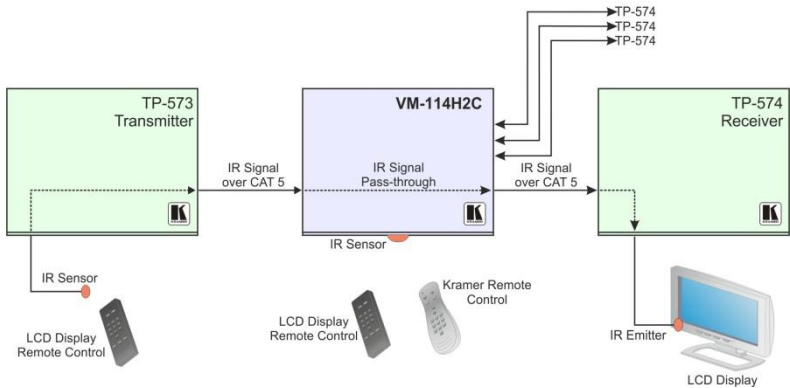

Figure 5: VM-114H2C IR Control and Pass-Through Example 2

- An IR sensor is connected to the **TP-573** transmitter.
- An LCD display is connected to the **TP-574** receiver via an IR emitter.
- Both the **TP-573** and the **TP-574** are connected to the **VM-114H2C** via TP cabling.

Point the LCD display remote control either at the **TP-573** IR sensor or at the **VM-114H2C** IR sensor to control the LCD display. Point the Kramer remote control at the **VM-114H2C** IR sensor to control the **VM-114H2C**.

5.3.5 IR Local Control and Pass-Through Example 3

The configuration is shown in [Figure 6](#).

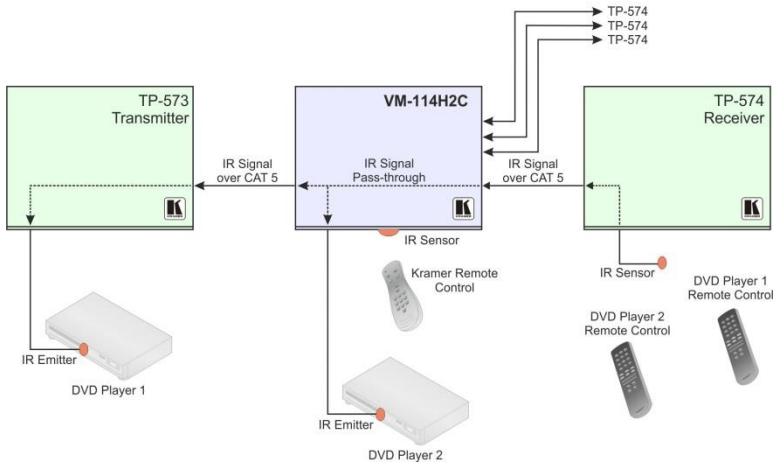

Figure 6: VM-114H2C IR Control and Pass-Through Example 3

- The first DVD player (player 1) is connected to the **TP-573** transmitter via an IR emitter.
- The second DVD player (player 2) is connected to the **VM-114H2C** via an IR emitter.
- An IR sensor is connected to the **TP-574** receiver.
- Both the **TP-573** and the **TP-574** are connected to the **VM-114H2C** via TP cabling.

To control DVD player 1, point the DVD player 1 IR remote control at the **TP-574** IR sensor. To control DVD player 2, point the DVD player 2 IR remote control at the **TP-574** IR sensor. Point the Kramer remote control at the **VM-114H2C** IR sensor to control the **VM-114H2C**.

6 Wiring the Twisted Pair RJ-45 Connectors

When using STP cable, connect/solder the cable shield to the RJ-45 connector shield. [Figure 7](#) defines the TP pinout using a straight pin-to-pin cable with RJ-45 connectors.



Note, you must connect/solder the cable ground shielding to the connector shield.

EIA /TIA 568B	
PIN	Wire Color
1	Orange / White
2	Orange
3	Green / White
4	Blue
5	Blue / White
6	Green
7	Brown / White
8	Brown
<hr/>	
Pair 1	4 and 5
Pair 2	1 and 2
Pair 3	3 and 6
Pair 4	7 and 8

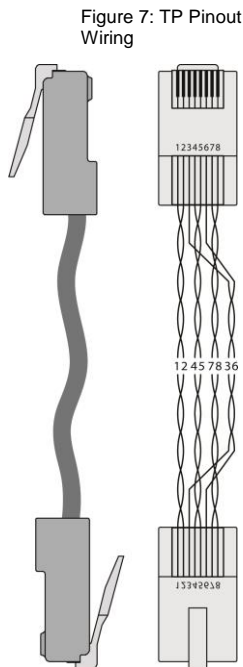

7 Technical Specifications

INPUTS:	1 HDMI connector 1 twisted pair on an RJ-45 connector
OUTPUTS:	2 HDMI connectors 2 twisted pair on RJ-45 connectors
MAX.DATA RATE:	6.75 (2.25Gbps per graphic channel, HDMI), 4.95Gbps (1.65Gbps per graphic channel, DGMAT)
COMPLIANCE WITH HDMI STANDARD:	Supports HDMI and HDCP
CONTROLS:	Input select button, EDID select button, panel lock button, RS-232, local and remote IR controls
INDICATOR LEDs:	IR communication, Power, IN 1 HDMI, IN 2 CAT5, OUTPUT 1, 2, 3 and 4
POWER CONSUMPTION:	12V DC, 1.4A
OPERATING TEMPERATURE:	0° to +40°C (32° to 104°F)
STORAGE TEMPERATURE:	-40° to +70°C (-40° to 158°F)
HUMIDITY:	10% to 90%, RHL non-condensing
DIMENSIONS:	21.5cm x 16.3cm x 4.4cm (8.5in x 6.4in x 1.7in) W, D, H
WEIGHT:	0.9kg (1.98lbs) approx.
ACCESSORIES:	Power supply, RC-IR3 infrared remote control transmitter
OPTIONS:	RK-1 19" rack adapter
Specifications are subject to change without notice at http://www.kramerelectronics.com	

8 Default Communication Parameters

The following table lists the default communication parameters for the **VM-114H2C**.

RS-232	
Protocol 2000	
Baud Rate:	9600
Data Bits:	8
Stop Bits:	1
Parity:	None
Command Format:	HEX
Example (Output 1 to Input 1):	0x01, 0x81, 0x81, 0x81

9 Default EDID

The factory default EDID is listed below.

```
Monitor
Model name          VM114H2C
Manufacturer        KRM
Plug and Play ID    KRM0114
Serial number       505-707455010
Manufacture date    2009, ISO week 10
-----
EDID revision       1.3
Input signal type   Digital
Color bit depth     Undefined
Display type        RGB color
Screen size         520 x 320 mm (24.0 in)
Power management    Standby, Suspend, Active off/sleep
Extension blocs     1 (CEA-EXT)
-----
DDC/CI              n/a

Color characteristics
Default color space Non-sRGB
Display gamma       2.20
Red chromaticity    Rx 0.674 - Ry 0.319
Green chromaticity  Gx 0.188 - Gy 0.706
Blue chromaticity   Bx 0.148 - By 0.064
White point (default) Wx 0.313 - Wy 0.329
Additional descriptors None

Timing characteristics
Horizontal scan range 30-83kHz
Vertical scan range   56-76Hz
Video bandwidth       170MHz
CVT standard          Not supported
GTF standard          Not supported
Additional descriptors None
Preferred timing      Yes
Native/preferred timing 1280x720p at 60Hz (16:10)
Modeline              "1280x720" 74.250 1280 1390 1430 1650 720 725 730 750 +hsync +vsync

Standard timings supported
720 x 400p at 70Hz - IBM VGA
640 x 480p at 60Hz - IBM VGA
640 x 480p at 75Hz - VESA
800 x 600p at 60Hz - VESA
800 x 600p at 75Hz - VESA
1024 x 768p at 60Hz - VESA
1024 x 768p at 75Hz - VESA
1280 x 1024p at 75Hz - VESA
1280 x 1024p at 60Hz - VESA STD
1600 x 1200p at 60Hz - VESA STD
1152 x 864p at 75Hz - VESA ST
```

10 Protocol 2000

This RS-232/RS-485 communication protocol uses four bytes of information as defined below.

For RS-232, a null-modem connection between the machine and controller is used. The default data rate is 9600 baud, with no parity, 8 data bits and 1 stop bit.

Note: Compatibility with Kramer's Protocol 2000 does not mean that a machine uses all of the commands below. Each machine uses a sub-set of Protocol 2000, according to its needs.

10.1 Syntax

MSB								LSB
1st Byte		DESTINATION			INSTRUCTION			
0	D	N5	N4	N3	N2	N1	N0	
7	6	5	4	3	2	1	0	
2nd Byte		INPUT						
1	I6	I5	I4	I3	I2	I1	I0	
7	6	5	4	3	2	1	0	
3rd Byte		OUTPUT						
1	O6	O5	O4	O3	O2	O1	O0	
7	6	5	4	3	2	1	0	
4th Byte		MACHINE NUMBER						
1	OVR	X	M4	M3	M2	M1	M0	
7	6	5	4	3	2	1	0	

1st Byte: Bit 7 – Defined as 0
 D – DESTINATION:
 0 – Sends information to the switchers (from the PC)
 1 – Sends information to the PC (from the switcher)
 N5...N0 – INSTRUCTION

The 6-bit INSTRUCTION defines the function performed by the switcher(s). If a function is performed using the machine's keyboard, these bits are set with the INSTRUCTION NO. performed. The instruction codes are defined according to the table below (INSTRUCTION NO. is the value set in N5...N0).

2nd Byte: Bit 7 – Defined as 1
 I6...I0 – INPUT

When switching (i.e. instruction codes 1 and 2), the 7-bit INPUT is set as the input number to be switched. If switching is done using the machine's front panel, these bits are set with the INPUT NUMBER switched. For other operations, these bits are defined according to the table.

3rd Byte: Bit 7 – Defined as 1
 O6...O0 – OUTPUT

When switching (i.e. instruction codes 1 and 2), the 7-bit OUTPUT is set as the output number to be switched. If switching is done using the machine's front panel, these bits are set with the OUTPUT NUMBER switched. For other operations, these bits are defined according to the table.

4th Byte: Bit 7 – Defined as 1
 Bit 5 – Don't care
 OVR – Machine number override
 M4...M0 – MACHINE NUMBER

This byte is used to address machines in a system by their machine numbers. When several machines are controlled from a single serial port, they are usually configured together and each machine has an individual machine number. If the OVR bit is set, then all machine numbers accept (implement) the command and the addressed machine replies. When a single machine is controlled over the serial port, always set M4...M0 to 1, and make sure that the machine itself is configured as MACHINE NUMBER = 1.

Instruction Codes for Protocol 2000				
Instruction		Definition for Specific Instruction		Notes
#	Description	Input	Output	
1	SWITCH VIDEO	Set equal to video input that is switched (0 = disconnect)	Set equal to video output that is switched (0 = to all the outputs)	2, 15
61	IDENTIFY MACHINE	1 – Video machine name 2 – Audio machine name 3 – Video software version 4 – Audio software version 5 – RS-422 controller name 6 – RS-422 controller version 7 – Remote control name 8 – Remote software version 9 – Protocol 2000 revision 10 – Control data machine name 11 – Control data software version	For names: 0 – Request first 4 digits 1 – Request first suffix 2 – Request second suffix 3 – Request third suffix 10 – Request first prefix 11 – Request second prefix 12 – Request third prefix For versions: 0 – main board or the number of external board	13
62	DEFINE MACHINE	1 – Number of inputs 2 – Number of outputs 3 – Number of setups	1 – For video 2 – For audio 3 – For SDI 4 – For remote panel 5 – For RS-422 controller 6 – For control data	14

NOTES on the above table:

NOTE 2 – These are bi-directional definitions. If the switcher receives the code, it performs the instruction. If the instruction is performed (due to a keystroke operation on the front panel), then these codes are sent.

For example, if the PC sends HEX code:

01 85 88 83

then the switcher (machine 3) switches input 5 to output 8.

If the user switches input 1 to output 7 using the front panel buttons, the switcher sends HEX code:

41 81 87 83

to the PC.

When the PC sends one of the commands in this group to the switcher, if the instruction is valid, the switcher replies by sending the same four bytes to the PC that it received (except for the first byte, where the DESTINATION bit is set high).

NOTE 13 – This is a request to identify the switcher/s in the system. If the OUTPUT is set as 0, and the INPUT is set as 1, 2, 5 or 7, the machine sends its name. The reply is the decimal value of the INPUT and OUTPUT.

For example, for a 2216, the reply to the request to send the audio machine name is HEX code:

7D 96 90 81 (i.e. $128_{dec} + 22_{dec}$ for 2nd byte, and $128_{dec} + 16_{dec}$ for 3rd byte).

If the request for identification is sent with the INPUT set as 3 or 4, the appropriate machine sends its software version number. Again, the reply would be the decimal value of the INPUT and OUTPUT - the INPUT representing the number in front of the decimal point, and the OUTPUT representing the number after it.

For example, for version 3.5, the reply to the request to send the version number would be HEX code:

7D 83 85 81 (i.e. $128_{dec} + 3_{dec}$ for 2nd byte, $128_{dec} + 5_{dec}$ for 3rd byte).

If the OUTPUT is set as 1, then the ASCII coding of the lettering following the machine's name is sent.

For example, for the VS-7588YC, the reply to the request to send the first suffix would be HEX code:

7D D9 C3 81 (i.e. $128_{dec} + \text{ASCII for "Y"}; 128_{dec} + \text{ASCII for "C"}).$

NOTE 14 – The number of inputs and outputs refers to the specific machine being addressed, *not* to the system.

For example, if six 16x16 matrices are configured to make a 48x32 system (48 inputs, 32 outputs), the reply to the HEX code:

3E 82 81 82 (i.e. request the number of outputs)

would be HEX code:

7E 82 90 82 (i.e. 16 outputs).

NOTE 15 – When the OVR bit (4th byte) is set, then the video commands have universal meaning.

For example, instruction 1 (SWITCH VIDEO) causes all units (including audio, data, etc.) to switch. Similarly, if a machine is in FOLLOW mode, it performs any video instruction.

LIMITED WARRANTY

The warranty obligations of Kramer Electronics for this product are limited to the terms set forth below:

What is Covered

This limited warranty covers defects in materials and workmanship in this product.

What is Not Covered

This limited warranty does not cover any damage, deterioration or malfunction resulting from any alteration, modification, improper or unreasonable use or maintenance, misuse, abuse, accident, neglect, exposure to excess moisture, fire, improper packing and shipping (such claims must be presented to the carrier), lightning, power surges, or other acts of nature. This limited warranty does not cover any damage, deterioration or malfunction resulting from the installation or removal of this product from any installation, any unauthorized tampering with this product, any repairs attempted by anyone unauthorized by Kramer Electronics to make such repairs, or any other cause which does not relate directly to a defect in materials and/or workmanship of this product. This limited warranty does not cover cartons, equipment enclosures, cables or accessories used in conjunction with this product.

Without limiting any other exclusion herein, Kramer Electronics does not warrant that the product covered hereby, including, without limitation, the technology and/or integrated circuit(s) included in the product, will not become obsolete or that such items are or will remain compatible with any other product or technology with which the product may be used.

How Long Does this Coverage Last

Seven years as of this printing; please check our Web site for the most current and accurate warranty information.

Who is Covered

Only the original purchaser of this product is covered under this limited warranty. This limited warranty is not transferable to subsequent purchasers or owners of this product.

What Kramer Electronics will do

Kramer Electronics will, at its sole option, provide one of the following three remedies to whatever extent it shall deem necessary to satisfy a proper claim under this limited warranty:

1. Elect to repair or facilitate the repair of any defective parts within a reasonable period of time, free of any charge for the necessary parts and labor to complete the repair and restore this product to its proper operating condition. Kramer Electronics will also pay the shipping costs necessary to return this product once the repair is complete.
2. Replace this product with a direct replacement or with a similar product deemed by Kramer Electronics to perform substantially the same function as the original product.
3. Issue a refund of the original purchase price less depreciation to be determined based on the age of the product at the time remedy is sought under this limited warranty.

What Kramer Electronics will not do Under This Limited Warranty

If this product is returned to Kramer Electronics or the authorized dealer from which it was purchased or any other party authorized to repair Kramer Electronics products, this product must be insured during shipment, with the insurance and shipping charges prepaid by you. If this product is returned uninsured, you assume all risks of loss or damage during shipment. Kramer Electronics will not be responsible for any costs related to the removal or re-installation of this product from or into any installation. Kramer Electronics will not be responsible for any costs related to any setting up this product, any adjustment of user controls or any programming required for a specific installation of this product.

How to Obtain a Remedy under this Limited Warranty

To obtain a remedy under this limited warranty, you must contact either the authorized Kramer Electronics reseller from whom you purchased this product or the Kramer Electronics office nearest you. For a list of authorized Kramer Electronics resellers and/or Kramer Electronics authorized service providers, please visit our web site at www.kramerelectronics.com or contact the Kramer Electronics office nearest you.

In order to pursue any remedy under this limited warranty, you must possess an original, dated receipt as proof of purchase from an authorized Kramer Electronics reseller. If this product is returned under this limited warranty, a return authorization number, obtained from Kramer Electronics, will be required. You may also be directed to an authorized reseller or a person authorized by Kramer Electronics to repair the product.

If it is decided that this product should be returned directly to Kramer Electronics, this product should be properly packed, preferably in the original carton, for shipping. Cartons not bearing a return authorization number will be refused.

Limitation on Liability

THE MAXIMUM LIABILITY OF KRAMER ELECTRONICS UNDER THIS LIMITED WARRANTY SHALL NOT EXCEED THE ACTUAL PURCHASE PRICE PAID FOR THE PRODUCT. TO THE MAXIMUM EXTENT PERMITTED BY LAW, KRAMER ELECTRONICS IS NOT RESPONSIBLE FOR DIRECT, SPECIAL, INCIDENTAL OR CONSEQUENTIAL DAMAGES RESULTING FROM ANY BREACH OF WARRANTY OR CONDITION, OR UNDER ANY OTHER LEGAL THEORY. Some countries, districts or states do not allow the exclusion or limitation of relief, special, incidental, consequential or indirect damages, or the limitation of liability to specified amounts, so the above limitations or exclusions may not apply to you.

Exclusive Remedy

TO THE MAXIMUM EXTENT PERMITTED BY LAW, THIS LIMITED WARRANTY AND THE REMEDIES SET FORTH ABOVE ARE EXCLUSIVE AND IN LIEU OF ALL OTHER WARRANTIES, REMEDIES AND CONDITIONS, WHETHER ORAL OR WRITTEN, EXPRESS OR IMPLIED. TO THE MAXIMUM EXTENT PERMITTED BY LAW, KRAMER ELECTRONICS SPECIFICALLY DISCLAIMS ANY AND ALL IMPLIED WARRANTIES, INCLUDING, WITHOUT LIMITATION, WARRANTIES OF MERCHANTABILITY AND FITNESS FOR A PARTICULAR PURPOSE. IF KRAMER ELECTRONICS CANNOT LAWFULLY DISCLAIM OR EXCLUDE IMPLIED WARRANTIES UNDER APPLICABLE LAW, THEN ALL IMPLIED WARRANTIES COVERING THIS PRODUCT, INCLUDING WARRANTIES OF MERCHANTABILITY AND FITNESS FOR A PARTICULAR PURPOSE, SHALL APPLY TO THIS PRODUCT AS PROVIDED UNDER APPLICABLE LAW.

IF ANY PRODUCT TO WHICH THIS LIMITED WARRANTY APPLIES IS A "CONSUMER PRODUCT" UNDER THE MAGNUSON-MOSS WARRANTY ACT (15 U.S.C.A. §2301, ET SEQ.) OR OTHER APPLICABLE LAW, THE FOREGOING DISCLAIMER OF IMPLIED WARRANTIES SHALL NOT APPLY TO YOU, AND ALL IMPLIED WARRANTIES ON THIS PRODUCT, INCLUDING WARRANTIES OF MERCHANTABILITY AND FITNESS FOR THE PARTICULAR PURPOSE, SHALL APPLY AS PROVIDED UNDER APPLICABLE LAW.

Other Conditions

This limited warranty gives you specific legal rights, and you may have other rights which vary from country to country or state to state.

This limited warranty is void if (i) the label bearing the serial number of this product has been removed or defaced, (ii) the product is not distributed by Kramer Electronics or (iii) this product is not purchased from an authorized Kramer Electronics reseller. If you are unsure whether a reseller is an authorized Kramer Electronics reseller, please visit our Web site at www.kramerelectronics.com or contact a Kramer Electronics office from the list at the end of this document.

Your rights under this limited warranty are not diminished if you do not complete and return the product registration form or complete and submit the online product registration form. Kramer Electronics thanks you for purchasing a Kramer Electronics product. We hope it will give you years of satisfaction.



For the latest information on our products and a list of Kramer distributors, visit our Web site where updates to this user manual may be found.

We welcome your questions, comments, and feedback.

Web site: www.kramerelectronics.com

E-mail: info@kramerel.com



SAFETY WARNING

Disconnect the unit from the power supply before opening and servicing

P/N: 2900-00644



Rev: 8

