

**Refrigeration Equipment
Bottle Cooler with Slide Top,
10 cu.ft, 36" (R600a)**

ITEM # _____

MODEL # _____

NAME # _____

SIS # _____

AIA # _____



738294 (KCHBC36)

1-door bottle cooler with slide top, 36", R600a refrigerant gas, +33/+41 °C, black

Short Form Specification

Item No. _____

Bottle cooler with slide top. Exterior back and side panels in painted steel, exterior bottom panel in galvanized steel, top panel in 304 stainless steel; interior back and side panels in 430 stainless steel, interior bottom panel and worktop in 304 stainless steel. Fin & tube condenser to improve the performances in high temperature environments. Automatic Defrost Cooling System and electronic temperature control.

Vinyl-coated steel adjustable dividers and locking lids.

R600a gas in refrigeration circuit.
ETL Safety and Sanitation certified.
3/5 Years warranty.

Main Features

- Fin & Tube Condenser improves performance in high temperature environments.
- Automatic Defrost Cooling System provides worry-free performance.
- Vinyl-Coated Steel adjustable dividers to customize bottle storage effortlessly.
- Locking doors.
- External temperature display.
- High efficiency components to minimize the energy consumption still guaranteeing the highest performances.
- Cabinet and door insulated with high density polyurethane for low environmental impact.
- Locking lids.

Construction

- CFC and HCFC free (ecological refrigerant type: R600a).
- Pre-wired heavy duty power cord.
- Electronic control to select temperatures.

APPROVAL: _____

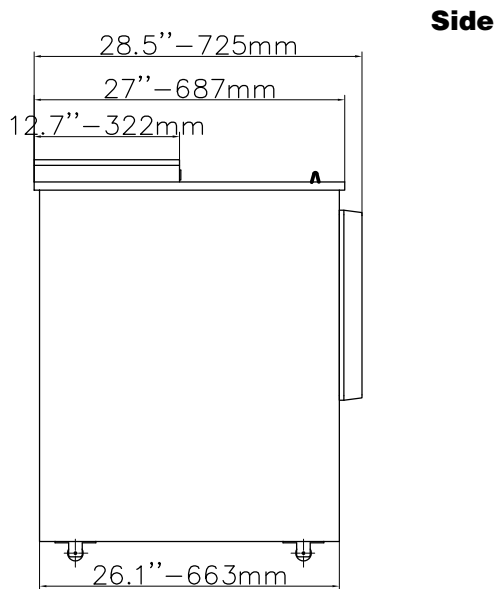
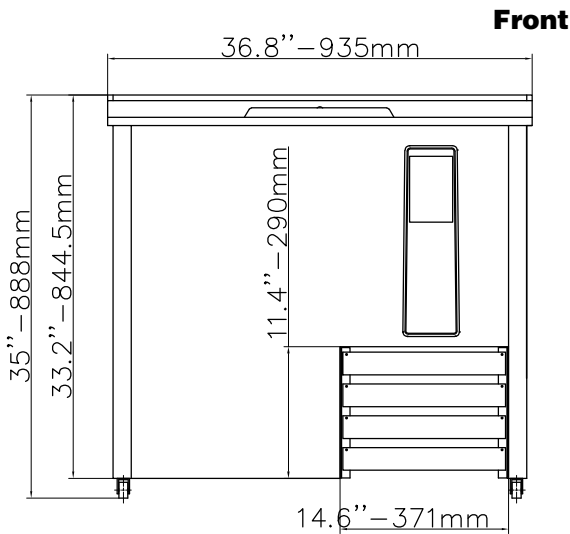

EI = Electrical connection

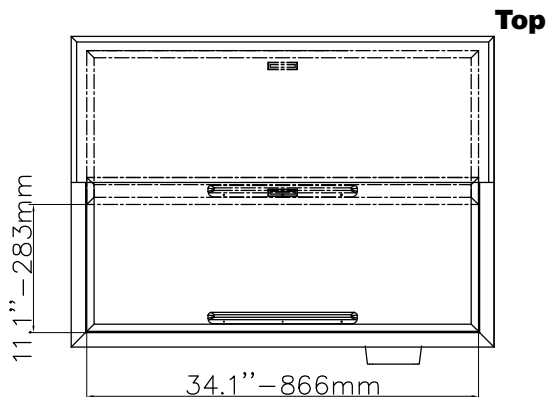

Electric

Supply voltage:	738294 (KCHBC36)	115 V/1 ph/60 Hz
Electrical power, max:		0.2 kW
Current consumption:		1.5 Amps
Plug type:		USA NEMA 5-15P

Capacity:

Gross capacity:	10 cu.feet
-----------------	------------

Key Information:

External dimensions, Width:	36 13/16" (935 mm)
External dimensions, Depth:	27 1/64" (725 mm)
External dimensions, Height:	35 " (888 mm)
Internal Dimensions (depth):	26 1/16"
Internal Dimensions (height):	22 15/16"
Internal Dimensions (width):	60 3/8"
Shipping height:	39 3/4" (1010 mm)
Shipping weight:	212 lbs (96 kg)
Shipping volume:	25.25 ft ³ (0.72 m ³)
Type of external material:	Black Prepainted Steel
Type of internal material:	Stainless Steel
Warranty:	3 / 5 years

Refrigeration Data

Compressor Horsepower:	1/6
Refrigerant type:	R600a
Refrigerant weight:	100 g
Operating temperature min.:	32 °F
Operating temperature max.:	41 °F
Condenser type:	Fin & tube

