

Installation & User Manual

Applies to Part Numbers:

TUN-590404, TUN-590804

AXYS® IndustryAmp (Dante™)

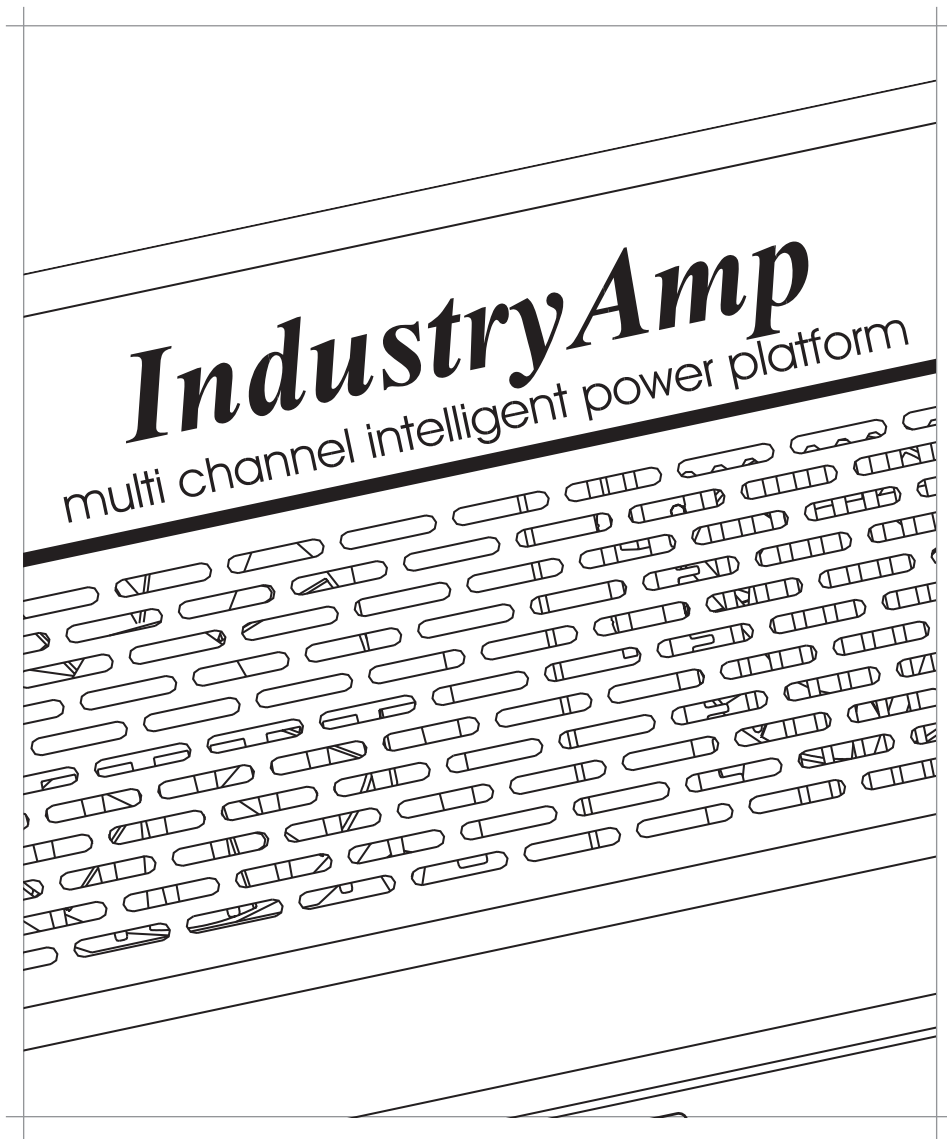

Delivering Clear and Intelligible Messages



REFERENCE TO EC STATEMENT OF CONFORMITY

This document confirms that products manufactured by Harman Professional Kft. bearing the CE label meet all the requirements in the EMC directive 2014/30/EU and LV directive 2014/35/EU laid down by the Member States Council for adjustment of legal requirements. Harman Professional Kft. products bearing the CE label comply with the following harmonised or national standards:

EMC:

EN 55032:2012/AC:2013

EN 55035:2017

EN 50130-4:2011

Safety:

EN 60065:2014 (edition 8)

Mains Harmonics:

EN 61000-3-2:2014

Insulation:

Class1

Harman Professional Kft.

Szilva u. 1-3.

H-7632 Pécs

Hungary

USER'S NOTICE AND DISCLAIMER

No part of this manual may be reproduced, transmitted, transcribed, stored in a database system or translated without the express written permission of Harman Professional. Documentation kept by the end user for back-up purposes is excluded from the above.

All products and corporate names mentioned in this manual may be registered trademarks or copyrights of their respective companies. They are used here for indicative purposes only.

The information contained in this manual has been carefully checked for accuracy; however no guarantee is given with respect to its correctness. Harman Professional accepts no responsibility or liability for any errors or inaccuracies that may appear in this manual or the products described in it.

Specifications and information contained in this manual are subject to change at any time without notice.

© 1998-2021 Harman Professional Kft. All rights reserved.

FCC STATEMENT

This equipment has been tested and found to comply with the limits for a Class B digital device, pursuant to part 15 of the FCC Rules. These limits are designed to provide reasonable protection against harmful interference in a residential installation. This equipment generates, uses and can radiate radio frequency energy and, if not installed and used in accordance with the instructions, may cause harmful interference to radio communications. However, there is no guarantee that interference will not occur in a particular installation. If this equipment does cause harmful interference to radio or television reception, which can be determined by turning the equipment off and on, the user is encouraged to try to correct the interference by one or more of the following measures:

- Reorient or relocate the receiving antenna.
- Increase the separation between the equipment and receiver.
- Connect the equipment into an outlet on a circuit different from that to which the receiver is connected.
- Consult the dealer or an experienced radio/TV technician for help.

TABLE OF CONTENTS

REFERENCE TO EC STATEMENT OF CONFORMITY	2
User's Notice and disclaimer	2
TABLE OF CONTENTS	3
IMPORTANT SAFETY INSTRUCTIONS	4
INTRODUCTION	5
Applicable models	5
Overview	5
Features	6
What's in the packaging	6
GENERAL DESCRIPTION	7
Block diagram and system description	7
Front Panel	9
Rear Panel	9
INSTALLATION AND OPERATION	10
Mechanical Installation	10
Ventilation	10
Connector and Wiring details	11
AC Mains	11
Audio Connections	12
Analogue inputs	12
Amplifier outputs	12
Dante™ and Control Interface	13
ANS microphone input	13
Failure relay	14
DSP section overview	15
Level controls	16
EQ adjustment	16
Matrix	16
Autogain	16
Delay	16
Surveillance functions	16
Auto-input switching	16
Failure relay	17
Presets	18
DSP bypass	18
Load Monitoring	18
Amplifier protection	18
Surge protection	18
Power-on delay	18
Dante™ configuration	18
APPENDIX	19
Technical Specifications	19
Maintenance and Warranty Information	19
Common Analogue Grounding Issues	19
Software and Firmware Updates	19

IMPORTANT SAFETY INSTRUCTIONS



This symbol is intended to alert you to the presence of uninsulated dangerous voltages within the product's enclosure that may be of sufficient magnitude to constitute a risk of electric shock.



This symbol is used throughout this manual and is intended to alert you to the presence of important instructions.

1. Read these instructions.
2. Keep these instructions.
3. Heed all warnings.
4. Follow all instructions.
5. Do not use this apparatus near water.
6. Clean only with dry cloth.
7. Do not block any ventilation openings. Install in accordance with the manufacturer's instructions.
8. Do not install near any heat sources such as radiators, heat registers, stoves, or other apparatus (including amplifiers) that produce heat.
9. Do not defeat the safety purpose of the polarised or grounding-type plug. A grounding type plug has two blades and a third grounding prong. The wide blade or the third prong is provided for your safety. If the provided plug does not fit into your outlet, consult an electrician for replacement of the obsolete outlet.
10. Protect the power cord from being walked on or pinched particularly at plugs, convenience receptacles, and the point where they exit from the apparatus.
11. Only use attachments/accessories specified by the manufacturer.
12. Unplug this apparatus during lightning storms or when unused for long periods of time.
13. Refer servicing to qualified service personnel. Servicing is required when the apparatus has been damaged in any way, such as power-supply cord or plug is damaged, liquid has been spilled or objects have fallen into the apparatus, the apparatus has been exposed to rain or moisture, does not operate normally, or has been dropped.



Warning - To reduce the risk of fire or electric shock, do not expose this apparatus to rain or moisture and objects filled with liquids, such as vases, should not be placed on this apparatus.



Warning - To disconnect this apparatus from the mains power supply, turn off the power at the power switch on the rear panel and remove the PowerCon® connector from the mains input socket labelled Mains on the rear panel.



Warning - The PowerCon® connector should never be plugged or unplugged when there is power on the connector, regardless of whether the amplifier is switched on or not. ALWAYS ensure that the mains supply is turned off at source before inserting or removing the PowerCon®.



Warning - This apparatus is a Class I device and must be connected to a mains socket outlet that provides a safety ground connection.

INTRODUCTION

Thank you for purchasing this AXYS® IndustryAmp.

In order to get the best out of your IndustryAmp, please take the time to read through this manual before you install and use it for the first time.

APPLICABLE MODELS

This manual covers the installation and operation of the following models:

- IndustryAmp Model PB-400-DN (Part No. TUN-590404): 2 analogue inputs plus dual-redundant Dante™ interface, 4 x 250 W output into 40 ohm load
- IndustryAmp Model PB-800-DN (Part No. TUN-590804): 2 analogue inputs plus dual-redundant Dante™ interface, 8 x 100 W output into 100 ohm load

OVERVIEW

The AXYS® IndustryAmp is a multichannel power amplifier specifically designed for permanent installation in life-safety and other critical applications. It is designed to drive loudspeakers in distributed 70 V or 100 V line systems. The core of the amplifier is a DSP (Digital Signal Processing) block, which allows comprehensive adjustment of the audio signals in each channel. The unit also incorporates a number of fail-safe features, making it very reliable and suitable for use in life-critical situations.

The IndustryAmp is configured, controlled and monitored using AXYS® WinControl software, via the Dante™ Ethernet interfaces.

FEATURES

- Transformer-coupled outputs for direct drive of 70 V / 100 V line systems
- Full complementary Class AB output stages
- MOSFET output devices with high current safety margin
- Stable operation under all normal conditions
- Two transformer-balanced analogue inputs (0 dBV)
- On-board DSP, providing control of level, EQ, delay, etc. on all inputs and outputs
- Full configuration, control and monitoring using AXYS® WinControl software
- Non-volatile storage of all amplifier parameters
- Control and monitoring via the AxysBridge protocol by using the Dante™ Ethernet interfaces
- Pilot tone detection
- ANS (Ambient Noise Sensing) mic input
- Surveillance/failure relay
- DSP bypass function
- Universal power supply (100-240 VAC) with active Power Factor correction
- Integral dual-redundant Dante™ audio networking card
- Sixteen digital audio inputs
- Seventeen digital audio outputs
- Input to amplifier output audio matrix router

WHAT'S IN THE PACKAGING

In addition to the IndustryAmp itself, each unit is shipped with the following items:

- Installation and User Manual (this document)
- AC power cable (2 m), fitted with a Neutrik® PowerCon® connector and a Schuko (European-style) mains plug
- AC power cable (2 m), fitted with a Neutrik® PowerCon® connector and a Type B (USA style) mains plug
- Set of mating screw terminal connectors

GENERAL DESCRIPTION

BLOCK DIAGRAM AND SYSTEM DESCRIPTION

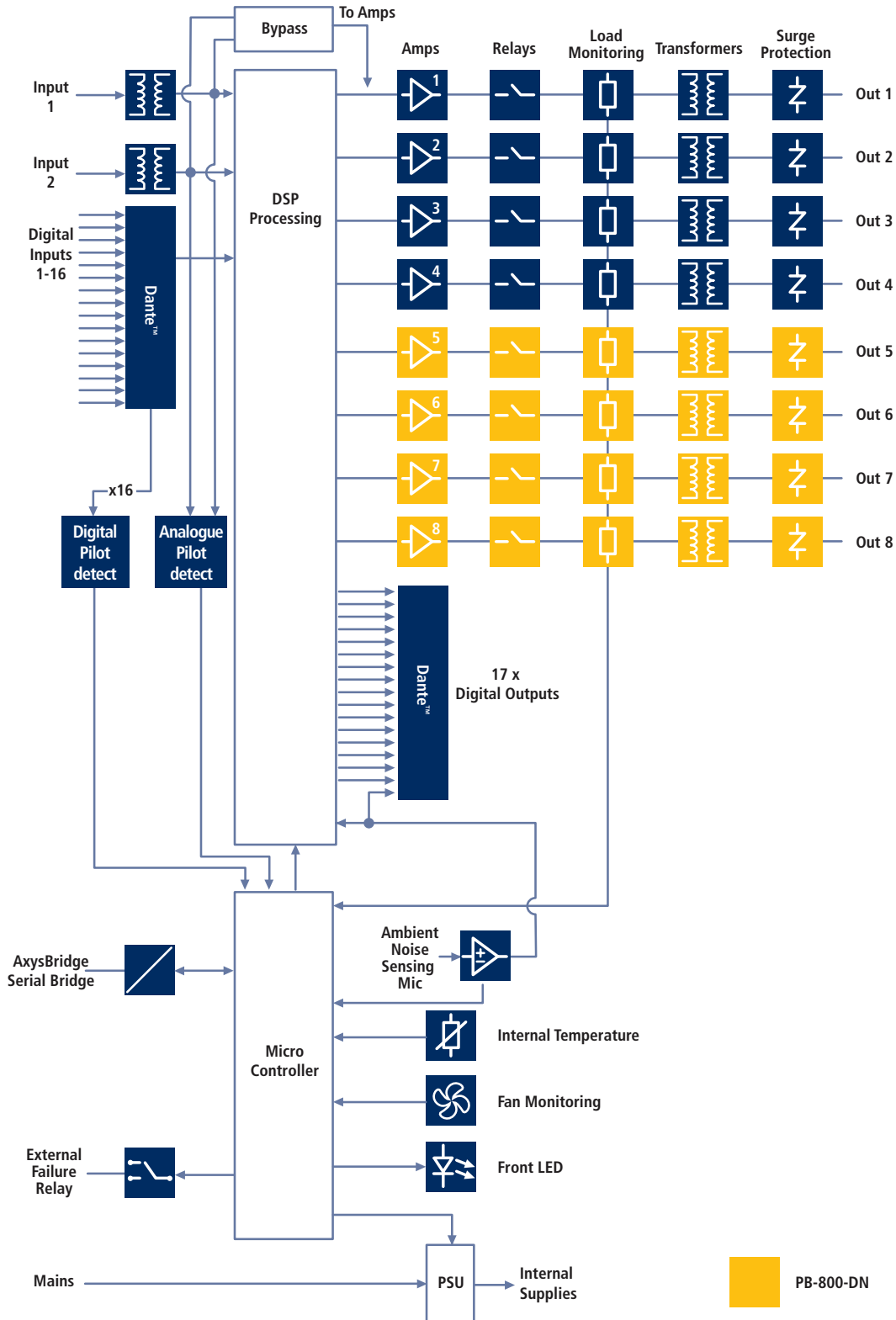

The simplified block diagram above shows the unit's internal signal routing.

The unit has two analogue inputs, making it suitable for connection to primary and secondary audio sources in life-safety applications. The inputs are transformer-balanced and offer low noise and very high CMRR (Common-Mode Rejection Ratio).

The audio transformers fitted to the analogue inputs are of professional grade and provide full galvanic isolation from source and destination equipment, eliminating the potential for ground loops to occur between items of equipment which may be running on different AC supplies.

The analogue input and A-D converter stages accept a peak signal level of +19 dBV without clipping. (At high input levels, the digital gain within the DSP block will normally need to be reduced to avoid continuous activation of the limiter section.)

Both inputs can be routed to all amplifier channels - four in the PB-400-DN and eight in the PB-800-DN - via the DSP core.

The amplifier power section employs a fully complementary Class AB design, using MOSFET devices with a much higher current rating than is necessary for normal operation. The power stages feature power-on delay, load monitoring and surge protection.

Both analogue inputs feed a pilot tone detector so that continuous monitoring of the input connections may be made. The detector will, when enabled, switch from

Input 1 to Input 2 if pilot tone is lost. The IndustryAmp incorporates surveillance functions which activate an externally-accessible failure relay in the event of a PSU or other malfunction, or a loss of pilot tone.

A further sixteen digital inputs are also available. These are routed to the DSP core along with the analogue inputs, and are also continuously monitored for pilot-tone, with the same auto-switching arrangement as the analogue inputs. All active inputs (as enabled via WinControl) are routed to all output channels. The Dante™ interface is bi-directional, the analogue inputs and some processed inputs can be transmitted to the Dante™ network. The input from an optional Ambient Noise Sensing microphone is transmitted on channel 17 of the Dante™ interface. This permits an ANS mic to be monitored at a remote location.

The Dante™ card also allows the IndustryAmp to be controlled by WinControl via the AxysBridge protocol by using the Dante™ Ethernet interfaces. These interfaces can either connect to primary and secondary 1 Gb/s Dante™ networks, or provide daisy-chaining in non-redundant operation mode.

The high-power main supply is conservatively rated and operates on any AC supply voltage from 100 V to 240 V, and incorporates active Power Factor correction to minimise mains harmonics in the audio. Apart from the main supply, the IndustryAmp is also equipped with a low-power standby supply. This power supply allows the device to be powered on and off under network control.

FRONT PANEL

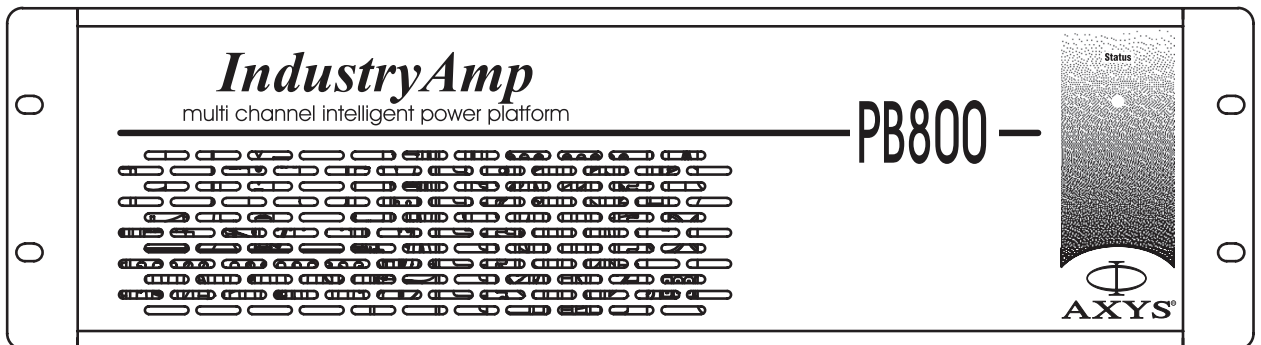

1. Status LED – bi-colour LED: normal (green), failure (red).

REAR PANEL

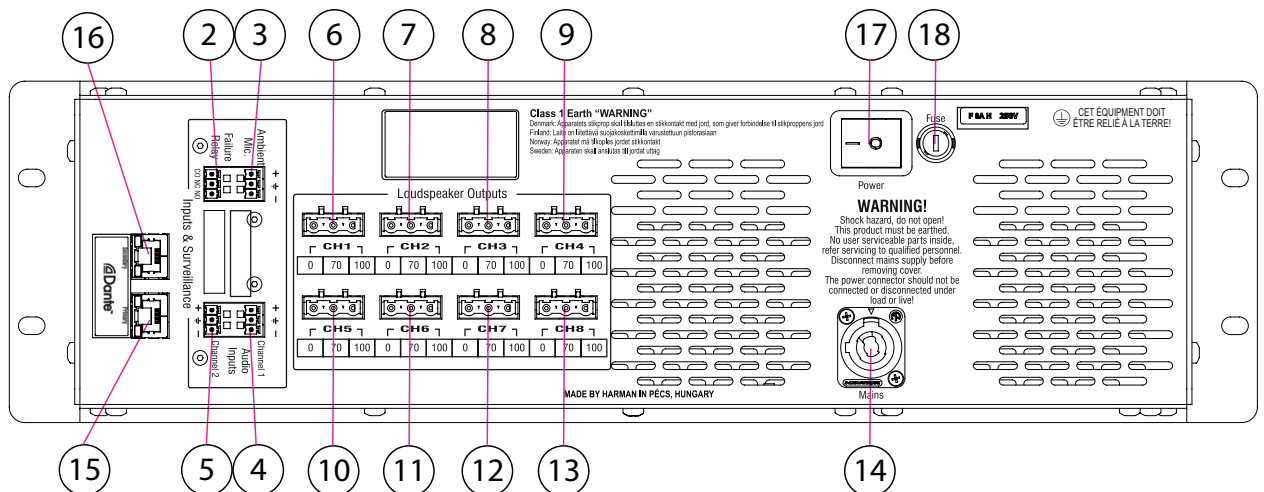

- | | | | |
|----------------------------|-------------|---------------|---------------------------|
| 2. Failure relay connector | 6. Output 1 | 10. Output 5* | 14. Mains power connector |
| 3. ANS microphone input | 7. Output 2 | 11. Output 6* | 15. Dante™ Primary Port |
| 4. Analogue input 1 | 8. Output 3 | 12. Output 7* | 16. Dante™ Secondary Port |
| 5. Analogue input 2 | 9. Output 4 | 13. Output 8* | 17. Mains switch |
| | | | 18. Mains fuse |

Wiring details for all the rear connectors can be found in subsequent sections of the manual.

* Not present on PB-400-DN

INSTALLATION AND OPERATION

MECHANICAL INSTALLATION

The IndustryAmp is designed to be mounted in a standard 19" equipment rack. The front panel is fitted with rackmount ears for this purpose. The IndustryAmp occupies 3U of vertical rack space.



Note that due to the weight of the amplifier (over 20 kg), the use of additional rear supports is strongly recommended. The rear of the unit has additional mounting points to facilitate this.

Ventilation

The IndustryAmp is forced-air cooled by two internal temperature-controlled fans. This ventilation method should ensure that amplifier remains within its operational temperature range under most circumstances, but if it is to be installed in a location of high ambient temperature, and/or in a rack containing a significant quantity of other heat-generating equipment (see below), consideration should be given to climate-controlling the room in which the equipment rack is situated.



Do not install the IndustryAmp in a 19" rack immediately above or below another item of equipment generating a significant amount of heat (e.g., another power amplifier). Plain 1U blank panels should be used as spacers. Note that slotted or perforated ventilation panels should not be used, as these will reduce the effect of forced-air cooling. Also, be aware of the rear-to-front direction of airflow of the IndustryAmp; it is not good practice to install equipment employing forced-air cooling with different directions of airflow in the same enclosed rack.



Airflow is via the grilles at the rear (intake) and front (exhaust) of the amplifier. Ensure that both sets of grilles are completely clear of any obstructions within 100 mm (4") in order to maintain the necessary airflow.

CONNECTOR AND WIRING DETAILS

AC Mains

 AC power is via a rear panel Neutrik® PowerCon® Type 20 mains connector [14]. A mating mains cable (power cord) fitted with a European-style plug is supplied with the unit. If the standard AC outlets in the territory are of a different type, the correct type of mains plug should be substituted, carefully observing the following cable colour codes:

CONNECT	COLOUR (EUROPE)	COLOUR (US)
Live	Brown	Black
Neutral	Blue	White
Earth (Ground)	Green/Yellow	Green

The IndustryAmp incorporates a “universal” PSU, and will operate on all AC mains voltages from 100 V to 240 V.

 **NOTE:** The IndustryAmp has an AC mains fuse. The fuseholder is on the rear panel [18]. In the event of the fuse blowing, always first investigate why it blew. Always replace by a fuse of the same type and rating as indicated on the rear panel and/or in the amplifier datasheet.

 **NOTE:** The PowerCon® connector should NEVER be plugged in or unplugged while AC mains is present. This applies whether or not the amplifier is switched on. ALWAYS isolate the AC mains supply at its source before plugging or unplugging the connector.

 **Warning** - This apparatus is a Class I device and must be connected to a mains socket outlet that provides a safety ground connection.

 **Warning** - Presence of mains voltage is not indicated by the LED on the front panel. This LED indicates the status of the IndustryAmp and cannot be used as a mains voltage indicator.

 If the mains switch of the IndustryAmp is not readily accessible after installation to disconnect the unit when necessary, the mains connection to the IndustryAmp should incorporate a manual circuitbreaker or an accessible mains plug.

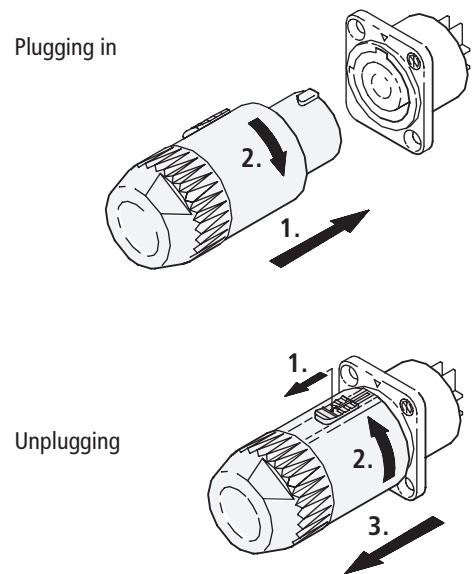

fig.1: PowerCon Connector

AUDIO CONNECTIONS

Analogue inputs

The analogue audio inputs use 3-pin 3.81 mm-pitch screw terminal connectors. Mating connectors are supplied with the unit. The inputs should be wired according to the diagram below:

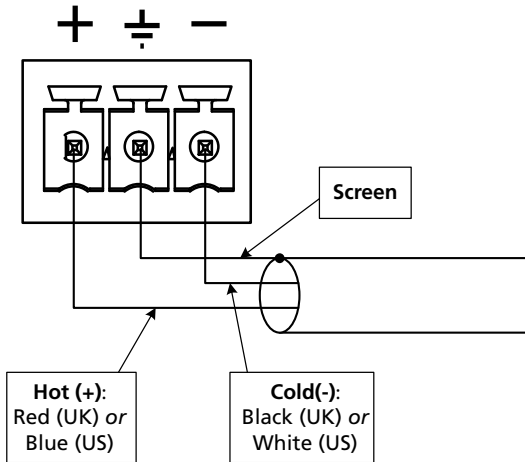

fig.2: Analogue Inputs

To minimise hum and noise pickup, balanced analogue interconnections between audio sources and the IndustryAmp should always be used wherever possible. If driving from an unbalanced source, use the same wiring as shown above at the amplifier end, but connect the 'hot' core to the signal output and the 'cold' core to the ground terminal of that output; the cable's own screen should be connected at the amplifier end only.

Amplifier outputs

The amplifier outputs are on 3-pin 7.62 mm-pitch screw terminal connectors. The secondary winding of each channel's 100 V-line output transformer has an intermediate tapping for use with 70 V-line systems, and this is available at the same connector. Wire the output connectors as shown below:

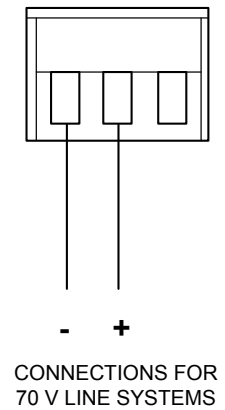
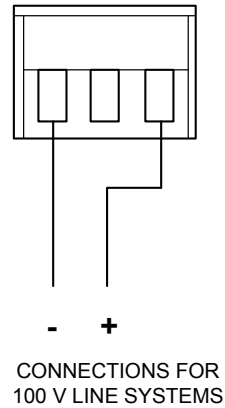

fig.3: Amplifier Outputs

Dante™ and Control Interface

Connections to the Dante™ card are made via RJ-45 connectors. Either the Port labeled 'Primary' or labeled 'Secondary' may be used; if a dual redundant network is employed in the installation, then use both ports, connecting each to independent Ethernet switches. Separate networks are required for Dante™, not only separate switches (see Dante™ recommendations). Primary and secondary interface cannot be connected to the same network.



NOTE: A connection to 1 Gb/s network is strongly recommended.

Standard pre-made CAT-5e or higher (CAT-6 etc) network cables (see note hereafter) may be used to connect amplifiers to the local Ethernet switch(es). However, in many installations, the network connection from within a rack to an Ethernet switch will be via structural cabling. In this case, wire mating RJ-45 plugs (not supplied) as shown below:



fig.4: Dante™ Connectors

This is the T-568B standard (preferred), T-568A standard is also used and uses different colour mapping

PIN	CAT-5e CORE
1	White + Orange
2	Orange
3	White + Green
4	Blue
5	White + Blue
6	Green
7	White + Brown
8	Brown

The maximum cable run for reliable operation using CAT-5e cable is of the order of 100 m. If longer distances are involved, the use of multimode fibre-optic cable is recommended. This is generally satisfactory up to 2 km, but repeaters (or the use of single-mode fibre) can be used to increase the distance further. A third-party Ethernet-to-fibre interface will be required in these situations.

The Dante™ interfaces add digital audio I/O and a control method to the IndustryAmp. They provide sixteen additional audio inputs and seventeen audio outputs, at a sampling rate of 48 kHz and bit depths of 16, 24 or 32 bits.



NOTE: Unscreened CAT-5e UTP cable can be used, but note that the amplifier may fail to preserve its high level of surge immunity and as a consequence, will no longer be compliant with the standards set out in the EC Statement of Conformity. CAT-5e twisted pair cable with an overall foil shield (referred to as FTP or F/UTP) is required for compliance.

ANS microphone input

The IndustryAmp's DSP card includes an Autogain algorithm which adjusts the gain of the amplifier in response to ambient noise levels. To accomplish this, an external Ambient Noise Sensing (ANS) microphone must be connected to the ANS mic input.

Connection is via a 3-pin 3.81 mm-pitch screw terminal connector, with the same pinout as the analogue audio inputs. See "fig.2: Analogue Inputs" on page 12 for wiring details.

Note the post-preamp ANS mic signal is transmitted on channel 17 of the Dante™ interface. This permits an ANS mic to be monitored at a remote location.

A suitable AXYS® ANS microphone is available as an option (Part No. TUN-ANS). This should be wired using a single twisted-pair cable with an overall screen. Connect the microphone pair to the '+' and '-' pins of the Ambient Microphone input. The cable's overall screen should be connected to the pin of the Ambient Microphone input marked with an earth \perp (ground) symbol .

Failure relay

The IndustryAmp includes a single-pole changeover relay whose contacts are accessible on a 3-pole 3.81 mm-pitch screw terminal connector. The conditions under which the relay operates are defined as part of the amplifier configuration in WinControl.

The relay connections may be configured either as volt-free, or with additional internal resistors to allow them to be connected directly to impedance-sensing line monitoring equipment such as the AXYS® Cerberus. This selection is made by moving an internal PCB jumper. See “fig.5: Failure relay”.

In volt-free operation, CO is connected to NC; a failure condition causes CO to be connected to NO.

When configured for impedance-sensing use, the impedance between CO and NC is 10k Ω and open-circuit between CO and NO in normal operation. When a fault condition occurs, the impedance between CO and NC rises to 20k Ω, and CO is short-circuited to NO.

An AXYS® Cerberus or other impedance-sensing fault monitoring equipment may be connected to CO and NC. The contact wiring arrangement is shown in “fig.5: Failure relay”.

The relay contacts have maximum current and voltage ratings of 100 mA and 24 V respectively.

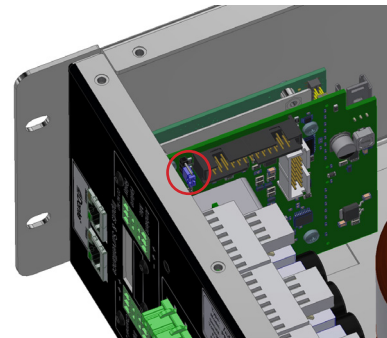
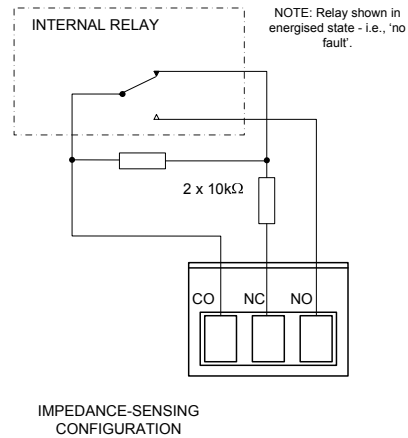
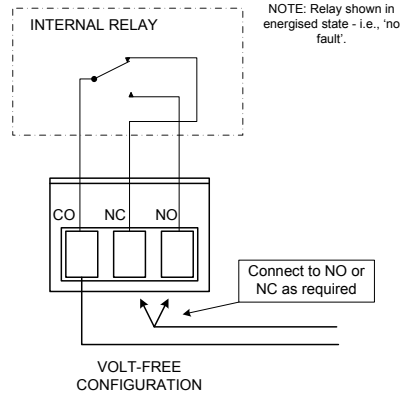

fig.5: Failure relay

Configuration	Jumper	Notes
Volt-free	Towards bottom	Factory default
Impedance-sensing	Towards top	-

DSP SECTION OVERVIEW

The IndustryAmp incorporates a 32-bit floating point Digital Signal Processor (DSP) in conjunction with 24-bit 128x-oversampling A-D and D-A conversion. This permits a very extensive range of system parameters to be controlled remotely and for internal storage of unit configuration.

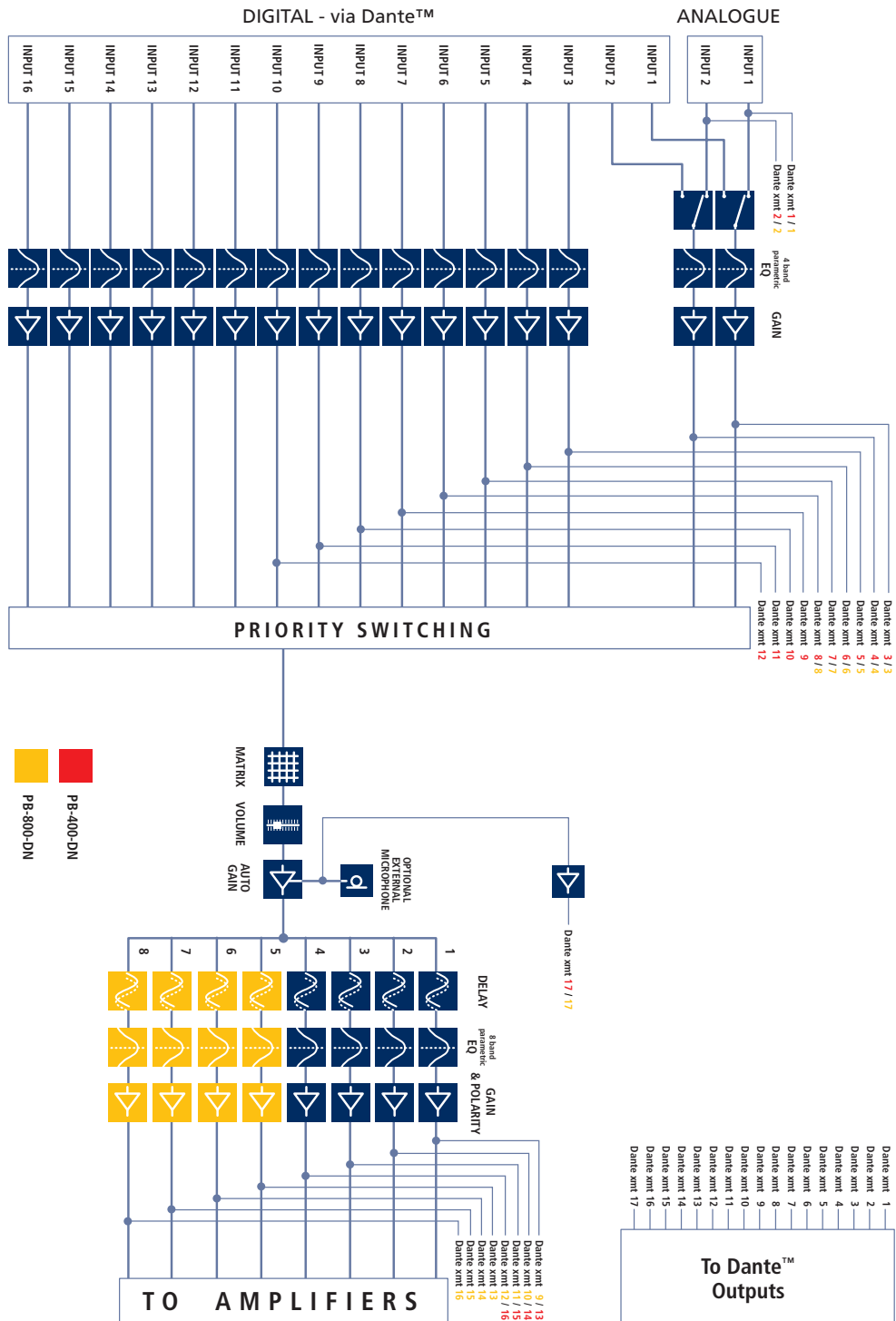

fig.6: DSP block diagram

All DSP functions are adjusted using the WinControl software application. Detailed information on the use of WinControl is beyond the scope of this manual, and users should consult the WinControl Help files.

Level controls

The gain of each analogue input and each digital input may be adjusted independently over the range -70 dB to +20 dB. Nominal input level with 0 dB gain is 0 dBV, and the maximum input level is +19 dBV (peak).

The source of DSP audio input 1 and 2 (either analogue or Dante™) is software configurable.

The output level of each amplifier channel can also be set independently, with a range of 80 dB.

Note that after the inputs have been summed, there is also a master level control ("Volume"), which provides a single-point adjustment of the output levels of all amplifier channels.

Polarity (phase) inversion is also available for each input and output.

EQ adjustment

The DSP section provides very comprehensive signal equalisation for both inputs and outputs. Each analogue input and each digital input has its own 4-band parametric equaliser. Each amplifier channel has its own 8-band parametric equaliser. These provide up to 25 dB of cut or boost per band (depending on filter type selected) over the range 10 Hz to 24 kHz, with per-band selection of filter type.

Output equalisation can be used to construct crossover filtering to allow the IndustryAmps to be used with multi-way loudspeaker systems. Input equalisation permits tailoring of individual input signals for optimum clarity.

Matrix

A matrix is provided so that any of the sixteen inputs can be routed to any of the amplifier outputs. Where more than one input is selected to go to the same output then the inputs are summed.

Autogain

The DSP section includes an autogain algorithm which can be set to automatically adjust the overall volume level according to the ambient noise level detected by a microphone connected at the ANS mic input. The algorithm measures the ambient noise in gaps in the programme material being fed via the IndustryAmp. Once enabled, the amount of additional gain per dB of ambient noise increase can be controlled, as well as the threshold at which gain adaption begins.

The autogain algorithm can also be used to provide a level attenuation depending on a "volt free" input on the ANS mic input (pins '+' and '-'). When the input is open circuit then the autogain provides no reduction in overall volume, when the input is short circuit the predefined reduction in volume set by the autogain comes into affect.

Delay

Delay may be inserted in the output channel of the audio signal chain.

SURVEILLANCE FUNCTIONS

The IndustryAmp incorporates various surveillance features to ensure continuous operation in critical applications.

Auto-input switching

Normal configuration of the IndustryAmp is for up to sixteen inputs to be permanently summed, so that signals on all enabled inputs are always fed through the system (matrix selection dependent)

However, if wished, priorities may be assigned to individual inputs so that audio through the system is normally derived from one input only. The inputs are then monitored, either for presence of pilot tone, or for a continuous signal level above a pre-determined threshold. In the event of non-detection of the pilot tone or input signal, the signal source can be switched to that on an alternative input.

This arrangement is primarily intended to provide redundancy; by utilising more than one audio distribution path, a high degree of system of security can be gained.

The Input Mode setting in WinControl (at **Input > Common parameters**) allow selection of auto-switching mode. A brief description of each mode follows; see the WinControl Help files for full details.

Normal

Auto-switching is disabled. All inputs are active, if more than one inputs is selected to go to an output (selected using the matrix) then the inputs are summed.

Level-controlled priority switching

When enabled, the inputs will switch when the signal level at the detection point drops below -60 dBFS (default value), but this threshold may be set to any level between -80 dBFS and -20 dBFS. The detection point is either 'At input' or 'After processing'. In the latter case filtering may be applied, for example to reduce the level of an input pilot tone. When using analogue inputs, the relationship between dBFS and dBV's measured at the amplifier's inputs should be taken into consideration; WinControl's Help files give full details.

It is also possible to set a Hold Time, so that unwanted switching does not occur between natural gaps in the programme.

Pilot tone-controlled priority switching

It is common practice in critical audio systems to permanently route a low level, high-frequency tone through the system. The presence of this pilot tone can then be detected by various items of equipment to verify the continued operation of the audio paths. Set Input Mode to Pilot tone-controlled priority switching to enable this mode.

The IndustryAmp's pilot tone detector on the analogue inputs operates in the frequency range of approximately 20 kHz to 28 kHz. The detector is most sensitive in the center of this frequency range, the detection threshold is not software configurable. On the digital (Dante™) inputs the frequency range is 19.2 kHz to 23.5 kHz and the threshold may be set between -10 dBFS and -60 dBFS.

The amplifier's action on non-detection of a pilot tone can be configured via WinControl. A fault condition can be "flagged", and/or the input can be set auto-switch to that with the next priority.



A notch filter should be inserted to suppress the pilot tone if its frequency is less than half the internal processor's sample frequency ($F_s/2$, typically 24 kHz). If the pilot tone is not sufficiently suppressed, signal detection (and other functions such as frost protection and Autogain) will not function properly. Further, this may result in excessive dissipation in the power amplifiers and/or connected loudspeakers, or interference with the internally-generated tone used for load monitoring. Pilot tone frequencies above $F_s/2$ are sufficiently suppressed by the anti-aliasing filter of the ADC. Any pilot tone frequency received via the digital inputs is $< F_s/2$ by default.

Take notice of the following when configuring the parameters for the input pilot tone detection:



It is advised to use a few seconds of Grace time in order to avoid spurious input pilot tone monitoring errors.



Use a fixed frequency if the frequency of the externally applied pilot tone is known and fixed.

See WinControl help file for details.

Failure relay

The single-pole changeover failure relay may be wired to a 'common fault' or other external fault monitoring system so that any fault condition detected by the IndustryAmp is immediately reported. The conditions which cause activation of the failure relay may be defined in WinControl, and may include any or all of: DSP/amplifier/Dante™ board faults, load monitoring, internal temperature sensing, fan operation, pilot tone detection, etc. See the WinControl Help files for full details.

If it is required to interface the IndustryAmp to impedance-sensing fault-monitoring equipment such as the AXYS® Cerberus, the failure relay contacts may be re-configured by moving an internal jumper. See "fig.5: Failure relay" on page 14 for connection details.

PRESETS

In addition to retaining all current parameters and settings in non-volatile memory so that the amplifier resumes the same operational status after a power failure, the IndustryAmp also has seven further internal memories (Presets), each of which may contain an alternative unit configuration. These Presets are normally accessed via WinControl, but any third-party control system capable of transmitting the AxysBridge control commands via UDP/IP. (e.g. Crestron, AMX, etc.) may also be used.

One of the Presets may be assigned as an Emergency Preset, and automatically loaded in the event of loss of network communication. In the case of Dante™ equipped models in life-safety systems, it is generally advisable to provide an analogue backup audio feed and configure the amplifier to switch to a Preset including this in the event of a network failure. See the WinControl Help files for full details.

DSP BYPASS

The IndustryAmp's DSP system is continually monitored for correct operation, and in the event of failure, both analogue inputs are connected directly to the inputs of all amplifier power stages. This failsafe bypass ensures that the primary audio inputs always feed the loudspeaker system, even in the event of a major failure. The conditions for bypass are configurable from WinControl Service version. By default, a 'DSP not running' condition triggers the bypass action.

As with all other internally-monitored amplifier functions, a DSP failure is reported to the WinControl server via Dante™ AxysBridge, as well as triggering the external failure relay (if configured to do so).

LOAD MONITORING

The amplifier channels are equipped with current-sensing load monitoring. This operates in the ultrasonic range, at 22 kHz.

For correct operation, the system must be calibrated with the normal loads connected to each amplifier channel to establish a reference load current. After calibration, any

partial or total failure of any of the loads (or cabling) will be registered as a deviation of load current from the reference level. Load monitoring enabling and calibration is carried out using WinControl. Failure of a load monitoring test may be set to trigger the failure relay, if wished. See the WinControl Help Files for further information.

AMPLIFIER PROTECTION

Surge protection

Each channel of the power amplifier stage is equipped with gas discharge surge protection devices connected between each output terminal (100 V, 70 V and 0 V) and ground. These are designed to withstand high-energy voltage spikes of up to 4 kV to protect the amplifier output devices from damage. The amplifier output stages also incorporate clamping diodes to provide protection from lower amplitude voltage spikes.

Power-on delay

When the IndustryAmp is powered-up, the amplifier output terminals are disconnected from the amplifier power stages themselves by internal relays for a short period, to allow the internal voltage rails to stabilise and prevent any unwanted surges from damaging the loudspeakers.

You will hear a click a few seconds after turning the amplifier on and the front panel Status LED will go from red to green; this is normal operation.

DANTE™ CONFIGURATION

The Dante™ card fitted to Models PB-400-DN and PB-800-DN is self-organising and requires no adjustments. However for configuring systems with multiples of PB-400-DN/PB-800-DN units, each amplifier must have been assigned a unique IP address. This, as well as the audio routing, is defined using Audinate's Dante™ Controller software application. For systems that incorporate one or more AXYS® WinControl Server PCs for system management, this application will be pre-installed on each computer.

This topic is beyond the scope of this manual, and further information can be found in the documentation related to the WinControl Server configuration.

APPENDIX

TECHNICAL SPECIFICATIONS

Full technical specifications on all models are available at: www.axystunnel.com;

MAINTENANCE AND WARRANTY INFORMATION

Maintenance

Maintenance should only be performed by qualified service personnel. In case of doubt always contact your dealer.

Warranty Information

This IndustryAmp is covered by Harman Professional's standard product warranty, and is subject to the terms and conditions of the warranty.

Please consult www.axystunnel.com for a full statement of warranty policy.

COMMON ANALOGUE GROUNDING ISSUES

Correctly connecting the IndustryAmp to ground has several benefits. A full discussion of the issues involved can be found at www.axystunnel.com;

Basic points to observe are:

1. Safety. The GND terminal of the PowerCon® mains connector provides a direct low impedance path from the metal parts of the chassis to ground. Always connect this terminal.

2. Reduction of RF emission. Although the IndustryAmp electronics are well shielded and external connections are decoupled to prevent RF emission from the internal high speed digital circuits, this protection will not work properly if the chassis is not connected to ground.

3. RF Immunity. RF currents induced in the signal cables by external RF fields are effectively shorted to chassis ground, provided that the cable screen (shield) is of sufficiently low impedance.

The pins with a \perp symbol on the audio line input connectors and the ambient SPL mic connector are connected internally directly to the chassis of the amplifier. These pins are for connecting the screen (shield) of the audio cables.

SOFTWARE AND FIRMWARE UPDATES

The AXYS® WinControl (User version) application is freely available and can be downloaded from the download area of our website; www.axystunnel.com. We advise installers, users and engineers to check our site regularly for updates. For further information about how to use WinControl please refer to the WinControl Help files.



www.axystunnel.com