



*CSMA Commercial Series*

**CSMA 180**  
**CSMA 1120**  
**CSMA 240**  
**CSMA 280**  
**CSMA 2120**

# Commercial Series Mixer-Amplifier **Operation Manual**

## **CSMA Mixer-Amplifiers**

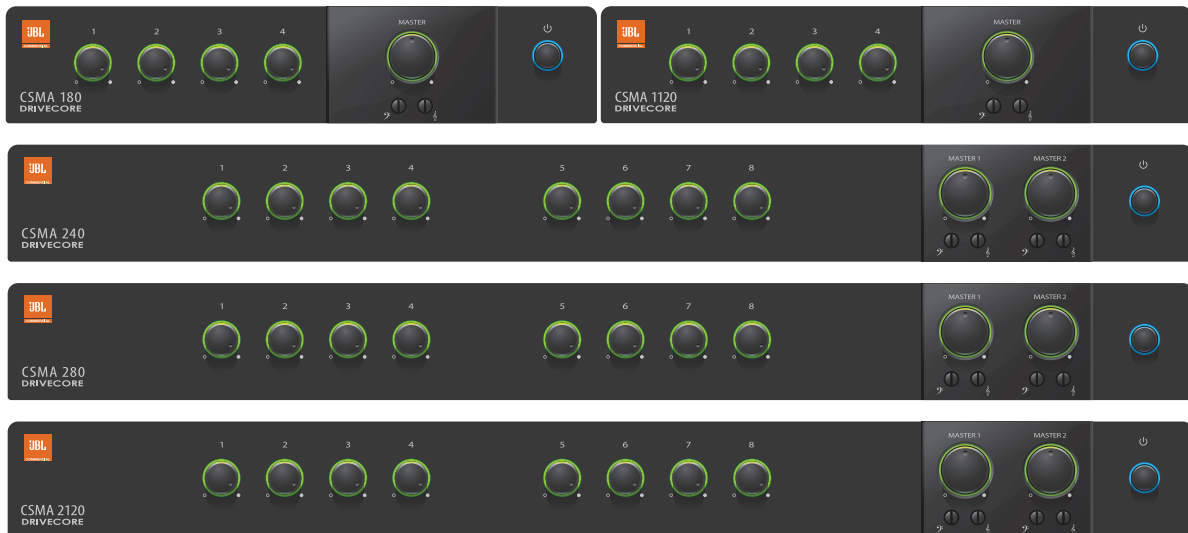

# Contents

Important Safety Instructions .....	3
JBL DECLARATION OF CONFORMITY .....	5
1.0 Welcome .....	7
1.1 Features .....	7
1.2 Front Control Panels and Indicators .....	8
1.3 Rear Panel Controls and Connectors - Four Channel.....	9
1.4 Rear Panel Controls and Connectors - Eight Channel.....	10
2.0 Setup .....	12
2.1 Unpacking Your Amplifier .....	12
2.2 Installing Your Amplifier .....	12
2.3 Ensuring Proper Cooling .....	17
2.4 Choosing Input Wire and Connectors .....	17
2.5 Output Wiring and Connectors .....	18
2.6 Wiring Your Audio System .....	19
2.7 Connecting to AC Mains .....	20
2.8 Protecting Your Speakers .....	20
2.9 Startup Procedure .....	20
3.0 Operation .....	21
3.1 Precautions .....	21
3.2 Input Routing.....	22
3.3 High-Z Switch .....	22
3.4 Phantom Power .....	22
3.5 VOX Ducking .....	22
3.6 Priority Muting .....	23
3.7 Remote Volume Control .....	23
3.8 Sleep Mode .....	23
3.9 AUX Output .....	23
4.0 Troubleshooting .....	24
Appendix A: Target Performance Specifications .....	25
Appendix B: Block Diagram .....	26
Appendix C: Contact Information .....	28

This manual does not include all of the details of design, production, or variation of the equipment. Nor does it cover every possible situation which may arise during installation, operation or maintenance.

The information provided in this manual was deemed accurate as of the publication date. However, updates to this information may have occurred.

Trademark Notice: JBL is registered trademark of JBL International. Other trademarks are the property of their respective owners.

© 2013 JBL Commercial, 8760 South Sandy Parkway, Sandy, UT. All Rights Reserved.

# IMPORTANT SAFETY INFORMATION



**CAUTION**

RISK OF ELECTRIC SHOCK  
DO NOT OPEN



**ATTENTION:** RISQUE DE CHOQUE ELECTRIQUE - NE PAS OUVRIR

**WARNING:** TO REDUCE THE RISK OF FIRE OR ELECTRIC SHOCK DO NOT EXPOSE THIS EQUIPMENT TO RAIN OR MOISTURE

The symbols shown above are internationally accepted symbols that warn of potential hazards with electrical products. The lightning flash with arrowpoint in an equilateral triangle means that there are dangerous voltages present within the unit. The exclamation point in an equilateral triangle indicates that it is necessary for the user to refer to the owner's manual.

These symbols warn that there are no user serviceable parts inside the unit. Do not open the unit. Do not attempt to service the unit yourself. Refer all servicing to qualified personnel. Opening the chassis for any reason will void the manufacturer's warranty. Do not get the unit wet. If liquid is spilled on the unit, shut it off immediately and take it to a dealer for service. Disconnect the unit during storms to prevent damage.

### SAFETY INSTRUCTIONS

NOTICE FOR CUSTOMERS IF YOUR UNIT IS EQUIPPED WITH A POWER CORD.

**WARNING:** THIS APPLIANCE SHALL BE CONNECTED TO A MAINS SOCKET OUTLET WITH A PROTECTIVE EARTHING CONNECTION.

The cores in the mains lead are coloured in accordance with the following code:

GREEN and YELLOW - Earth    BLUE - Neutral    BROWN - Live

As colours of the cores in the mains lead of this appliance may not correspond with the coloured markings identifying the terminals in your plug, proceed as follows:

- The core which is coloured green and yellow must be connected to the terminal in the plug marked with the letter E, or with the earth symbol, or coloured green, or green and yellow.
- The core which is coloured blue must be connected to the terminal marked N or coloured black.
- The core which is coloured brown must be connected to the terminal marked L or coloured red.

This equipment may require the use of a different line cord, attachment plug, or both, depending on the available power source at installation. If the attachment plug needs to be changed, refer servicing to qualified service personnel who should refer to the table below. The green/yellow wire shall be connected directly to the units chassis.

CONDUCTOR		WIRE COLOUR	
		Normal	Alt
L	LIVE	BROWN	BLACK
N	NEUTRAL	BLUE	WHITE
E	EARTH GND	GREEN/YEL	GREEN

**WARNING:** If the ground is defeated, certain fault conditions in the unit or in the system to which it is connected can result in full line voltage between chassis and earth ground. Severe injury or death can then result if the chassis and earth ground are touched simultaneously.

### WARNING FOR YOUR PROTECTION READ THE FOLLOWING:

KEEP THESE INSTRUCTIONS

HEED ALL WARNINGS

FOLLOW ALL INSTRUCTIONS

THE APPARATUS SHALL NOT BE EXPOSED TO DRIPPING OR SPLASHING LIQUID AND NO OBJECT FILLED WITH LIQUID, SUCH AS VASES, SHALL BE PLACED ON THE APPARATUS

CLEAN ONLY WITH A DRY CLOTH.

DO NOT BLOCK ANY OF THE VENTILATION OPENINGS. INSTALL IN ACCORDANCE WITH THE MANUFACTURER'S INSTRUCTIONS.

DO NOT INSTALL NEAR ANY HEAT SOURCES SUCH AS RADIATORS, HEAT REGISTERS, STOVES, OR OTHER APPARATUS (INCLUDING AMPLIFIERS) THAT PRODUCE HEAT.

ONLY USE ATTACHMENTS/ACCESSORIES SPECIFIED BY THE MANUFACTURER.

UNPLUG THIS APPARATUS DURING LIGHTNING STORMS OR WHEN UNUSED FOR LONG PERIODS OF TIME.

Do not defeat the safety purpose of the polarized or grounding-type plug. A polarized plug has two blades with one wider than the other. A grounding type plug has two blades and a third grounding prong. The wide blade or third prong are provided for your safety. If the provided plug does not fit your outlet, consult an electrician for replacement of the obsolete outlet.

Protect the power cord from being walked on or pinched particularly at plugs, convenience receptacles, and the point where they exit from the apparatus.

Use only with the cart stand, tripod bracket, or table specified by the manufacture, or sold with the apparatus. When a cart is used, use caution when moving the cart/apparatus combination to avoid injury from tip-over. Refer all servicing to qualified service personnel. Servicing is required when the apparatus has been damaged in any way, such as power-supply cord or plug is damaged, liquid has been spilled or objects have fallen into the apparatus, the apparatus has been exposed to rain or moisture, does not operate normally, or has been dropped.



**POWER ON/OFF SWITCH:** For products provided with a power switch, the power switch DOES NOT break the connection from the mains.

**MAINS DISCONNECT:** The plug shall remain readily operable. For rack-mount or installation where plug is not accessible, an all-pole mains switch with a contact separation of at least 3 mm in each pole shall be incorporated into the electrical installation of the rack or building.

**FOR UNITS EQUIPPED WITH EXTERNALLY ACCESSIBLE FUSE RECEPTACLE:** Replace fuse with same type and rating only.

**MULTIPLE-INPUT VOLTAGE:** This equipment may require the use of a different line cord, attachment plug, or both, depending on the available power source at installation. Connect this equipment only to the power source indicated on the equipment rear panel. To reduce the risk of fire or electric shock, refer servicing to qualified service personnel or equivalent.

If connected to 240V supply, a suitable CSA/UL certified power cord shall be used for this supply.

# IMPORTANT SAFETY INFORMATION

## **U.K. MAINS PLUG WARNING**

A molded mains plug that has been cut off from the cord is unsafe. Discard the mains plug at a suitable disposal facility. NEVER UNDER ANY CIRCUMSTANCES SHOULD YOU INSERT A DAMAGED OR CUT MAINS PLUG INTO A 13 AMP POWER SOCKET. Do not use the mains plug without the fuse cover in place. Replacement fuse covers can be obtained from your local retailer. Replacement fuses are 13 amps and MUST be ASTA approved to BS1362.

## **ELECTROMAGNETIC COMPATIBILITY**

This device complies with part 15 of the FCC Rules and the Product specifications noted on the Declaration of Conformity. Operation is subject to the following two conditions:

- this device may not cause harmful interference, and
- this device must accept any interference received, including interference that may cause undesired operation.

Operation of this unit within significant electromagnetic fields should be avoided.

- use only shielded interconnecting cables.



If you want to dispose this product, do not mix it with general household waste. There is a separate collection system for used electronic products in accordance with legislation that requires proper treatment, recovery and recycling.

Private household in the 25 member states of the EU, in Switzerland and Norway may return their used electronic products free of charge to designated collection facilities or to a retailer (if you purchase a similar new one).

For Countries not mentioned above, please contact your local authorities for a correct method of disposal.

By doing so you will ensure that your disposed product undergoes the necessary treatment, recovery and recycling and thus prevent potential negative effects on the environment and human health.

## **MAGNETIC FIELD**

**CAUTION!** Do not locate sensitive high-gain equipment such as preamplifiers or tape decks directly above or below the unit. Because this amplifier has a high power density, it has a strong magnetic field which can induce hum into unshielded devices that are located nearby. The field is strongest just above and below the unit.

If an equipment rack is used, we recommend locating the amplifier(s) in the bottom of the rack and the preamplifier or other sensitive equipment at the top.



## EC - DECLARATION OF CONFORMITY

**Brand:** JBL  
**Equipment Type:** Commercial Audio Mixer-Amplifiers  
**Model names:** CSMA 180, CSMA 1120, CSMA 240, CSMA 280, CSMA 2120

**We, Harman International,** declare under our sole responsibility that the product, to which this declaration relates, is in conformity with the following standards.

Report No.	Description
EN 55103-1:2009	EMC Compatibility – Product Family Standard for Audio, Video, Audio-Visual and Entertainment Lighting Control Apparatus for Professional Use, Part 1: Emissions
EN 55103-1:2009	Magnetic Field Emissions – Annex A @ 10cm and 20cm
EN 61000-3-2:2005, AMD1:2008, & A2:2009	Limits for Harmonic Current Emissions (equipment input current less than or equal to 16A
EN 61000-3-3:2008	Limitation of Voltage Fluctuations and Flicker in Low-Voltage Supply systems Rated Current less than or equal to 16A
EN 55022:2010	Limits and Methods of Measurement of Radio Disturbance Characteristics of ITE: Radiated & Conducted, Class B Limits
EN 55103-2:2009	EMC Compatibility – Product Family Standard for Audio, Video, Audio-Visual and Entertainment Lighting Control Apparatus for Professional Use, Part 2: Immunity
EN 61000-4-2:2009	Electrostatic Discharge Immunity (Environment E2-Criteria B, 4k V Contact, 8k V Air Discharge)
EN 61000-4-3:2010 Ed 3.2	Radiated, Radio-Frequency, EMC Immunity (Environment E2, Criteria A)
EN 61000-4-4:2007	Electrical Fast Transient/Burst Immunity (Criteria B)
EN 61000-4-5:2006	Surge Immunity (Criteria B)
EN 61000-4-6:2006	Immunity to Conducted Disturbances Induced by Radio-Frequency Fields (Criteria A)
EN 61000-4-11:2004	Voltage Dips, Short Interruptions and Voltage Variation

### Safety Standard:

IEC 60065:2001 – 7th Ed., AMD1:2005, & AMD2:2010	Safety Requirements – Audio, Video, and Similar Electronic Apparatus
--	--

**Due to line current harmonics, we recommend that you contact your supply authority before connection.**

We certify that the product identified above conforms to the requirements of the EMC Council Directive 89/336/EEC as amended by 92/31/EEC, and the Low Voltage Directive 73/23/EES as amended by 93/68/EEC.

### European Representative's Name and Address:

David Budge  
 10 Harvest Close  
 Yateley, GU46 6YS  
 United Kingdom

### Responsible for the technical documentation is:

Wilson Zhou  
 Wilson.Zhou@harman.com



## 1.0 Welcome

The JBL® CSMA series of Mixer-Amplifiers are a professional tool designed and built for Installed sound applications. There are both single channel and two channel models with four or eight mixer channels, respectively. They provide mixer capability with independent level control for each input channel and amplification with a choice of low impedance, 70V or 100V outputs.

The product includes a rack mounting kit for installations to a cabinet. The system can be easily expanded with additional JBL Commercial Series Amplifiers and Commercial Series Mixers. Provisions are included for a remote volume control using the JBL CSR-V control module.

### 1.1 Features

- 4 or 8 inputs with 1 or 2 outputs, respectively
- Ideal for commercial and industrial use
- System may be expanded by adding JBL Commercial Series Mixers or Commercial Series Amplifiers.
- Euro-block type mic/line input connectors and output connectors
- Independent Bass and Treble controls for each output channel
- VOX ducking during announcements
- Remote volume control capability using JBL CSR-V module and standard ethernet cable
- Priority muting using PTT switch closure
- Configurable output routing
- Utilizes Crown's DriveCore™ technology providing excellent audio performance with high efficiency
- 3 Year Warranty

\*Warranty is only valid within the United States of America. For information on Warranty outside of the U.S.A, please contact your local distributor.

## 1.2 Front Panel Controls and Indicators

Figure 1.2 Front View

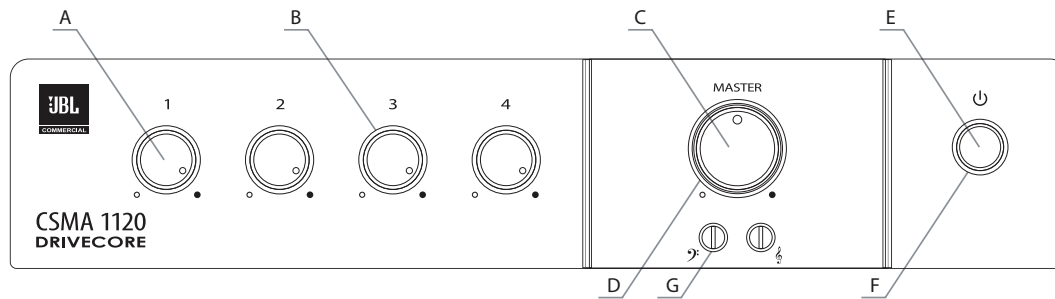

- A. Input Level Controls
- B. Input signal presence is indicated by green illumination of the ring around the input level controls
- C. Output Volume Controls
- D. Illuminated ring around the output volume control will light green with signal presence while red indicates clipping, i.e. the signal has reached the threshold of audible distortion.
- E. Power Switch
- F. Illuminated ring around the power switch. Green indicates that the unit is connected to the AC mains and is in standby or sleep mode. Blue indicates that the unit is on and in normal operating mode.
- G. Tone Controls - Bass  $\text{♩}$  and Treble  $\text{♩}$  potentiometers on each output channel



## 1.3 Rear Panel Controls and Connectors - Four Channel

Figure 1.3 Rear View - CSMA 1120

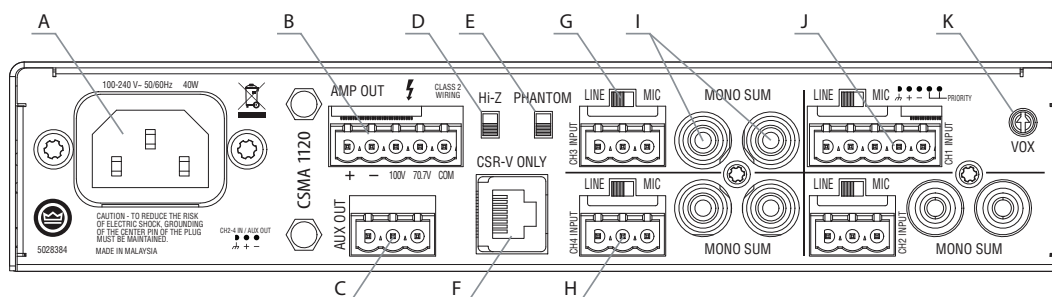

- A. AC Power Inlet – Detachable IEC
- B. Amplifier Output Connector
- C. Auxiliary Line Level Output Connector
- D. Hi-Z Switch – Enables the 70V and 100V outputs and activates the 70Hz high pass filter
- E. Phantom Power Switch – Applies 27V phantom power source for microphones.
- F. Remote volume connector – RJ-45 style connector to connect to JBL CSR-V control module
- G. Mic/Line Selection Switch – Allows the user to select the gain depending upon the source used
- H. Mic/Line Input Connector – 3 pin Euro-block connector, balanced input (Ch2-4)
- I. Dual RCA Input Connector – Stereo, unbalanced sources will be summed together (Ch2-4)
- J. Priority Input Connector – 5 pin Euro-block includes 3 pins for a balanced input as well as two pins that, when shorted together, activates the priority function. (Ch1)
- K. VOX Adjustment – allows the input level to be set that will invoke priority override. (CH1)

## 1.4 Rear Panel Controls and Connectors - Eight Channel

Figure 1.4 Rear View - CSMA 2120

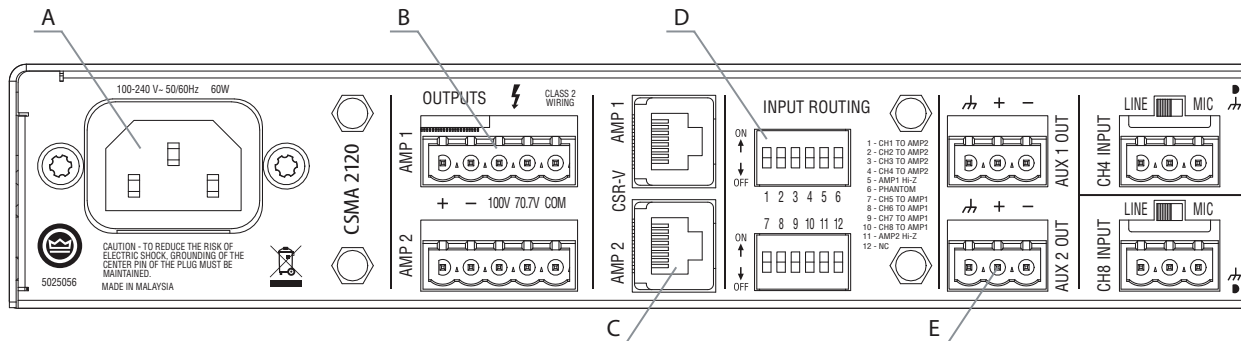

- A. AC Power Inlet – Detachable IEC
- B. Amplifier Output Connector – Outputs available for low impedance or constant voltage systems.
- C. Remote Volume Control – RJ45 style connector to connect to a JBL CSR-V control module.
- D. Dip switches for input routing, phantom power, and 70/100V operation
- E. Aux Out – Auxiliary line level output connector for each output channel.

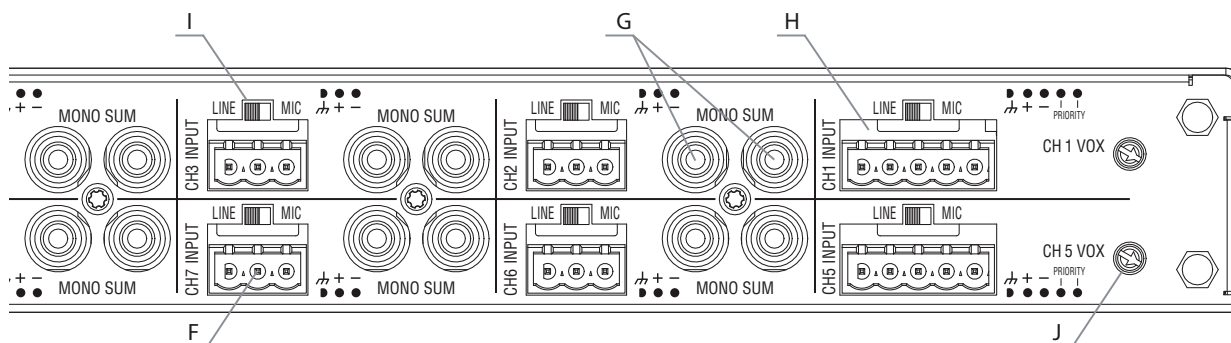

- F. Mic/Line Input Connector – 3 pin Euro-block connector for a balanced input source. (Ch 2-4 & 6-8)
- G. Dual RCA Input Connector – Stereo, unbalanced sources will be summed together. (Ch 2-8)
- H. Priority Input Connector – 5 pin Euro-block includes 3 pins for a balanced input as well as two pins that, when shorted together, activates the priority function. (Ch 1 & 5)
- I. Mic/Line Selection Switch – Allows the user to select the gain depending upon the source used.
- J. VOX Adjustment – Allows the input level to be set that will invoke priority override. (Ch 1 & 5)

## 2.0 Setup

### 2.1 Unpacking Your Amplifier

Please unpack and inspect your amplifier for any damage that may have occurred during transit. If damage is found, notify the transportation company immediately. Only you can initiate a claim for shipping damage. We will be happy to help as needed. Save the shipping carton as evidence of damage for the shipper's inspection.

We also recommend that you save all packing materials so you will have them if you ever need to transport the unit. Never ship the unit without the factory pack.

**WARNING:** Before you start to set up your amplifier, make sure you read and observe the Important Safety Instructions found at the beginning of this manual.

### 2.2 Installing Your Amplifier

**CAUTION:** Before you begin, make sure your amplifier is disconnected from the power source and all level controls turned completely down (counterclockwise).

Note: We recommend that any sensitive equipment be located at least 8 inches (20cm) away from the amplifier.

To install the amplifier, you can use one of the following approaches:

- Rack mount the amplifier with the rack mounting kit, see Figure 2.2.2.
- Place a single amplifier on a surface with 12 inches of air space around the unit for convection cooling. Rubber feet are included and can be attached onto the underside of the chassis. For amplifier dimensions, see Figure 2.2.1.

Figure 2.2.1 Dimensions

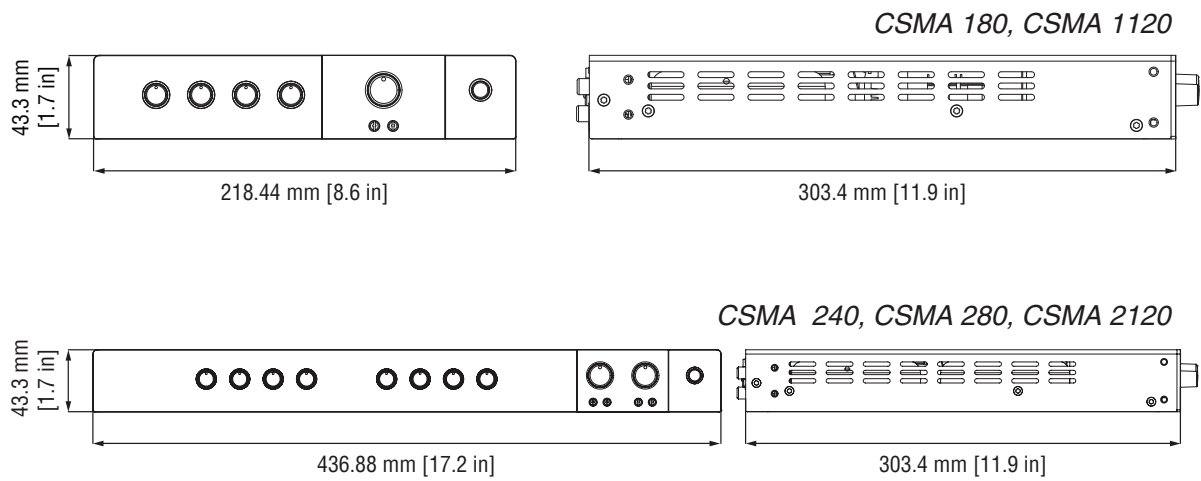

Figure 2.2.2 Mounting Kit

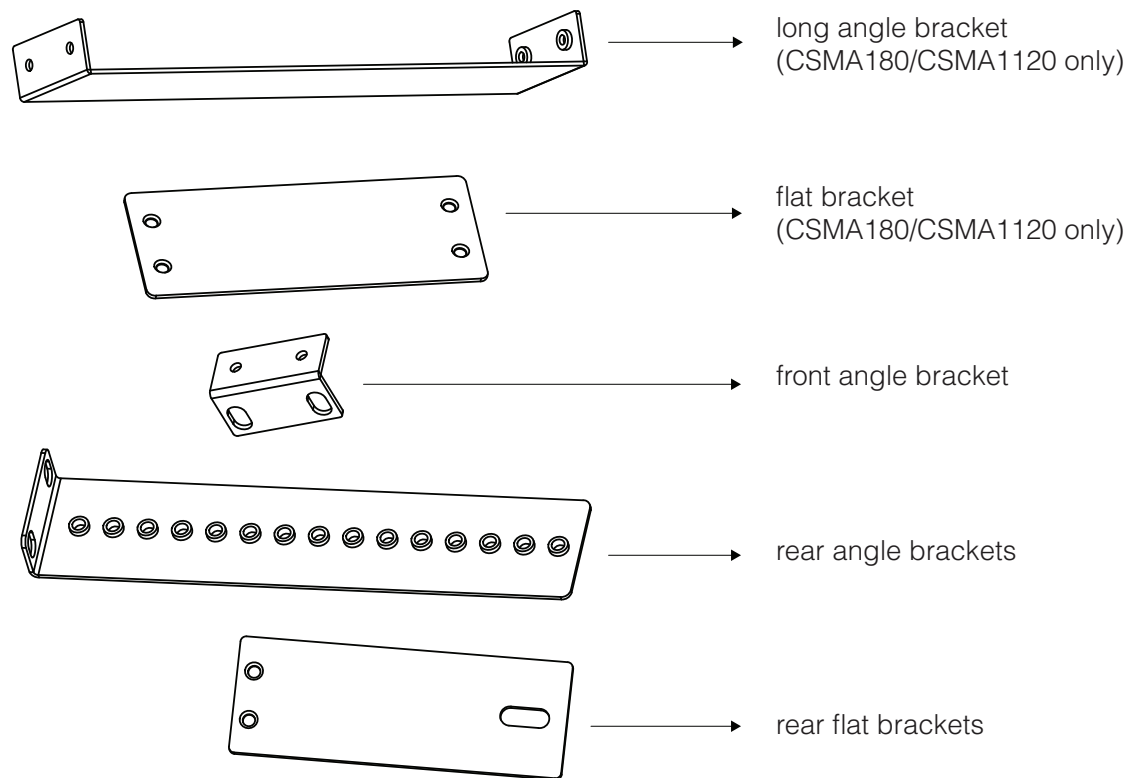
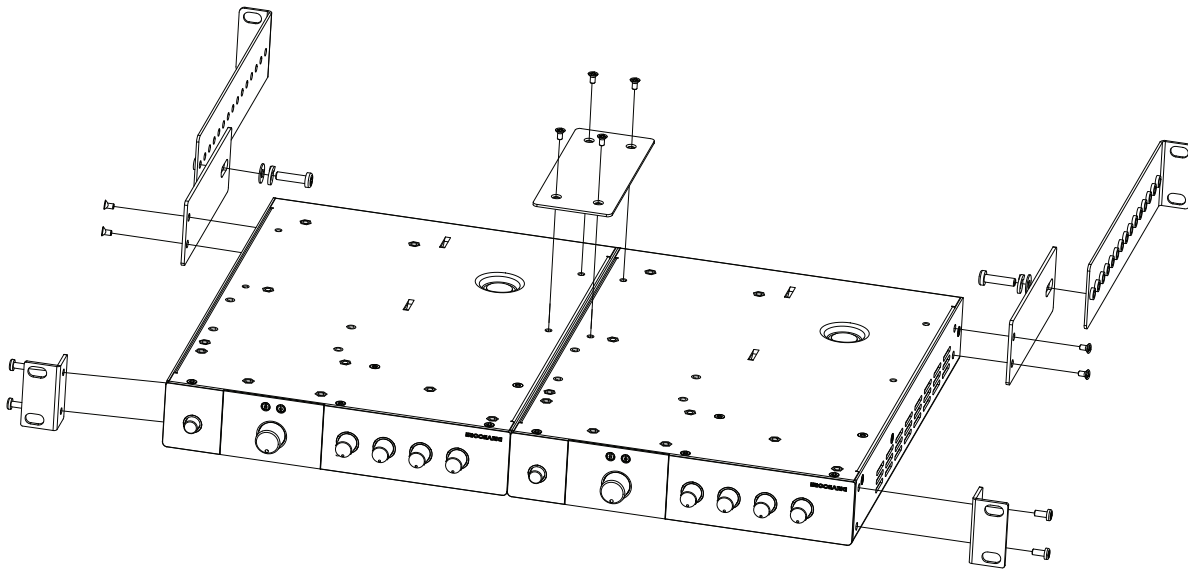

Figure 2.2.3 Rack mounting of two half rack Mixer units.



### **Solution A: Rack Mounting Two Half Rack Mixer Amplifiers**

To install two half-rack width units in your cabinet system, refer to Figure 2.2.3 and follow the steps below:

1. Align two modules side by side and upside down with the front panel towards the same direction.
2. Connect them with the flat bracket using the screws provided.
3. Attach the front angle brackets to each side of the front of the amplifier assembly using the screws provided.
4. Attach the rear flat brackets to each side of the rear of the amplifier assembly with the screws provided.
5. Install the assembly into the cabinet using the rack mount screws through the front angle brackets. For details of installation in the chassis of the cabinet, refer to the user guide of your cabinet.
6. Align the rear angle brackets with the proper holes at the rear of the cabinet and attach using rack mount screws.
7. With the rear angle brackets to the outside of the flat brackets, attach them each using a screw passing through two washers, the rear flat bracket and the rear angle bracket as shown in the figure.

Figure 2.2.4 Rack Mounting a Half Rack Mixer Amplifier

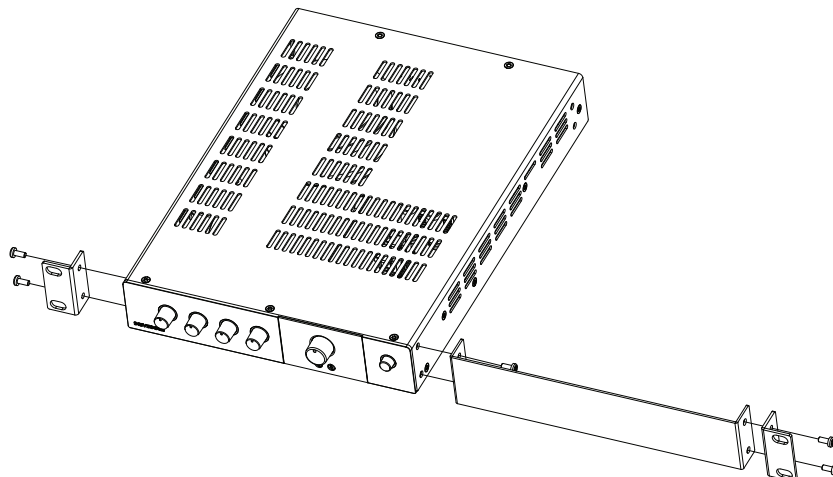

### **Solution B: Rack Mounting Single Half Rack Mixer Amplifier**

To install a single half-rack unit, refer to Figure 2.2.4 and follow the steps below:

1. Determine which side of the rack opening will be used for the amplifier and attach the long angle bracket to the other side at the front of the amplifier using the screws provided.
2. Attach the front angle brackets to each side of the front of the assembly, as shown in the diagram, with the screws provided.
3. Install the assembly into the cabinet using the rack mount screws through the front angle brackets. For details of installation in the chassis of the cabinet, refer to the user guide of your cabinet.

Figure 2.2.5 Rack Mounting Full Rack Mixer Amplifier

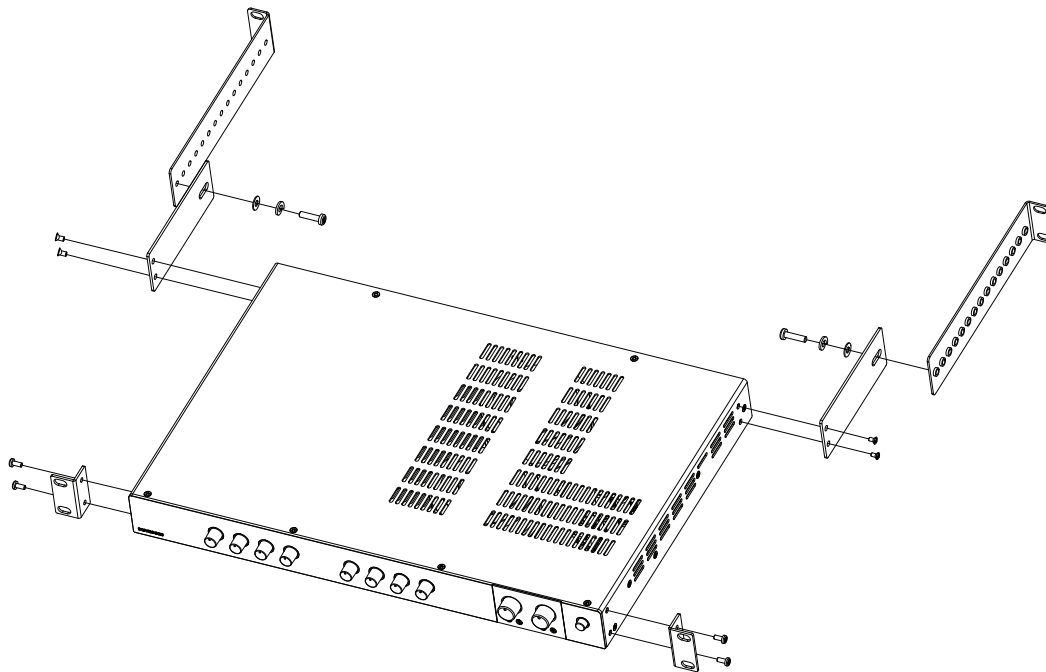

### **Solution C: Rack Mounting Full Rack Mixer Amplifier**

To install a full-rack width unit, refer to Figure 2.2.5 and follow the steps below:

1. Attach the front angle brackets to each side of the front of the amplifier using the screws provided.
2. Attach the rear flat brackets to each side of the rear of the amplifier with the screws provided.
3. Install the unit into the cabinet using the rack mount screws through the front angle brackets. For details of installation in the chassis of the cabinet, refer to the user guide of your cabinet.
4. Align the rear angle brackets with the proper holes at the rear of the cabinet and attach using rack mount screws.
5. With the rear angle brackets to the outside of the flat brackets, attach them each using a screw passing through two washers, the rear flat bracket and the rear angle bracket as shown in the figure.



## 2.3 Ensuring Proper Cooling

When using an equipment rack, keep a minimum space of 4 inches (10cm) from the top surface of the unit. Close any open spaces in the rack with blank panels. DO NOT block any air vents. The side walls of the rack should be a minimum of 2 inches (5 cm) from the amplifier sides. The back of the rack should be open.

## 2.4 Choosing Input Wire and Connectors

We recommend using pre-built or professionally wired balanced line (two-conductor plus shield) 22-24 gauge cables to connect the amplifier balanced input by using the included Euroblock connectors, see Figure 2.4. Unbalanced lines may be used, but may result in hum or RF noise very long cable runs.

You can also use RCA connectors to connect audio devices, for example, CD/DVD player. However, do not use both Euroblock and RCA audio input connectors on a single channel at the same time.

**NOTE:** Custom wiring should only be performed by qualified personnel.

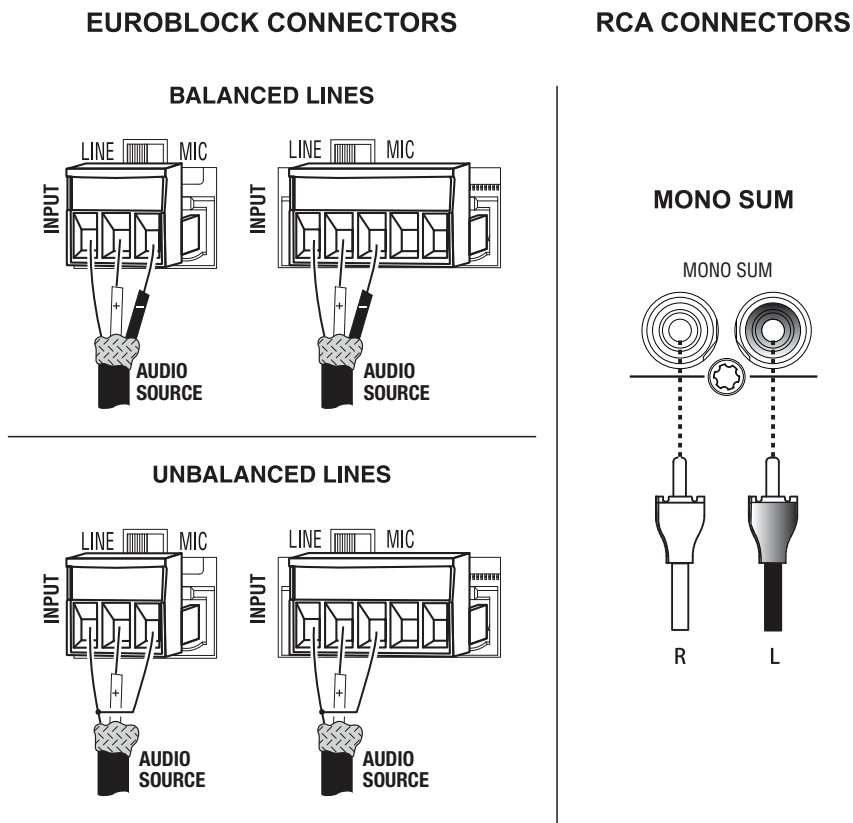

Figure 2.4.1 Input Wiring

**Note:** Two RCA connectors are provided for summing left and right channels from a stereo source. Do not use both Euroblock and RCA connectors concurrently for any single input channel.

## 2.5 Output Wiring and Connectors

To drive distributed speaker systems designed to operate at 70V or 100V, connect to the corresponding output terminals.

JBL recommends using pre-built or professionally wired, high-quality, two-conductor, heavy gauge speaker wire. Speakers wires should be twisted cable, if possible. To prevent the possibility of short-circuits, the wires should be stripped back no greater than 6 mm (1/4 inch), see Figure 2.5.2.

Suggested below are guidelines to select the appropriate size of wire based on the distance from amplifier to speaker. Check with local code as this may vary.

Distance	Wire Size
Up to 25 ft. (7.6m)	16AWG
26-40 ft. (7.9-12.2m)	14AWG

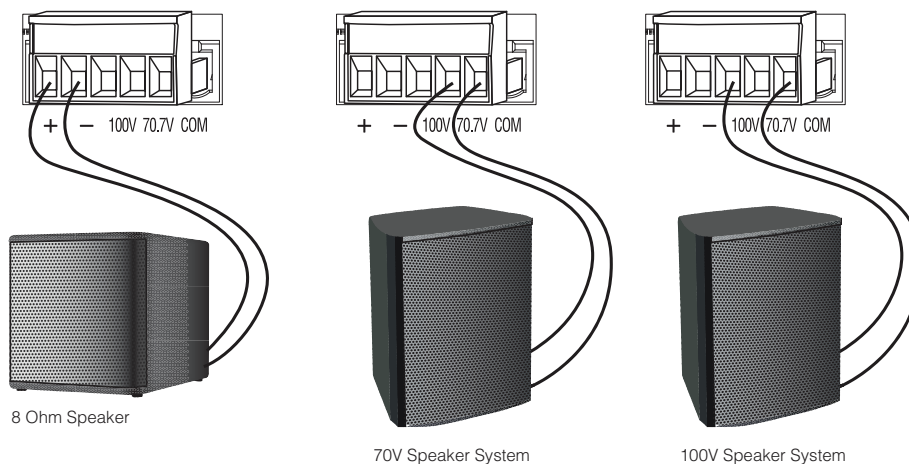

*Figure 2.5 Output Wiring*

Figure 2.6 Wiring Audio System

*Professional audio system*

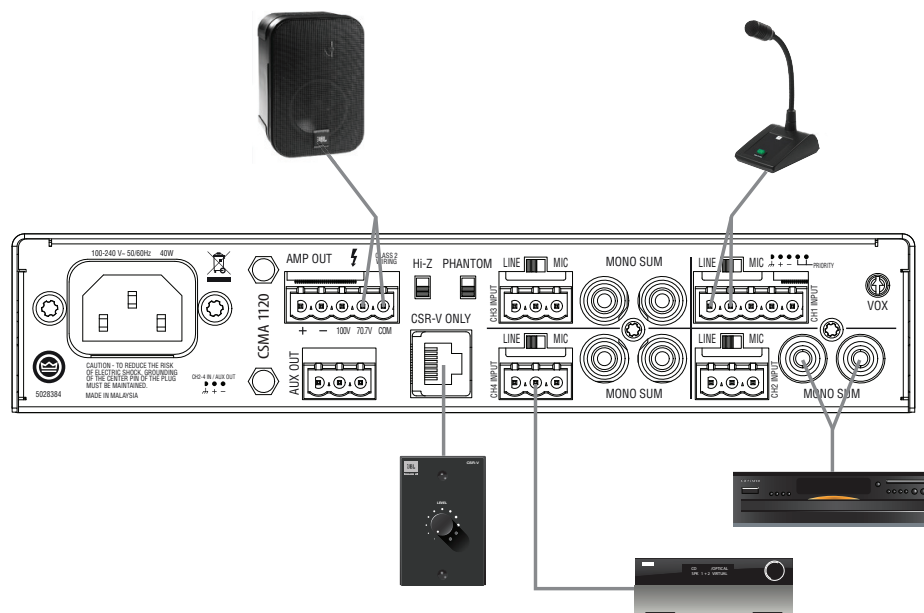

## 2.6 Wiring Your Audio System

Typical input and output wirings are shown in Figure 2.6.

**INPUTS:** Connect input wiring for both channels using either the RCA or the Euroblock input for each channel.

**OUTPUTS:** You may use either low impedance or high impedance speakers. Always be sure to maintain the proper polarity when wiring speakers.

Low Impedance Speakers should be driven using the +/- pins of the amplifier output connector. The minimum impedance an amplifier channel can drive is 4 Ohms. Therefore, you can connect up to four 16 Ohm speakers, two 8 Ohm speakers or one 4 Ohm speaker to an amplifier output channel.

High Impedance Speakers should be driven using the appropriate (70V or 100V) pin to speaker (+) and the COM pin to speaker (-) of the amplifier output connector. The minimum impedance that can be driven from each output is provided in Appendix A. Note that the HI-Z switch must be ON in order to provide audio to the high impedance outputs.

**WARNING:** Do not connect to both low impedance speakers and high impedance speakers from the same audio output channel.

## 2.7 Connecting to AC Mains

Connect your amplifier to the AC mains power source (power outlet) with the supplied AC power cord. First, connect the IEC end of the cord set to the IEC connector on the amplifier; then, plug the other end of the cord set to the AC mains. When properly connected to a live power source, the power ring should illuminate with a green color.

**WARNING:** The third prong of this connector (ground) is an important safety feature. Do not attempt to disable this ground connection by using an adapter or other methods.

Amplifiers don't create energy. The AC mains voltage and current must be sufficient to deliver the power you expect. You must operate your amplifier from an AC mains power source with not more than a 10% variation above or below the specified line voltage and within the specified frequency range indicated on the back panel of the amplifier. If you are unsure of the output voltage of your AC mains, please consult your electrician.

## 2.8 Protecting Your Speakers

It's wise to avoid clipping the amplifier signal. Not only does clipping sound bad, but it can damage high-frequency drivers. The built-in clip limiter prevents clipping.

Also, avoid sending strong subsonic signals to the amplifier. High-level, low-frequency signals from breath pops or dropped microphones can blow out drivers. You can switch to the HI-Z mode which, in addition to switching in the output transformers for 70V and 100V speakers, activates the high-pass filter. The filter prevents potentially damaging subsonic signals from going to the amplifier by eliminating signals below 70Hz.

## 2.9 Startup Procedure

Use the following procedure when first turning on your amplifier:

1. Turn down the level of your audio source.
2. Turn down the level controls of the amplifier.
3. Power up the amplifier. The Power ring should change from green to blue.
4. Turn up the level of your audio source to an optimum level.
5. Turn up the Level controls on the amplifier until the desired loudness or power level is achieved.

If you ever need to make any wiring or installation changes, don't forget to disconnect the power cord.

---

## 3.0 Operation

### 3.1 Precautions

Your amplifier is protected from internal and external faults, but you should still take the following precautions for optimum performance and safety:

1. Before use, your amplifier first must be configured for proper operation, including input and output wiring hookup. Improper wiring can result in serious operating difficulties.  
For information on wiring and configuration, please consult the Setup section of this manual.
2. Use care when making connections, selecting signal sources and controlling the output level.
3. Always be sure to have all levels at minimum when connecting or disconnecting audio sources from the inputs, especially when MIC is selected from the MIC/LINE switch. Failure to do so may cause the amplifier or speaker to go into a protection mode or even cause damage.
4. **WARNING:** Never connect the output to a power supply, battery or power main. Electrical shock may result.
5. Tampering with the circuitry, or making unauthorized circuit changes may be hazardous and invalidates all agency listings.
6. Do not operate the amplifier with the red Clip LEDs constantly flashing.
7. Do not overdrive the mixer, which will cause clipped signal to be sent to the amplifier. Such signals will be reproduced with extreme accuracy, and loudspeaker damage may result.
8. Do not operate the amplifier with less than the rated load impedance. Due to the amplifier's output protection, such a configuration may result in premature clipping and speaker damage.
9. Use the amplifier in a well-ventilated environment and do not use it in ambient temperature conditions in excess of 40°C. Failure to do so will result in the auto disconnection from power supply, and the overheat auto protection function will be activated. The power indicator will become green and there will not be any audio signal coming out of the amplifier. In this case, turn down the volume to the minimum, and the amplifier will soon resume working. When the amplifier returns to normal temperature the power indicator will return to blue and you may turn the volume up to a safe level.
10. If the line voltage to the amplifier is too low, the low voltage protection function will be activated. The power light ring will change from blue to green.

**CAUTION: JBL is not liable for damage that results from overdriving other system components.**

### 3.2 Input Routing

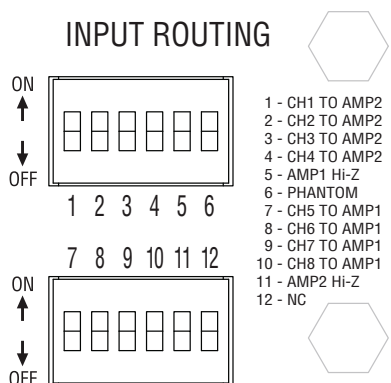

The two channel models, CSMA240, CSMA280 and CSMA2120 include a default routing of input channels 1-4 to amplifier 1 and input channels 5-8 to amplifier 2. The user may also take any input and have it routed to both outputs by selecting the appropriate switch. For example, if you set switch 1 to ON, it will be routed to both AMP1, and AMP2.

### 3.3 Hi-Z Switch

When this switch is in the “OFF” position, the amplifier is configured to drive low impedance speakers, (4 Ohms ,minimum) The Hi-Z switch will switch in the built-in output transformer allowing the unit to drive 70V or 100V speaker systems directly when connected to the appropriate output terminals. As an added feature when driving the high impedance speakers, the system automatically switches in a 70Hz high pass filter.

CSMA180 and CSMA1120 utilizes a slide switch labeled “HI-Z.” while the CSMA240, CSMA280 and CSMA2120 allows each amplifier output to be independently configured using the DIP switches #5 & #11.

### 3.4 Phantom Power

Phantom power (27V) can be applied to all mic inputs by turning on the Phantom Power switch. (DIP switch #6 on the CSMA240, CSMA280 & CSMA2120.)

### 3.5 VOX Function

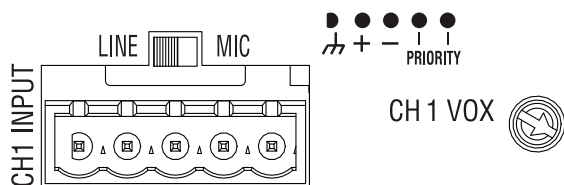

Voice activated ducking is available on input channel 1 of the CSMA180 and CSMA1120 and for both input channels 1 and 5 of the CSMA240, CSMA280 and CSMA2120. The audio input level required to activate ducking is set using the trim pot on the rear panel. Adjusting in the counter-clockwise direction will reduce that level while the full clockwise setting will disable the VOX function.

## 3.6 Priority Muting

With CSMA180 and CSMA1120 Input Channel 1 may be used as a priority channel, muting all other channels when pins 4 and 5 are shorted using a switch closure. If the amplifier has entered sleep mode due to inactivity, invoking priority will also bring the unit out of sleep and ready for transmitting an announcement.

The CSMA240, CSMA280 and CSMA2120 lets Input Ch1 operate with priority over all inputs into Amp 1. Ch1 will have priority over both Amp 1 and Amp 2 if the routing DIP switch #1 is set to ON. Ch5, however, cannot have priority over the Amp1 inputs.

## 3.7 Remote Volume Control

Remote volume control can be implemented using a CSR-V controller connected via an ethernet cable to the RJ45 connector on the back panel. For the CSMA240, CSMA280 and CSMA2120, there are two connectors, one for each amplifier output.

## 3.8 Sleep Mode

To save energy, the unit is designed to go into sleep mode after approximately 30 minutes operating with no signal at any of the inputs. Return of signal (-40dBu or 7.75mVRMS) to any input will wake the unit from its slumber. Also, a switch closure across the priority input pins will return the unit to normal operating mode.

## 3.9 AUX Output

An auxiliary output is available that you may connect to additional amplifiers. The audio signal is the mix of the input channels. Note that the master volume control and tone controls will have no effect on the aux output signal.

## 4.0 Troubleshooting

**CONDITION: No power to the mixer-amplifier so that the power ring is not illuminated.**

POSSIBLE REASON: The mixer-amplifier is not plugged into the power receptacle

**CONDITION: No sound or low sound.**

POSSIBLE REASON: The input signal is not present or at a very low level.

POSSIBLE REASON: The Master Volume control is turned down.

POSSIBLE REASON: A CSR-V is connected and turned down.

POSSIBLE REASON: Mixer channel inputs are turned down.

POSSIBLE REASON: The Ch 1 Priority switch is closed, muting all except Ch 1 input.

POSSIBLE REASON: The Hi-Z switch is OFF while using the 70V or 100V outputs.

POSSIBLE REASON: The power switch is OFF. (Note that while plugged in, the amplifier will be in standby mode and the power ring will be green until the power switch is activated and the power ring will turn blue.)

**CONDITION: Distorted sound.**

POSSIBLE REASON: Input signal level is too high. Please turn down the input level controls. Note that the mixer-amplifier should not be operated at a level that allows the clip indicator (red ring around the Master Volume) to be constantly ON.

POSSIBLE REASON: Master Volume is too high.

POSSIBLE REASON: MIC/LINE switch is in MIC position when using a line level source.



## Appendix A: Target Performance Specifications

Performance	CSMA 180	CSMA 1120	CSMA 240	CSMA 280	CSMA 2120
<b>Max Output Power per Channel</b> into 4 Ω or 8 Ω; 1kHz, ≤ 0.5% THD	80W	120W	40W	80W	120W
<b>Insertion Loss</b> (70V & 100V outputs)	1 dB maximum				
<b>Continuous Power per Channel</b>	10W	15W	5W	10W	15W
<b>Number of Input Channels</b>	4	4	8	8	8
<b>Number of Output Channels</b>	1	1	2	2	2
<b>Line Output level</b>	5.0V <sub>RMS</sub> into 10kΩ				
<b>Input Sensitivity</b> to obtain full rated power at 8 Ω (or 5V <sub>RMS</sub> to line out)	Mic Input: 3mV <sub>RMS</sub> Line Input: 775 mV <sub>RMS</sub> RCA Input: 300mV <sub>RMS</sub>				
<b>Frequency Response</b> (measured at 2.83V <sub>RMS</sub> into rated load impedance at any output)	4/8 Ohm Output: 20Hz - 20kHz, +/-2dB 70V/100V Outputs: 80Hz - 15kHz +/-2dB Line Out: 20Hz - 20kHz, +/-1dB				
<b>Total Harmonic Distortion (THD)</b> (measured at 2.83V <sub>RMS</sub> into rated load impedance at any output)	Power Amp Output: <0.5%, 20Hz - 20kHz Line Output: 0.05% typical				
<b>Signal-to-Noise Ratio</b> (Ref. Rated Power, mixer levels @ min., master volume @ max. A-weighted)	>90dB				
<b>Input Impedance</b> (nominal)	Mic: 400 Ω Line: 20 kΩ (balanced) RCA: 50 kΩ				
<b>Phantom Power</b>	27VDC				
<b>Crosstalk</b> (reference rated power, volume at mid position, 1kHz)	-70 dB				
<b>Nominal AC Line Voltages</b>	100-240V, 50/60 Hz				
<b>Minimum Load Impedance</b> Low Impedance Output 70V Output 100V Output	4 Ω 60 Ω 120 Ω	4 Ω 40 Ω 80 Ω	4 Ω 120 Ω 240 Ω	4 Ω 60 Ω 120 Ω	4 Ω 40 Ω 80 Ω
<b>Operating Temperature/Humidity</b>	0°C to 35°C @ 95% R.H. (non-condensing)				
<b>Storage Temperature</b>	-20°C to 85°C				
<b>Dimensions &amp; Weight</b>					
<b>Net Weight (preliminary estimate)</b>	6.8 lb (3.1 kg)	7.1 lb (3.2 kg)	10.6 lb (4.8 kg)	11.9lb (5.4 kg)	12.1 lb (5.5 kg)
<b>Dimensions</b>	Width: 8.6 in. (218.5 mm) Depth: 11.9 in. (303.4 mm) Height: 1.7 in. (43.3 mm)		Width: 17.2 in. (436.9 mm) Depth: 11.9 in. (303.4 mm) Height: 1.7 in. (43.3 mm)		
<b>Shipping Weight</b>	9.9 lb (4.5 kg)	10.1 lb (4.6 kg)	13.9 lb (6.3 kg)	15.2 lb (6.9 kg)	15.5 lb (7.0 kg)

Note: For AC power draw and thermal dissipation information, please visit our website. [www.jblcommercialproducts.com](http://www.jblcommercialproducts.com)

# Appendix B : Block Diagram

Figure C CSMA 2120/280/240 Block Diagram

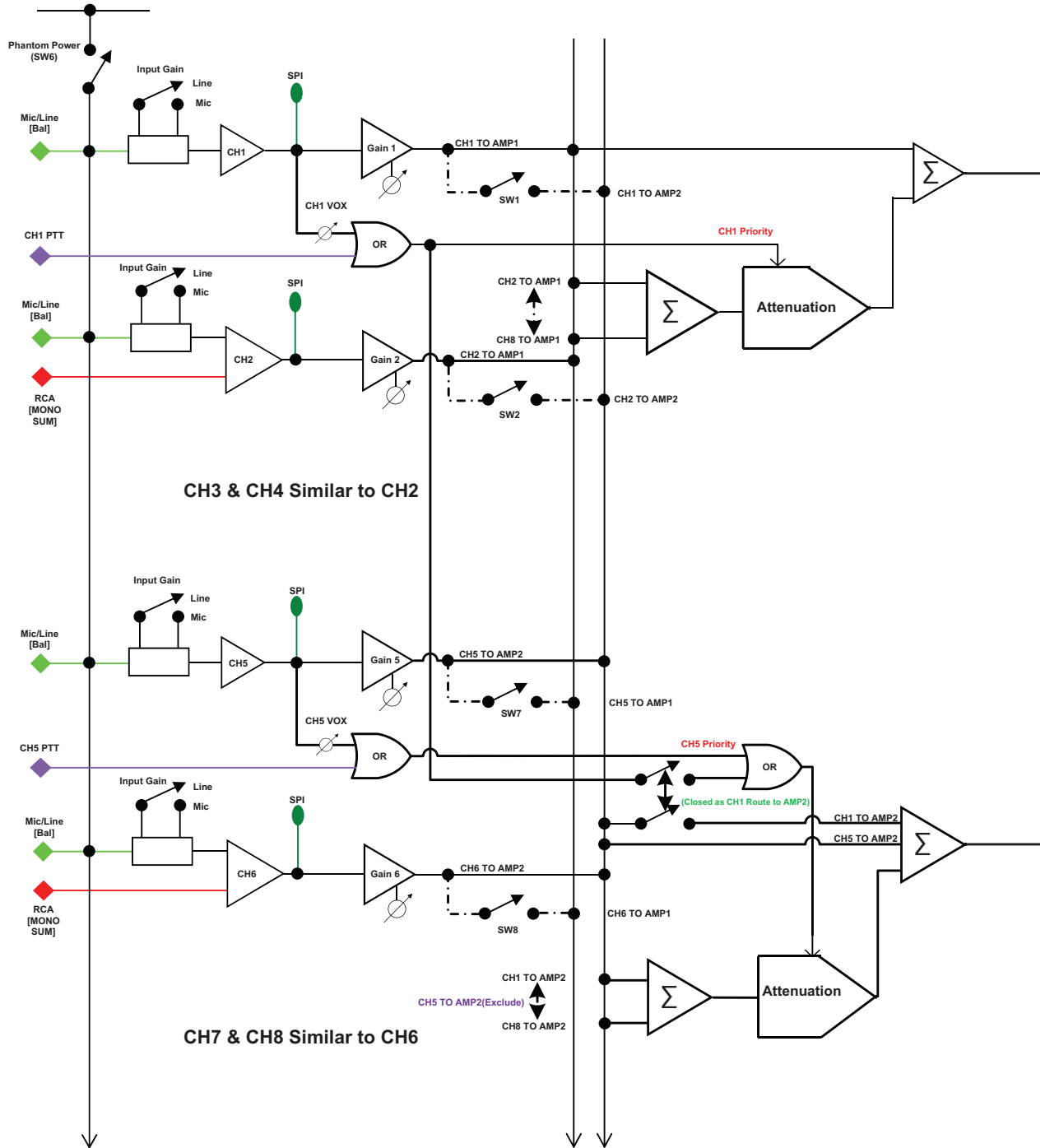

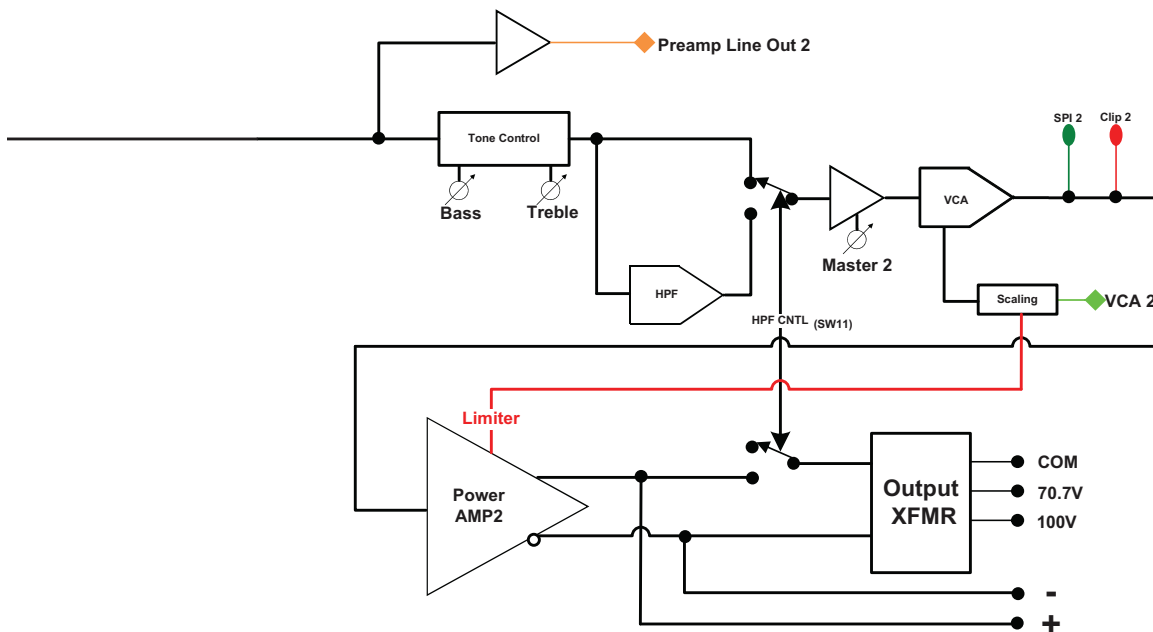
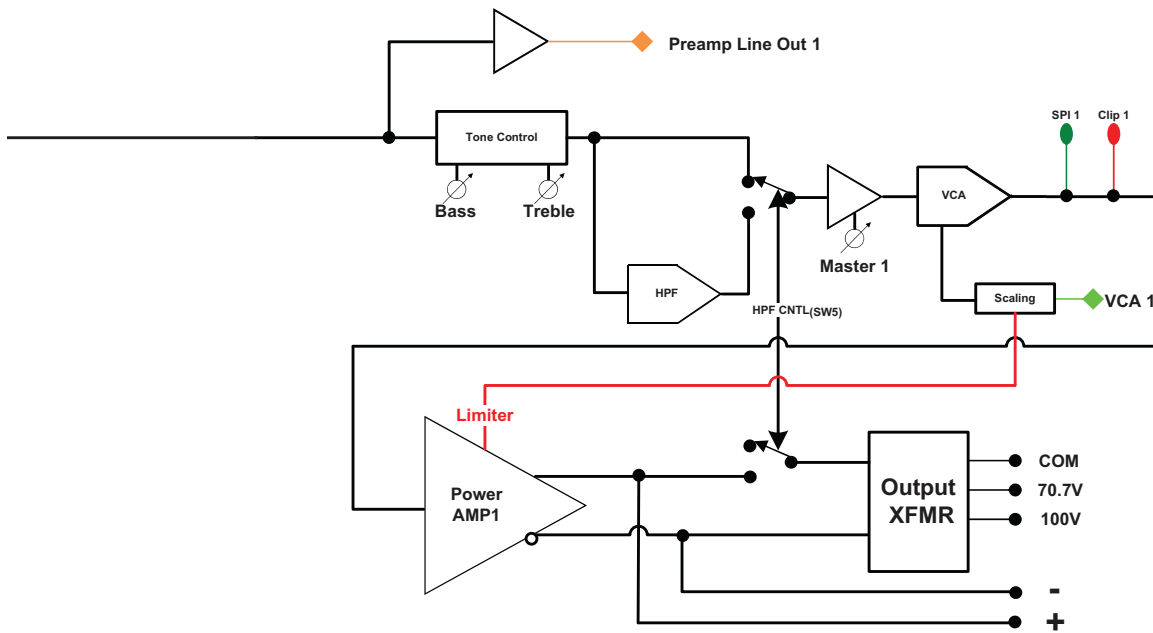

## **Appendix C: Contact Information**

For additional information, please consult JBL Professional Customer Service, your system installer or retailer.

### **On The World Wide Web:**

[www.jblcommercialproducts.com](http://www.jblcommercialproducts.com)

### **Professional Contacts, Outside the USA:**

Contact the JBL Professional Distributor in your area. A complete list of JBL Professional international distributors is provided at our U.S.A. Website: [www.jblpro.com](http://www.jblpro.com)



JBL Commercial  
8760 South Sandy Pkwy.  
Sandy, UT 84070 USA  
(801) 566-8800

Part Number: 5025072 Issue: 07/13



**CROWN**<sup>®</sup>  
by HARMAN

SYSTEM  
TECHNOLOGY  
BULLETIN

Crown Field Support Engineering

Issue Date: 6-MAY-2014

Ref. No: STB CSMA #0002

Subject: Selecting 70Volt operation mode.

**Applicability:** The following instructions will explain how to set the output (s) on the CSMA mixer amplifier to for 70 volt operation..

**Note:** *Default out of the box, the output(s) will be set for low impedance 8 ohm or 4 ohm operation.*

Step 1: 2-Channel CSMA. Locate the configuration dipswitches on the back of the Mixer/amplifier. DIPswitch #5 will set the output of Channel 1 to Hi-Z (high impedance) for 70volt or 100 volt operation. If the Unit is a 2 channel model, dipswitch #11 will set the output mode for amplifier Channel 2.

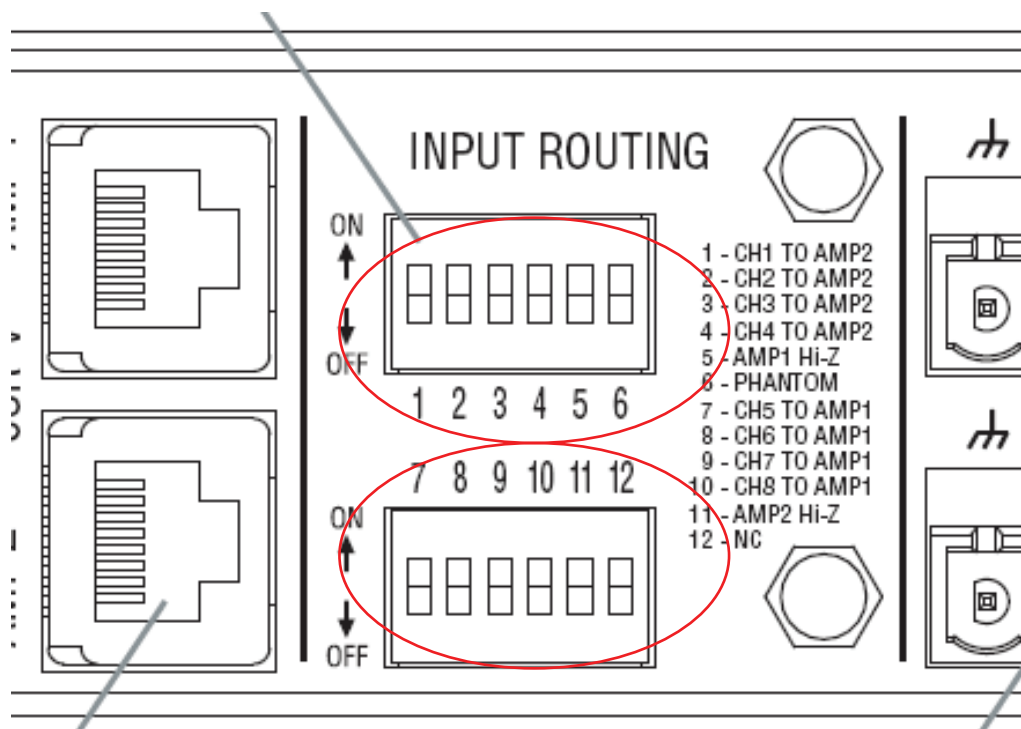



**CROWN**<sup>®</sup>  
by HARMAN

SYSTEM  
TECHNOLOGY  
BULLETIN

Step 2: 1-Channel CSMA. Locate the "Hi-Z" Configuration switch on the back of the mixer/amplifier. Turning this on will set the output of Channel 1 to Hi-Z or high impedance for 70volt or 100volt operation.



**Note:** Wire to appropriate terminals for configured output mode. 70volt mode shown in figure above.





**CROWN**<sup>®</sup>  
by HARMAN

SYSTEM  
TECHNOLOGY  
BULLETIN

*Crown Field Support Engineering*

**Issue Date:** 6-MAY-2014

**Ref. No:** STB CSMA #0001

**Subject:** Selecting Input Routing

**Applicability:** The following instructions will explain how to route inputs on the CSMA mixer amplifier to both output channels on the two channel version mixer amps.

**Note:** *Default out of the box, inputs 1 through 4 are routed to AMP 1 output and inputs 5 through 8 are routed to AMP 2 output.*

Step 1: Plug your audio source into the desired input channel. (For purposes of this note we will refer to input#1)

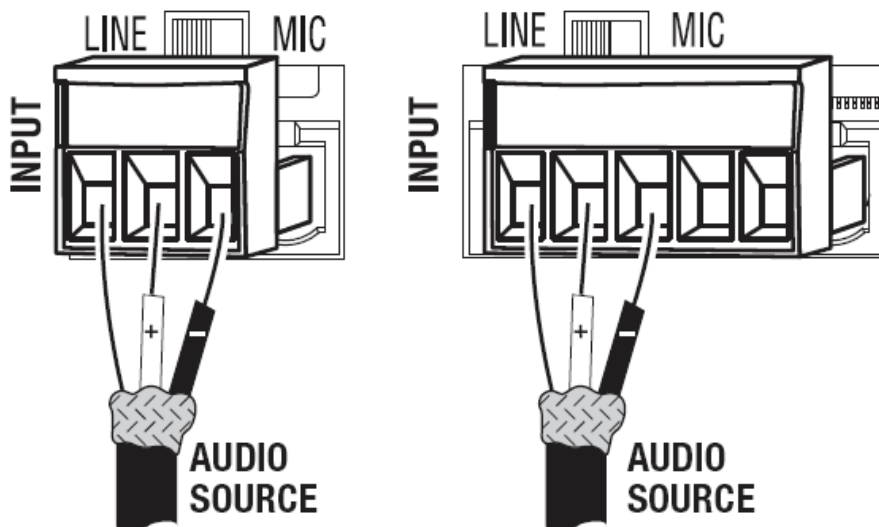

Step 2: Input #1 is automatically routed to AMP 1 output. Select the appropriate dipswitch to route Input #1 to AMP 2 output . This would be dip switch #1 as labeled on the back panel.





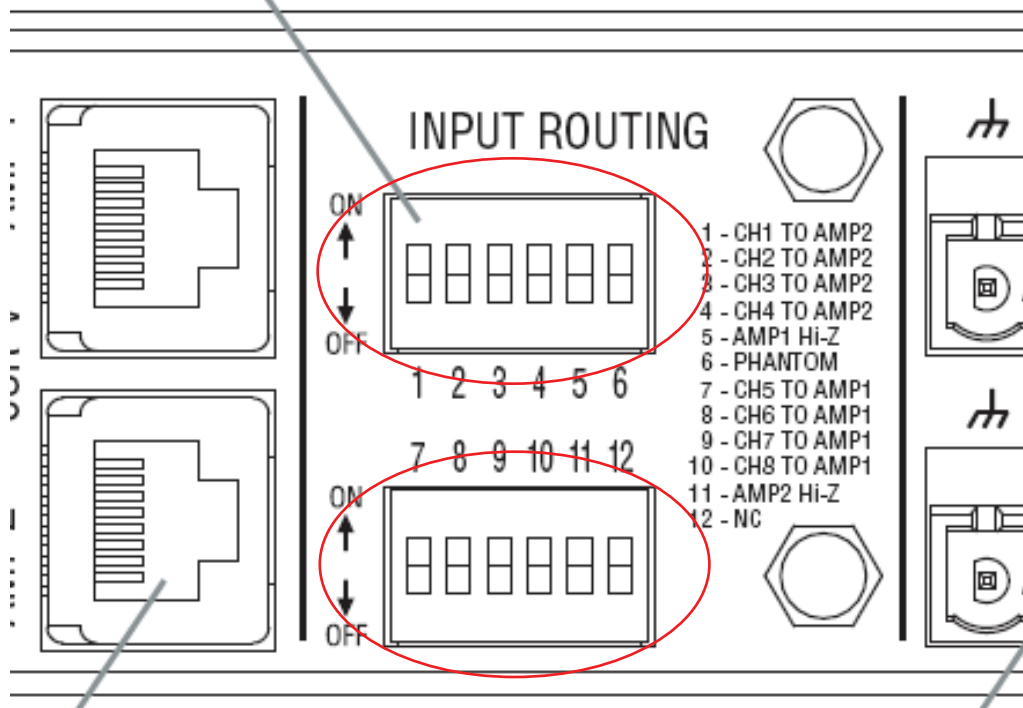

Step 3: Input #1 will now play on both AMP channel outputs and each output will maintain independent level control.

Step 4: Inputs 5 to 8 are set out of the box to only pass out AMP 2 output. To have any of these inputs also pass out AMP 1 output, dip switches 7 to 10 will route those inputs to AMP 1 output. Just flip the appropriate switch to the ON position and that input will also pass to AMP 1 output.



CSMA 2120																	
*1KHz sinewave, both channle driven		100 VAC/ 50 Hz				120 VAC/ 60 Hz				220 VAC/ 50 Hz				240 VAC/ 50 Hz			
Condition	Load	Line Current (Amps)	Power Dissipated as Heat			Line Current	Power Dissipated as Heat			Line Current (Amps)	Power Dissipated as Heat			Line Current	Power Dissipated as Heat		
			Watts	BTU	Kcal/hr		Watts	BTU	Kcal/hr		Watts	BTU	Kcal/hr		Watts	BTU	Kcal/hr
Idle (Sleep mode)			0.48	1.64	0.41		0.53	1.81	0.46		0.88	3.00	0.76		0.94	3.21	0.81
Idle (Awake)			15.70	53.54	13.50		15.90	54.22	13.67		17.46	59.54	15.02		17.80	60.70	15.31
1/8th rated power	8 ohms/ch	1.00	25.30	86.27	21.76	0.88	24.75	84.40	21.29	0.59	25.10	85.59	21.59	0.55	25.50	86.96	21.93
	4 ohm/ch	1.10	28.10	95.82	24.17	0.90	28.10	95.82	24.17	0.60	28.00	95.48	24.08	0.56	28.00	95.48	24.08
1/3rd rated power	8 ohms/ch	2.15	45.80	156.18	39.39	1.86	44.20	150.72	38.01	1.16	42.40	144.58	36.46	1.07	42.70	145.61	36.72
	4 ohm/ch	2.30	55.30	188.57	47.56	1.94	53.90	183.80	46.35	1.23	51.00	173.91	43.86	1.13	50.50	172.21	43.43
Full rated power	8 ohms/ch	5.36	131.00	446.71	112.66	4.91	125.20	426.93	107.67	2.89	118.00	402.38	101.48	2.70	110.00	375.10	94.60
	4 ohm/ch	6.14	196.00	668.36	168.56	5.51	175.70	599.14	151.10	3.25	168.00	572.88	144.48	3.04	135.00	460.35	116.10

CSMA 280																	
*1KHz sinewave, both channle driven		100 VAC/ 50 Hz				120 VAC/ 60 Hz				220 VAC/ 50 Hz				240 VAC/ 50 Hz			
Condition	Load	Line Current (Amps)	Power Dissipated as Heat			Line Current	Power Dissipated as Heat			Line Current (Amps)	Power Dissipated as Heat			Line Current	Power Dissipated as Heat		
			Watts	BTU	Kcal/hr		Watts	BTU	Kcal/hr		Watts	BTU	Kcal/hr		Watts	BTU	Kcal/hr
Idle (Sleep mode)			0.47	1.60	0.40		0.52	1.77	0.45		0.85	2.90	0.73		0.86	2.93	0.74
Idle (Awake)			14.64	49.92	12.59		14.92	50.88	12.83		16.40	55.92	14.10		16.60	56.61	14.28
1/8th rated power	8 ohms/ch	0.92	20.40	69.56	17.54	0.81	20.50	69.91	17.63	0.53	21.80	74.34	18.75	0.50	22.30	76.04	19.18
	4 ohm/ch	1.02	23.60	80.48	20.30	0.98	25.10	85.59	21.59	0.64	26.40	90.02	22.70	0.61	26.70	91.05	22.96
1/3rd rated power	8 ohms/ch	1.80	32.80	111.85	28.21	1.57	31.70	108.10	27.26	0.98	31.00	105.71	26.66	0.92	31.20	106.39	26.83
	4 ohm/ch	2.10	44.10	150.38	37.93	2.03	47.70	162.66	41.02	1.28	44.90	153.11	38.61	1.20	44.80	152.77	38.53
Full rated power	8 ohms/ch	4.35	91.30	311.33	78.52	3.87	89.50	305.20	76.97	2.46	76.00	259.16	65.36	2.29	74.00	252.34	63.64
	4 ohm/ch	6.13	195.00	664.95	167.70	5.86	206.80	705.19	177.85	3.50	152.10	518.66	130.81	3.30	148.70	507.07	127.88

CSMA 240																	
*1KHz sinewave, both channle driven		100 VAC/ 50 Hz				120 VAC/ 60 Hz				220 VAC/ 50 Hz				240 VAC/ 50 Hz			
Condition	Load	Line Current (Amps)	Power Dissipated as Heat			Line Current	Power Dissipated as Heat			Line Current (Amps)	Power Dissipated as Heat			Line Current	Power Dissipated as Heat		
			Watts	BTU	Kcal/hr		Watts	BTU	Kcal/hr		Watts	BTU	Kcal/hr		Watts	BTU	Kcal/hr
Idle (Sleep mode)			0.50	1.71	0.43		0.54	1.84	0.46		0.88	3.00	0.76		0.94	3.21	0.81
Idle (Awake)			12.95	44.16	11.14		13.31	45.39	11.45		15.40	52.51	13.24		15.70	53.54	13.50
1/8th rated power	8 ohms/ch	0.62	17.94	61.18	15.43	0.54	18.28	62.33	15.72	0.37	19.16	65.34	16.48	0.36	19.13	65.23	16.45
	4 ohm/ch	0.80	21.50	73.32	18.49	0.72	22.13	75.46	19.03	0.50	23.40	79.79	20.12	0.47	23.60	80.48	20.30
1/3rd rated power	8 ohms/ch	1.14	26.15	89.17	22.49	0.99	25.58	87.23	22.00	0.63	24.90	84.91	21.41	0.59	25.03	85.35	21.53
	4 ohm/ch	1.62	37.68	128.49	32.40	1.44	38.31	130.64	32.95	0.98	39.46	134.56	33.94	0.91	39.30	134.01	33.80
Full rated power	8 ohms/ch	2.92	97.10	331.11	83.51	2.45	61.70	210.40	53.06	1.47	55.70	189.94	47.90	1.39	55.30	188.57	47.56
	4 ohm/ch	4.49	132.70	452.51	114.12	3.99	127.40	434.43	109.56	2.61	122.60	418.07	105.44	2.41	121.00	412.61	104.06

CSMA 1120																	
*1KHz sinewave, both channle driven		100 VAC/ 50 Hz				120 VAC/ 60 Hz				220 VAC/ 50 Hz				240 VAC/ 50 Hz			
Condition	Load	Line Current (Amps)	Power Dissipated as Heat			Line Current	Power Dissipated as Heat			Line Current (Amps)	Power Dissipated as Heat			Line Current	Power Dissipated as Heat		
			Watts	BTU	Kcal/hr		Watts	BTU	Kcal/hr		Watts	BTU	Kcal/hr		Watts	BTU	Kcal/hr
Idle (Sleep mode)			0.44	1.50	0.38		0.48	1.64	0.41		0.82	2.80	0.71		0.89	3.03	0.77
Idle (Awake)			12.25	41.77	10.54		12.55	42.80	10.79		14.22	48.49	12.23		14.54	49.58	12.50
1/8th rated power	8 ohms/ch	0.57	15.90	54.22	13.67	0.52	16.00	54.56	13.76	0.38	17.00	57.97	14.62	0.36	17.30	58.99	14.88
	4 ohm/ch	0.64	16.50	56.27	14.19	0.55	17.20	58.65	14.79	0.39	17.70	60.36	15.22	0.37	18.10	61.72	15.57
1/3rd rated power	8 ohms/ch	1.09	24.10	82.18	20.73	0.96	23.50	80.14	20.21	0.65	23.20	79.11	19.95	0.60	23.60	80.48	20.30
	4 ohm/ch	1.23	28.50	97.19	24.51	1.05	28.00	95.48	24.08	0.70	27.30	93.09	23.48	0.67	27.70	94.46	23.82
Full rated power	8 ohms/ch	2.80	63.40	216.19	54.52	2.43	56.50	192.67	48.59	1.52	51.70	176.30	44.46	1.40	52.00	177.32	44.72
	4 ohm/ch	3.29	85.40	291.21	73.44	2.94	95.70	326.34	82.30	1.81	86.00	293.26	73.96	1.64	72.60	247.57	62.44

CSMA 180																	
*1KHz sinewave, both channle driven		100 VAC/ 50 Hz				120 VAC/ 60 Hz				220 VAC/ 50 Hz				240 VAC/ 50 Hz			
Condition	Load	Line Current (Amps)	Power Dissipated as Heat			Line Current	Power Dissipated as Heat			Line Current (Amps)	Power Dissipated as Heat			Line Current	Power Dissipated as Heat		
			Watts	BTU	Kcal/hr		Watts	BTU	Kcal/hr		Watts	BTU	Kcal/hr		Watts	BTU	Kcal/hr
Idle (Sleep mode)			0.45	1.53	0.39		0.48	1.64	0.41		0.80	2.73	0.69		0.90	3.07	0.77
Idle (Awake)			11.49	39.18	9.88		11.76	40.10	10.11		13.20	45.01	11.35		13.40	45.69	11.52
1/8th rated power	8 ohms/ch	0.48	15.20	51.83	13.07	0.43	15.60	53.20	13.42	0.32	16.50	56.27	14.19	0.30	16.80	57.29	14.45
	4 ohm/ch	0.66	16.80	57.29	14.45	0.56	17.00	57.97	14.62	0.39	17.80	60.70	15.31	0.36	18.20	62.06	15.65
1/3rd rated power	8 ohms/ch	0.86	20.00	68.20	17.20	0.76	19.40	66.15	16.68	0.51	19.80	67.52	17.03	0.48	20.10	68.54	17.29
	4 ohm/ch	1.26	28.50	97.19	24.51	1.06	28.00	95.48	24.08	0.68	27.30	93.09	23.48	0.63	27.50	93.78	23.65
Full rated power	8 ohms/ch	2.11	47.20	160.95	40.59	1.79	43.30	147.65	37.24	1.15	40.00	136.40	34.40	1.06	40.50	138.11	34.83
	4 ohm/ch	3.25	92.00	313.72	79.12	2.82	83.00	283.03	71.38	1.65	72.50	247.23	62.35	1.55	72.00	245.52	61.92