



CBT 100LA

Constant Beamwidth Technology™ Line Array Column Loudspeaker with Sixteen 50 mm (2 in) Drivers

CBT SERIES

Constant Beamwidth Technology™

Key Features:

- ▶ Patent-pending Constant Beamwidth Technology™ provides constant directivity up to the highest frequencies and reduces out-of-coverage lobing.
- ▶ Vertical pattern coverage switchable between 40° for medium-throw coverage and 15° for long-throw applications.
- ▶ Switchable voicing provides flat response in music mode or mid-range presence peak in speech mode.
- ▶ Dynamic SonicGuard™ overload protection
- ▶ Wall bracket included.
- ▶ Built-in 70V/100V transformer, plus 8 ohm direct capability.

Overview:

The CBT 100LA, with Constant Beamwidth Technology™, represents a breakthrough in pattern control consistency, utilizing complex analog delay beam-forming and amplitude tapering to accomplish superior, consistent vertical coverage without the narrow vertical beaming and out-of-coverage lobing that are typical of straight form-factor column speakers.

The slim, compact design fits well into virtually any architectural decor. The 100 cm (39.4 in) tall line array height provides consistent pattern control throughout the intelligibility band, making the CBT 100LA ideal for difficult acoustic environments. The combination of superior sound quality, excellent pattern control, and compact design makes CBT 100LA ideal for applications such as lecture halls, transit centers, conference rooms, cathedrals, multipurpose spaces, architectural spaces, and in-wall recessed locations, among many others.

The innovative coverage adjustability allows switching between broad and narrow vertical coverage settings to allow matching the coverage and throw requirements of the application. Coverage can be easily switched in-venue with the speaker already installed. This innovation allows a single loudspeaker model to excel in an extremely wide variety of project types.

The voicing can be set to match the application through the Music/Speech switch. The Music setting provides flat frequency response, while the Speech setting produces a mid-range presence boost to provide clear, intelligible speech even at the longest throw distances.

The drivers feature dual neodymium magnets for light weight. Copper capped pole pieces lower both the driver inductance and the flux modulation, resulting in increased high frequency extension and reduced distortion at high drive levels. Butyl rubber surrounds provide long life even in high humidity environments. The drivers are shielded.

Dynamic SonicGuard™ minimizes distortion at high drive levels by limiting low frequency excursion dynamically. This maximizes clarity at high drive levels while protecting the drivers from damage due to overpowering.

A wall-mount bracket is included, plus ten M6 inserts on the back panel fit the spacing of common third-party mounting brackets, or can be utilized to suspend the speaker using forged shoulder steel eyebolts, providing installation versatility.

CBT 100LA can be installed either indoors or outdoors. The drivers are weather-treated, the fiberglass reinforced ABS cabinet is excellent for outdoor applications, external screws are stainless steel screws, and the painted aluminum grille resists rusting in the harshest conditions.

Available in black or white (-WH).

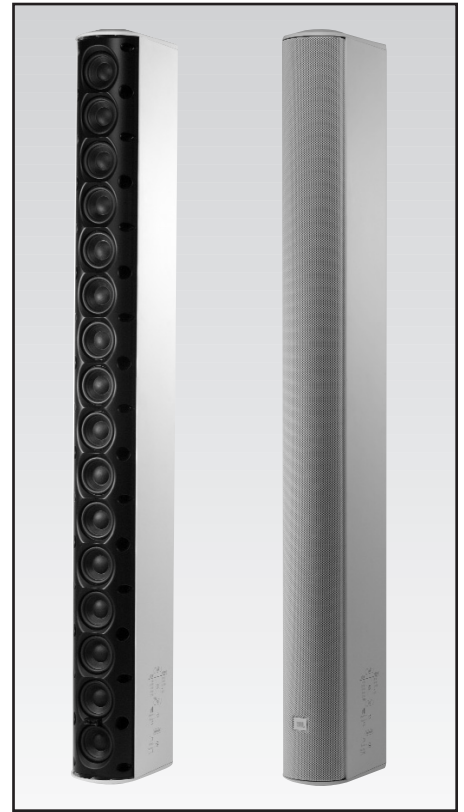

Specifications:

Components:	Sixteen 50 mm (2 in) Full-Range
Frequency Range (-10 dB):	80 Hz – 20 kHz
Vertical Coverage:	Vertical
	Narrow Mode: 15° (2 kHz - 16 kHz) (±10°)
	Broad Mode: 40° (1 kHz - 16 kHz) (±10°)
	Horizontal 150° (ave, 1 kHz – 4 kHz, ±20°)
Sensitivity (2.83V@ 1m):	Narrow: (speech mode) 96 dB (2 kHz - 14 kHz) (music mode) 93 dB (300 Hz - 18 kHz)
	Broad: (speech mode) 93 dB (2 kHz - 14 kHz) (music mode) 90 dB (300 Hz - 18 kHz)
Nominal Impedance:	8 ohms (in Thru mode)
Power Capacity (8 ohm setting):	325 W (1300W peak), 2 hrs 200 W (800W peak), 100 hrs
Max SPL:	Narrow: (speech mode) 121 dB cont ave (127 peak) (music mode) 118 dB cont ave (124 peak)
	Broad: (speech mode) 118 dB cont ave (124 peak) (music mode) 115 dB cont ave (121 peak)
70V/100V Transformer Taps:	120W, 60W, 30W, (15W at 70V only), and 8Ω thru, via switch
Enclosure:	Fiberglass reinforced ABS cabinet, painted aluminum grille
Outdoor Capability:	IP-54 rated, per IEC529. UV, moisture and salt-spray resistant
Colors:	Black or White (-WH)
Insert Points:	18 M6 insert points on back panel.
Mounting:	Included wall bracket provides continuously adjustable ±15 degree tilt, as well as 5 degree fixed increment points. Eighteen threaded mounting points located on back panel conform to industry standard rectangular 108 x 51 mm (4.25 x 2.0 in) pattern for third-party bracket, or can be utilized for suspension.
Dimensions (H x W x D):	1000 x 98.5 x 153 (39.4 in x 3.8 in x 6.0 in)
Net Weight:	7.2 kg (15.8 lb)
Included Accessories:	Wall bracket
Optional Accessories:	MTC-PC2 terminal panel cover

†Full space

‡IEC standard, full bandwidth pink noise with 6 dB crest factor.

§Calculated based on power rating and measured sensitivity, exclusive of power compression.

► CBT 100LA Line Array Column Loudspeaker with Sixteen 50 mm (2 in) Drivers

Broad Setting

Frequency Response:

“Music” Mode (solid); “Speech” Mode (dotted), 1W, 1m, and Impedance

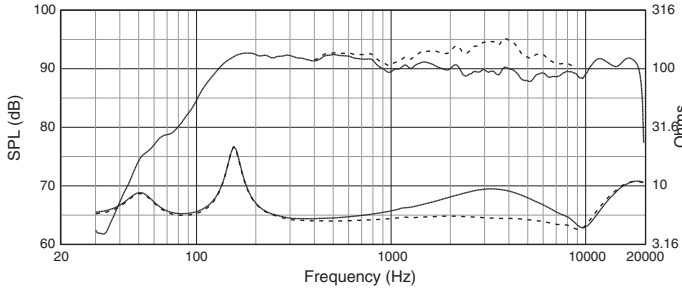

Beamwidth:

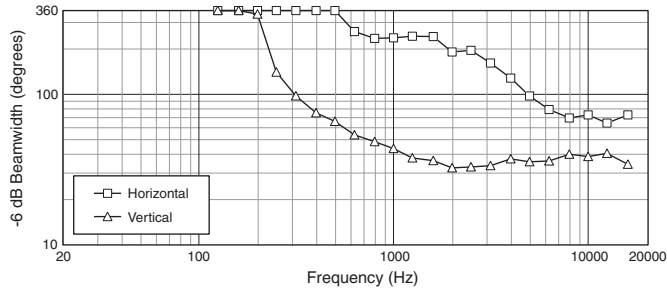

Directivity, Q

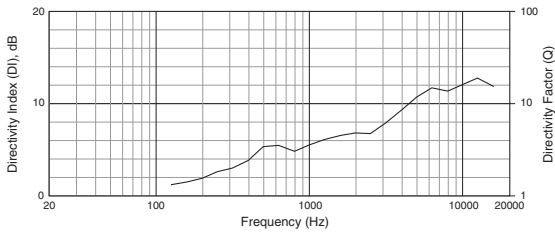

Vertical Off-Axis Frequency Response

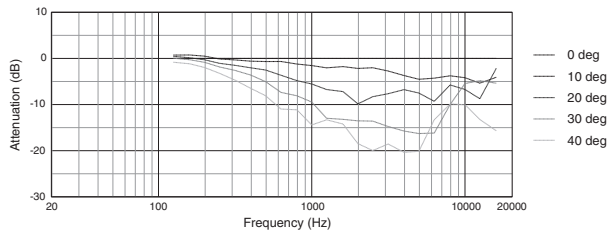

Horizontal Off-Axis Frequency Response

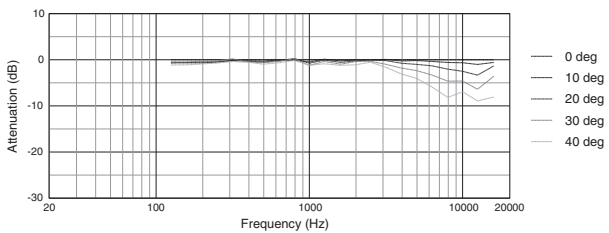

Narrow Setting

Frequency Response:

“Music” Mode (solid); “Speech” Mode (dotted), 1W, 1m, and Impedance

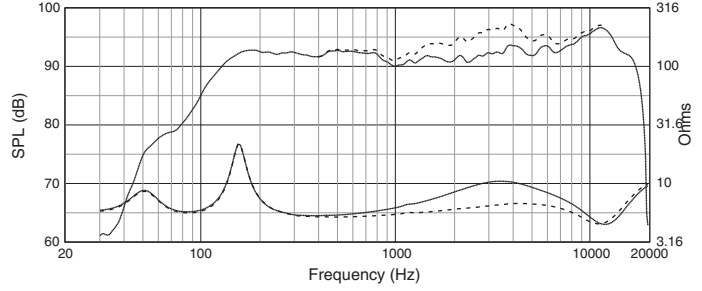

Beamwidth:

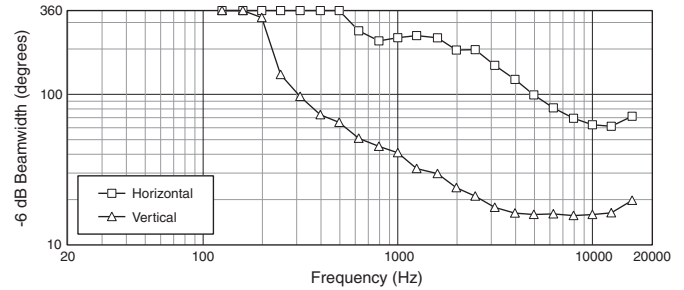

Directivity, Q

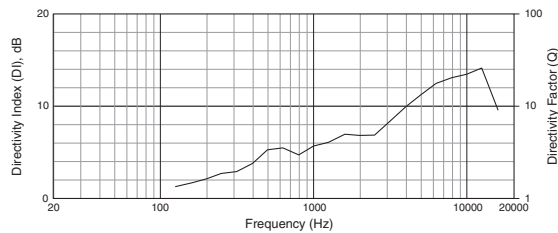

Vertical Off-Axis Frequency Response

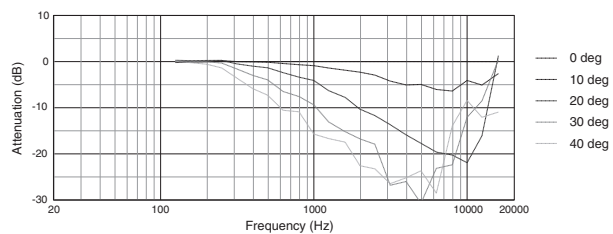

Horizontal Off-Axis Frequency Response

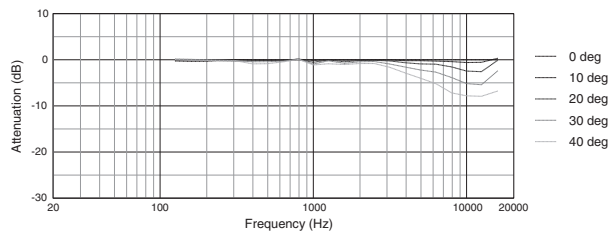

► CBT 100LA Line Array Column Loudspeaker with Sixteen 50 mm (2 in) Drivers

Broad Setting

Narrow Setting

Vertical 1/3 Octave Polars

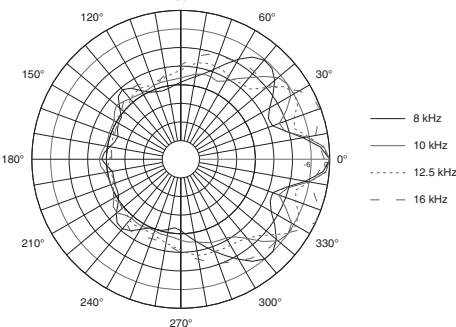
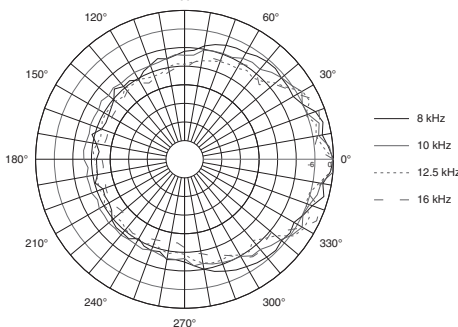
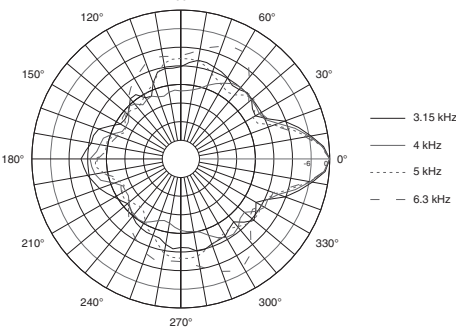
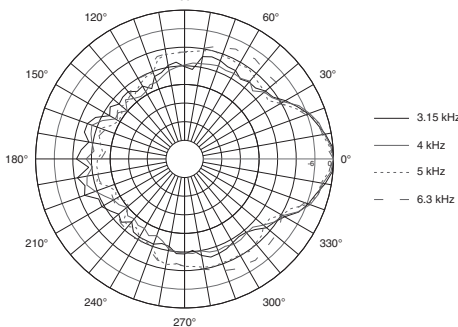
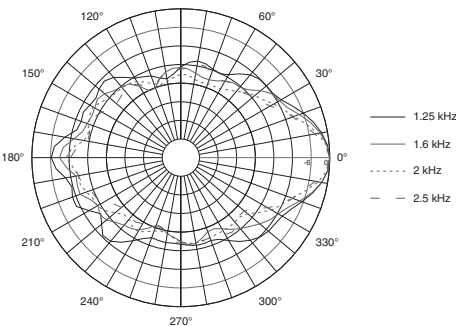
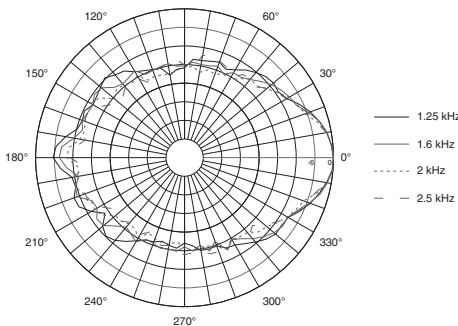
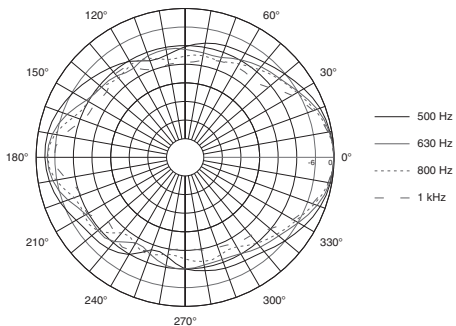
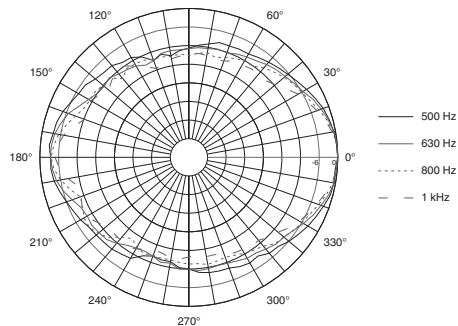
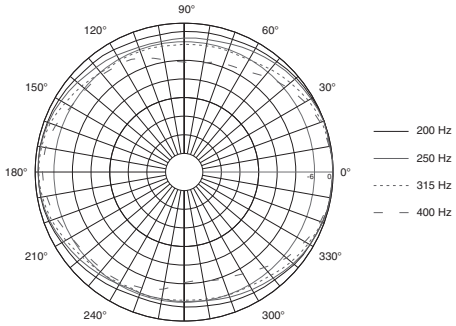
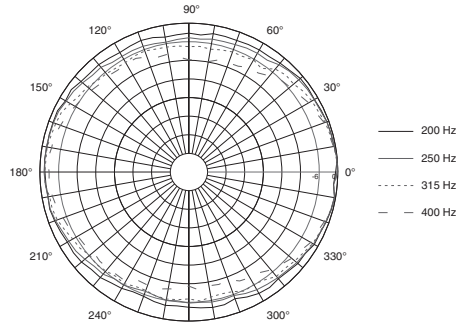

▶ CBT 100LA Line Array Column Loudspeaker with Sixteen 50 mm (2 in) Drivers



JBL Professional
8500 Balboa Boulevard, P.O. Box 2200
Northridge, California 91329 U.S.A.

H Harman International
© Copyright 2009 JBL Professional
www.jblpro.com

SSCBT100LA
CRP
06/09