

# PZM-11

The Crown PZM®-11 is a Pressure Zone Microphone® designed for security, surveillance, and conference-room applications. It can be mounted in the ceiling or wall in a standard electrical outlet box. Providing excellent intelligibility, the PZM-11 is designed to look like something other than a microphone so as not to draw attention.

Like other Pressure Zone Microphones, the PZM-11 utilizes the Pressure Recording Process™ in which a miniature condenser microphone capsule is mounted very close to a sound-reflecting plate or boundary. The capsule is mounted in the "Pressure Zone" just above the boundary, a region where sound coming directly from the sound source combines in-phase with sound reflected off the boundary. The benefits are a wide, smooth frequency response free of phase interference, excellent clarity and "reach," and consistent pickup anywhere around the microphone.

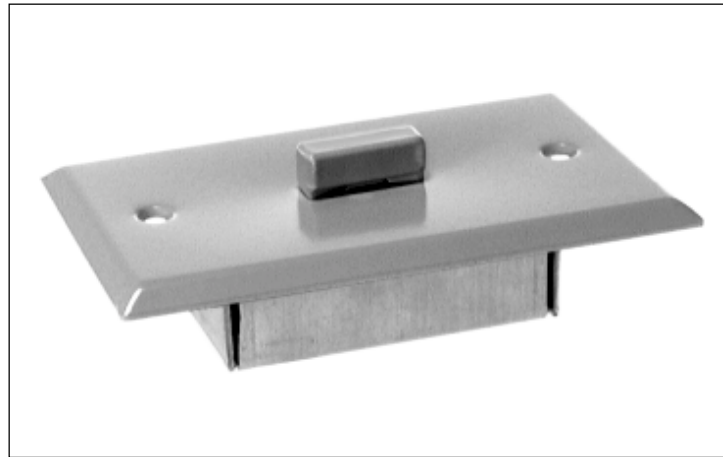
In the PZM-11, low frequencies below the voice range are rolled off to reduce pickup of air-conditioning rumble. The high-frequency response is boosted slightly to aid clarity and articulation.

The microphone connector is a row of screw terminals for easy installation. The output is balanced, low impedance, which allows long cable runs without hum pickup or high-frequency loss. Powering is via 12 to 48 volts phantom power.

## Installation

1. Please refer to Fig. 3 and locate all the parts shown.
2. Run a 2-conductor shielded microphone cable to the ceiling or wall hole where you intend to install the microphone. Install a standard electrical outlet box in the hole.
3. Run the mic cable through the hole in the electrical box and through the hole in the chassis.
4. Service the end of the mic cable.
5. Attach the leads to the screw terminals. Connect the cable shield to 1, light-colored lead to 2, and darker lead to 3.
6. Place the chassis over the two long screws. Using the nuts provided, secure the chassis to the faceplate.

## PRESSURE ZONE MICROPHONE®



### Specifications

**Type:** Pressure Zone Microphone.

**Element:** Electret condenser.

**Frequency response (typical):** 80 Hz to 20,000 Hz.  
See Fig. 1.

**Polar pattern:** Hemispherical.

**Impedance:** 225 ohms, balanced. Recommended minimum load impedance 1000 ohms.

**Open circuit sensitivity:** 5 mV/Pa\* (-46 dBV/Pa).

**Power sensitivity:** -45.5 dBm/Pa\*, EIA rating -139 dBm.

**Equivalent noise level (self-noise):** 26 dB SPL typical (0 dB = .0002 dyne/cm<sup>2</sup>), A-weighted.

**S/N Ratio:** 68 dB at 94 dB SPL.

**Maximum SPL:** 120 dB SPL produces 3% THD.

**Output connector:** Three screw terminals.  
1 = ground, 2 = audio (hot), 3 = audio (return).

**Polarity:** Positive pressure on the diaphragm produces a positive voltage on screw terminal 2 with respect to screw terminal 3.

**Operating voltage:** Standard phantom power, 12 to 48 volts DC on screw terminals 2 and 3 with respect to screw terminal 1.

**Current drain:** 400 microamperes.

**Materials:** Steel plate and high-impact plastic capsule holder.

**Finish:** Off-white.

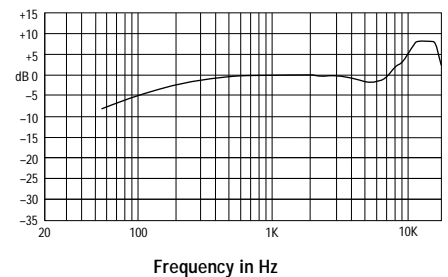
**Net weight:** 2.5 oz. (71 g).

**Dimensions:** See Fig. 2.

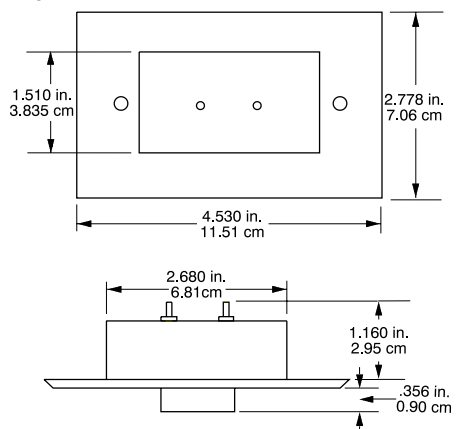
**Optional accessories:** Crown PH-1A phantom power supply (1 channel, battery or AC adapter powered), Crown PH-4B phantom power supply (4 channels, AC powered).

\*1 pascal = 10 dynes/cm<sup>2</sup> = 10 microbars = 94 dB SPL.

**Fig. 1** Frequency Response

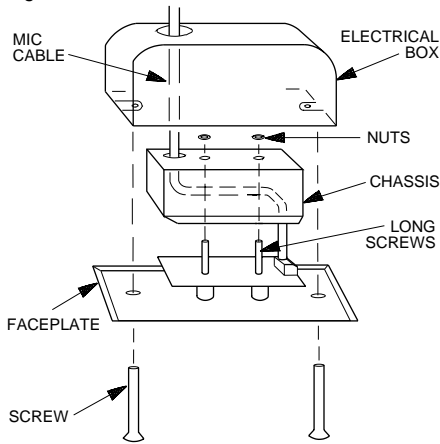


**Fig. 2**



# PZM-11

Fig. 3



7. Using the two screws provided, secure the faceplate to the electrical box.

8. If you plan to use a cable connector, solder the other end of the mic cable to a 3-pin professional audio connector (XLR-type). Solder the cable shield to pin 1, light-colored lead to pin 2, and darker lead to pin 3.

9. If you plan to use a cable connector, connect the 3-pin pro audio connector to the input of a phantom power supply. Crown makes a PH-4B phantom power supply (4 channels, AC-powered) and PH-1A phantom power supply (1 channel, battery or AC-adaptor powered).

10. Connect the output of the phantom supply to your equipment mic input. Or, if your mic input has phantom power built in, simply connect the mic cable to the mic input.

11. If the mic cable is run in metal conduit, ground loops might occur that can cause hum. If hum is present after installation, remove the ground-lift jumper (labeled GND LIFT) on the printed-circuit board.

### Architects' and Engineers' Specifications

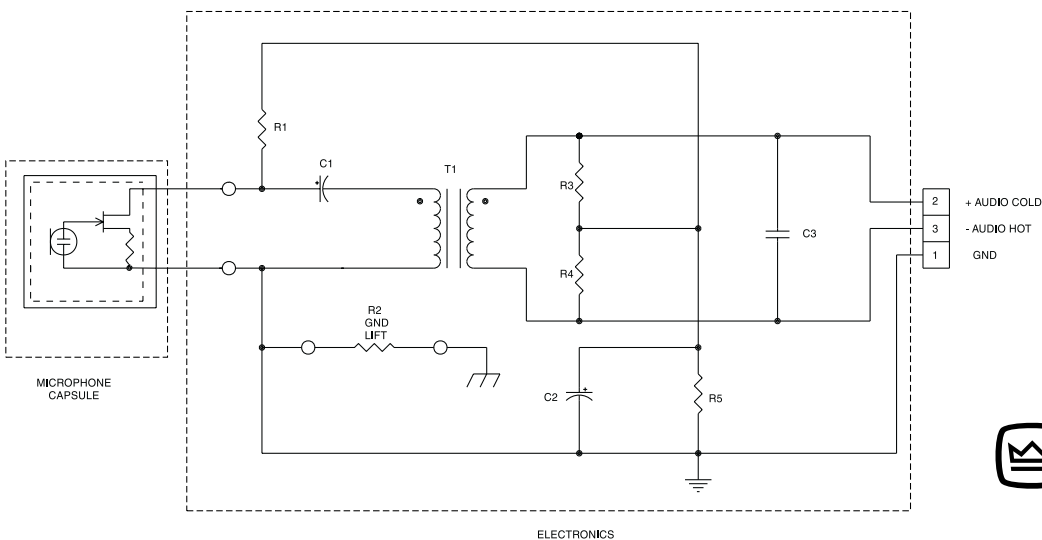
The microphone shall be the Crown Model PZM-11 or equivalent. The microphone shall be a Pressure Zone Microphone, electret-condenser type, with built-in electronics interface. The microphone capsule holder shall be mounted on a standard switch plate. The microphone shall be powered from 12-48V phantom power. The output shall be low impedance balanced. Frequency response shall be from 80 Hz to 20,000 Hz. Low frequencies below the voice range shall be rolled off. Open-circuit sensitivity shall be 5 mV/Pa (-46 dB re 1V/Pa). Maximum SPL capability shall be 120 dB SPL at 3% THD. Equivalent noise shall be 26 dBA typical (0 dB = .0002 dyne/cm<sup>2</sup>). The Crown model PZM-11 microphone is specified.

### Warranty

Crown professional microphones are guaranteed unconditionally against malfunction from any cause for a period of three years from date of original purchase. See enclosed warranty sheet for additional information.

### Service

If the unit fails to work, first replace or repair the mic cables and check the power supply. Re-check your connections to the microphone screw terminals. If service is required, return the microphone and the electronic interface in the original packaging to **Crown Service Department, Plant 2 SW, 1718 West Mishawaka Road, Elkhart, IN 46517**. For further assistance or technical support call **800-342-6939**.



PZM-11 Schematic



Crown International, Inc.  
P.O. Box 1000  
Elkhart, IN 46515-1000  
TEL: 219-294-8000  
FAX: 219-294-8FAX

©2000 Crown International, Inc.  
Specifications subject to change without prior notice. Crown® is a registered trademark of Crown International, Inc. PZM® and Pressure Zone Microphone® are registered trademarks of Crown International, Inc. Pressure Recording Process™ is a trademark of E.M. Long Associates.