

# Assembly & Care Guide For Motorized Lift Desk

MODEL: 9810501

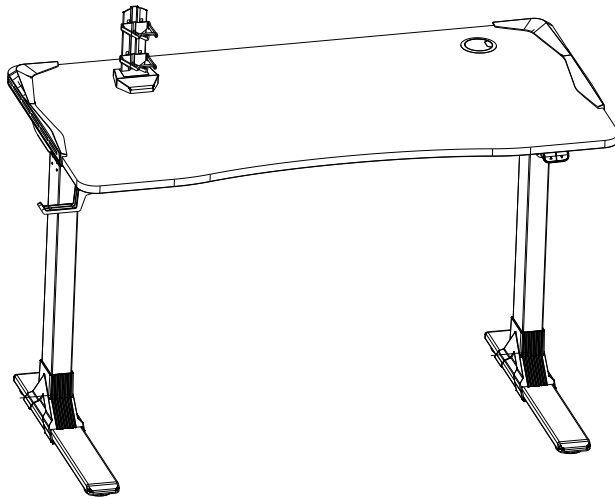

## Lift Desk Assembly Instructions

The model number of your desk is printed on the side of your carton.

Always use this number to identify your desk.

Thank you for your purchase of this quality office furniture. With proper use and care, your desk will provide you with years of use. Please follow the instructions on how to assemble and disassemble your desk. If you should have any problems with your desk DO NOT return it to the place of purchase. Please refer to the trouble shooting section of this manual or call our toll free number: **877-397-5144** and a customer service representative will assist you.

### Your Package Includes:

1 Desktop, 2 Lifting Columns, 2 Feet, 1 Handset, Accessories, & Hardware

**Please read all instructions completely** before assembling your desk.

### Technical Specifications:

Maximum Load	110lbs
Max Speed	0.98in/s
Highest Position	49in
Lowest Position	29in
Desktop Size	47"x23"x3/4"

## Table of Contents

Safety Information

Parts List and Breakdowns

Installing the Columns

Installing the Feet

Installing the Handset

Connecting the Cables & Light Strip

Installing the Accessories

Handset & Remote Operation

Trouble Shooting

Warranty

### **Safety Information**

- Power Supply: AC100V-240V, 50/60HZ.
- Check carefully to ensure correct and complete assembly before using.
- Be familiar with all functions and program settings before first use.
- Unplug the power supply before cleaning.
- Dust the surface with a dry cloth.
- Slight noise caused by the V-ribbed belt or brake system due to structure will not have any effect on the use of the equipment.
- Keep children away from motorized height adjustable desks, control units, and handsets to avoid risk of injury and electric shock.
- Keep all electrical components away from liquids.
- Do not sit or stand on the desk frame.
- Do not crawl or lie under the desk frame.
- Do not place any objects taller than 20" underneath the desk.
- Do not open any of the components; legs, control box, or switch box, to avoid the risk of injury or electric shock.
- In the event of a power outage or if the power cord is unplugged, a manual reset may be necessary. See reset procedure in troubleshooting section.
- This motorized adjustable desk has electric motors and is designed for use in dry areas only.
- The desk height is adjustable so that it can be positioned at the most ergonomically suitable height.
- Any other use is at user's risk.

## Parts List

### Tools Required:

Allen Key Wrench (Included)

### Hardware Included:

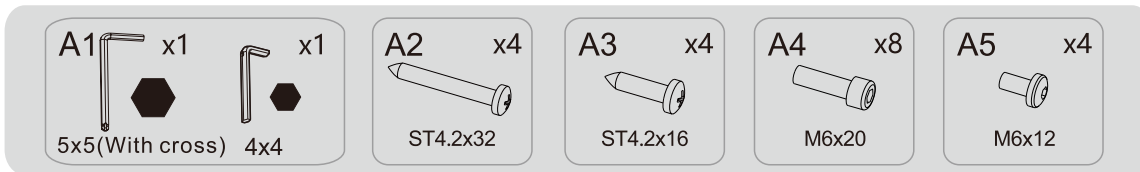

### Parts List:

Part List			Installation Instruction		
No.	Part	Qty	No.	Part	Qty
①	Tabletop set	1	②	Left lifting column set	2
③	Feet	2	④	Power plug	1
⑤	Cable Tie	4	⑥	Lifting column cover	2
⑦	Feet cover	2	⑧	Handle Rack	1
⑨	Headphone Hook	1	⑩	USB Cable Switch Rod	1
⑪	Handset	1	⑫	USB Cable	1
⑬	Remote Control	1	⑭	Handset Hook	2
⑮	Handset Support Rack	1			

## Assembly Instructions

**NOTE:** Use caution to lay out all parts on a soft surface to prevent damage to the desktop during assembly process.

### Step 1: Installing the Lifting Column

**STEP 1**      Install the lifting column

**A1** x1  
4x4

**A5** x2  
M6x12

Install the left column 1

! Rotate the column after inserting it to the bottom to avoid height difference

! Note: The method of installing the left column is the same as that of the right column, and the direction is the same.

1

Insert

1. Insert the column coupling into the gear box as shown in the figure.

2

2. Rotate the left column to the position shown in the figure to avoid the screws, and rotate it counterclockwise after fully inserting it.

3

A1  
A5  
Tighten

3. After rotating as shown in the figure, use a 4x4 allen key to tighten two M6x12 screws to complete the installation of the left column

4

4. The installation of the other side column is the same as that of the left column, and the direction is the same.

### Step 2: Installing the Feet

**STEP 2**      Install the feet

**A1** x1   **A1** x1  
5x5 (With cross) 4x4

**A2** x4  
ST4.2x32

**A4** x8  
M6x12

Install the feet

! Connect the feet to the column, use a 4x4 allen key (A1) to screw eight M6x20 (A4) and tighten them, and use a 5x5 allen key (A1) to screw ST4.2x32 self-tapping screws (A2) to fix the lifting column cover (6) and the feet cover (7).

7

3

A1  
A5  
Tighten

6

2

### Step 3: Installing the Handset

**STEP3** Install the handset

A1 x1  
5x5

Put the handset into the position shown in the figure above, align the two bottom holes of the table as shown in the figure, and not align the other bottom holes. Use a 5x5 allen key with cross (A1) to fix it with two ST4.2x19 self-tapping screws.

### Step 4: Connecting the Cables & Light Strip

**STEP4** Install the Cables and Light Strip

This adapter can be removed by tearing off stickers

A  
5:1

Put the adapter into the adapter bracket, and then connect the power cord to the adapter. One end of the switch cord is connected to the adapter, the other end is connected to the handset, and the motor line is connected to the handset. Connect the USB cables to the left and right light strips respectively, and fix them on the tabletop with cable ties.

Fix the cables to the tabletop with cable management(5x4) to keep the desk clean

1, 2, 3, 4

5

Tear off 5, Manage Cable 5, Fixed 5

## Step 5: Installing the Accessories

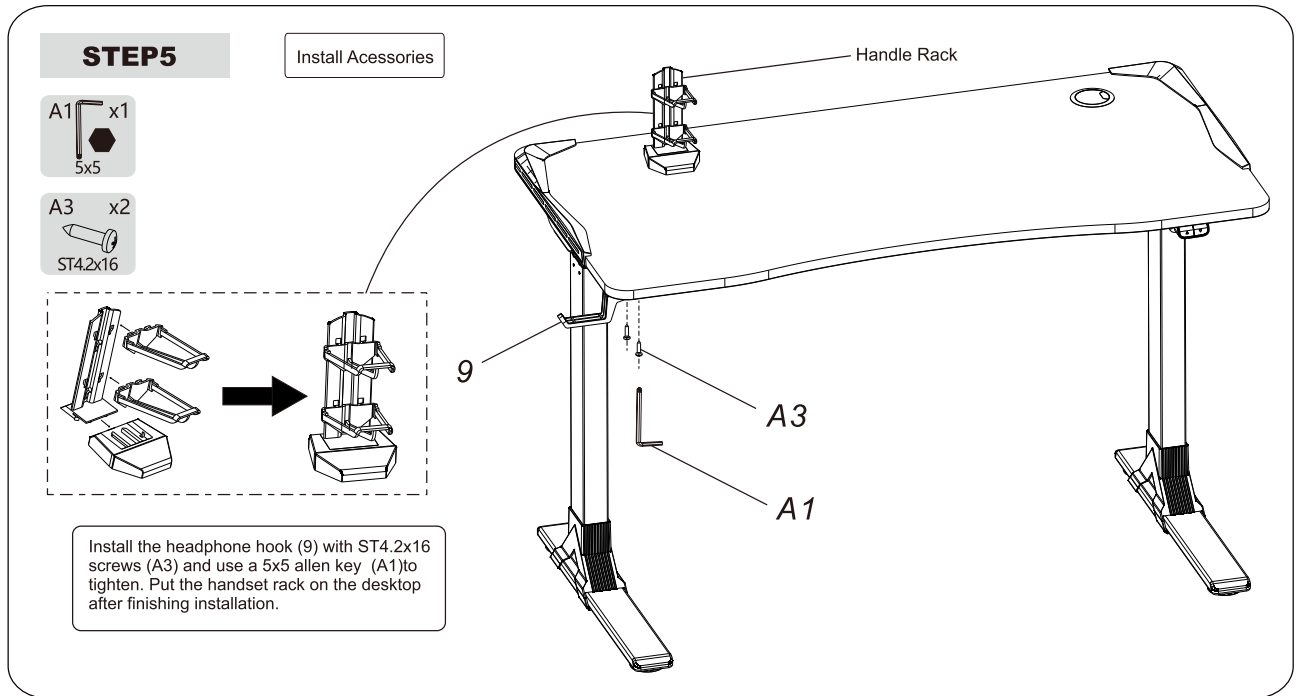

## Handset & Remote Instructions

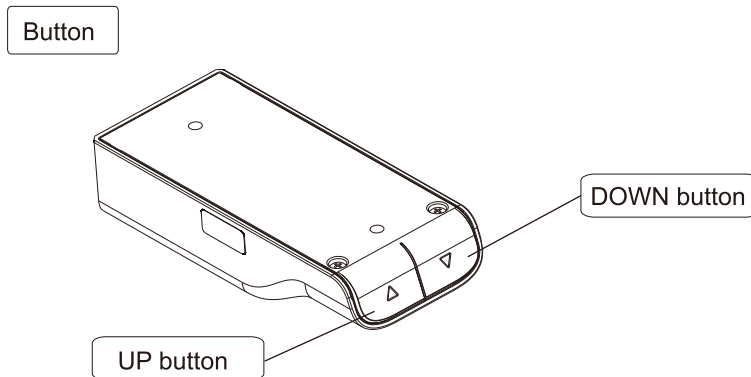

### How to use handswitch

●	“▲”	Adjust the desk upwards
●	“▼”	Adjust the desk downwards

### Instruction

- **Lifting Function**  
press the “▲” or “▼” button to increase or decrease the height
- **Reset Function**  
(1) Hold the “▼” button for more than 5 seconds to enter reset mode when at the lowest position. The reset is not completed until the lifting system reaches the bottom, then rebounds to stop.  
(2) When the lifting system fails, release the button and long press the “▼” button. The reset is not completed until the lifting system reaches the bottom, then rebounds to stop.
- **Resistance Function**  
(1) Built-in sensor, when encountering any objects, the device instantly stops and reverses to avoid damage.  
(2) Simultaneously press the “▲” and “▼” button for more than 5 seconds to turn off or turn on the resistance function.

### Remote Control

- 16 Single Colors 8 Dynamic Modes
- 18m Long Distance Control

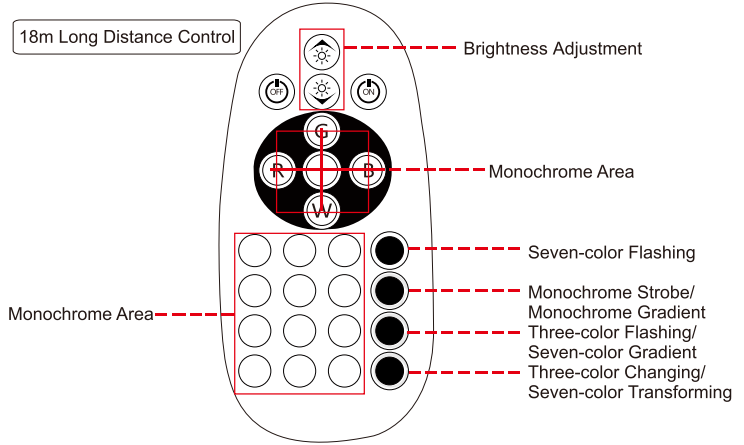

## Troubleshooting

- Desk does not adjust up or down when pressing and holding the directional arrow.
  - Check if all the cables are connected
- Desk does not rise up or rises up slowly when pressing and holding the up directional arrow.
  - Check if the load is too heavy – should not exceed 110 lbs.
- Frequent repositioning can cause desk to overwork and slow speed.
  - Discontinue power and wait 30 mins before reconnecting to power.
- If the above processes do not work, please contact customer service at 877-397-5144.



**This page left intentionally blank**

# Office Furniture Warranty

## 2-Year Limited Warranty Program

For a period of two (2) years after purchase, XLS Products, Inc. ("Manufacturer") will either repair or replace defective components in accordance with this Limited Warranty. This warranty is between Manufacturer and the original purchaser and is valid only when accompanied by the original purchaser's sales receipt showing original date of purchase and location of purchase. Replacements under this warranty revert back to the date of original purchase for future warranty.

Manufacturer or its authorized dealer can accept or reject warranty claims based on its findings. This warranty applies in normal office use only and is not intended for industrial or public use. Manufacturer can make substitutions as required of materials, components, and sub-components of comparable value and utility. This warranty is limited to product repair or replacement (to be determined solely by Manufacturer). Warranty replacement is limited to only the single affected component.

This warranty covers only manufacturing defects and does not cover normal wear and tear, abuse or misuse, exposure to extreme heat or cold, abrasion or excessive weight. This product is intended to be used in standard installations only. This warranty is invalid if the product is not used for intended purpose. Manufacturer disclaims liability for any aspect of installation and any inconvenience caused by a defective part of a component.

Certain items are not covered by this warranty. These include, but are not limited to the following:

1. Components subjected to abuse, including abuse intended to simulate failure.
2. Damages caused by retailer, shipper or installation crew (such as scratches, dents, tears, chips, etc.).
3. Any part which merely exhibits normal wear yet functions essentially as new, including chips, scratches or stretching of materials and stitching.
4. Tears, punctures, scratches or any damage caused by improper installation or use.
5. Damage to frames/welds resulting from improper assembly is not covered. General frame rusting is not covered.
6. Fading and/or discoloration of fabrics resulting from exposure to the elements, chemicals, oils, fluids or any other cause are not covered.

To make a claim, call the toll-free number below. Please have available a copy of the original sales receipt along with a brief description of the problem. Please also provide your email address and daytime telephone or cell phone #. All items may be charged actual freight costs plus \$15 for handling. Repairs or replacement will be made at the Manufacturer's option. ***Sales and use taxes, plus shipping and handling charges are the responsibility of the consumer.***

**THIS IS THE ENTIRE EXCLUSIVE EXPRESS LIMITED LIABILITY. THE MANUFACTURER NEITHER MAKES NOR IS RESPONSIBLE FOR ANY OTHER WARRANTIES, EITHER EXPRESS OR IMPLIED, INCLUDING THOSE OF RETAILING DEALERS. THIS EXCLUSIVE REMEDY IS LIMITED TO RECEIPT OF A CREDIT IN CONNECTION WITH THE REPAIR OR REPLACEMENT OF ANY PRODUCT OR COMPONENT DEEMED TO BE DEFECTIVE UNDER THE TERMS AND CONDITIONS AS STATED IN THIS WARRANTY. NEITHER XLS PRODUCTS, INC., THE PRODUCT MANUFACTURER NOR ITS AGENTS SHALL BE LIABLE IN ANY CASE FOR INCIDENTAL, INDIRECT, SPECIAL OR CONSEQUENTIAL DAMAGES RESULTING FROM THE USE OF THIS PRODUCT OR ARISING OUT OF ANY BREACH OF THIS WARRANTY OR NEGLIGENCE EVEN IF IT HAS BEEN ADVISED OF THE POSSIBILITY OF SUCH DAMAGES. EXCEPT AS OTHERWISE MAY BE REQUIRED BY LAW, THERE ARE NO OTHER EXPRESS OR IMPLIED WARRANTIES OTHER THAN THE WARRANTY DESCRIBED HEREIN, AND ALL OTHER WARRANTIES, INCLUDING ANY IMPLIED WARRANTY OF MERCHANTABILITY OR FITNESS FOR A PARTICULAR PURPOSE ARE EXPRESSLY DISCLAIMED.**

**Contact Warranty Services at:      [ContactUs@Hanover-Products.com](mailto:ContactUs@Hanover-Products.com)  
**1-877-397-5144****