

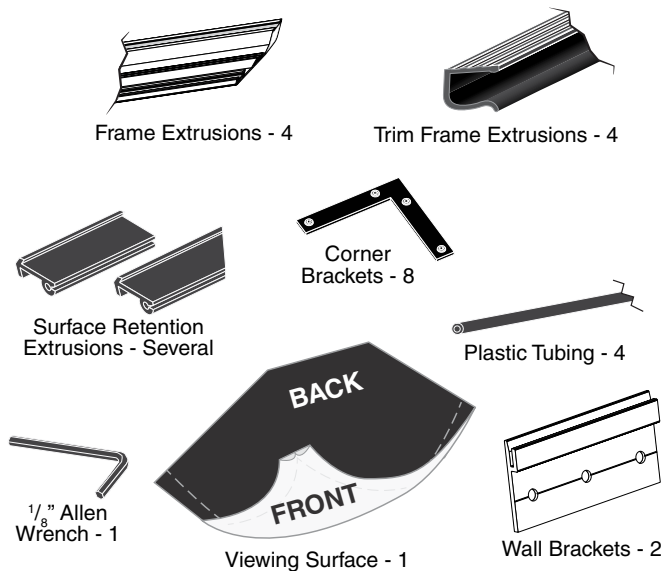
# Assembly Instructions

## Profile Permanently Tensioned Projection Screen by Draper

### ⚠ Caution

- ① Read instructions through completely before proceeding.
  - ② **Follow instructions carefully.**  
Installation contrary to instructions invalidates warranty.
  - ③ Screen should be accessible for complete removal should fabric become damaged or should other service be required.
  - ④ Screen should be installed level (using a carpenter's level).
  - ⑤ Nothing should be fastened to screen frame or viewing surface.
  - ⑥ Make sure you have received all parts (see parts list below and exploded diagram on page 3).
  - ⑦ **Tools Required:** 1/8" Allen wrench (included); #2 Phillips screwdriver.  
**Optional tools:** Flat blade screwdriver or small putty knife.
  - ⑧ Installer is responsible for providing appropriate hardware for mounting.
  - ⑨ **Draper recommends using two people for assembly and installation.**  
When lifting assembled screen, do not lift at only one corner; lift at both corners. Lifting by one corner could result in damage to the screen frame, especially on large screens.
  - ⑩ The ideal temperature range for assembling permanently tensioned screens to prevent damaging the surface is **68°-78° F (20°-26° C)**.  
Assembling below recommended temperatures may damage surface and void warranty.
- NOTE:** Screen has been thoroughly inspected and tested at factory and found to be operating properly prior to shipment.

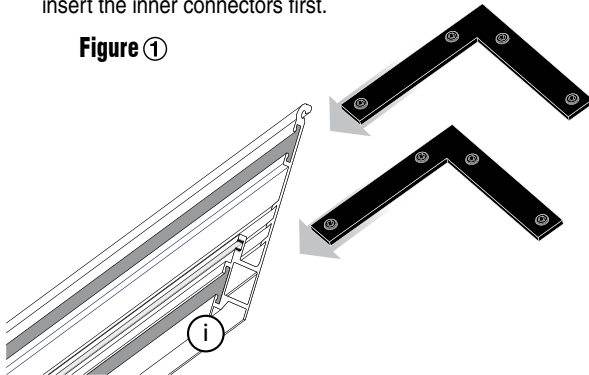
### Hardware and Parts List



### Frame Preparation

- ① Clean area and place frame assembly pieces face down. Insert corner brackets into the first (i) aluminum frame extrusions. For easier assembly insert the inner connectors first.

**Figure ①**



Patented by Draper, Inc., U.S. Patent Nos. 6,785,047; 7,113,332; and 7,369,310.

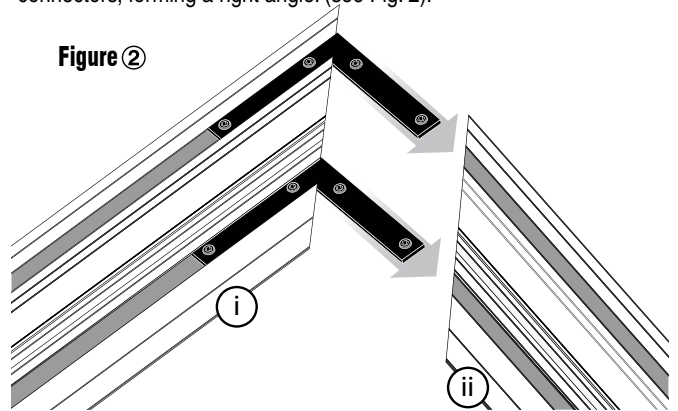
# DRAPER

411 S. Pearl St., Spiceland, IN 47385 USA ■ 765-987-7999  
www.draperinc.com ■ fax 765-987-7142

Copyright © 2016 Draper Inc. Form Profile\_Inst16 Printed in U.S.A.

- ② Slide second (ii) aluminum frame extrusion over exposed portion of inner connectors, forming a right angle. (see Fig. 2).

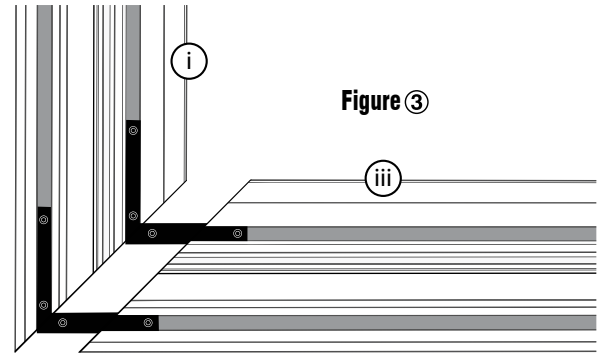
**Figure ②**



**Please Note:** If corner brackets do not slide into frame extrusions, make sure that setscrews are backed out enough to allow proper clearance.

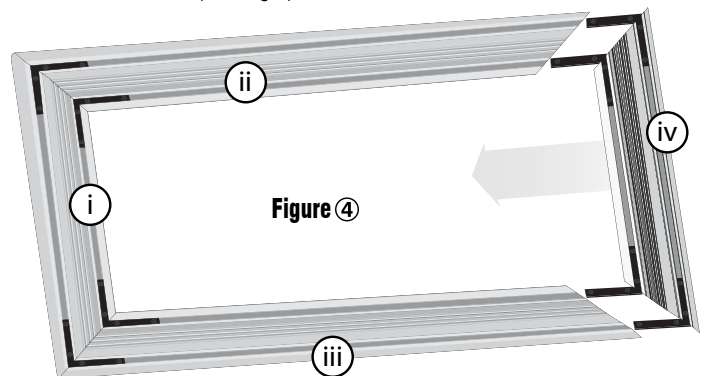
- ③ Repeat on the opposite end of the first extrusion (i) and slide the third (iii) frame extrusion into place (see Fig. 3).

**Figure ③**



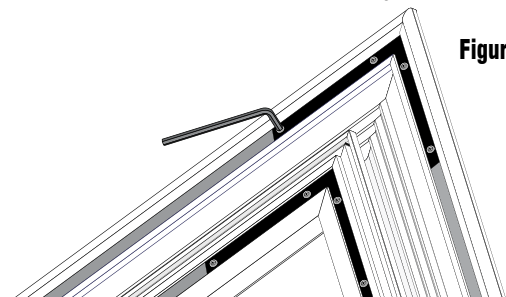
- ④ Next, insert the remaining corner brackets into the fourth (iv) frame extrusion. Then slide the brackets and extrusion into the three assembled frame extrusions (see Fig 4).

**Figure ④**



- ⑤ When all four corners are secure, tighten the setscrews on corner brackets with provided Allen wrench (see Fig. 5).

**Figure ⑤**



**(Continued on Page 2)**

If you encounter any difficulties installing or servicing your Profile screen, call your dealer or Draper, Inc., Spiceland, Indiana, (765) 987-7999.

**Surface Preparation**

⑥ Move assembled frame out of the way. Unroll the viewing surface with the provided foam packing material. Lay them together on a smooth/clean surface with the folded side of the hem visible (back side up).

⑦ Insert plastic tubing inside pocket formed by hem on all 4 edges of viewing surface (see Fig. 7).

Insert Plastic Tubing into Hem Pocket

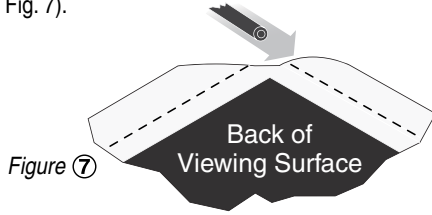


Figure ⑦

⑧ **Carefully** slide surface retention extrusions (flat edge visible) along hem and onto surface on all 4 edges of fabric (see Fig. 8).

Slide Surface Retention Extrusion Over Plastic Tubing

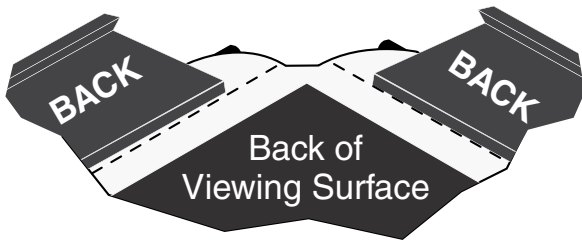


**Caution:** Do not allow fabric to snag on end of extrusion. If the screen fabric is not parallel with the surface retention extrusion, then it may slit and tear during installation.

**Please Note:** To make this step easier, pinch the end of the pocket closed before sliding it into the surface retention extrusion.

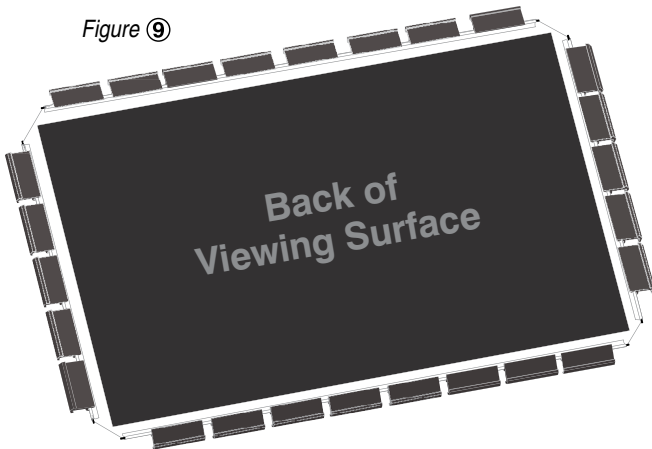


Figure ⑧



⑨ Verify that all surface retention extrusions are installed with flat edge visible and are evenly spaced on surface material (see Fig. 9).

Figure ⑨

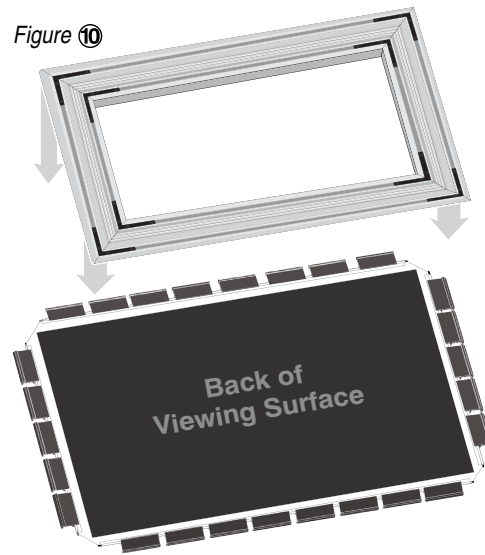


**⚠ Caution:** Draper strongly recommends using the provided foam packing material as a protective barrier between the viewing surface and the work area. This will help to ensure that the viewing surface is not damaged during the assembly process.

**Surface to Frame Assembly**

⑩ Place frame face down, in the center of the viewing surface (see Fig. 10).

Figure ⑩



⑪ Beginning in a corner, grab surface retention extrusion and wrap fabric around the frame. Pull fabric towards the center of the frame and hook into notch #1 on corresponding side of frame extrusion (see Fig. 11).

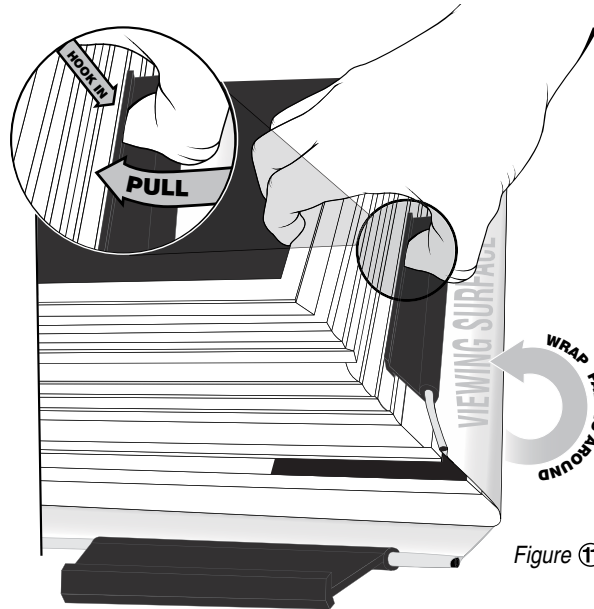


Figure ⑪

⑫ Insert opposite side of surface to notch #1 of frame extrusion.

⑬ Repeat steps 11-12 with remaining edges of surface.

⑭ Ensure surface retention extrusions are evenly spaced in tension slots on all 4 edges of surface, resulting in a flat viewing surface (see Fig. 14). If additional tension is desired or required over time, adjust surface one edge at a time to tension notch #2.

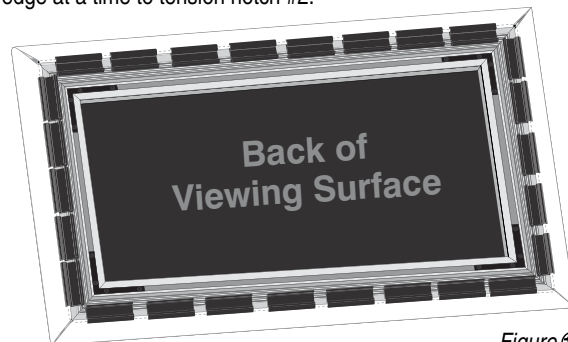
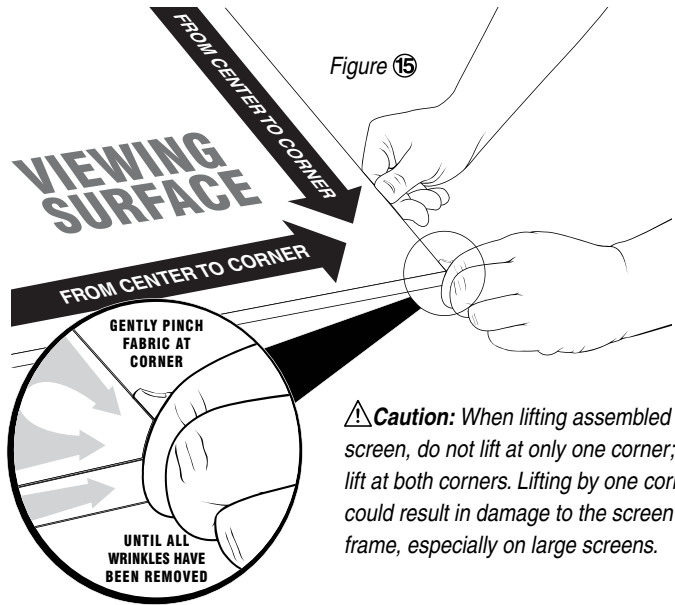


Figure ⑭

**Please Note:** It is not necessary to adjust more than one edge at a time to increase surface tension.

**Smoothing Viewing Service**

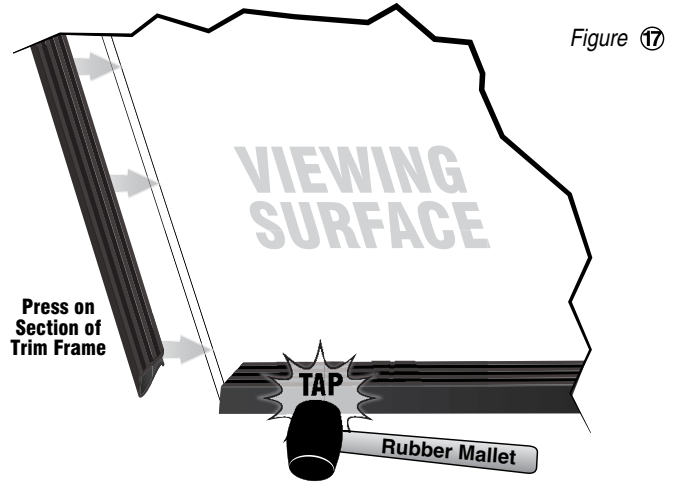
- 15 Turn over entire screen and inspect the viewing surface for wrinkles. If wrinkles are present, massage the fabric from the middle of the frame to the corners. Using your thumb and forefinger, gently pinch fabric at the corners until all wrinkles have been removed (see Fig. 15).



**Caution:** When lifting assembled screen, do not lift at only one corner; lift at both corners. Lifting by one corner could result in damage to the screen frame, especially on large screens.

**Attaching Trim Frame**

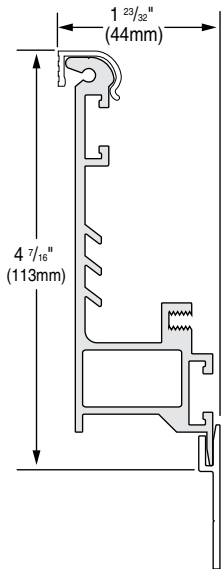
- 16 Once viewing surface is completely flat, carefully trim the excess fabric from the corners, taking care not to wrinkle or damage the fabric.
- 17 Carefully place trim frame extrusion over Profile frame, taking care not to damage viewing surface (see Fig. 17). Gently tap into place using a rubber mallet.



- 18 Repeat on the 3 remaining sides. Make sure mitered edges of extrusions line up properly in all 4 corners.
- 19 The Profile Permanently Tensioned Projection Screen by Draper is now completely assembled.

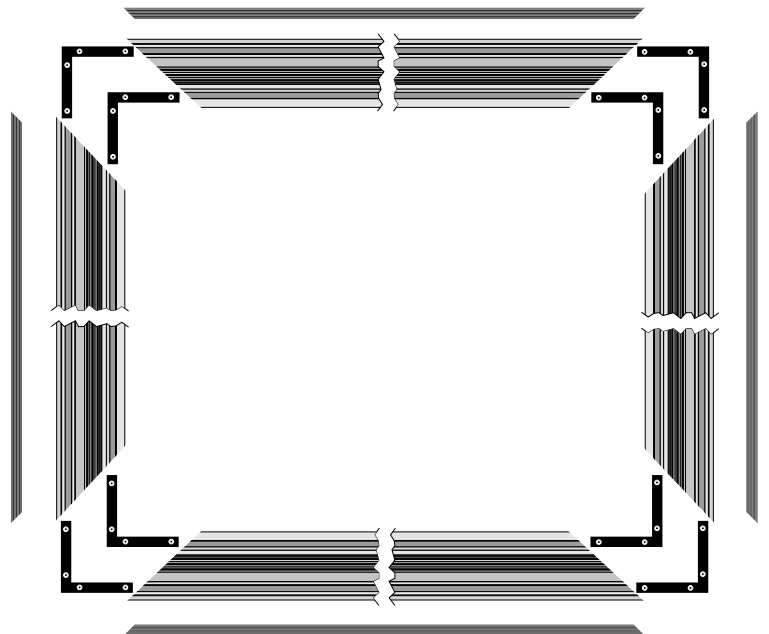


**Profile Frame —Side Detail\***



\*Viewing surface is approx. 1 5/8" (41mm) from wall.  
Minimum distance between top edge of Wall Mount Bracket and ceiling is 5" (127mm).

**Profile Frame (Exploded View)**



The Profile has a precision-cut mitered-corner trim frame.  
**Please Note:** DO NOT LIFT PRODUCT BY TRIM FRAME. The entire assembled screen should be lifted from the bottom, and the sides supported during mounting and maintenance.