

DA-LITE[®]
A brand of  **legrand**



Advantage[®] Series

USER MANUAL

200081 Rev D

TABLE OF CONTENTS

Advantage® (With Closure Door)
Previously Named: Tensioned Advantage Deluxe Electrol

13

Advantage
Previously Named: Tensioned Advantage Electrol

26

Advantage with SightLine

39

Advantage (Over 14' W with Closure Door)
Previously Named: Tensioned Large Advantage Deluxe Electrol

51

Advantage (Over 16' W)
Previously Named: Tensioned Large Advantage Electrol

DA-LITE
A brand of  **legrand**



Advantage[®]

(with Closure Door)

USER MANUAL

200078 Rev C

ORIGINAL INSTRUCTIONS

DISCLAIMER

Legrand AV Inc. and its affiliated companies and subsidiaries (collectively, "Legrand AV"), intend to make this manual accurate and complete. However, Legrand AV makes no claim that the information contained herein covers all details, conditions or variations, nor does it provide for every possible contingency in connection with the installation or use of the products described herein. The content herein is subject to change without notice or obligation of any kind. To the maximum extent permitted by applicable law, Legrand AV makes no representation or warranty, expressed or implied, regarding the information contained herein. Furthermore, Legrand AV assumes no responsibility for accuracy, completeness or sufficiency of the information contained in this document.

Da-Lite® is a registered trademark of Legrand AV. All rights reserved.

IMPORTANT SAFETY INSTRUCTIONS

When using your video equipment, basic safety precautions should always be followed, including the following:

1. Read and understand all instructions before using.
2. Position the cord so that it will not be tripped over, pulled, or contact hot surfaces.
3. If an extension cord is necessary, a cord with a current rating at least equal to that of the appliance should be used. Cords rated for less amperage than the appliance may overheat.
4. To reduce the risk of electric shock, do not disassemble this appliance. Contact an authorized service dealer when repair work is required. Incorrect reassembly can cause electric shock when the appliance is used subsequently.
5. The use of an accessory attachment not recommended by the manufacturer may cause a risk of fire, electric shock, or injury to persons.
6. Failure to provide adequate structural strength for this component can result in serious personal injury or damage to equipment! It is the installer's responsibility to make sure the structure to which this component is attached can support the weight of all equipment. Reinforce the structure as required before installing the component.
7. Use this projection screen only for its intended use as described in these instructions. Do not use attachments not recommended by the manufacturer.

Save These Instructions

PRE-INSTALLATION

1. Carefully unpack screen and remove outer wrapping from case.
2. Make sure to recheck measurements of screen location before installation.

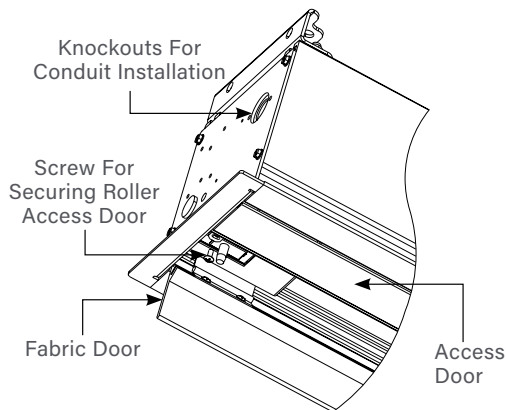

Figure 1

CASE INSTALLATION

1. The case provides multiple attachment points for bolts, cables, or threaded rod. See Suggested Methods of Installation. The variable position-mounting bracket may be located anywhere along the length of the case. It is recommended to keep the brackets spaced evenly enough to distribute the weight of the screen.

The case has a self-trimming flange around the bottom. Ceiling tiles or drywall may be placed on top of this flange to provide a finished appearance.

2. After securing the case in the ceiling check that the case is level and plumb.

NOTE: For proper operation, case must be levelled side to side and front to back.

3. Install electrical connections that apply to your unit. Refer to the following diagrams for proper installation. The terminal block for the wall switch connections is located under the metal housing surrounding the junction box. Remove two screws for access.

NOTE: Use provided knockouts for all electrical connections. DO NOT drill additional holes into screen case or end cap.

SCREEN AND ROLLER ASSEMBLY INSTALLATION

If your screen was shipped with the motor and roller already installed proceed to step 6.

1. Remove the screw from each end of the access door (front door) and open the door. See figure 1.
2. Carefully unpack screen and roller assembly. Leave packing paper on the roller.
3. Place the roller assembly into the case with the motor on the left side. The limit switches should be facing down. Line up the square pin on the motor with the square hole in the bracket and secure with the cotter pin. See figure 2.
4. Lift the pin end (right end) of the roller into position and slide the bracket onto the roller pin and secure with the cotter pin. Tighten two nuts to secure the bracket. See figure 3.
5. Complete electrical hook-up by snapping motor wire connector into case connector.

⚠ CAUTION! Do not cut tape on fabric with a knife or any sharp tool. Remove by hand.

⚠ ATTENTION! Ne coupez pas le ruban adhésif sur la toile avec un couteau ou un outil tranchant. Retirez à la main.

6. Carefully remove tape strips securing picture surface around roller. Slat should move freely (Fig. 2). (Only if the roller assembly is preinstalled.)
 7. Test installation by operating the screen several times. Be prepared to stop the screen. Standard Duty Cycle: 1 MIN. ON/3 MIN. OFF. The fabric door (rear door) will not close until the wall switch is placed in the up position and when the screen motor stops at its limit switch in the up direction.
- NOTE:** Excessive continuous operation may cause the motor to overheat. If this happens the motor will shut off until it cools to a normal operating temperature.
8. Remove any shipping foam attached to the inside of the access and fabric doors before operation.
 9. Run the screen down enough to open the fabric door. Close the access door and reinstall the screws to secure the door.

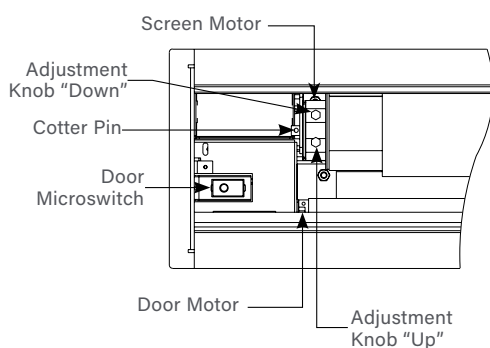

Figure 2

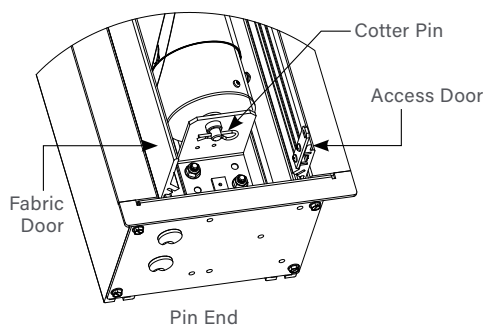

Figure 3

SCREEN ADJUSTMENT

NOTE: Use a screw driver or 5/32" Allen wrench to make adjustments.

More Screen Drop

1. Place operating switch in "down" position.
2. When the screen stops, turn the "down" limit knob (Fig. 2) one-quarter turn counterclockwise. Test by raising picture surface approximately two feet, then lower again. Repeat until desired picture surface position is attained.

⚠ CAUTION: Do not adjust for more drop than what was ordered. At least 1-1/2 wraps of fabric must remain on the roller. This screen comes standard with 0" or 2" black at the top. See the specification data sheet for details.

⚠ ATTENTION! N'effectuez pas de réglage pour obtenir un déroulement supérieur à celui commandé. Au moins 1 à 1/2 tour de toile doit être maintenu sur le cylindre. Cet écran est doté de série d'une bande noire supérieure de 0 cm (0 po) ou 5 cm (2 po). Consultez la fiche technique pour plus de renseignements.

Less Screen Drop

1. Raise picture surface approximately two feet above desired level.
2. Place operating switch in "off" position.
3. Turn the "down" limit switch (Fig. 2) one-quarter turn clockwise. Test by raising picture surface approximately two feet, then lower again. Repeat until desired picture surface position is attained.

Contact Da-Lite at 800-622-3737 if door motor needs adjustment.

**ADVANTAGE (WITH CLOSURE DOOR)
SUGGESTED METHODS OF INSTALLATION**

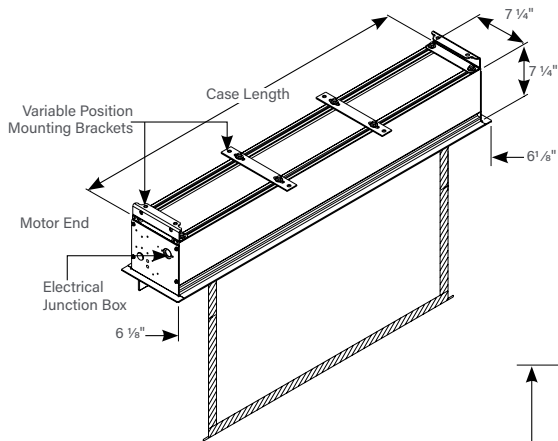

Flat Bar Mounting Method

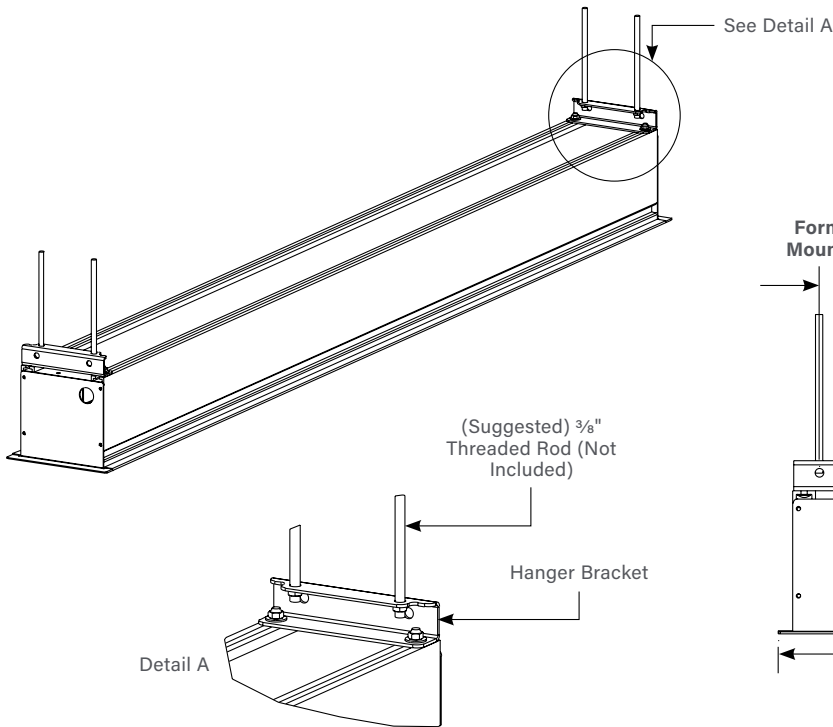
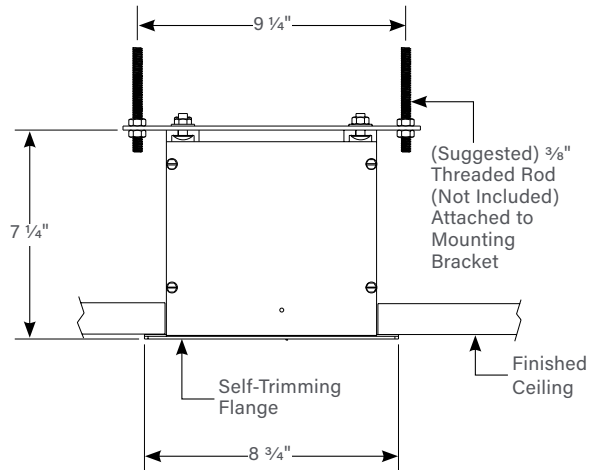

Formed Bracket Mounting Method

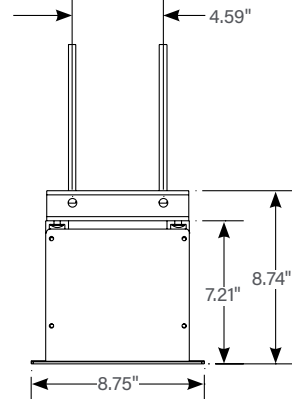

ADVANTAGE (WITH CLOSURE DOOR) INSTRUCTIONS FOR STANDARD CONTROL

120V Wiring Diagram

NOTE: Electrical connections on left end of case.

Use provided knockouts for all electrical connections. DO NOT drill additional holes into screen case or end cap.

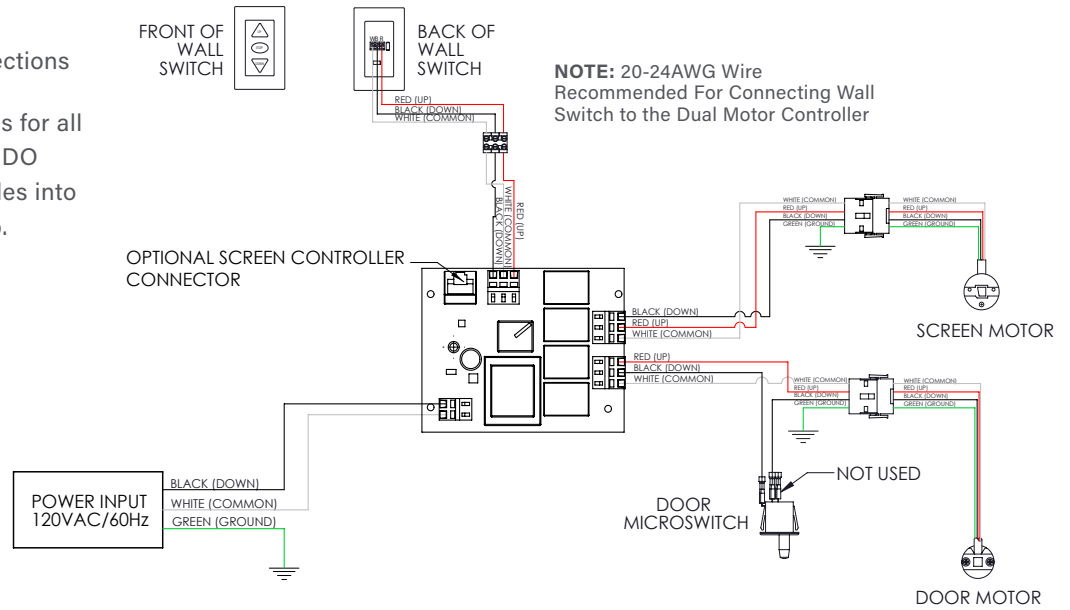

230V Wiring Diagram

NOTE: Electrical connections on left end of case.

Use provided knockouts for all electrical connections. DO NOT drill additional holes into screen case or end cap.

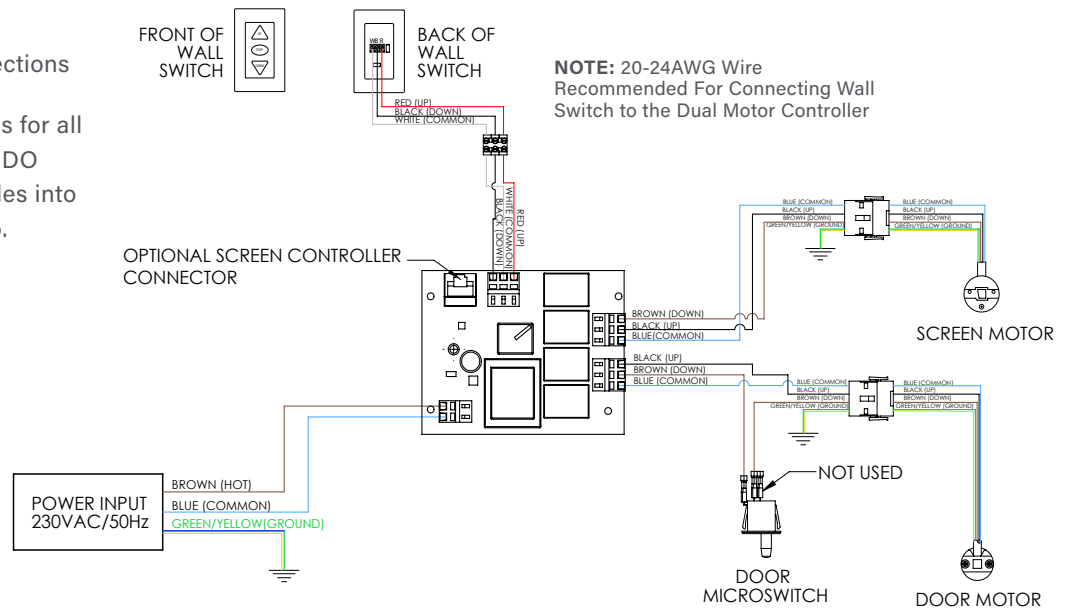

TROUBLESHOOTING

SYMPTOM	CAUSE	SOLUTION
Screen will not operate or will not go "down." Motor does not hum.	Incorrect line voltage.	Verify 115-125V (or 220-240V). If insufficient voltage, rewire incoming electric line.
	Blown facility fuse.	Replace facility fuse.
	Tripped facility circuit breaker.	Reset facility circuit breaker.
	No power to operating switch or junction box.	Check above. Tighten all loose wire connections. Recheck wiring. See installation instructions. "Down" Position Check for power across black and white leads.
	Power at junction box. Thermal overload tripped.	Let motor cool down for 15 minutes. Try again.
	Broken wire in the "down" position.	Check for continuity.
	Defective motor, limit switch or capacitor.	Replace motor assembly. NOTE: Motor is a sealed assembly.
	Capacitor burned out.	Replace motor assembly.
Screen will not move upward. Motor does not hum.	Incorrect line voltage.	Verify 115-125V (or 220-240V). If insufficient voltage, rewire incoming electric line.
	Blown facility fuse.	Replace facility fuse.
	Tripped facility circuit breaker.	Reset facility circuit breaker.
	No power to operating switch or junction box.	Check above. Tighten all loose wire connections. See above. "Up" Position Check for power across red and white leads..
	Open door limit switch.	Replace switch.
	Power at junction box. Thermal overload tripped.	Let motor cool down for 15 minutes. Try again.
	Broken wire in the "up" position.	Check for continuity.
	Defective motor, limit switch or capacitor.	Replace motor assembly. NOTE: Motor is a sealed assembly.
	Capacitor burned out.	Replace motor assembly.
Motor hums.		

TROUBLESHOOTING (CONT.)

SYMPTOM	CAUSE	SOLUTION
Door will not open.	Hinge is bound or has a foreign substance on it which does not allow it to open by gravity.	Check installation to free door. Clear any foreign substance; i.e., paint or plaster from hinge.
	No power.	See above.
Door does not close.	Open door limit switch.	Replace switch.
	No power from screen motor.	Replace screen motor.
"Down" limit switch incorrect.	"Down" limit switch out of adjustment.	See installation instructions.
Noise. NOTE: Screen will operate with a low-pitched hum.	Buzzing noise.	Adjust door limit switch (too far down).
	Gear noise.	Replace motor assembly.
Coasting.	Defective brake.	Replace motor assembly.
Roller displaced from mounting bracket.	Pin end slipped out of nylon bearing.	Realign pin end bracket.
Fabric hangs crooked.	Screen not installed properly.	Check for level and plumb.
	Fabric is damaged.	Replace fabric.
Door closes before screen is all the way up.	Screen "up" limit out of adjustment.	Adjust "up" limit (call factory for instructions).
Door opens but screen does not operate.	Loose wire.	Check all wiring and connections.

CONDITIONS FOR TRANSPORTATION AND STORAGE

- Temperature: Between 40 - 100°F (5 - 40°C)
- Relative Humidity: 30% to 70%, non-condensing
- Always keep the projection screen horizontal during transport and storage
- Make sure the entire package is supported when stored
- Do not stack more than six projection screens on top of each other
- Make sure the heaviest package is placed at the bottom of the stack

Screen surface should be allowed to air out once every two months, or otherwise used on a regular basis, if the temperature is above 72°F (22°C) and at least once every month if the temperature goes above 85°F (30°C).

LIMITED FIVE-YEAR WARRANTY ON DA-LITE PRESENTATION PRODUCTS

Legrand AV Inc. warrants certain Da-Lite branded products to the original purchaser only, to be free from defects in materials and workmanship for a period of five (5) years from the date of purchase by the original purchaser; provided they are properly operated according to Da-Lite's instructions and are not damaged due to improper handling or treatment after shipment from the factory.

Limited five-year warranty applies to the following products:

Wireline Advantage®, Tensioned Advantage Series, Advantage Series, Tensioned Professional, Professional, Tensioned Contour®, Contour, Tensioned Cosmopolitan® Series, Cosmopolitan Series, Tensioned Designer Contour, Designer Contour, Studio, Arena, Parallax®, Parallax Thin, FullVision, UTB Contour, Cinema Contour, Da-Snap, IDEA™ Screen, IDEA Panoramic, Fast-Fold® Deluxe, Fast-Fold Deluxe Drapery Kits, Da-Plex, and Rear Projection Mirror System.

This warranty does not apply to equipment showing evidence of misuse, abuse or accidental damage, or which has been tampered with or repaired by a person other than authorized Da-Lite personnel.

Da-Lite's sole obligation under this warranty shall be to repair or to replace (at Da-Lite's option) the defective part of the merchandise. Returns for service should be made to your Da-Lite dealer. If it is necessary for the dealer to return the screen or part to Da-Lite, transportation expenses to and from Da-Lite are payable by the purchaser and Da-Lite is not responsible for damage in shipment. To protect yourself against damage or loss in transit, insure the product and prepay all transportation expenses.

TO THE MAXIMUM EXTENT PERMITTED BY APPLICABLE LAW, THIS WARRANTY IS IN LIEU OF ALL OTHER WARRANTIES, EXPRESS OR IMPLIED, INCLUDING WARRANTIES AS TO FITNESS FOR USE AND MERCHANTABILITY. Any implied warranties of fitness for use, or merchantability, that may be mandated by statute or rule of law are limited to the five (5) year warranty period. This warranty gives you specific legal rights, and you may also have other rights, which vary from state-to-state. **TO THE MAXIMUM EXTENT PERMITTED BY APPLICABLE LAW, NO LIABILITY IS ASSUMED FOR EXPENSES OR DAMAGES RESULTING FROM INTERRUPTION IN OPERATION OF EQUIPMENT, OR FOR INCIDENTAL, DIRECT, OR CONSEQUENTIAL DAMAGES OF ANY NATURE.**

In the event that there is a defect in materials or workmanship of a Da-Lite product, you may contact Customer Care at 3100 North Detroit Street, Warsaw, IN 46582, (866) 977-3901.

IMPORTANT: THIS WARRANTY SHALL NOT BE VALID AND DA-LITE BRANDED PRODUCTS SHALL NOT BE BOUND BY THIS WARRANTY IF THE PRODUCT IS NOT OPERATED IN ACCORDANCE WITH THE DA-LITE WRITTEN INSTRUCTIONS.

Keep your sales receipt to prove the date of purchase and your original ownership.

DA-LITE
A brand of **legrand**



Advantage[®]

USER MANUAL

200157 Rev D

ORIGINAL INSTRUCTIONS

DISCLAIMER

Legrand AV Inc. and its affiliated companies and subsidiaries (collectively, "Legrand AV"), intend to make this manual accurate and complete. However, Legrand AV makes no claim that the information contained herein covers all details, conditions or variations, nor does it provide for every possible contingency in connection with the installation or use of the products described herein. The content herein is subject to change without notice or obligation of any kind. To the maximum extent permitted by applicable law, Legrand AV makes no representation or warranty, expressed or implied, regarding the information contained herein. Furthermore, Legrand AV assumes no responsibility for accuracy, completeness or sufficiency of the information contained in this document.

Da-Lite® is a registered trademark of Legrand AV. All rights reserved.

IMPORTANT SAFETY INSTRUCTIONS

When using your video equipment, basic safety precautions should always be followed, including the following:

1. Read and understand all instructions before using.
2. Maximum surrounding air temperature 122°F (50°C).
3. Main disconnect must be incorporated in the fixed wiring in accordance with the wiring rules.
4. Rated for indoor use only.
5. Use copper rated conductors rated 167°F (75°C) or higher.
6. If the supply cord is damaged, it must be replaced by the manufacturer, its service agent or similarly qualified persons in order to avoid hazard.
7. Supplied drive is only intended for use in Da-Lite screen models Advantage, Contour, and Cosmopolitan.
8. Position the cord so that it will not be tripped over, pulled, or contact hot surfaces.
9. If an extension cord is necessary, a cord with a current rating at least equal to that of the appliance should be used. Cords rated for less amperage than the appliance may overheat.
10. To reduce the risk of electric shock, do not disassemble this appliance. Contact an authorized service dealer when repair work is required. Incorrect reassembly can cause electric shock when the appliance is used subsequently.
11. The use of an accessory attachment not recommended by the manufacturer may cause a risk of fire, electric shock, or injury to persons.
12. Failure to provide adequate structural strength for this component can result in serious personal injury or damage to equipment! It is the installer's responsibility to make sure the structure to which this component is attached can support the weight of all equipment. Reinforce the structure as required before installing the component.
13. Use this projection screen only for its intended use as described in these instructions. Do not use attachments not recommended by the manufacturer.

Save These Instructions

ADVANTAGE SUGGESTED METHODS OF INSTALLATION

Method 1

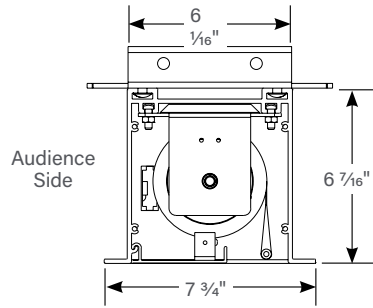
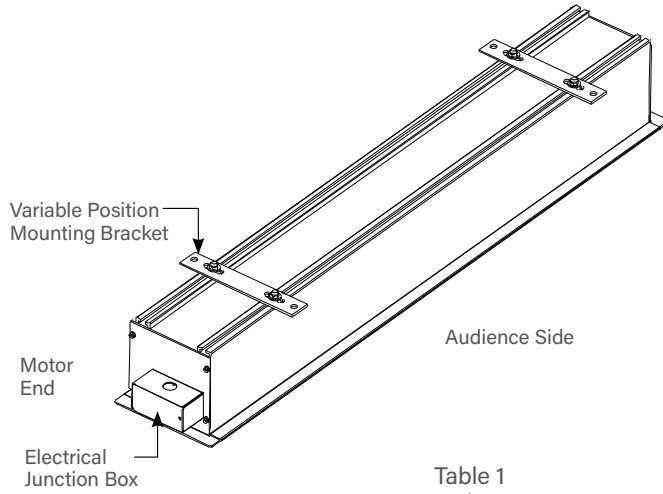
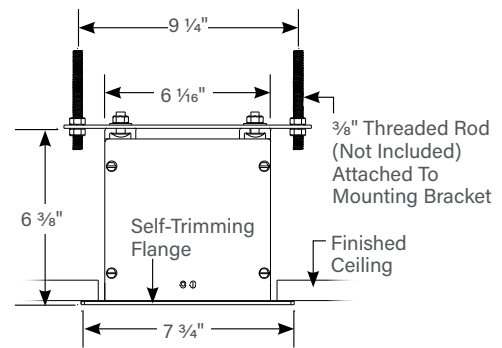

Table 1

Case Length	Number of Mounting Brackets
97.25" and Under	2
Over 97.25" to 182"	3
Over 182" to 212.75"	4



Method 2

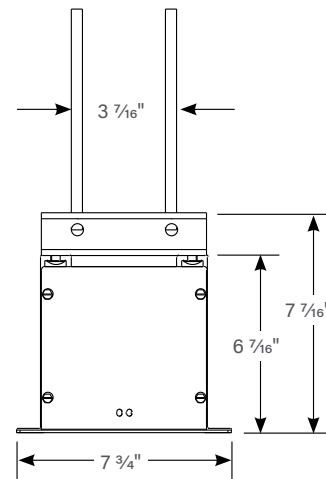
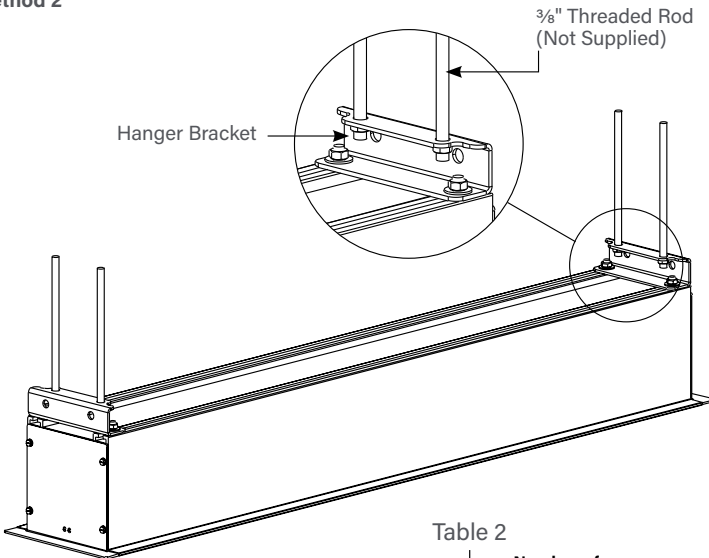
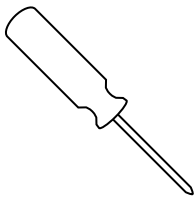

Table 2

Case Length	Number of Mounting Brackets
182" and Under	2
Over 182" to 212.75"	3

TOOLS REQUIRED FOR INSTALLATION



#2 Phillips
Screwdriver

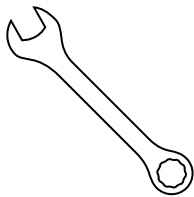

1/2" Open Wrench
or Socket Driver

PRE-INSTALLATION

1. Carefully unpack case from shipping carton.
2. Set aside the Installation Kit. Items inside will be used during installation.
3. Make sure to recheck measurement of case for proper installation clearance.
4. Remove any protective foam covering the outside of the case.
5. For shipping purposes, foam is also inserted between the roller brackets and end caps (Figure 1). Remove these foam blocks from the ends.
6. Remove the hanger brackets from the top of the case using a 1/2" wrench. Do not discard the hardware; it will be used during case installation to re-attach the hanger brackets for mounting.

CASE INSTALLATION

1. Hang case and attach to support structure with bolts.
See Suggested Methods of Installation.
2. Tighten bolts until trim flange is flush with ceiling.
NOTE: For proper operation, case must be levelled side to side and front to back.
3. Remove 2 screws to open junction box. Install electrical connections that apply to your unit. Make sure to review the wiring diagram for proper hook up. Replace junction box cover and secure with 2 screws.

NOTE: Must be installed in accordance with the requirements of the Local Building Codes, the Canadian Electrical Code (CEC), CAN/CSA C22.1 and the National Electric Code (NEC), NFPA 70.

If your case was ordered in advance of the screen and roller assembly, your installation is now complete. Continue to step 4 if your Advantage was ordered as a complete unit.

4. Carefully remove paper and tape from roller assembly. DO NOT use a knife or sharp object to cut tape; you will damage the screen. Pull orange string..
5. Test installation by running screen up and down a few times.
Be prepared to stop screen should any objects obstruct the movement of the screen. To prevent damage to the motor, the standard duty cycle is 1 minute on and 3 minutes off.

SCREEN AND ROLLER ASSEMBLY INSTALLATION

Follow these steps if your screen and roller assembly was ordered separately from the case.

1. Remove the access door. First, remove the 2 screws from the ends. Be sure to support the door during this step to avoid injury. Then lift the door slightly and pull away from the edge of the case (Figure 1).
2. Carefully unpack screen and roller assembly. Leave packing paper on roller.
3. To install screen and roller assembly, loosen (but do not remove) four 1/4-20 nuts securing pin end bracket (opposite end from the junction box) to the case housing. Slide the pin end bracket towards the end of the case (Figure 2).
4. Insert the motor end square shaft into the motor end bracket (junction box end) and secure with the cotter pin. (Figure 2).
5. Moving to the pin end of the case, slide the pin end bracket until the hole fits securely over the pin and secure with the cotter pin. Tighten the 1/4-20 nuts on the pin end bracket securely (Figure 2).
6. Complete electrical hook-up by snapping motor wire connector into case connector (Figure 2).
7. Carefully remove paper and tape from roller assembly. **DO NOT** use a knife or sharp object to cut tape; you will damage the screen. Pull orange string.
8. Test installation by running screen up and down a few times. Be prepared to stop screen should any objects obstruct the movement of the screen. To prevent damage to the motor, the standard duty cycle is 1 minute on and 3 minutes off.
9. Re-install the access door. Procedure is the reverse of step 1 listed above.

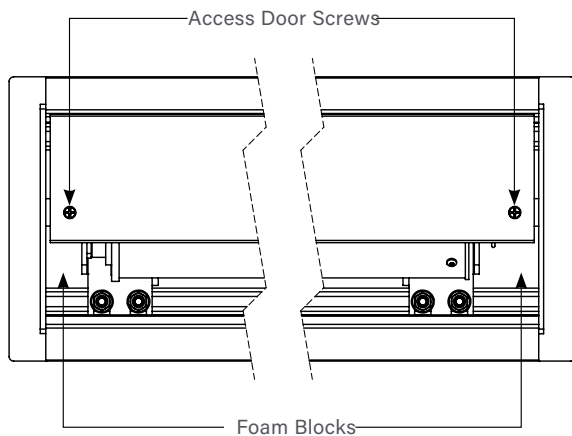

Figure 1

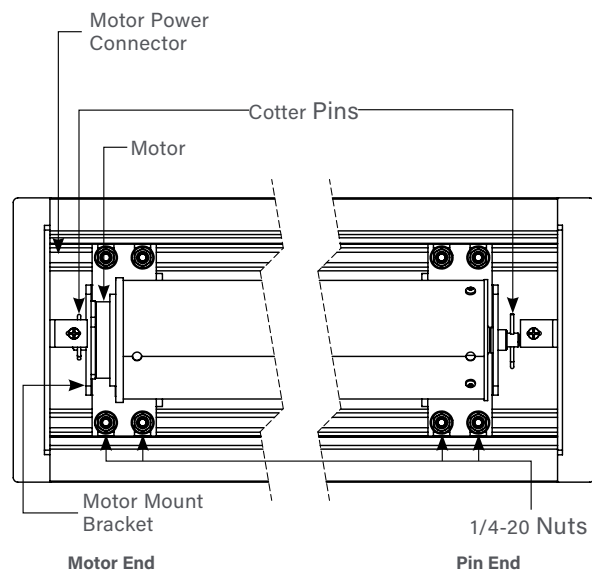

Figure 2

SCREEN AND ROLLER ASSEMBLY INSTALLATION (CONT.)

Replacement Motor Instruction

Rated torque of model DL45E-10/26 is 10 N/m with a duty cycle of 1 min. on / 3 min. off.

Rated torque of model DL45EQ-6/28 is 6 N/m with a duty cycle of 1 min. on / 3 min. off.

Motor is intended for use in Da-Lite screens incorporating a 3.00" and 3.25" roller diameter.

1. Make sure motor collar is on motor.
2. Collars keyway must line up with the key on the motor.
3. Secure motor drive wheel on output shaft of motor and insert retaining clip.

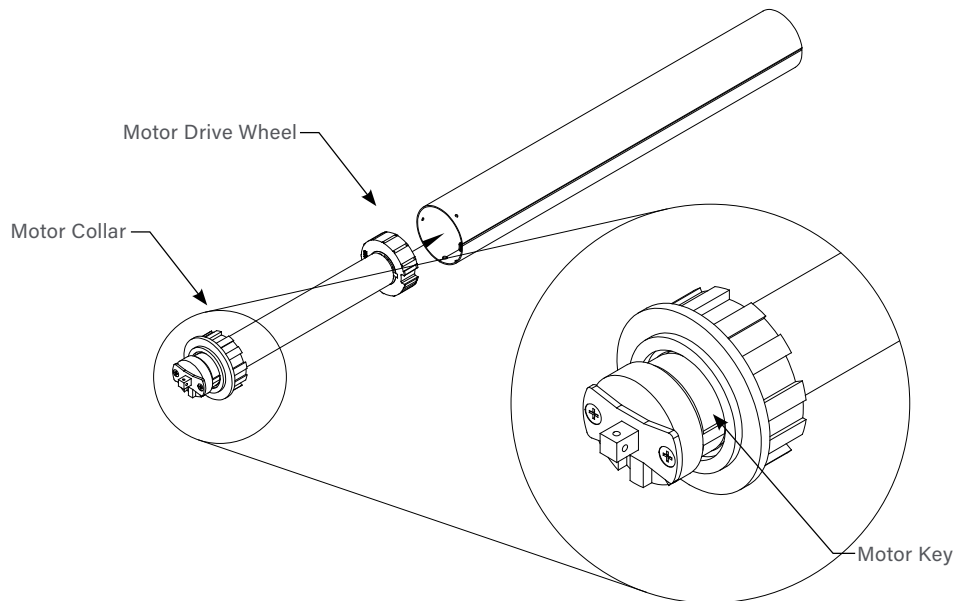

4. Insert motor in tube with seam of tube lined up with drive wheel and collar cutouts.

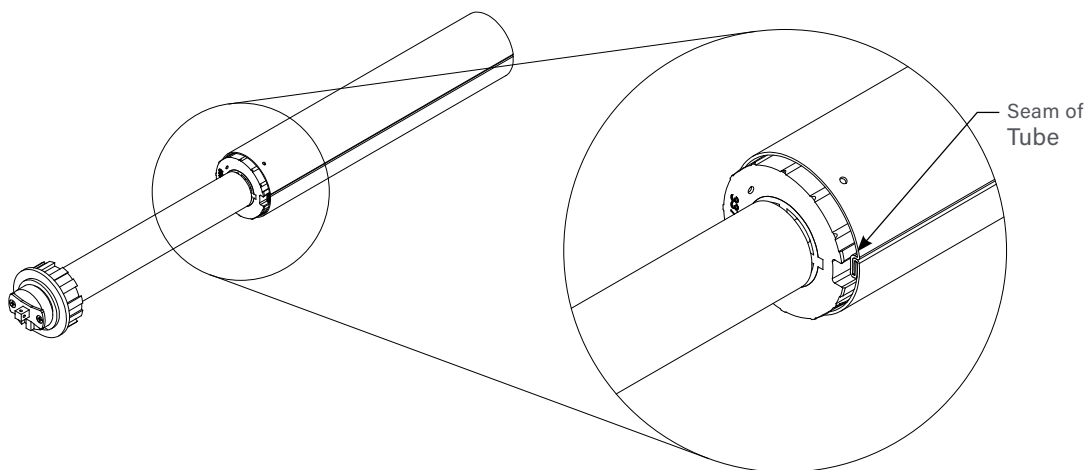

WIRING DIAGRAM FOR FOR 120V SCREENS

120V Wiring Diagram

IMPORTANT NOTE: The wall switch is REQUIRED to make any limit switch adjustments, EVEN if a third party control system is used. Therefore, it is advised to locate the wall switch in an accessible location.

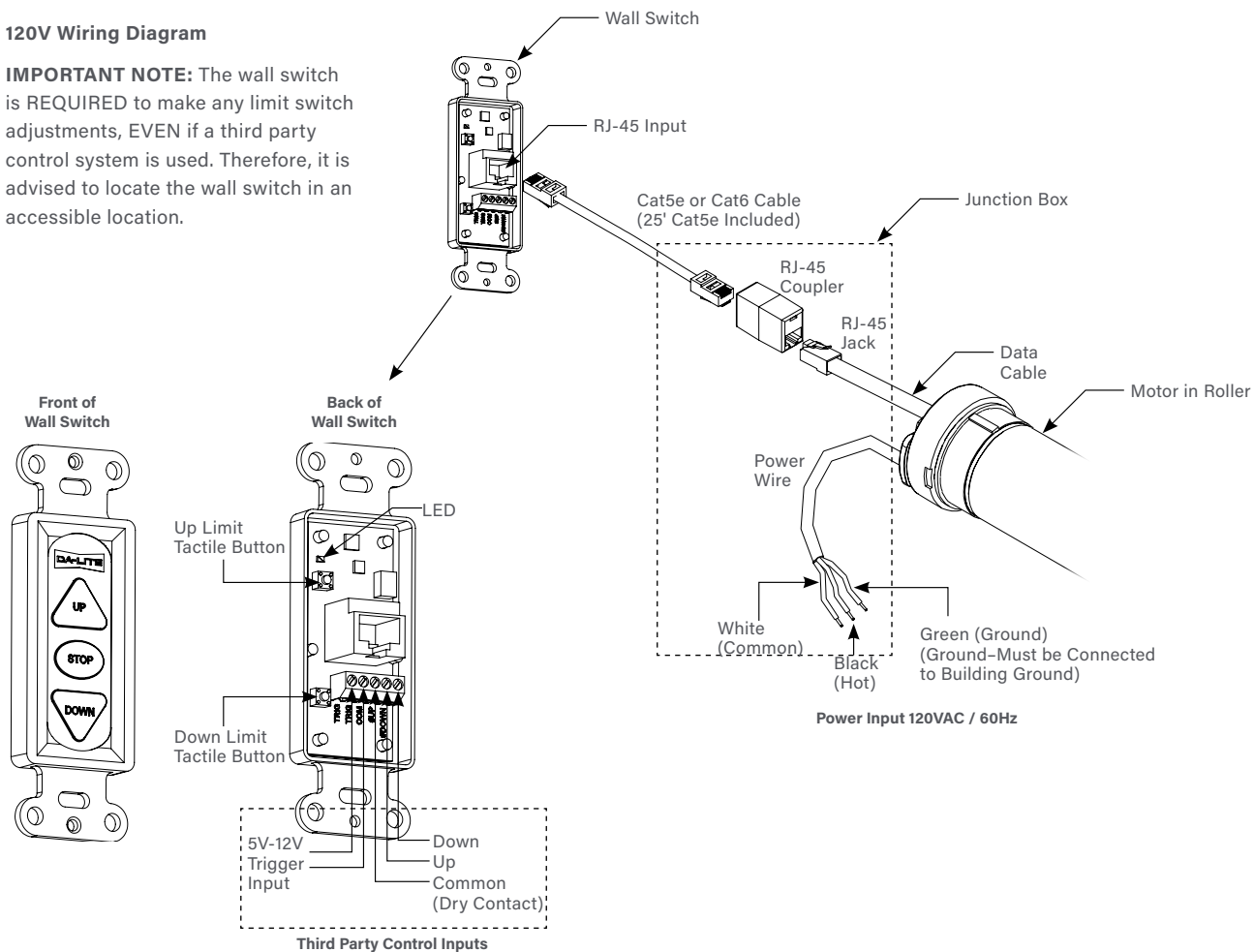

THIRD PARTY CONTROL

Control Panel

A control panel may be connected to the wall switch by using the dry contact Up, Down and Common connections. The control panel must provide a momentary, dry contact closure of at least 1/2 second.

1. Use 3-conductor 20-24 gauge wire to connect the control panel to the Screen Controller.
2. A momentary closure across the COM and #UP inputs will be an "up" command.
3. A momentary closure across the COM and #DN inputs will be a "down" command.
4. A momentary closure across the COM, #UP and #DN inputs will be a "stop" command.

Projector Trigger

When a 5-12V signal is received from a projector trigger output (or trigger output from any other device) the screen will move to the down position. When voltage is removed the screen will run to the up position.

Use 2-conductor 18-24 gauge wire to extend the low voltage connection from the 5 to 12-volt trigger output to the TRIG input on the wall switch.

NOTE: When extending the low voltage connection from the trigger output polarity does not matter. The wires are interchangeable.

WIRING DIAGRAM FOR 230V SCREENS

230V Wiring Diagram

IMPORTANT NOTE: The wall switch is REQUIRED to make any limit switch adjustments, EVEN if a third party control system is used. Therefore, it is advised to locate the wall switch in an accessible location.

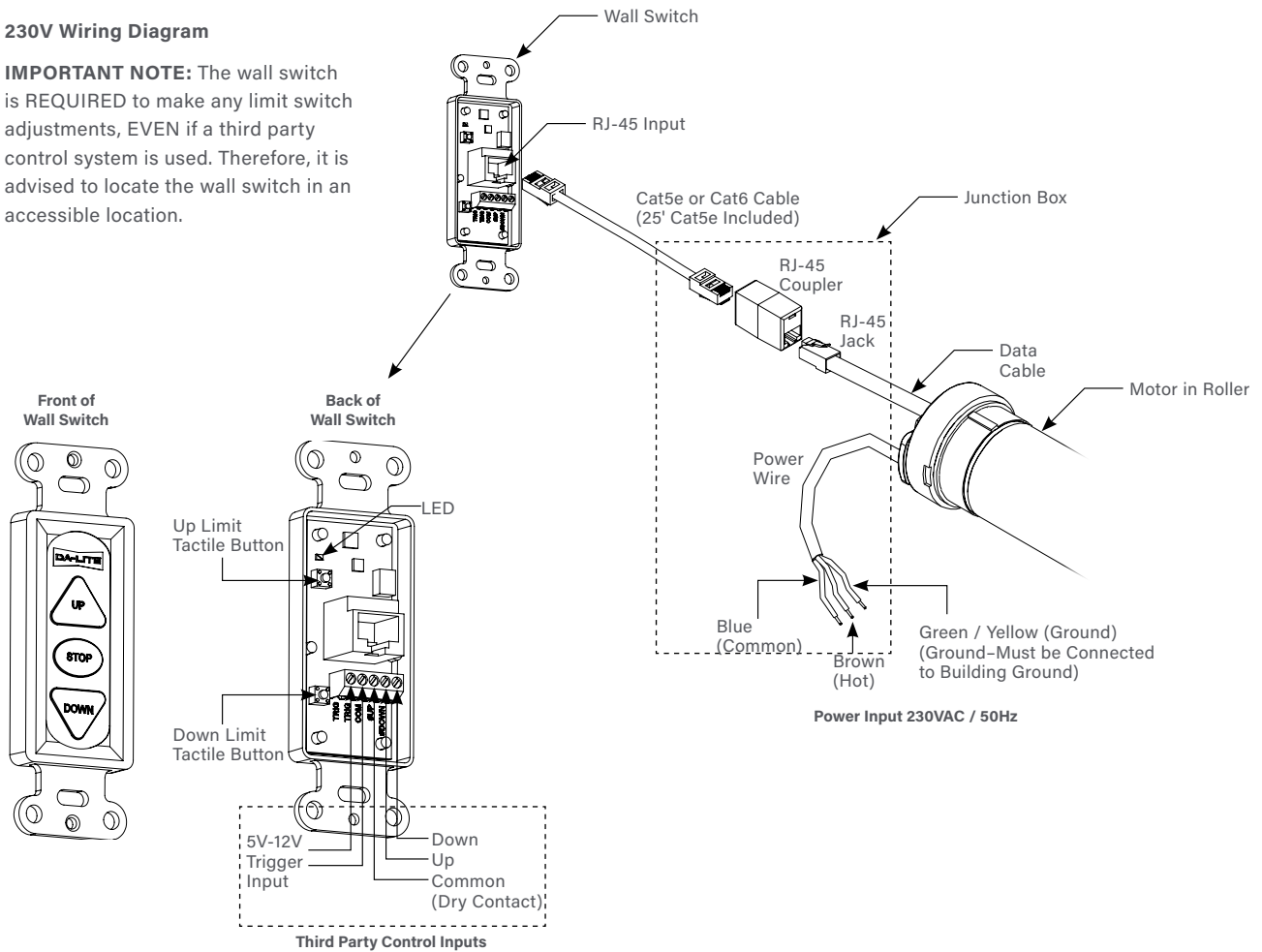

THIRD PARTY CONTROL

Control Panel

A control panel may be connected to the wall switch by using the dry contact Up, Down and Common connections. The control panel must provide a momentary, dry contact closure of at least 1/2 second.

1. Use 3-conductor 20-24 gauge wire to connect the control panel to the Screen Controller.
2. A momentary closure across the COM and #UP inputs will be an "up" command.
3. A momentary closure across the COM and #DN inputs will be a "down" command.
4. A momentary closure across the COM, #UP and #DN inputs will be a "stop" command.

Projector Trigger

When a 5-12V signal is received from a projector trigger output (or trigger output from any other device) the screen will move to the down position. When voltage is removed the screen will run to the up position.

Use 2-conductor 18-24 gauge wire to extend the low voltage connection from the 5 to 12-volt trigger output to the TRIG input on the wall switch.

NOTE: When extending the low voltage connection from the trigger output polarity does not matter. The wires are interchangeable.

WIRING DIAGRAM FOR 230V SCREENS (CONT.)

230V Wiring Diagram with Optional European Style Wall Switch

Use 3-conductor 20-24 gauge wire to connect European style wall switch to the COM, #UP, and #DOWN to the limit adjustment wall switch

IMPORTANT NOTE: The European style wall switch is for operation only and CANNOT be used to make limit switch adjustments. Therefore, it is advised to locate the limit adjustment wall switch in an accessible location.

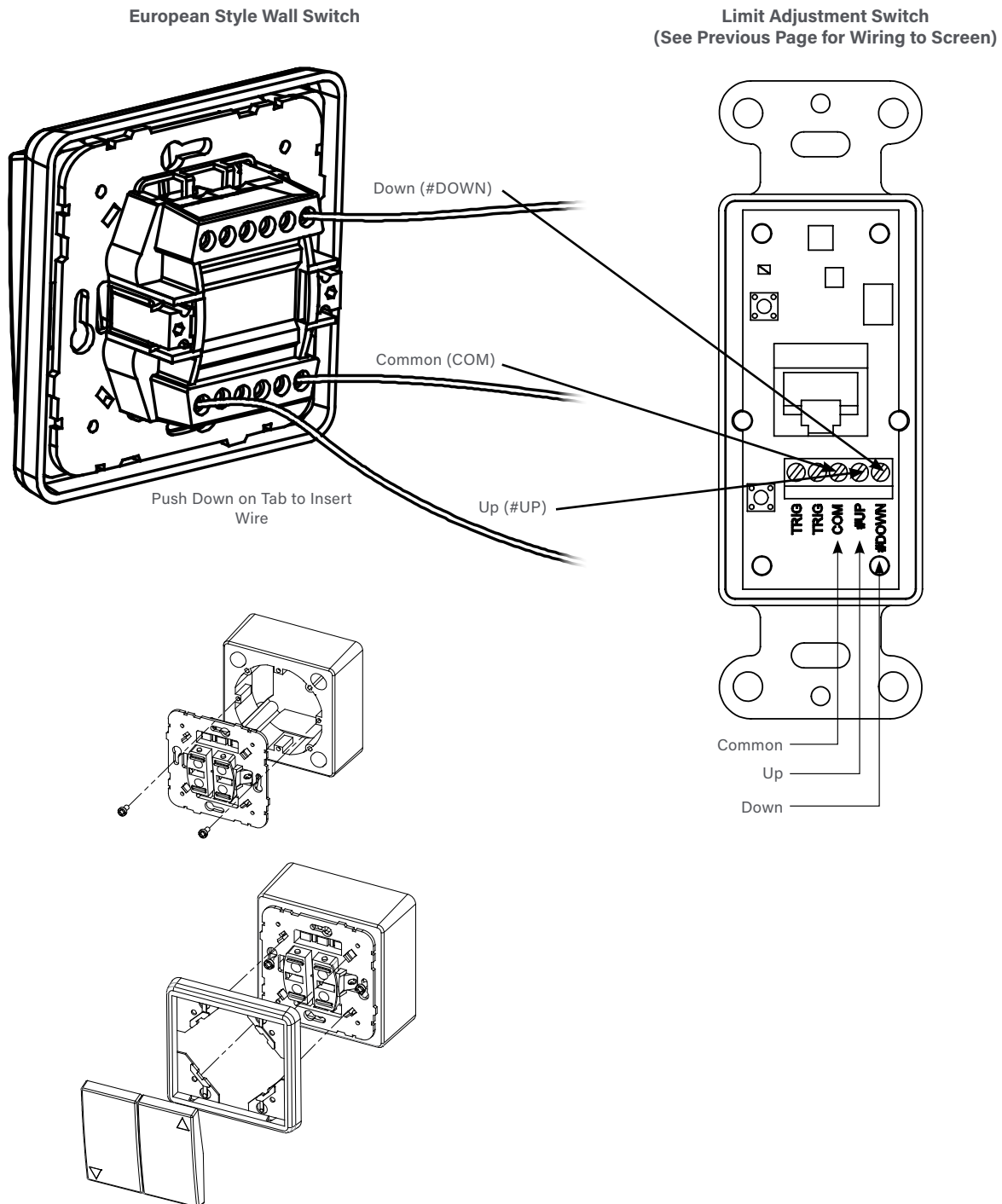

SCREEN ADJUSTMENT

If your Advantage was ordered as a complete unit, the up and down limits were pre-set by Da-Lite. If your screen and roller assembly was ordered separately from the case, or if general adjustment is needed, please follow the steps below and refer to the Wiring Diagram.

1. Locate the wall switch and remove the cover plate from the wall switch and remove the switch from the junction box.
2. Locate the two tactile buttons on the back of the switch. They are black round buttons on silver plates.
3. To adjust the down limit switch, press and hold the down tactile button until the LED on the back of the switch turns solid red. This will put the motor in limit set mode. Turn the wall switch over and use the down button on the front of the switch. Press and hold the down button until the desired down position is reached. If you travel too far down, press the up button to move the screen upward. If you press and let go of either the up or down buttons, the motor will do a small jog in that direction for fine adjustment of the screen. Once the desired position is reached, turn the switch over; press and hold the down tactile button until the LED on back of switch blinks red twice. The down limit is now set.

NOTE: If the screen is in limit set mode and no buttons are pushed for 20 seconds, the LED on the back of the wall switch will turn off, the motor will return to run mode and no changes will be saved. If this occurs, return to step 3 for down limit adjustment or step 4 for up limit adjustment.

4. To adjust the up limit switch, press and hold the up tactile button until the LED on the back of the switch turns solid green. This will put the motor in limit set mode. Turn the wall switch over and use the up button on the front of the switch. Press and hold the up button until the desired up position is reached. If you travel too far up, press the down button to move the screen downward. If you press and let go of either the up or down buttons, the motor will do a small jog in that direction for fine adjustment of the screen. Once the desired position is reached, turn the switch over; press and hold the up tactile button until the LED on back of switch blinks green twice. The up limit is now set.
5. To test the limit switch settings, press and release the up or down buttons on the switch to operate the screen.

6. Replace the switch and cover plate on the wall.

IMPORTANT NOTE: The wall switch is REQUIRED to make any limit switch adjustments, even if a third party control system is used. Therefore, it is advised to wire the switch or provide a 3-conductor connection that is accessible.

⚠ CAUTION: Do not adjust for more drop than what was ordered. At least 1-1/2 wraps of fabric must remain on the roller. This screen comes standard with 0" or 2" black at the top. See the specification data sheet for details.

⚠ ATTENTION! N'effectuez pas de réglage pour obtenir un déroulement supérieur à celui commandé. Au moins 1 à 1/2 tour de toile doit être maintenu sur le cylindre. Cet écran est doté de série d'une bande noire supérieure de 0 cm (0 po) ou 5 cm (2 po). Consultez la fiche technique pour plus de renseignements.

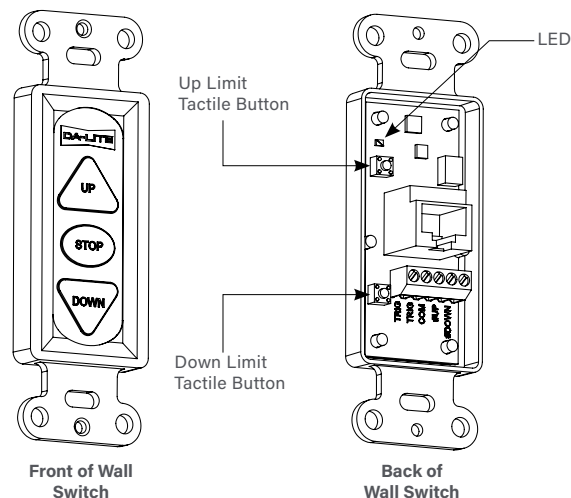

OPERATION OF SCREEN

Operation & Limit Adjustment Wall Switch

1. Press "DOWN" button on screen switch and screen will deploy out of case in downward direction.
2. Press "STOP" button on screen switch and screen will stop if in movement.
3. Press "UP" button on screen switch and screen will retract upward into case.

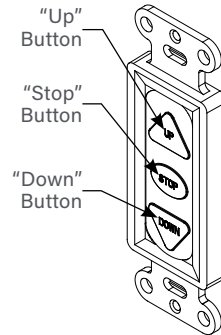

European Style Wall Switch (220V models only)

1. Press "DOWN" button on screen switch and screen will deploy out of case in downward direction.
2. Press "UP" button on screen switch and screen will retract upward into case.

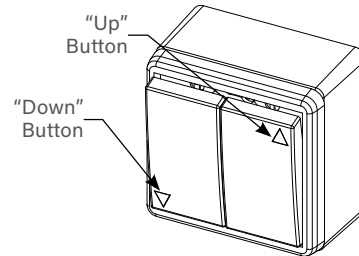

TROUBLESHOOTING

SYMPTOM	CAUSE	SOLUTION
Screen will not operate and motor does not hum.	Incorrect line voltage.	Verify 115-125V (or 220-240V). If insufficient voltage, rewire incoming electric line.
	Blown fuse.	Replace fuse.
	Tripped circuit breaker.	Reset circuit breaker.
	No power to operating switch or junction.	Check above. Tighten all loose wire connections. Correct any improper connections. Down Position Check for power across black and white leads. Up Position Check for power across red and white leads.
Screen will not operate and motor does not hum. Power at junction box.	Thermal overload tripped.	Let motor cool down for 15 minutes. Try again.
	Broken wire in the "down" or "up" position.	Check for continuity. Cut off old splice and reconnect.
	Defective motor, limit switch or capacitor.	Replace motor assembly. NOTE: Motor is a sealed assembly.
	Capacitor burned out.	Replace motor assembly.
Screen does not stop at correct position.	Limit switch out of adjustment.	See Screen Adjustment section.
Noise. NOTE: Screen will operate with a low pitched hum.	Squeaking, rubber end plug rubbing on motor.	Center roller in case.
	Grinding. Foreign object in screen rubbing on roller or fabric.	Remove.
	Gear noise.	Replace motor assembly.
Coasting.	Defective brake.	Replace motor assembly.
Fabric hangs crooked.	Screen not installed properly.	Check for level and plumb.
	Fabric has backed up inside case.	Adjust "down" limit switch slowly until roller is exposed and wrinkle comes out, then readjust for proper drop.
	Fabric is damaged.	Replace fabric.

CONDITIONS FOR TRANSPORTATION AND STORAGE

- Temperature: Between 40 - 100°F (5 - 40°C)
- Relative Humidity: 30% to 70%, non-condensing
- Always keep the projection screen horizontal during transport and storage
- Make sure the entire package is supported when stored
- Do not stack more than six projection screens on top of each other
- Make sure the heaviest package is placed at the bottom of the stack

Screen surface should be allowed to air out once every two months, or otherwise used on a regular basis, if the temperature is above 72°F (22°C) and at least once every month if the temperature goes above 85°F (30°C).

LIMITED FIVE-YEAR WARRANTY ON DA-LITE PRESENTATION PRODUCTS

Legrand AV Inc. warrants certain Da-Lite branded products to the original purchaser only, to be free from defects in materials and workmanship for a period of five (5) years from the date of purchase by the original purchaser; provided they are properly operated according to Da-Lite's instructions and are not damaged due to improper handling or treatment after shipment from the factory.

Limited five-year warranty applies to the following products:

Wireline Advantage®, Tensioned Advantage Series, Advantage Series, Tensioned Professional, Professional, Tensioned Contour®, Contour, Tensioned Cosmopolitan® Series, Cosmopolitan Series, Tensioned Designer Contour, Designer Contour, Studio, Arena, Parallax®, Parallax Thin, FullVision, UTB Contour, Cinema Contour, Da-Snap, IDEA™ Screen, IDEA Panoramic, Fast-Fold® Deluxe, Fast-Fold Deluxe Drapery Kits, Da-Plex, and Rear Projection Mirror System.

This warranty does not apply to equipment showing evidence of misuse, abuse or accidental damage, or which has been tampered with or repaired by a person other than authorized Da-Lite personnel.

Da-Lite's sole obligation under this warranty shall be to repair or to replace (at Da-Lite's option) the defective part of the merchandise. Returns for service should be made to your Da-Lite dealer. If it is necessary for the dealer to return the screen or part to Da-Lite, transportation expenses to and from Da-Lite are payable by the purchaser and Da-Lite is not responsible for damage in shipment. To protect yourself against damage or loss in transit, insure the product and prepay all transportation expenses.

TO THE MAXIMUM EXTENT PERMITTED BY APPLICABLE LAW, THIS WARRANTY IS IN LIEU OF ALL OTHER WARRANTIES, EXPRESS OR IMPLIED, INCLUDING WARRANTIES AS TO FITNESS FOR USE AND MERCHANTABILITY. Any implied warranties of fitness for use, or merchantability, that may be mandated by statute or rule of law are limited to the five (5) year warranty period. This warranty gives you specific legal rights, and you may also have other rights, which vary from state-to-state. **TO THE MAXIMUM EXTENT PERMITTED BY APPLICABLE LAW, NO LIABILITY IS ASSUMED FOR EXPENSES OR DAMAGES RESULTING FROM INTERRUPTION IN OPERATION OF EQUIPMENT, OR FOR INCIDENTAL, DIRECT, OR CONSEQUENTIAL DAMAGES OF ANY NATURE.**

In the event that there is a defect in materials or workmanship of a Da-Lite product, you may contact Customer Care at 3100 North Detroit Street, Warsaw, IN 46582, (866) 977-3901.

IMPORTANT: THIS WARRANTY SHALL NOT BE VALID AND DA-LITE BRANDED PRODUCTS SHALL NOT BE BOUND BY THIS WARRANTY IF THE PRODUCT IS NOT OPERATED IN ACCORDANCE WITH THE DA-LITE WRITTEN INSTRUCTIONS.

Keep your sales receipt to prove the date of purchase and your original ownership.

DA-LITE
A brand of  **legrand**



Advantage[®] with SightLine[™]

USER MANUAL

210748 Rev D

ORIGINAL INSTRUCTIONS

DISCLAIMER

Legrand AV Inc. and its affiliated companies and subsidiaries (collectively, "Legrand AV"), intend to make this manual accurate and complete. However, Legrand AV makes no claim that the information contained herein covers all details, conditions or variations, nor does it provide for every possible contingency in connection with the installation or use of the products described herein. The content herein is subject to change without notice or obligation of any kind. To the maximum extent permitted by applicable law, Legrand AV makes no representation or warranty, expressed or implied, regarding the information contained herein. Furthermore, Legrand AV assumes no responsibility for accuracy, completeness or sufficiency of the information contained in this document.

Da-Lite® is a registered trademark of Legrand AV. All rights reserved.

IMPORTANT SAFETY INSTRUCTIONS

When using your video equipment, basic safety precautions should always be followed, including the following:

1. Read and understand all instructions before using.
2. Maximum surrounding air temperature 122°F (50°C).
3. Main disconnect must be incorporated in the fixed wiring in accordance with the wiring rules.
4. Rated for indoor use only.
5. Use copper rated conductors rated 167°F (75°C) or higher.
6. If the supply cord is damaged, it must be replaced by the manufacturer, its service agent or similarly qualified persons in order to avoid hazard.
7. Supplied drive is only intended for use in Da-Lite screen models Advantage, Contour, and Cosmopolitan.
8. Position the cord so that it will not be tripped over, pulled, or contact hot surfaces.
9. If an extension cord is necessary, a cord with a current rating at least equal to that of the appliance should be used. Cords rated for less amperage than the appliance may overheat.
10. To reduce the risk of electric shock, do not disassemble this appliance. Contact an authorized service dealer when repair work is required. Incorrect reassembly can cause electric shock when the appliance is used subsequently.
11. The use of an accessory attachment not recommended by the manufacturer may cause a risk of fire, electric shock, or injury to persons.
12. Failure to provide adequate structural strength for this component can result in serious personal injury or damage to equipment! It is the installer's responsibility to make sure the structure to which this component is attached can support the weight of all equipment. Reinforce the structure as required before installing the component.
13. Use this projection screen only for its intended use as described in these instructions. Do not use attachments not recommended by the manufacturer.

Save These Instructions

ADVANTAGE WITH SIGHTLINE SUGGESTED METHODS OF INSTALLATION

Method 1

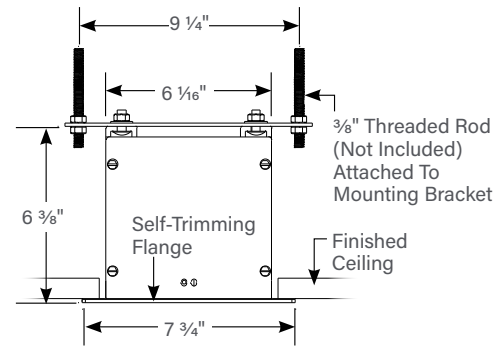
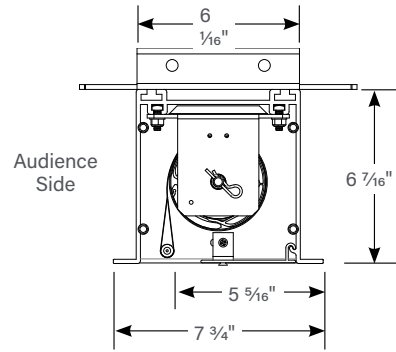
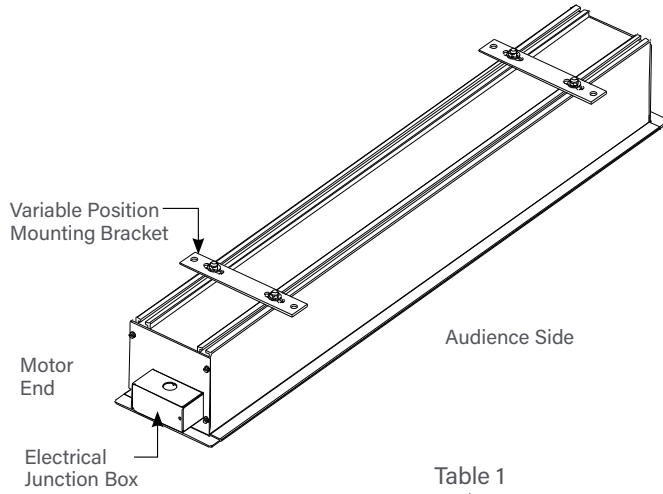

Table 1

Case Length	Number of Mounting Brackets
97.25" and Under	2
Over 97.25" to 170"	3

Method 2

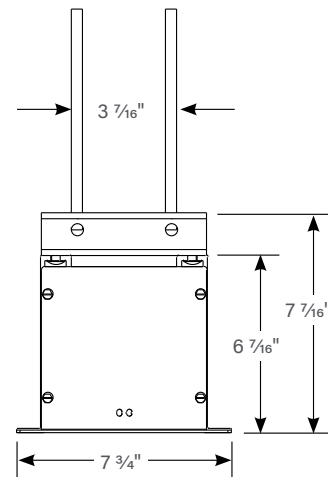
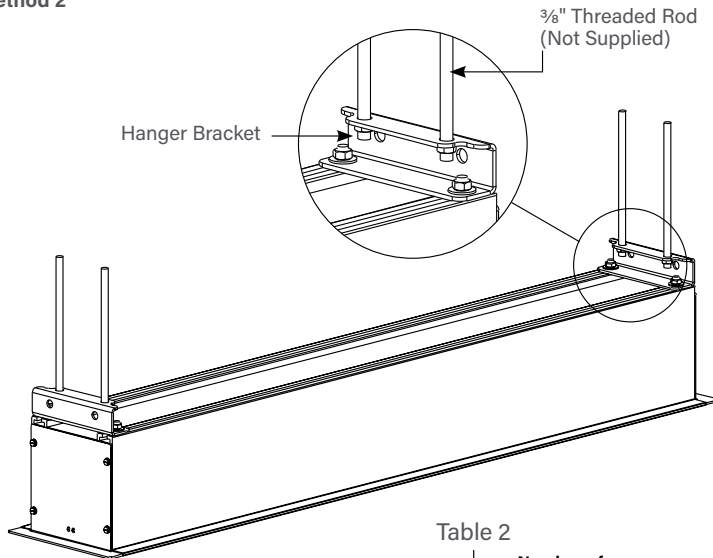
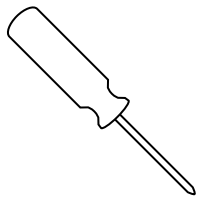

Table 2

Case Length	Number of Mounting Brackets
170" and Under	2

TOOLS REQUIRED FOR INSTALLATION



#2 Phillips
Screwdriver

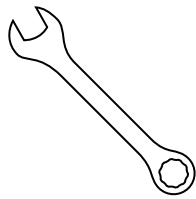

1/2" Open Wrench
or Socket Driver

PRE-INSTALLATION

1. Carefully unpack case from shipping carton.
2. Set aside the Installation Kit. Items inside will be used during installation.
3. Make sure to recheck measurement of case for proper installation clearance.
4. Remove any protective foam covering the outside of the case.
5. For shipping purposes, foam is also inserted between the roller brackets and end caps (Figure 1). Remove these foam blocks from the ends.
6. Remove the hanger brackets from the top of the case using a 1/2" wrench. Do not discard the hardware; it will be used during case installation to re-attach the hanger brackets for mounting.

CASE INSTALLATION

1. Hang case and attach to support structure with bolts.
See Suggested Methods of Installation.
2. Tighten bolts until trim flange is flush with ceiling.
NOTE: For proper operation, case must be levelled side to side and front to back.
3. Remove 2 screws to open junction box. Install electrical connections that apply to your unit. Make sure to review the wiring diagram for proper hook up. Replace junction box cover and secure with 2 screws.

NOTE: Must be installed in accordance with the requirements of the Local Building Codes, the Canadian Electrical Code (CEC), CAN/CSA C22.1 and the National Electric Code (NEC), NFPA 70.

If your case was ordered in advance of the screen and roller assembly, your installation is now complete. Continue to step 4 if your Advantage was ordered as a complete unit.

4. Carefully remove paper and tape from roller assembly. DO NOT use a knife or sharp object to cut tape; you will damage the screen. Pull orange string..
5. Test installation by running screen up and down a few times.
Be prepared to stop screen should any objects obstruct the movement of the screen. To prevent damage to the motor, the standard duty cycle is 1 minute on and 3 minutes off.

SCREEN AND ROLLER ASSEMBLY INSTALLATION

Follow these steps if your screen and roller assembly was ordered separately from the case.

1. Remove the access door. First, remove the 2 screws from the ends. Be sure to support the door during this step to avoid injury. Then lift the door slightly and pull away from the edge of the case (Figure 1).
2. Carefully unpack screen and roller assembly. Leave packing paper on roller.
3. To install screen and roller assembly, loosen (but do not remove) four 1/4-20 nuts securing pin end bracket (opposite end from the junction box) to the case housing. Slide the pin end bracket towards the end of the case (Figure 2).
4. Insert the motor end square shaft into the motor end bracket (junction box end) and secure with the cotter pin. (Figure 2).
5. Moving to the pin end of the case, slide the pin end bracket until the hole fits securely over the pin and secure with the cotter pin. Tighten the 1/4-20 nuts on the pin end bracket securely (Figure 2).
6. Complete electrical hook-up by snapping motor wire connector into case connector (Figure 2).
7. Carefully remove paper and tape from roller assembly. **DO NOT** use a knife or sharp object to cut tape; you will damage the screen. Pull orange string.
8. Test installation by running screen up and down a few times. Be prepared to stop screen should any objects obstruct the movement of the screen. To prevent damage to the motor, the standard duty cycle is 1 minute on and 3 minutes off.
9. Re-install the access door. Procedure is the reverse of step 1 listed above.

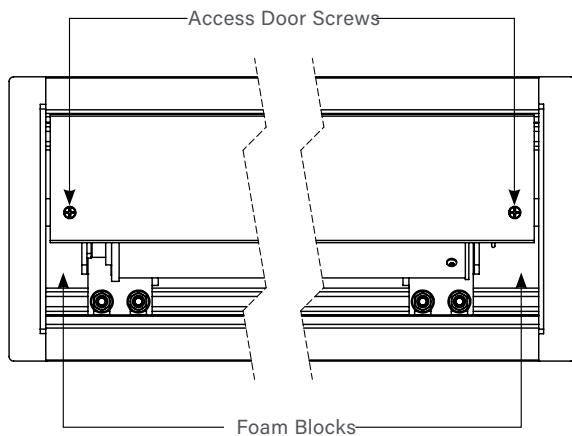

Figure 1

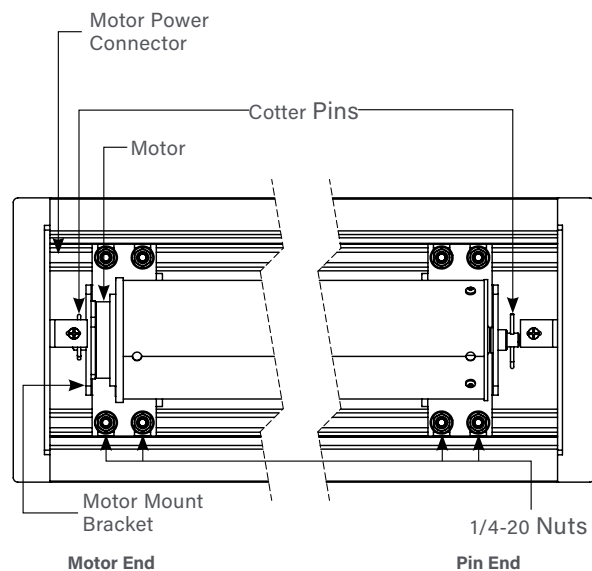

Figure 2

SCREEN AND ROLLER ASSEMBLY INSTALLATION (CONT.)

Replacement Motor Instruction

Rated torque of model DL45E-10/26 is 10 N/m with a duty cycle of 1 min. on / 3 min. off.

Rated torque of model DL45EQ-6/28 is 6 N/m with a duty cycle of 1 min. on / 3 min. off.

Motor is intended for use in Da-Lite screens incorporating a 3.00" and 3.25" roller diameter.

1. Make sure motor collar is on motor.
2. Collars keyway must line up with the key on the motor.
3. Secure motor drive wheel on output shaft of motor and insert retaining clip.

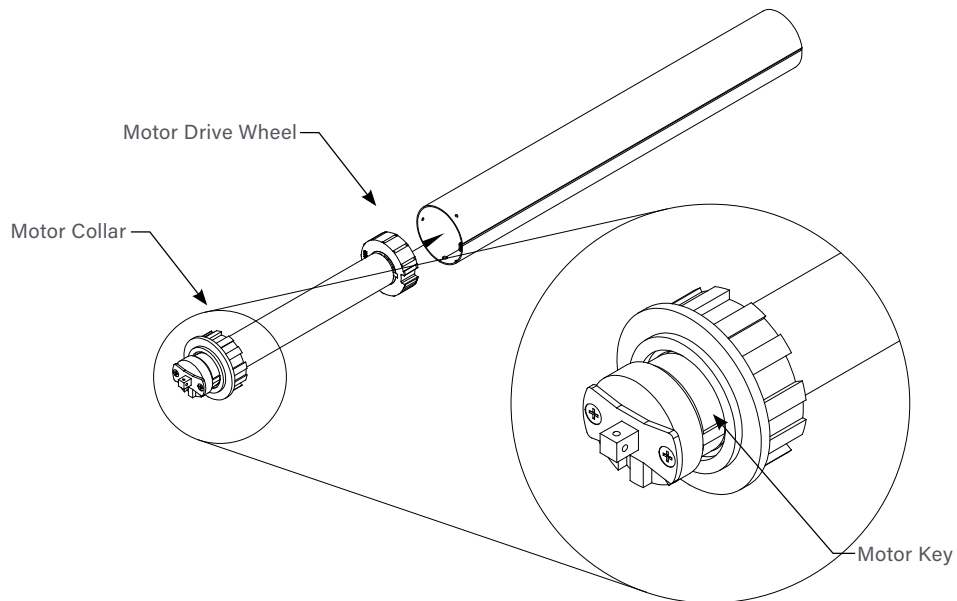

4. Insert motor in tube with seam of tube lined up with drive wheel and collar cutouts.

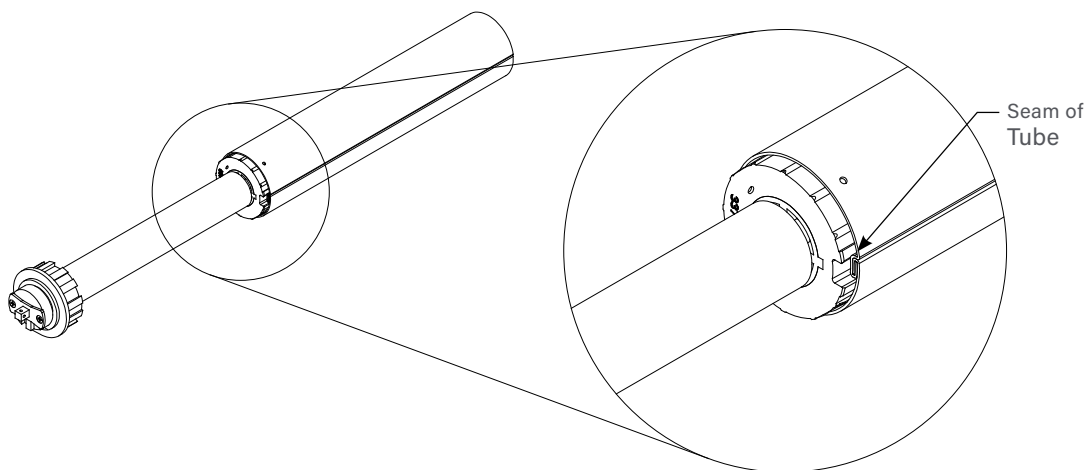

WIRING DIAGRAM FOR FOR 120V SCREENS

120V Wiring Diagram

IMPORTANT NOTE: The wall switch is REQUIRED to make any limit switch adjustments, EVEN if a third party control system is used. Therefore, it is advised to locate the wall switch in an accessible location.

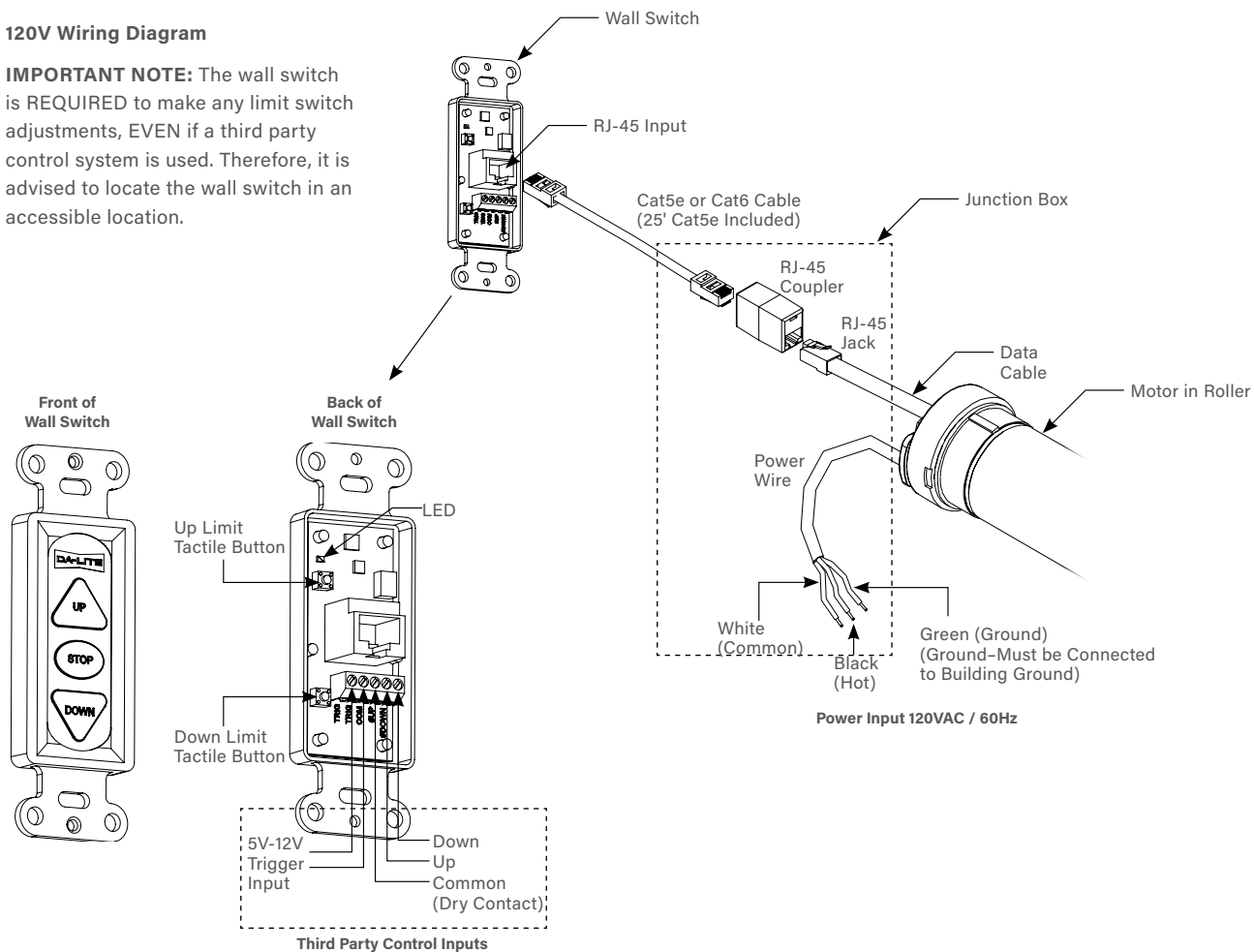

THIRD PARTY CONTROL

Control Panel

A control panel may be connected to the wall switch by using the dry contact Up, Down and Common connections. The control panel must provide a momentary, dry contact closure of at least 1/2 second.

1. Use 3-conductor 20-24 gauge wire to connect the control panel to the Screen Controller.
2. A momentary closure across the COM and #UP inputs will be an "up" command.
3. A momentary closure across the COM and #DN inputs will be a "down" command.
4. A momentary closure across the COM, #UP and #DN inputs will be a "stop" command.

Projector Trigger

When a 5-12V signal is received from a projector trigger output (or trigger output from any other device) the screen will move to the down position. When voltage is removed the screen will run to the up position.

Use 2-conductor 18-24 gauge wire to extend the low voltage connection from the 5 to 12-volt trigger output to the TRIG input on the wall switch.

NOTE: When extending the low voltage connection from the trigger output polarity does not matter. The wires are interchangeable.

WIRING DIAGRAM FOR 230V SCREENS

230V Wiring Diagram

IMPORTANT NOTE: The wall switch is REQUIRED to make any limit switch adjustments, EVEN if a third party control system is used. Therefore, it is advised to locate the wall switch in an accessible location.

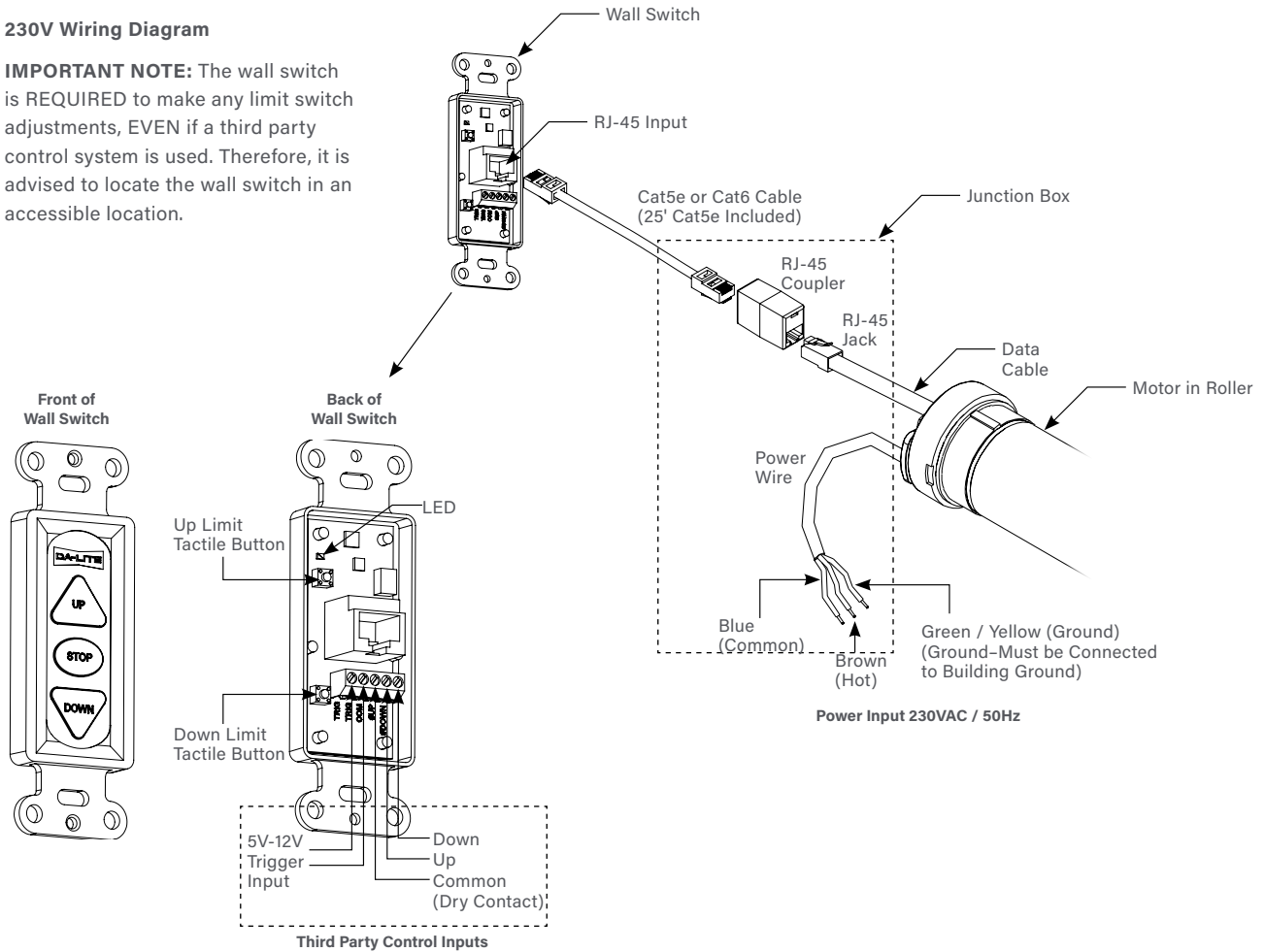

THIRD PARTY CONTROL

Control Panel

A control panel may be connected to the wall switch by using the dry contact Up, Down and Common connections. The control panel must provide a momentary, dry contact closure of at least 1/2 second.

1. Use 3-conductor 20-24 gauge wire to connect the control panel to the Screen Controller.
2. A momentary closure across the COM and #UP inputs will be an "up" command.
3. A momentary closure across the COM and #DN inputs will be a "down" command.
4. A momentary closure across the COM, #UP and #DN inputs will be a "stop" command.

Projector Trigger

When a 5-12V signal is received from a projector trigger output (or trigger output from any other device) the screen will move to the down position. When voltage is removed the screen will run to the up position.

Use 2-conductor 18-24 gauge wire to extend the low voltage connection from the 5 to 12-volt trigger output to the TRIG input on the wall switch.

NOTE: When extending the low voltage connection from the trigger output polarity does not matter. The wires are interchangeable.

WIRING DIAGRAM FOR 230V SCREENS (CONT.)

230V Wiring Diagram with Optional European Style Wall Switch

Use 3-conductor 20-24 gauge wire to connect European style wall switch to the COM, #UP, and #DOWN to the limit adjustment wall switch

IMPORTANT NOTE: The European style wall switch is for operation only and CANNOT be used to make limit switch adjustments. Therefore, it is advised to locate the limit adjustment wall switch in an accessible location.

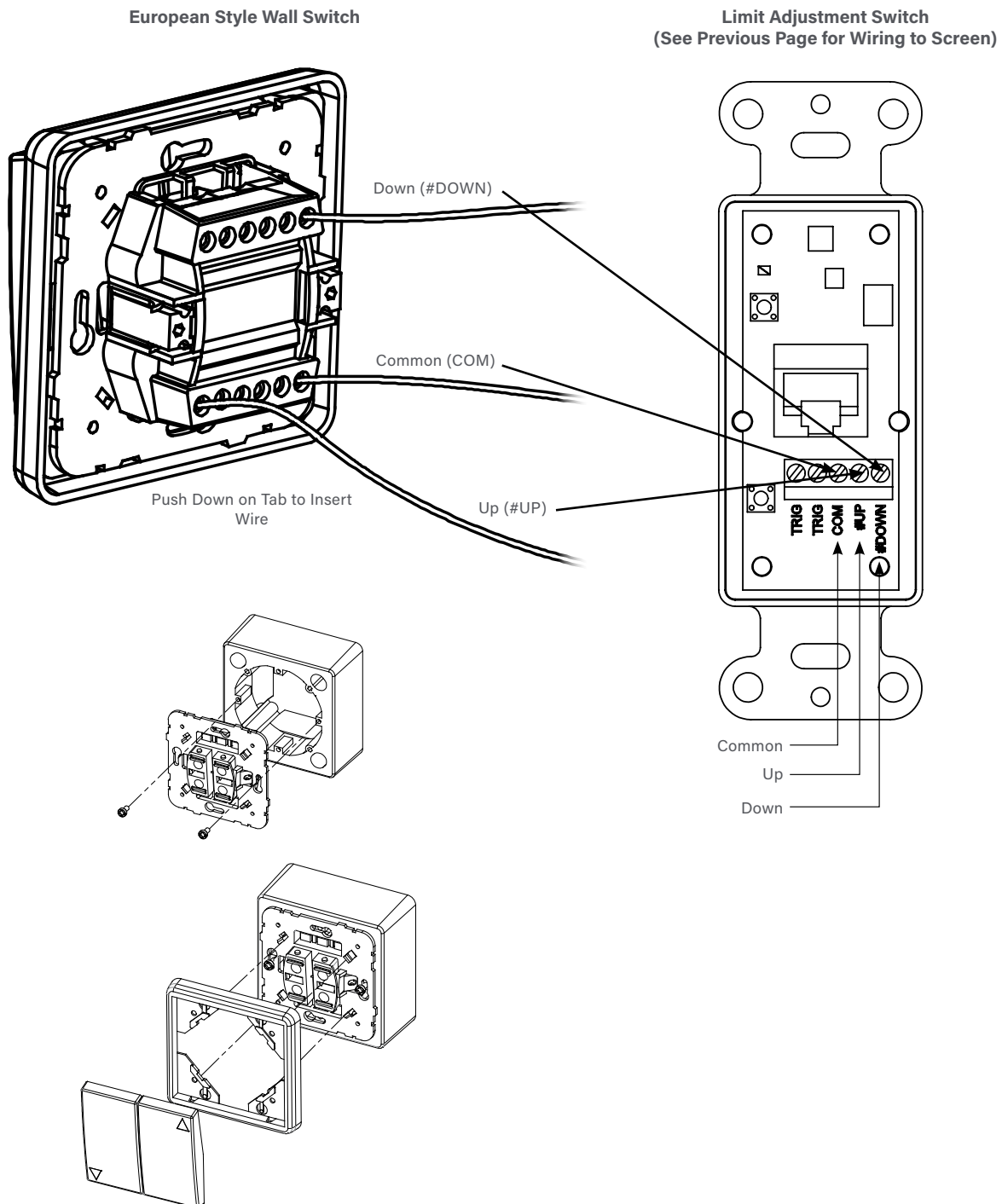

SCREEN ADJUSTMENT

If your Advantage with SightLine was ordered as a complete unit, the up and down limits were pre-set by Da-Lite at 24". The desired amount of cable drop can be adjusted according to the instructions below. If your screen and roller assembly was ordered separately from the case, or if general adjustment is needed, please follow the steps below and refer to the Wiring Diagram.

1. Locate the wall switch and remove the cover plate from the wall switch and remove the switch from the junction box.
2. Locate the two tactile buttons on the back of the switch. They are black round buttons on silver plates.
3. To adjust the down limit switch, press and hold the down tactile button until the LED on the back of the switch turns solid red. This will put the motor in limit set mode. Turn the wall switch over and use the down button on the front of the switch. Press and hold the down button until the desired down position is reached. If you travel too far down, press the up button to move the screen upward. If you press and let go of either the up or down buttons, the motor will do a small jog in that direction for fine adjustment of the screen. Once the desired position is reached, turn the switch over; press and hold the down tactile button until the LED on back of switch blinks red twice. The down limit is now set.

NOTE: If the screen is in limit set mode and no buttons are pushed for 20 seconds, the LED on the back of the wall switch will turn off, the motor will return to run mode and no changes will be saved. If this occurs, return to step 3 for down limit adjustment or step 4 for up limit adjustment.

4. To adjust the up limit switch, press and hold the up tactile button until the LED on the back of the switch turns solid green. This will put the motor in limit set mode. Turn the wall switch over and use the up button on the front of the switch. Press and hold the up button until the desired up position is reached. If you travel too far up, press the down button to move the screen downward. If you press and let go of either the up or down buttons, the motor will do a small jog in that direction for fine adjustment of the screen. Once the desired position is reached, turn the switch over; press and hold the up tactile button until the LED on back of switch blinks green twice. The up limit is now set.
5. To test the limit switch settings, press and release the up or down buttons on the switch to operate the screen.

6. Replace the switch and cover plate on the wall.

IMPORTANT NOTE: The wall switch is REQUIRED to make any limit switch adjustments, even if a third party control system is used. Therefore, it is advised to wire the switch or provide a 3-conductor connection that is accessible.

⚠ CAUTION: Do not adjust for more than 70" of wire drop. At least 2 wraps of wire must remain on the roller. This screen comes standard with 0" to 70" of wire drop. See the specification data sheet for details.

⚠ ATTENTION! La longueur de la chute de câble ne doit pas dépasser 170 cm (60 po). Au moins deux enroulements de câble doivent demeurer sur le rouleau. Cet écran est livré de série avec une chute de câble de 0 cm/po à 170 cm (60 po). Consultez la fiche technique pour plus de renseignements.

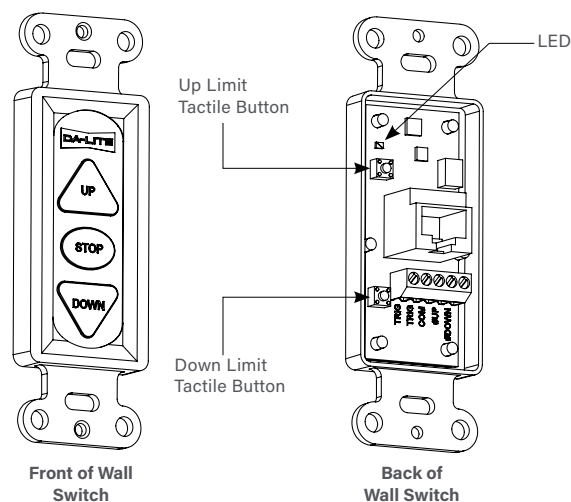

OPERATION OF SCREEN

Operation & Limit Adjustment Wall Switch

1. Press "DOWN" button on screen switch and screen will deploy out of case in downward direction.
2. Press "STOP" button on screen switch and screen will stop if in movement.
3. Press "UP" button on screen switch and screen will retract upward into case.

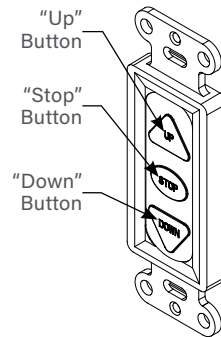

European Style Wall Switch (220V models only)

1. Press "DOWN" button on screen switch and screen will deploy out of case in downward direction.
2. Press "UP" button on screen switch and screen will retract upward into case.

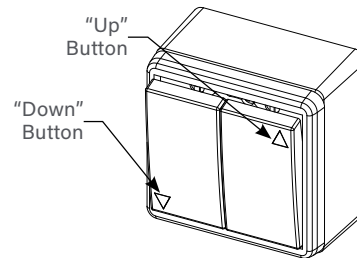

TROUBLESHOOTING

SYMPTOM	CAUSE	SOLUTION
Screen will not operate and motor does not hum.	Incorrect line voltage.	Verify 115-125V (or 220-240V). If insufficient voltage, rewire incoming electric line.
	Blown fuse.	Replace fuse.
	Tripped circuit breaker.	Reset circuit breaker.
	No power to operating switch or junction.	Check above. Tighten all loose wire connections. Correct any improper connections. Down Position Check for power across black and white leads. Up Position Check for power across red and white leads.
Screen will not operate and motor does not hum. Power at junction box.	Thermal overload tripped.	Let motor cool down for 15 minutes. Try again.
	Broken wire in the "down" or "up" position.	Check for continuity. Cut off old splice and reconnect.
	Defective motor, limit switch or capacitor.	Replace motor assembly. NOTE: Motor is a sealed assembly.
	Capacitor burned out.	Replace motor assembly.
Screen does not stop at correct position.	Limit switch out of adjustment.	See Screen Adjustment section.
Noise. NOTE: Screen will operate with a low pitched hum.	Squeaking, rubber end plug rubbing on motor.	Center roller in case.
	Grinding. Foreign object in screen rubbing on roller or fabric.	Remove.
	Gear noise.	Replace motor assembly.
Coasting.	Defective brake.	Replace motor assembly.
Fabric hangs crooked.	Screen not installed properly.	Check for level and plumb.
	Fabric has backed up inside case.	Adjust "down" limit switch slowly until roller is exposed and wrinkle comes out, then readjust for proper drop.
	Fabric is damaged.	Replace fabric.

CONDITIONS FOR TRANSPORTATION AND STORAGE

- Temperature: Between 40 - 100°F (5 - 40°C)
- Relative Humidity: 30% to 70%, non-condensing
- Always keep the projection screen horizontal during transport and storage
- Make sure the entire package is supported when stored
- Do not stack more than six projection screens on top of each other
- Make sure the heaviest package is placed at the bottom of the stack

Screen surface should be allowed to air out once every two months, or otherwise used on a regular basis, if the temperature is above 72°F (22°C) and at least once every month if the temperature goes above 85°F (30°C).

LIMITED FIVE-YEAR WARRANTY ON DA-LITE PRESENTATION PRODUCTS

Legrand AV Inc. warrants certain Da-Lite branded products to the original purchaser only, to be free from defects in materials and workmanship for a period of five (5) years from the date of purchase by the original purchaser; provided they are properly operated according to Da-Lite's instructions and are not damaged due to improper handling or treatment after shipment from the factory.

Limited five-year warranty applies to the following products:

Wireline Advantage®, Tensioned Advantage Series, Advantage Series, Tensioned Professional, Professional, Tensioned Contour®, Contour, Tensioned Cosmopolitan® Series, Cosmopolitan Series, Tensioned Designer Contour, Designer Contour, Studio, Arena, Parallax®, Parallax Thin, FullVision, UTB Contour, Cinema Contour, Da-Snap, IDEA™ Screen, IDEA Panoramic, Fast-Fold® Deluxe, Fast-Fold Deluxe Drapery Kits, Da-Plex, and Rear Projection Mirror System.

This warranty does not apply to equipment showing evidence of misuse, abuse or accidental damage, or which has been tampered with or repaired by a person other than authorized Da-Lite personnel.

Da-Lite's sole obligation under this warranty shall be to repair or to replace (at Da-Lite's option) the defective part of the merchandise. Returns for service should be made to your Da-Lite dealer. If it is necessary for the dealer to return the screen or part to Da-Lite, transportation expenses to and from Da-Lite are payable by the purchaser and Da-Lite is not responsible for damage in shipment. To protect yourself against damage or loss in transit, insure the product and prepay all transportation expenses.

TO THE MAXIMUM EXTENT PERMITTED BY APPLICABLE LAW, THIS WARRANTY IS IN LIEU OF ALL OTHER WARRANTIES, EXPRESS OR IMPLIED, INCLUDING WARRANTIES AS TO FITNESS FOR USE AND MERCHANTABILITY. Any implied warranties of fitness for use, or merchantability, that may be mandated by statute or rule of law are limited to the five (5) year warranty period. This warranty gives you specific legal rights, and you may also have other rights, which vary from state-to-state. **TO THE MAXIMUM EXTENT PERMITTED BY APPLICABLE LAW, NO LIABILITY IS ASSUMED FOR EXPENSES OR DAMAGES RESULTING FROM INTERRUPTION IN OPERATION OF EQUIPMENT, OR FOR INCIDENTAL, DIRECT, OR CONSEQUENTIAL DAMAGES OF ANY NATURE.**

In the event that there is a defect in materials or workmanship of a Da-Lite product, you may contact Customer Care at 3100 North Detroit Street, Warsaw, IN 46582, (866) 977-3901.

IMPORTANT: THIS WARRANTY SHALL NOT BE VALID AND DA-LITE BRANDED PRODUCTS SHALL NOT BE BOUND BY THIS WARRANTY IF THE PRODUCT IS NOT OPERATED IN ACCORDANCE WITH THE DA-LITE WRITTEN INSTRUCTIONS.

Keep your sales receipt to prove the date of purchase and your original ownership.

DA-LITE
A brand of **legrand**



Advantage[®]

(Over 14' W with Closure Door)

USER MANUAL

200163 Rev D

ORIGINAL INSTRUCTIONS

DISCLAIMER

Legrand AV Inc. and its affiliated companies and subsidiaries (collectively, "Legrand AV"), intend to make this manual accurate and complete. However, Legrand AV makes no claim that the information contained herein covers all details, conditions or variations, nor does it provide for every possible contingency in connection with the installation or use of the products described herein. The content herein is subject to change without notice or obligation of any kind. To the maximum extent permitted by applicable law, Legrand AV makes no representation or warranty, expressed or implied, regarding the information contained herein. Furthermore, Legrand AV assumes no responsibility for accuracy, completeness or sufficiency of the information contained in this document.

Da-Lite® is a registered trademark of Legrand AV. All rights reserved.

IMPORTANT SAFETY INSTRUCTIONS

When using your video equipment, basic safety precautions should always be followed, including the following:

1. Read and understand all instructions before using.
2. Close supervision is necessary when any appliance is used by or near children. Do not leave appliance unattended while in use.
3. Do not operate appliance with a damaged cord or if the appliance has been dropped or damaged – until it has been examined by a qualified serviceman.
4. Position the cord so that it will not be tripped over, pulled, or contact hot surfaces.
5. If an extension cord is necessary, a cord with a current rating at least equal to that of the appliance should be used. Cords rated for less amperage than the appliance may overheat.
6. To reduce the risk of electric shock, do not immerse this appliance in water or other liquids.
7. To reduce the risk of electric shock, do not disassemble this appliance. Contact an authorized service dealer when repair work is required. Incorrect reassembly can cause electric shock when the appliance is used subsequently.
8. The use of an accessory attachment not recommended by the manufacturer may cause a risk of fire, electric shock, or injury to persons.
9. Failure to provide adequate structural strength for this component can result in serious personal injury or damage to equipment! It is the installer's responsibility to make sure the structure to which this component is attached can support the weight of all equipment. Reinforce the structure as required before installing the component.
10. Use this projection screen only for its intended use as described in these instructions. Do not use attachments not recommended by the manufacturer.

Save These Instructions

TOOLS REQUIRED FOR INSTALLATION

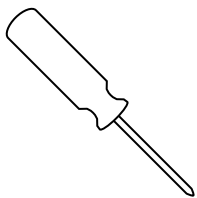

#2 Phillips Screwdriver

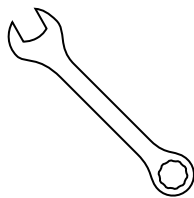

3/4" Open Wrench
or Socket Driver

PRE-INSTALLATION

1. Carefully unpack case from shipping crate.
2. Set aside the Installation Kit. Items inside will be used during installation.
3. Make sure to recheck measurement of case for proper installation clearance.
4. Remove any protective foam from case.
5. If necessary, adjust hanger brackets with a 3/4" open wrench or socket driver.

Ironing Board

The Advantage (Over 14' W with Closure Door) includes an ironing board to flatten the fabric (long strip attached). The ironing board is part of the screen case. Do not remove. Contact Da-Lite if the ironing board is in need of adjustment. (Figure 1).

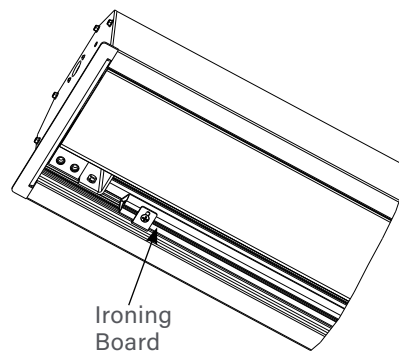

Figure 1

CASE INSTALLATION

The case has a self-trimming flange around the bottom. Ceiling tiles or drywall may be placed on top of this flange to provide a finished appearance.

1. The case provides multiple attachment points for bolts, cables, or threaded rod. Page 5 shows threaded rod installed. The variable position-mounting bracket may be located anywhere along the length of the case. It is recommended to keep the brackets spaced evenly enough to distribute the weight of the screen. One mounting bracket is required for every 4' of case length.
2. Tighten bolts until trim flange is flush with ceiling.
NOTE: For proper operation, screen assembly must be level after installation.
3. Remove 2 screws to open junction box. Install electrical connections that apply to your unit. Make sure to review the wiring diagram for proper hook up. Replace junction box cover and secure with 2 screws.

NOTE: Motor Operator Projection Screen Models LADT, LADDT, LAD and LADD must be installed in accordance with the requirements of the Local Building Codes, the Canadian Electrical Code (CEC), CAN/CSA C22.1 and the National Electric Code (NEC), NFPA 70. An appropriate disconnect device shall be provided as part of the building installation.

If your case was ordered in advance of the screen and roller assembly, your installation is now complete. Continue to step 4 if your Advantage (Over 14' W with Closure Door) was ordered as a complete unit.

4. Carefully remove paper and tape from roller assembly

⚠ Caution! Do not use a knife or sharp object to cut tape; you will damage the screen. Pull orange string.

⚠ ATTENTION! Ne coupez pas le ruban adhésif sur la toile avec un couteau ou un outil tranchant. Tirez sur le cordon orange.

5. Test installation by running screen up and down a few times. Be prepared to stop screen should any objects obstruct the movement of the screen. To prevent damage to the motor, the standard duty cycle is 1 minute on and 3 minutes off.

INSTALLATION

Screens Up to 16' Wide

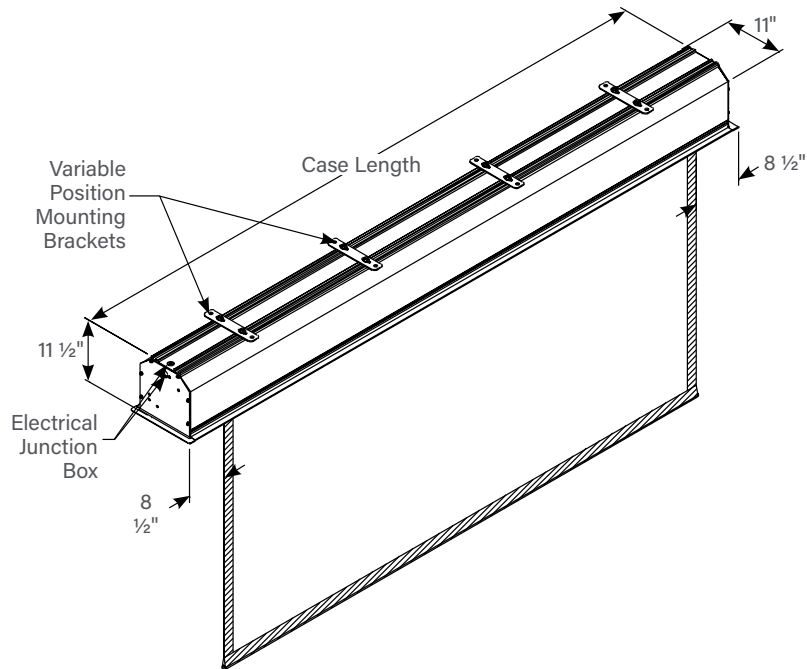
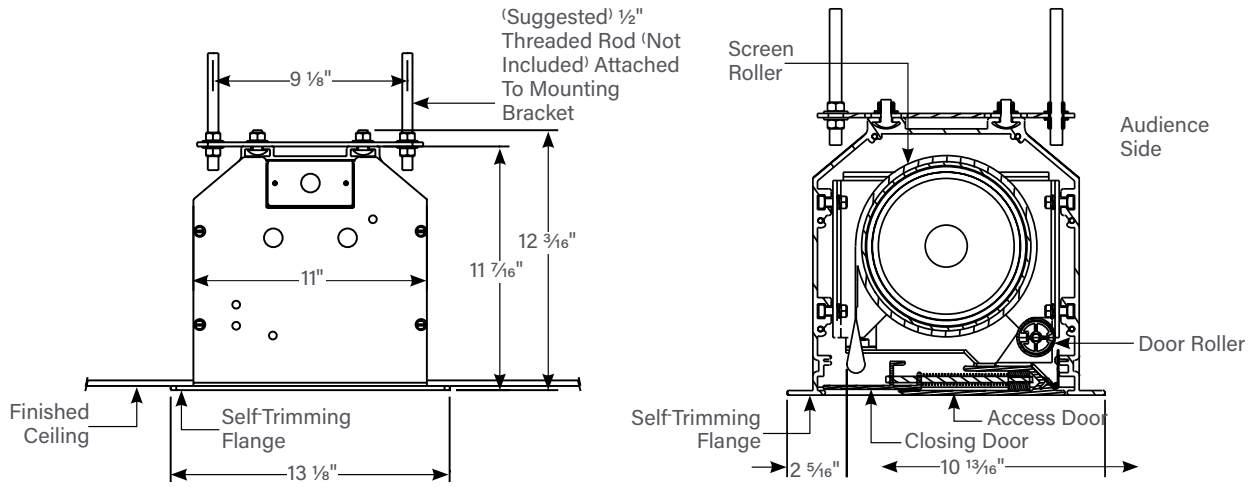

INSTALLATION

Screens 18' and Wider

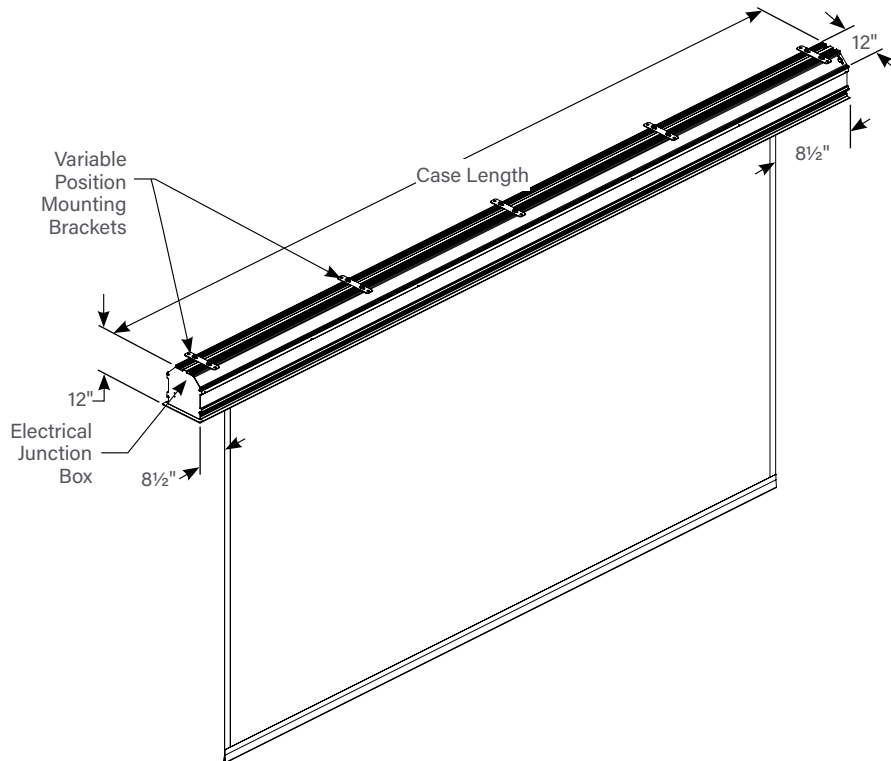
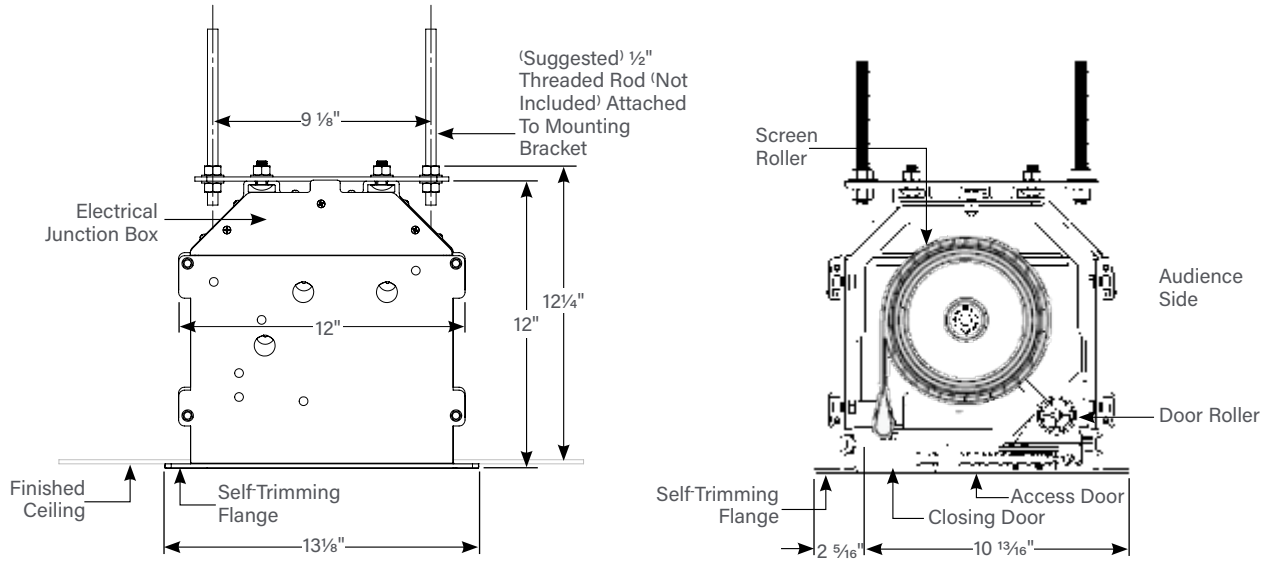

SCREEN AND ROLLER ASSEMBLY INSTALLATION

If your screen was shipped with the motor and roller already installed proceed to step 9.

1. Remove four bolts from ends of door assembly (2 bolts on each end) (Fig. 2). This will allow the door assembly to drop open for access to case. For larger sizes, you will also need to remove the door support screws.
2. Carefully unpack screen and roller assembly. Leave packing paper on the roller.
3. Remove the square peg bracket from the motor end of the roller assembly.
4. Remove the safety clip from the motor attachment bracket located in the motor end of the screen housing.
5. Place the roller assembly into the case with the motor on the left side. The limit switches should be facing down. Line up the head of the motor with the motor attachment bracket.
6. Loosen four bolts that secure pin end mounting bracket into housing. Lift pin end of roller into position and slide the bracket into the roller pin. Tighten all four bolts.
7. Complete electrical hook-up by snapping motor 1/3 wire connectors into case connectors.
8. Return to motor end and insert safety clip over casting bracket to secure motor end.

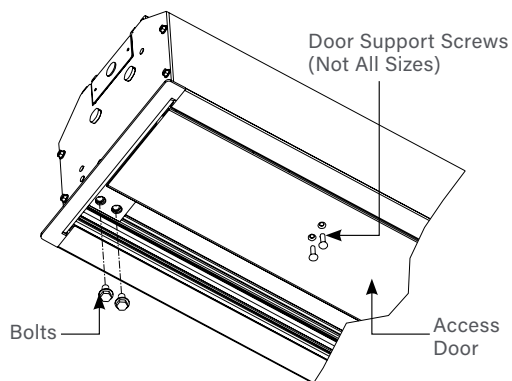

Figure 2

⚠ CAUTION! Do not cut tape on fabric with a knife or any sharp tool. Remove by hand.

⚠ ATTENTION! Ne coupez pas le ruban adhésif sur la toile avec un couteau ou un outil tranchant. Retirez à la main.

9. Carefully remove tape strips securing picture surface around roller. Slat should move freely (Fig. 3). (Only if the roller assembly is pre installed).
10. Test installation by operating the screen several times. Be prepared to stop the screen. The door assembly will not close until the wall switch is placed in the up position and when the screen motor stops at its limit switch in the up direction.

NOTE: Unit duty cycle is 1 minute on, 3 minutes off.

NOTE: Excessive continuous operation may cause the motor to overheat. If this happens the motor will shut off until it cools to a normal operating temperature.
11. Close door assembly and replace four bolts at ends of door (2 bolts on each end) (Fig. 2).

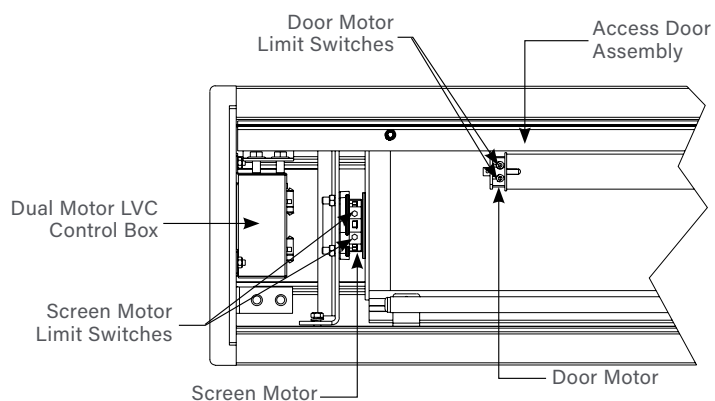

Figure 3

SCREEN ADJUSTMENT

Surface travel is stopped automatically in the fully opened and closed positions by limit switches that are properly adjusted at Da-Lite. Should it be necessary to adjust for more or less drop of picture, proceed in the following manner:

NOTE: Use a screw driver or 5/32" Allen wrench to make adjustments.

More Screen Drop

1. Place operating switch in **"down"** position.
2. When the screen stops, turn the white **"down"** limit knob (Fig. 3) one-quarter turn counterclockwise. Test by raising picture surface approximately two feet, then lower again. Repeat until desired picture surface position is attained.

▲ CAUTION: Do not adjust for more drop than what was ordered. At least 1-1/2 wraps of fabric must remain on the roller. This screen comes standard with 0" or 2" black at the top. See the specification data sheet for details.

▲ ATTENTION! N'effectuez pas de réglage pour obtenir un déroulement supérieur à celui commandé. Au moins 1 à 1/2 tour de toile doit être maintenu sur le cylindre. Cet écran est doté de série d'une bande noire supérieure de 0 cm (0 po) ou 5 cm (2 po). Consultez la fiche technique pour plus de renseignements.

Less Screen Drop

1. Raise picture surface approximately two feet above desired level.
2. Place operating switch in **"off"** position.
3. Turn the white **"down"** limit switch (Fig. 2) one-quarter turn clockwise. Test by raising picture surface approximately two feet, then lower again. Repeat until desired picture surface position is attained.

Contact Da-Lite at 800-622-3737 if door motor needs adjustment.

WIRING DIAGRAM

120V Wiring Diagram

NOTE: Electrical connections on left end of case.

Use provided knockouts for all electrical connections.
DO NOT drill additional holes into screen case or end cap.

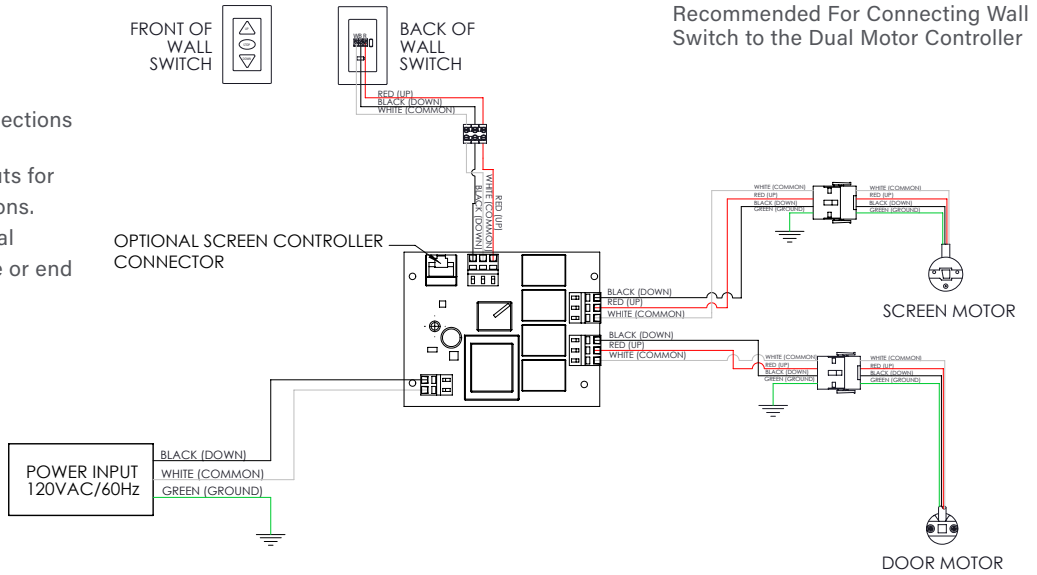

230V Wiring Diagram

NOTE: Electrical connections on left end of case.

Use provided knockouts for all electrical connections.
DO NOT drill additional holes into screen case or end cap.

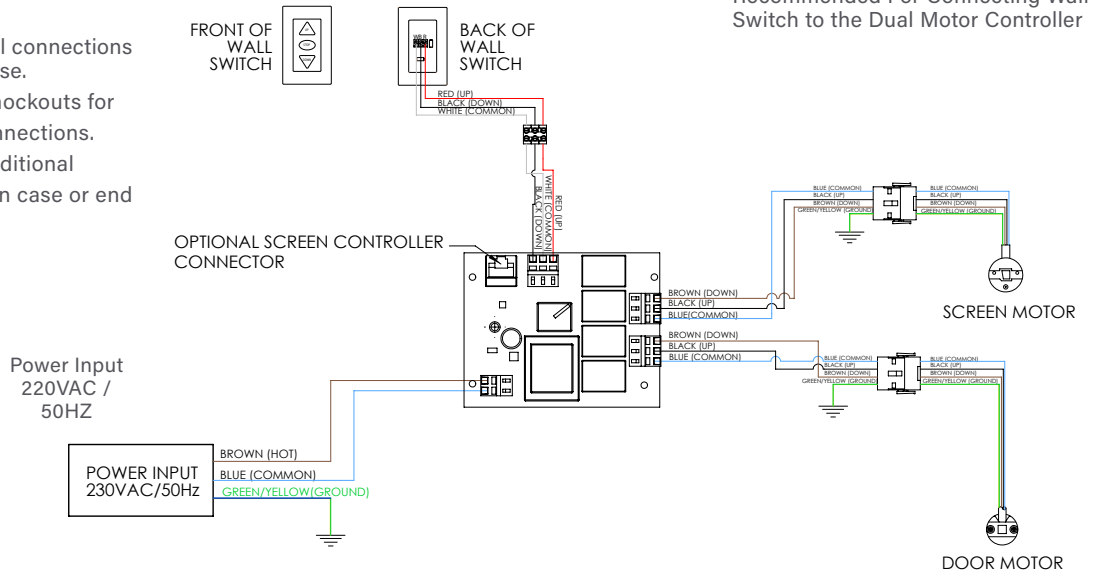

TROUBLESHOOTING

SYMPTOM	CAUSE	SOLUTION
Screen will not operate or will not go "down." Motor does not hum.	Incorrect line voltage.	Verify 115-125V (or 220-240V). If insufficient voltage, rewire incoming electric line.
	Blown facility fuse.	Replace facility fuse.
	Tripped facility circuit breaker.	Reset facility circuit breaker.
	No power to operating switch or junction box.	Check above. Tighten all loose wire connections. Recheck wiring. See installation instructions.
	Low voltage board has no power or blown transformer.	Replace low voltage board. "Down" Position Check for power across black and white leads.
	Power at junction box. Thermal overload tripped.	Let motor cool down for 15 minutes. Try again.
	Broken wire in the "down" position.	Check for continuity.
	Defective motor, limit switch or capacitor.	Replace motor assembly. NOTE: Motor is a sealed assembly.
Motor hums.	Capacitor burned out.	Replace motor assembly.
Screen will not move upward. Motor does not hum.	Incorrect line voltage.	Verify 115-125V (or 220-240V). If insufficient voltage, rewire incoming electric line.
	Blown facility fuse.	Replace facility fuse.
	Tripped facility circuit breaker.	Reset facility circuit breaker.
	No power to operating switch or junction box.	Check above. Tighten all loose wire connections. See above.
	Low voltage board has no power or blown transformer.	Replace low voltage board. "Up" Position Check for power across red and white leads.
	Open door limit switch.	Replace switch.
	Power at junction box. Thermal overload tripped.	Let motor cool down for 15 minutes. Try again.
	Broken wire in the "up" position.	Check for continuity.
	Defective motor, limit switch or capacitor.	Replace motor assembly. NOTE: Motor is a sealed assembly.
Motor hums.	Capacitor burned out.	Replace motor assembly.

TROUBLESHOOTING (CONT.)

SYMPTOM	CAUSE	SOLUTION
Door will not open.	Spring has an obstruction not allowing door to open.	Check installation to free door. Clear any foreign substance from spring.
	No power.	See above.
Door does not close.	Mis-adjusted door motor limit.	Adjust door motor limit. Call Da-Lite for instruction.
	Low voltage board has no power or a blown transformer.	Replace low voltage board.
"Down" limit switch incorrect.	"Down" limit switch out of adjustment.	See installation instructions.
Noise. NOTE: Screen will operate with a low-pitched hum.	Buzzing noise.	Adjust door limit switch (too far down).
	Gear noise.	Replace motor assembly.
Fabric rubbing.	Normal condition. NOTE: Screens with ironing boards have fabric that drags across the board.	
Coasting.	Defective brake.	Replace motor assembly.
Roller displaced from mounting bracket.	Pin end slipped out of nylon bearing.	Realign pin end bracket.
Fabric hangs crooked.	Screen not installed properly.	Check for level and plumb.
	Fabric is damaged.	Replace fabric.
Door closes before screen is all the way up.	Screen "up" limit out of adjustment.	Adjust "up" limit (call factory for instructions).
Door opens but screen does not operate.	Loose wire.	Check all wiring and connections.

CONDITIONS FOR TRANSPORTATION AND STORAGE

- Temperature: Between 40 - 100°F (5 - 40°C)
- Relative Humidity: 30% to 70%, non-condensing
- Always keep the projection screen horizontal during transport and storage
- Make sure the entire package is supported when stored
- Do not stack more than six projection screens on top of each other
- Make sure the heaviest package is placed at the bottom of the stack

Screen surface should be allowed to air out once every two months, or otherwise used on a regular basis, if the temperature is above 72°F (22°C) and at least once every month if the temperature goes above 85°F (30°C).

LIMITED FIVE-YEAR WARRANTY ON DA-LITE PRESENTATION PRODUCTS

Legrand AV Inc. warrants certain Da-Lite branded products to the original purchaser only, to be free from defects in materials and workmanship for a period of five (5) years from the date of purchase by the original purchaser; provided they are properly operated according to Da-Lite's instructions and are not damaged due to improper handling or treatment after shipment from the factory.

Limited five-year warranty applies to the following products:

Wireline Advantage®, Tensioned Advantage Series, Advantage Series, Tensioned Professional, Professional, Tensioned Contour®, Contour, Tensioned Cosmopolitan® Series, Cosmopolitan Series, Tensioned Designer Contour, Designer Contour, Studio, Arena, Parallax®, Parallax Thin, FullVision, UTB Contour, Cinema Contour, Da-Snap, IDEA™ Screen, IDEA Panoramic, Fast-Fold® Deluxe, Fast-Fold Deluxe Drapery Kits, Da-Plex, and Rear Projection Mirror System.

This warranty does not apply to equipment showing evidence of misuse, abuse or accidental damage, or which has been tampered with or repaired by a person other than authorized Da-Lite personnel.

Da-Lite's sole obligation under this warranty shall be to repair or to replace (at Da-Lite's option) the defective part of the merchandise. Returns for service should be made to your Da-Lite dealer. If it is necessary for the dealer to return the screen or part to Da-Lite, transportation expenses to and from Da-Lite are payable by the purchaser and Da-Lite is not responsible for damage in shipment. To protect yourself against damage or loss in transit, insure the product and prepay all transportation expenses.

TO THE MAXIMUM EXTENT PERMITTED BY APPLICABLE LAW, THIS WARRANTY IS IN LIEU OF ALL OTHER WARRANTIES, EXPRESS OR IMPLIED, INCLUDING WARRANTIES AS TO FITNESS FOR USE AND MERCHANTABILITY. Any implied warranties of fitness for use, or merchantability, that may be mandated by statute or rule of law are limited to the five (5) year warranty period. This warranty gives you specific legal rights, and you may also have other rights, which vary from state-to-state. **TO THE MAXIMUM EXTENT PERMITTED BY APPLICABLE LAW, NO LIABILITY IS ASSUMED FOR EXPENSES OR DAMAGES RESULTING FROM INTERRUPTION IN OPERATION OF EQUIPMENT, OR FOR INCIDENTAL, DIRECT, OR CONSEQUENTIAL DAMAGES OF ANY NATURE.**

In the event that there is a defect in materials or workmanship of a Da-Lite product, you may contact Customer Care at 3100 North Detroit Street, Warsaw, IN 46582, (866) 977-3901.

IMPORTANT: THIS WARRANTY SHALL NOT BE VALID AND DA-LITE BRANDED PRODUCTS SHALL NOT BE BOUND BY THIS WARRANTY IF THE PRODUCT IS NOT OPERATED IN ACCORDANCE WITH THE DA-LITE WRITTEN INSTRUCTIONS.

Keep your sales receipt to prove the date of purchase and your original ownership.

DA-LITE
A brand of  **legrand**



Advantage[®]

(Over 16' W)

USER MANUAL

200158 Rev D

ORIGINAL INSTRUCTIONS

DISCLAIMER

Legrand AV Inc. and its affiliated companies and subsidiaries (collectively, "Legrand AV"), intend to make this manual accurate and complete. However, Legrand AV makes no claim that the information contained herein covers all details, conditions or variations, nor does it provide for every possible contingency in connection with the installation or use of the products described herein. The content herein is subject to change without notice or obligation of any kind. To the maximum extent permitted by applicable law, Legrand AV makes no representation or warranty, expressed or implied, regarding the information contained herein. Furthermore, Legrand AV assumes no responsibility for accuracy, completeness or sufficiency of the information contained in this document.

Da-Lite® is a registered trademark of Legrand AV. All rights reserved.

IMPORTANT SAFETY INSTRUCTIONS

When using your video equipment, basic safety precautions should always be followed, including the following:

1. Read and understand all instructions before using.
2. Position the cord so that it will not be tripped over, pulled, or contact hot surfaces.
3. If an extension cord is necessary, a cord with a current rating at least equal to that of the appliance should be used. Cords rated for less amperage than the appliance may overheat.
4. To reduce the risk of electric shock, do not disassemble this appliance. Contact an authorized service dealer when repair work is required. Incorrect reassembly can cause electric shock when the appliance is used subsequently.
5. The use of an accessory attachment not recommended by the manufacturer may cause a risk of fire, electric shock, or injury to persons.
6. Failure to provide adequate structural strength for this component can result in serious personal injury or damage to equipment! It is the installer's responsibility to make sure the structure to which this component is attached can support the weight of all equipment. Reinforce the structure as required before installing the component.
7. Use this projection screen only for its intended use as described in these instructions. Do not use attachments not recommended by the manufacturer.

Save These Instructions

TOOLS REQUIRED FOR INSTALLATION

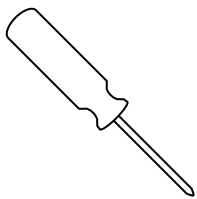

#2 Phillips Screwdriver

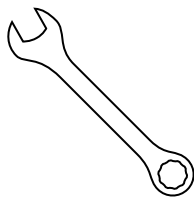

3/4" Open Wrench
or Socket Driver

PRE-INSTALLATION

1. Carefully unpack case from shipping crate.
2. Set aside the Installation Kit. Items inside will be used during installation.
3. Make sure to recheck measurement of case for proper installation clearance.
4. Remove any protective foam from case.
5. If necessary, adjust hanger brackets with a 3/4" open wrench or socket driver.

Ironing Board

The Advantage (Over 14' W) includes an ironing board to flatten the fabric (long strip attached). The ironing board is part of the screen case. Do not remove. Contact Da-Lite if the ironing board is in need of adjustment. (Figure 1).

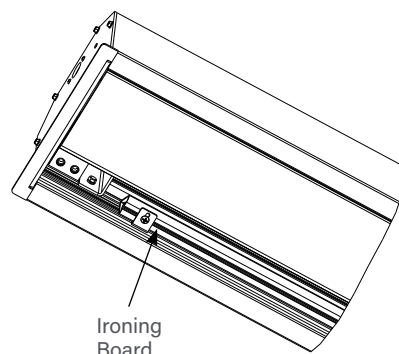

Figure 1

CASE INSTALLATION

The case has a self-trimming flange around the bottom. Ceiling tiles or drywall may be placed on top of this flange to provide a finished appearance.

1. The case provides multiple attachment points for bolts, cables, or threaded rod. Page 5 shows threaded rod installed. The variable position-mounting bracket may be located anywhere along the length of the case. It is recommended to keep the brackets spaced evenly enough to distribute the weight of the screen. One mounting bracket is required for every 4' of case length.

2. Tighten bolts until trim flange is flush with ceiling.

NOTE: For proper operation, screen assembly must be level after installation.

3. Remove 2 screws to open junction box. Install electrical connections that apply to your unit. Make sure to review the wiring diagram for proper hook up. Replace junction box cover and secure with 2 screws.

NOTE: Please Note: Motor Operator Projection Screen Models LADT, LADDT, LAD and LADD must be installed in accordance with the requirements of the Local Building Codes, the Canadian Electrical Code (CEC), CAN/CSA C22.1 and the National Electric Code (NEC), NFPA 70. An appropriate disconnect device shall be provided as part of the building installation.

If your case was ordered in advance of the screen and roller assembly, your installation is now complete. Continue to step 4 if your Advantage (Over 14' W) was ordered as a complete unit.

4. Carefully remove paper and tape from roller assembly

⚠ Caution! Do not use a knife or sharp object to cut tape; you will damage the screen. Pull orange string.

⚠ ATTENTION! Ne coupez pas le ruban adhésif sur la toile avec un couteau ou un outil tranchant. Tirez sur le cordon orange.

5. Test installation by running screen up and down a few times. Be prepared to stop screen should any objects obstruct the movement of the screen. To prevent damage to the motor, the standard duty cycle is 1 minute on and 3 minutes off.

INSTALLATION

Screens Up to 16' Wide*

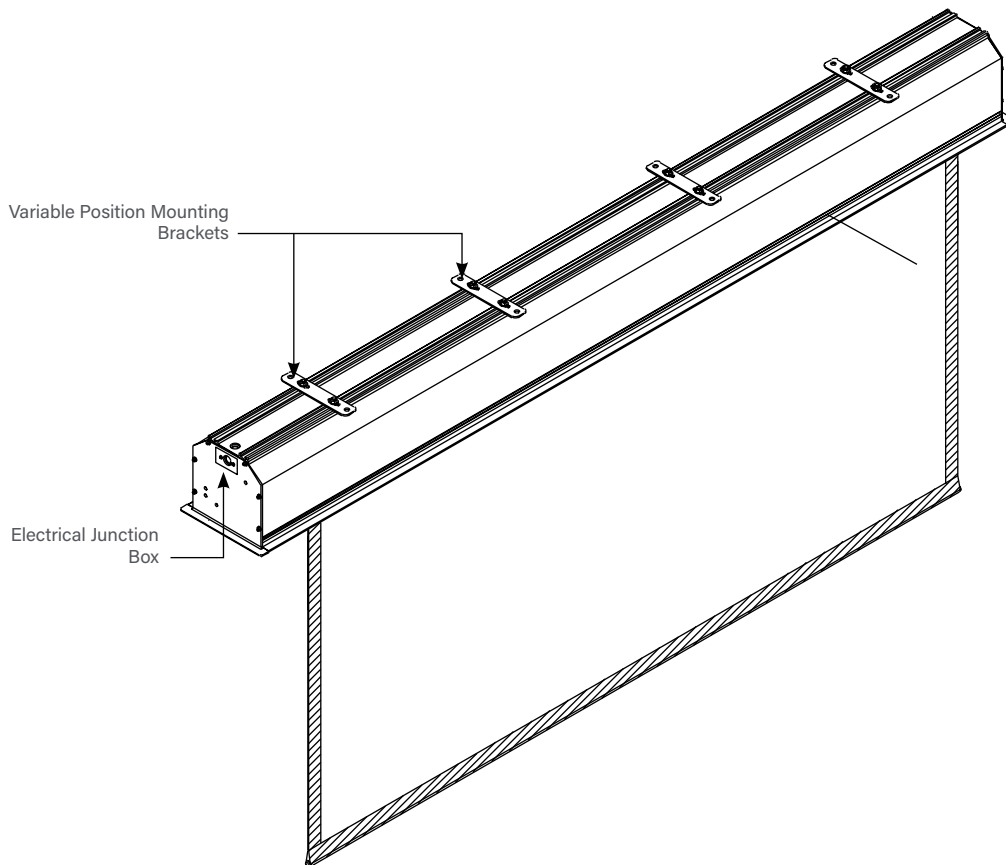
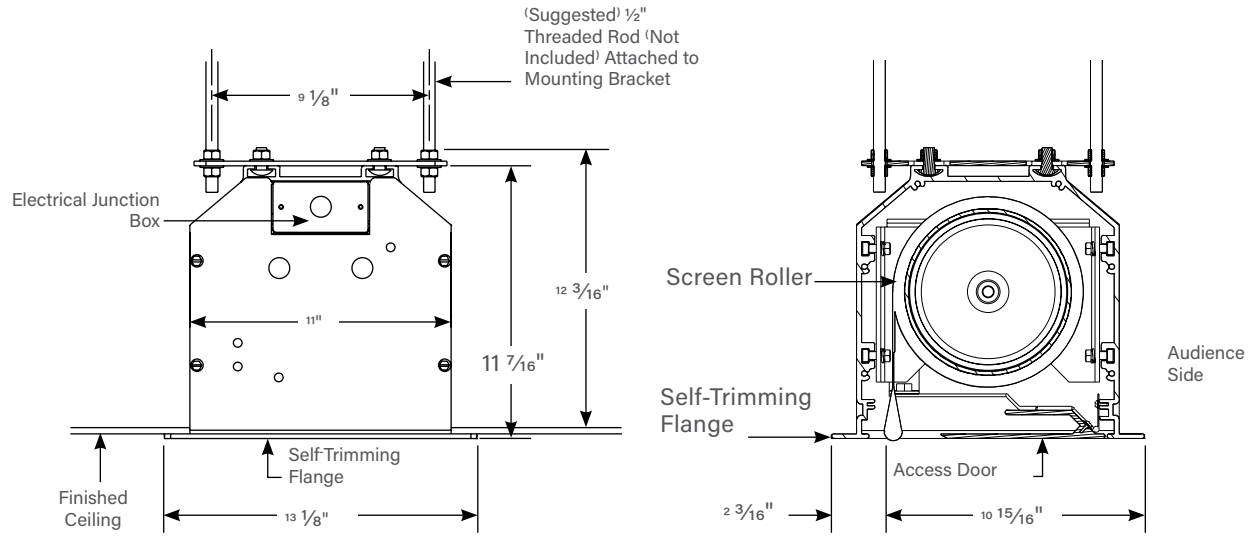

*Custom sizes only. All standard sizes are 18' and wider (see next page).

INSTALLATION

Screens 18' and Wider

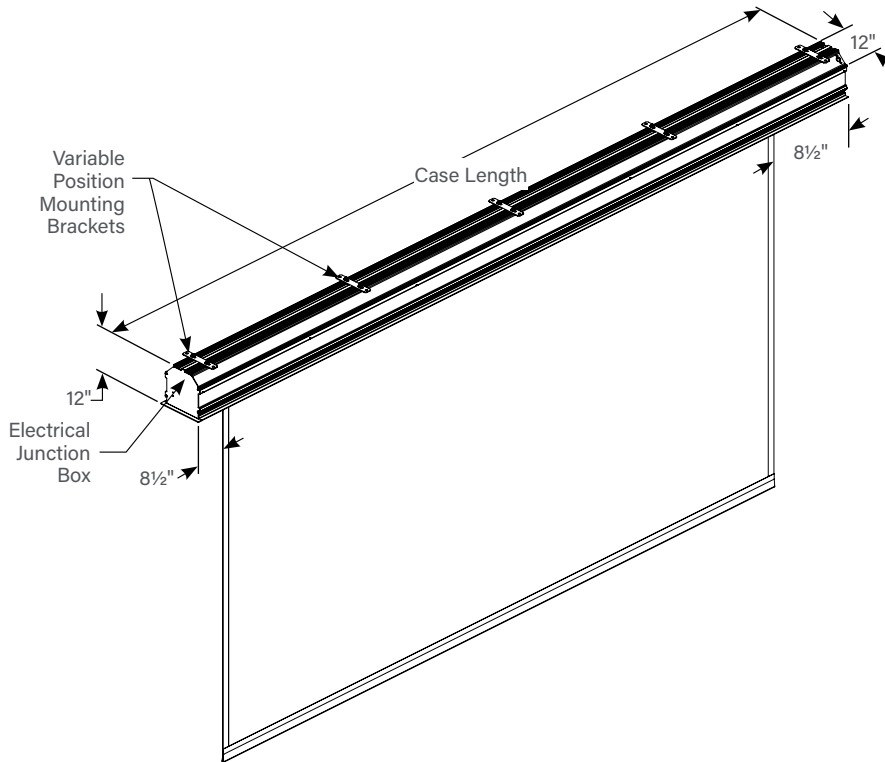
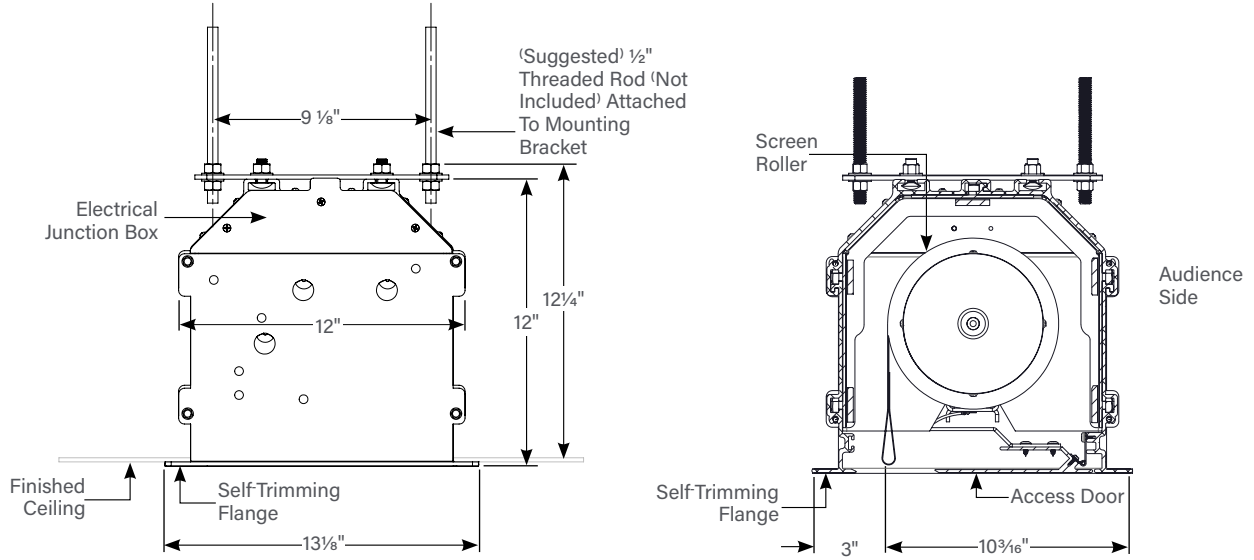

SCREEN AND ROLLER ASSEMBLY INSTALLATION

Tools required for screen and roller assembly:



If your screen was shipped with the motor and roller already installed proceed to step 7.

1. Remove the access door. First, remove the 2 bolts from each end with a 9/16" open wrench or socket driver. Next, use a 5/32" hex key to remove the two screws in the center of the access door. This will allow the door to drop open on the hinges (Figure 2).
 2. Carefully unpack screen and roller assembly. Leave packing paper on the roller.
 3. Remove the square peg bracket from the motor end of the roller assembly (Figure 3).
 4. Remove the safety clip from the motor attachment bracket located in the motor end of the screen housing.
 5. Use a 1/2" open wrench or socket driver to loosen the four bolts that secure pin end mounting bracket into housing. Lift pin end of roller into position and slide the bracket into the roller pin. Tighten all four bolts. Slide the pin end bracket towards the end of the case (Figure 4).
 6. Place the roller assembly into the case with the motor on the left side. The limit switches should be facing down. Line up the head of the motor with the motor attachment bracket.
 7. Complete electrical hook-up by snapping motor 1/3 wire connectors into case connectors (Figure 3).
 8. Return to motor end and insert safety clip over casting bracket to secure motor end.
 9. Carefully remove tape strips securing picture surface around roller. Slat should move freely. (Only if the roller assembly is pre installed.)
- ⚠ CAUTION! Do not cut tape on fabric with a knife or any sharp tool. Remove by hand.**
- ⚠ ATTENTION! Ne coupez pas le ruban adhésif sur la toile avec un couteau ou un outil tranchant. Retirez à la main.**
10. Test installation by running screen up and down a few times. Be prepared to stop screen should any objects obstruct the movement of the screen. To prevent damage to the motor, the standard duty cycle is 1 minute on and 3 minutes off.
 11. Re-install the access door. Procedure is the reverse of step 1 listed above.

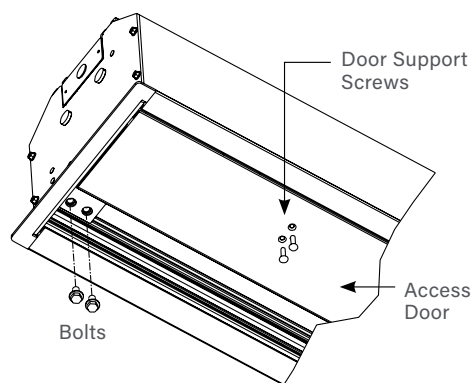

Figure 2

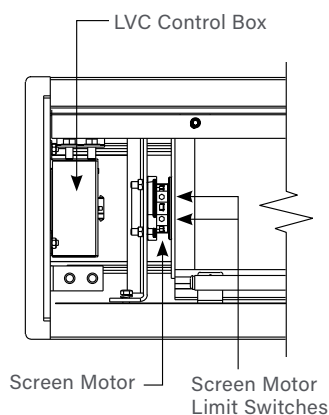

Figure 3

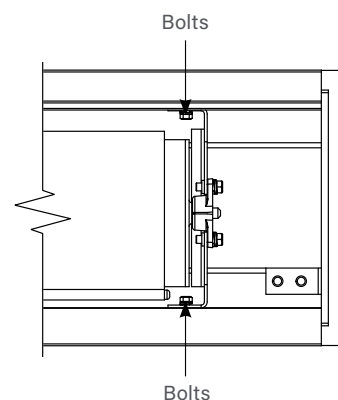

Figure 4

SCREEN ADJUSTMENT

Surface travel is stopped automatically in the fully opened and closed positions by limit switches that are properly adjusted at Da-Lite. Should it be necessary to adjust for more or less drop of picture, proceed in the following manner:

NOTE: Use a screw driver or 5/32" Allen wrench to make adjustments.

More Screen Drop

1. Place operating switch in "down" position.
2. When the screen stops, turn the white "down" limit knob one-quarter turn counterclockwise (Figure 5). Test by raising picture surface approximately two feet, then lower again. Repeat until desired picture surface position is attained.

⚠ CAUTION: Do not adjust for more drop than what was ordered. At least 1-1/2 wraps of fabric must remain on the roller. This screen comes standard with 0" or 2" black at the top. See the specification data sheet for details.

⚠ ATTENTION! N'effectuez pas de réglage pour obtenir un déroulement supérieur à celui commandé. Au moins 1 à 1/2 tour de toile doit être maintenu sur le cylindre. Cet écran est doté de série d'une bande noire supérieure de 0 cm (0 po) ou 5 cm (2 po). Consultez la fiche technique pour plus de renseignements.

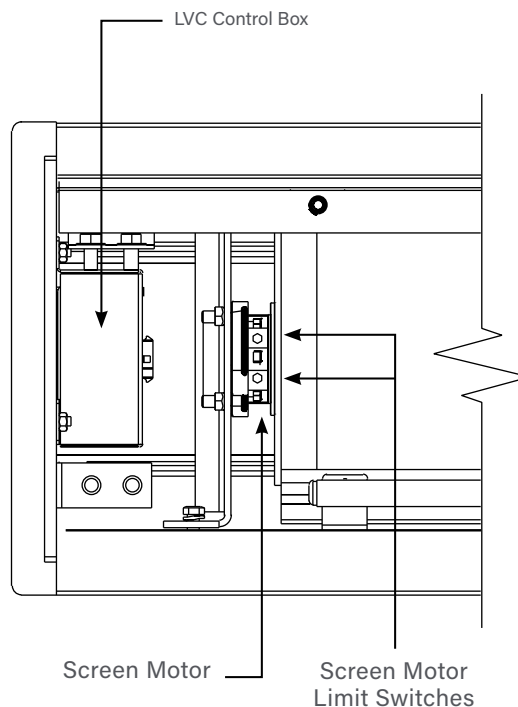

Figure 5

Less Screen Drop

1. Raise picture surface approximately two feet above desired level.
2. Place operating switch in "off" position.
3. Turn the white "down" limit switch one-quarter turn clockwise (Figure 5). Test by raising picture surface approximately two feet, then lower again. Repeat until desired picture surface position is attained.

120V WIRING DIAGRAM

NOTE: 20-24 AWG wire recommended for connecting wall switch to low voltage controller.

- ⚠ CAUTION:** Do not use 3-position high voltage rocker switch with this unit! This will damage the low voltage control board.
- ⚠ ATTENTION:** N'utilisez pas un interrupteur à bascule à 3 positions pour circuit à haute tension avec cette unité. Cela endommagera le tableau de contrôle basse tension.

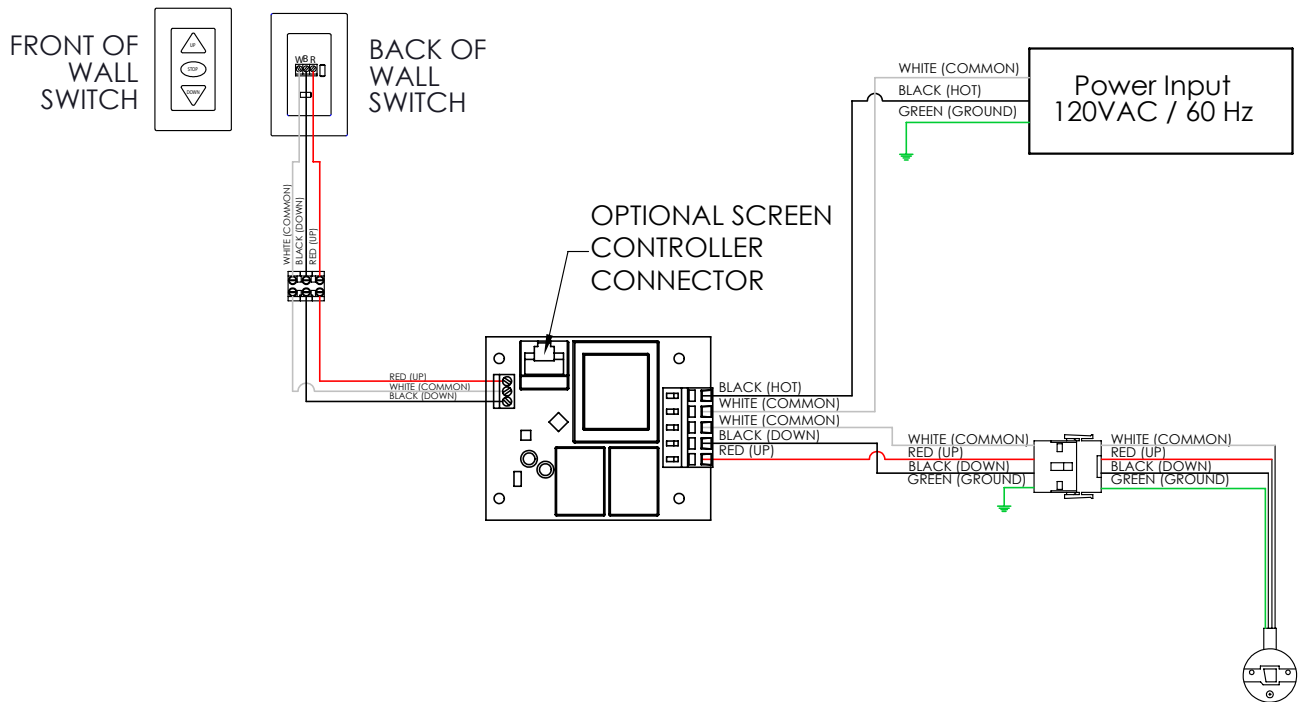

230V WIRING DIAGRAM

NOTE: 20-24 AWG wire recommended for connecting wall switch to low voltage controller.

- ⚠ CAUTION:** Do not use 3-position high voltage rocker switch with this unit! This will damage the low voltage control board.
- ⚠ ATTENTION:** N'utilisez pas un interrupteur à bascule à 3 positions pour circuit à haute tension avec cette unité. Cela endommagera le tableau de contrôle basse tension.

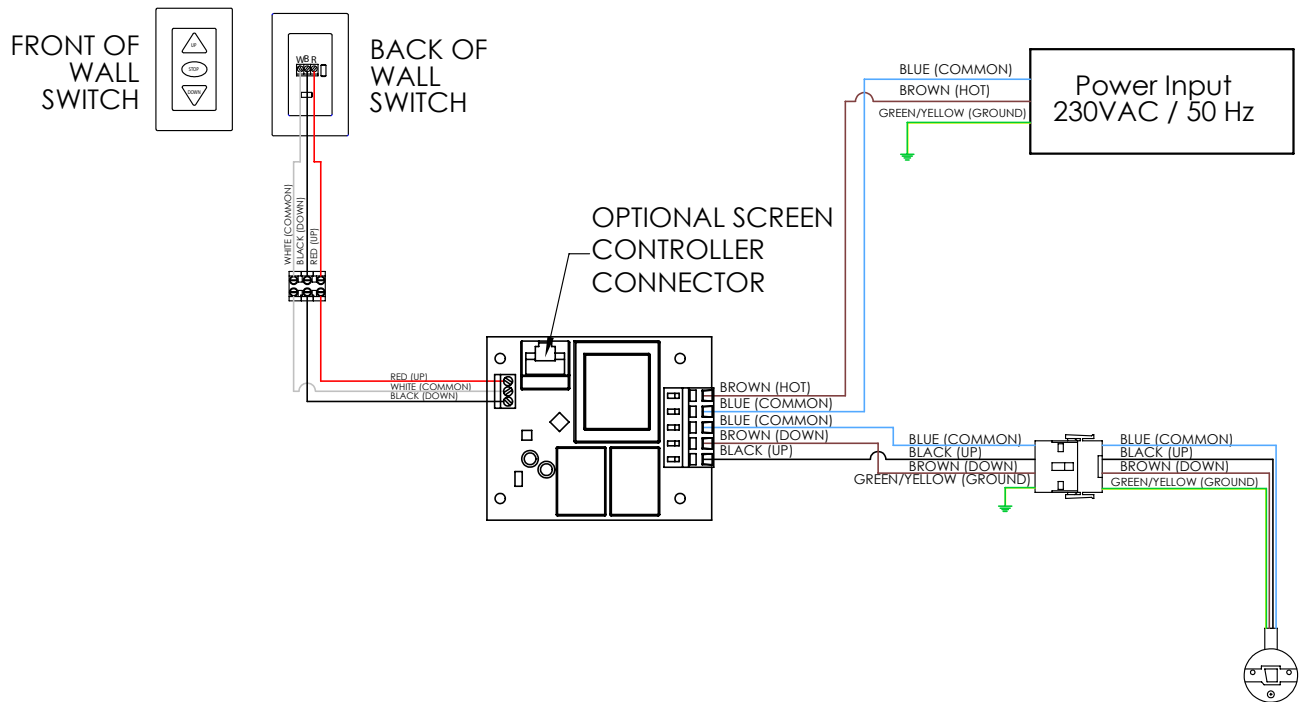

TROUBLESHOOTING

SYMPTOM	CAUSE	SOLUTION
Screen will not operate and motor does not hum.	Incorrect line voltage.	Verify 115-125V (or 220-240V). If insufficient voltage, rewire incoming electric line.
	Blown fuse.	Replace fuse.
	Tripped circuit breaker.	Reset circuit breaker.
	No power to operating switch or junction.	Check above. Tighten all loose wire connections. Correct any improper connections. Down Position Check for power across black and white leads. Up Position Check for power across red and white leads.
Screen will not operate and motor does not hum. Power at junction box.	Thermal overload tripped.	Let motor cool down for 15 minutes. Try again.
	Broken wire in the "down" or "up" position.	Check for continuity. Cut off old splice and reconnect.
	Defective motor, limit switch or capacitor.	Replace motor assembly. NOTE: Motor is a sealed assembly.
	Capacitor burned out.	Replace motor assembly.
Screen does not stop at correct position.	Limit switch out of adjustment.	See Screen Adjustment section.
Noise. NOTE: Screen will operate with a low pitched hum.	Squeaking, rubber end plug rubbing on motor.	Center roller in case.
	Grinding. Foreign object in screen rubbing on roller or fabric.	Remove.
	Gear noise.	Replace motor assembly.
Fabric rubbing.	Normal condition. NOTE: Screens with ironing boards have fabric that drags across the board.	
Coasting.	Defective brake.	Replace motor assembly.
Fabric hangs crooked.	Screen not installed properly.	Check for level and plumb.
	Fabric has backed up inside case.	Adjust "down" limit switch slowly until roller is exposed and wrinkle comes out, then readjust for proper drop.
	Fabric is damaged.	Replace fabric.

CONDITIONS FOR TRANSPORTATION AND STORAGE

- Temperature: Between 40 - 100°F (5 - 40°C)
- Relative Humidity: 30% to 70%, non-condensing
- Always keep the projection screen horizontal during transport and storage
- Make sure the entire package is supported when stored
- Do not stack more than six projection screens on top of each other
- Make sure the heaviest package is placed at the bottom of the stack

Screen surface should be allowed to air out once every two months, or otherwise used on a regular basis, if the temperature is above 72°F (22°C) and at least once every month if the temperature goes above 85°F (30°C).

LIMITED FIVE-YEAR WARRANTY ON DA-LITE PRESENTATION PRODUCTS

Legrand AV Inc. warrants certain Da-Lite branded products to the original purchaser only, to be free from defects in materials and workmanship for a period of five (5) years from the date of purchase by the original purchaser; provided they are properly operated according to Da-Lite's instructions and are not damaged due to improper handling or treatment after shipment from the factory.

Limited five-year warranty applies to the following products:

Wireline Advantage®, Tensioned Advantage Series, Advantage Series, Tensioned Professional, Professional, Tensioned Contour®, Contour, Tensioned Cosmopolitan® Series, Cosmopolitan Series, Tensioned Designer Contour, Designer Contour, Studio, Arena, Parallax®, Parallax Thin, FullVision, UTB Contour, Cinema Contour, Da-Snap, IDEA™ Screen, IDEA Panoramic, Fast-Fold® Deluxe, Fast-Fold Deluxe Drapery Kits, Da-Plex, and Rear Projection Mirror System.

This warranty does not apply to equipment showing evidence of misuse, abuse or accidental damage, or which has been tampered with or repaired by a person other than authorized Da-Lite personnel.

Da-Lite's sole obligation under this warranty shall be to repair or to replace (at Da-Lite's option) the defective part of the merchandise. Returns for service should be made to your Da-Lite dealer. If it is necessary for the dealer to return the screen or part to Da-Lite, transportation expenses to and from Da-Lite are payable by the purchaser and Da-Lite is not responsible for damage in shipment. To protect yourself against damage or loss in transit, insure the product and prepay all transportation expenses.

TO THE MAXIMUM EXTENT PERMITTED BY APPLICABLE LAW, THIS WARRANTY IS IN LIEU OF ALL OTHER WARRANTIES, EXPRESS OR IMPLIED, INCLUDING WARRANTIES AS TO FITNESS FOR USE AND MERCHANTABILITY.

Any implied warranties of fitness for use, or merchantability, that may be mandated by statute or rule of law are limited to the five (5) year warranty period. This warranty gives you specific legal rights, and you may also have other rights, which vary from state-to-state. **TO THE MAXIMUM EXTENT PERMITTED BY APPLICABLE LAW, NO LIABILITY IS ASSUMED FOR EXPENSES OR DAMAGES RESULTING FROM INTERRUPTION IN OPERATION OF EQUIPMENT, OR FOR INCIDENTAL, DIRECT, OR CONSEQUENTIAL DAMAGES OF ANY NATURE.**

In the event that there is a defect in materials or workmanship of a Da-Lite product, you may contact Customer Care at 3100 North Detroit Street, Warsaw, IN 46582, (866) 977-3901.

IMPORTANT: THIS WARRANTY SHALL NOT BE VALID AND DA-LITE BRANDED PRODUCTS SHALL NOT BE BOUND BY THIS WARRANTY IF THE PRODUCT IS NOT OPERATED IN ACCORDANCE WITH THE DA-LITE WRITTEN INSTRUCTIONS.

Keep your sales receipt to prove the date of purchase and your original ownership.

LEGRAND | AV COMMERCIAL BRANDS

C2G | Chief | Da-Lite | Luxul | Middle Atlantic | Vaddio | Wiremold

FOR YOUR IMAGE | legrandav.com

USA 866.977.3901 av.da-lite.support@legrand.com CANADA 877.345.4329 av.da-lite.support@legrand.com

EMEA +31 495 580 840 av.emea.sales@legrand.com APAC +852 2145 4099 av.asia.sales@legrand.com

©2024 Legrand AV Inc. 230327 Rev D 12/23 Da-Lite is a registered trademark of Legrand AV Inc. All other brand names or marks are used for identification purposes and are trademarks of their respective owners. All patents are protected under existing designations. Other patents pending.