

Model C with CSR

Spring Roller Type Screen with Controlled Screen Return



SPECIFICATION DATA

SUGGESTED SPECIFICATIONS: _____ projection screen(s), _____(H) x _____(W), wall or ceiling mounting type. To have black masking borders standard on flame retardant and mildew resistant fiberglass fabric, mounted on a ball bearing rigid steel spring roller. To be equipped with Controlled Screen Return (CSR) to control the return speed of the screen surface back into the case. Fabric to be permanently attached to roller. To have powder coated white 21-gauge steel case with flat back design. To have

heavy-duty end caps concealing roller ends with steel inner plates to support roller and provide added case strength. End caps shall form sturdy brackets for wall or ceiling installations. Bottom of screen shall be formed into pocket holding tubular metal slat. A 6' pull cord with plastic knob is included. A steel pull bail shall be attached to the slat. Heavy-duty plastic caps shall protect the ends of the slat. Bumper stops shall be built into the case to prevent slat wedging inside case.

HDTV (16:9) Format Dimensions

Viewing Area Sizes (H x W)		Nominal Diagonal		A - Overall Length of Case		B - Between Hanger Eyes		Approx. Ship. Wt.	
In.	Cm	In.	Cm	In.	Cm	In.	Cm	Lbs.	Kg
45" x 80"	114 x 203	92"	234	87 ³ / ₁₆ "	222	85 ¹ / ₁₆ "	218	47	21.3
52" x 92"	132 x 234	106"	269	99 ³ / ₁₆ "	252	97 ¹ / ₁₆ "	248	53	24.0
54" x 96"	137 x 244	110"	279	103 ³ / ₁₆ "	262	101 ¹ / ₁₆ "	258	56	25.4
58" x 104"	147 x 264	119"	302	111 ¹ / ₁₆ "	283	109 ¹ / ₁₆ "	279	61	27.7
65" x 116"	165 x 295	133"	338	123 ³ / ₁₆ "	313	121 ¹ / ₁₆ "	309	67	30.4
78" x 139"	198 x 353	159"	404	147 ³ / ₁₆ "	374	145 ¹ / ₁₆ "	370	73	33.1

(16:10) Wide Format Dimensions

Viewing Area Sizes (H x W)		Nominal Diagonal		A - Overall Length of Case		B - Between Hanger Eyes		Approx. Ship. Wt.	
H x W	Cm	In.	Cm	In.	Cm	In.	Cm	Lbs.	Kg
50" x 80"	127 x 203	94"	239	87 ³ / ₁₆ "	222	85 ¹ / ₁₆ "	218	47	21.3
57 ¹ / ₂ " x 92"	146 x 234	109"	277	99 ³ / ₁₆ "	252	97 ¹ / ₁₆ "	248	57	25.9
60" x 96"	152 x 244	113"	287	103 ³ / ₁₆ "	262	101 ¹ / ₁₆ "	258	59	26.8
65" x 104"	165 x 264	123"	312	111 ¹ / ₁₆ "	283	109 ¹ / ₁₆ "	279	61	27.7
69" x 110"	175 x 279	130"	330	117 ³ / ₁₆ "	298	115 ¹ / ₁₆ "	294	65	29.5
72 ¹ / ₂ " x 116"	184 x 295	137"	348	123 ³ / ₁₆ "	313	121 ¹ / ₁₆ "	309	66	29.9
87" x 139"	221 x 353	164"	417	147 ³ / ₁₆ "	374	145 ¹ / ₁₆ "	370	83	37.6

Video (NTSC 4:3) Format Dimensions

Viewing Area Sizes (H x W)		Nominal Diagonal		A - Overall Length of Case		B - Between Hanger Eyes		Approx. Ship. Wt.	
In.	Cm	In.	Cm	In.	Cm	In.	Cm	Lbs.	Kg
43" x 57"	109 x 145	72"	183	63 ¹ / ₈ "	160	61 ¹ / ₈ "	157	23	10.4
50" x 67"	127 x 170	84"	213	73 ¹ / ₈ "	186	71 ¹ / ₈ "	182	26	11.8
60" x 80"	152 x 203	100"	254	87 ³ / ₁₆ "	222	85 ¹ / ₁₆ "	218	49	22.2
69" x 92"	175 x 234	120"	305	99 ³ / ₁₆ "	252	97 ¹ / ₁₆ "	248	55	24.9
87" x 116"	221 x 295	150"	381	123 ³ / ₁₆ "	313	121 ¹ / ₁₆ "	309	70	31.8
105" x 140"	267 x 356	180"	457	147 ³ / ₁₆ "	374	145 ¹ / ₁₆ "	368	86	39.0
120" x 160"	305 x 406	200"	508	167 ³ / ₁₆ "	425	165 ¹ / ₁₆ "	421	96	43.5

Square Format Dimensions

Sizes (H x W)		A - Overall Length of Case		B - Between Hanger Eyes		Approx. Ship. Wt.	
In.	Cm	In.	Cm	In.	Cm	Lbs.	Kg
60" x 60"	152 x 152	63 ¹ / ₈ "	160	61 ¹ / ₈ "	157	24	10.9
70" x 70"	178 x 178	73 ¹ / ₈ "	186	71 ¹ / ₈ "	182	27	12.2
72" x 72"	183 x 183	75 ¹ / ₈ "	191	73 ¹ / ₈ "	187	31	14.1
84" x 84"	213 x 213	87 ³ / ₁₆ "	222	85 ¹ / ₁₆ "	218	51	23.1
6' x 8'	183 x 244	99 ³ / ₁₆ "	252	97 ¹ / ₁₆ "	248	55	24.9
8' x 8'	244 x 244	99 ³ / ₁₆ "	252	97 ¹ / ₁₆ "	248	57	25.9
7' x 9'	213 x 274	111 ¹ / ₁₆ "	283	109 ¹ / ₁₆ "	279	62	28.1
9' x 9'	274 x 274	111 ¹ / ₁₆ "	283	109 ¹ / ₁₆ "	279	64	29.0
8' x 10'	244 x 305	123 ³ / ₁₆ "	313	121 ¹ / ₁₆ "	309	70	31.8
10' x 10'	305 x 305	123 ³ / ₁₆ "	313	121 ¹ / ₁₆ "	309	70	31.8
9' x 12'	274 x 366	147 ³ / ₁₆ "	374	145 ¹ / ₁₆ "	370	86	39.0
12' x 12'	366 x 366	147 ³ / ₁₆ "	374	145 ¹ / ₁₆ "	370	90	40.8

PRODUCT NOTES

- **Matte White:** Horizontal seam required when both dimensions exceed 10'.
- **High Contrast Matte White:** Available in sizes where both dimensions do not exceed 10'.
- **Video Spectra 1.5:** Available in sizes where both dimensions do not exceed 8'.
- **Silver Lite 2.5:** Available in sizes up to and including 8' x 8'.
- Overall case length dimensions +/- 1/4" (6 mm).
- Detail dimensional drawings and installation instructions available upon request.
- Specifications subject to change without notice.
- Custom formats and sizes available upon request
- **Optional Accessories:** to provide clearance: Furnish heavy extension wall brackets to mount screen 6" from wall. To provide for keystone elimination: Furnish heavy extension wall brackets to mount screen 10" or 14" from wall or furnish heavy adjustable extension wall brackets to mount screen 10", 14", 15 3/4", 18 3/4", 20" or 24" from wall.
- **NOTE:** Brackets also are used for mounting screen across a corner.

WHEN ORDERING, MARK APPROPRIATE SELECTIONS:

1. Select size from charts on the other side.
2. Select viewing surface (All Da-Lite surfaces are GREENGUARD GOLD Certified):
 - Matte White
 - High Contrast Matte White
 - Silver Lite 2.5
 - Video Spectra 1.5
3. Optional accessories:
 - Extra Drop available to lower picture area more than normal. Specify total drop at top ____ (black or white) or at bottom ____ (black or white). 13' maximum total surface height including picture area (12' maximum on 200" Diag.)
 - Pull Rod - 38".
 - No borders (Black masking borders standard)
 - Floating Mounting Bracket (black or white). Recommended for drywall installations.
 - No. 6 Wall Bracket - extends 6" non-adjustable extension brackets (75# maximum per pair) (black or white).
 - Ceiling Trim Kit.
 - Black case (white standard).
 - No. 11 Wall Bracket - 10" or 14" non-adjustable extension brackets (75# maximum per pair) (black or white).
 - No. 23 Adjustable Wall Bracket - extends 10", 14", 15 3/4", 18 3/4", 20" or 24" (75# per pair maximum) (black or white).

PRODUCT VIEW

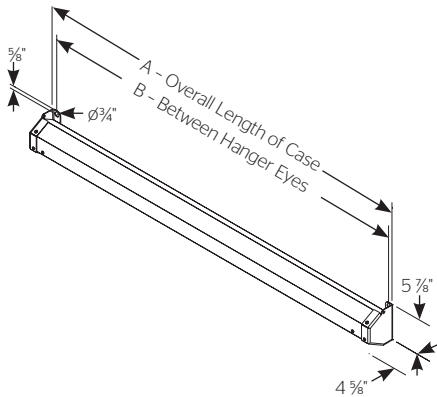

ACCESSORIES

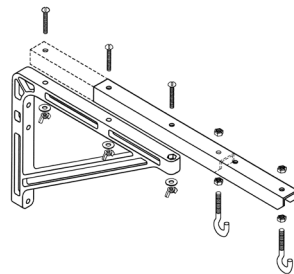

No. 23 Adjustable Wall Bracket
Screen can be extended 10", 14", 15 3/4", 18 3/4", 20" or 24" from wall by wing nut and bolt adjustment.

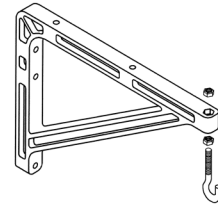

No. 11 Wall Bracket
Screen can be extended 10" or 14" from wall by changing position of bracket.

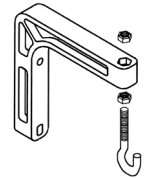

No. 6 Wall Bracket
Screen can be extended 6" from wall.

Extension Wall Brackets (75# Per Pair Maximum)



A Milestone AV Technologies Brand

3100 North Detroit Street
Warsaw, Indiana 46582
P: 574.267.8101 or 800.622.3737
F: 574.267.7804 or 877.325.4832
E: info@da-lite.com
www.da-lite.com

DL-0227 (Rev. 4) 08.15

© 2015 Milestone AV Technologies LLC. Printed in U.S.A.



Pull Rod - 38"
Zinc plated rod with black plastic handle grip allows easy access to screen when mounted out of reach. Also can be used as a pointer.

Project Name: _____

Architect: _____

Contractor: _____ Phone: _____

Reseller: _____ Phone: _____