



INSTRUCTION BOOK FOR
Cosmopolitan Electrol
For Sizes Up To 9' x 12'



Important Safety Instructions

When using your video equipment, basic safety precautions should always be followed, including the following:

1. Read and understand all instructions before using.
2. Position the cord so that it will not be tripped over, pulled, or contact hot surfaces.
3. If an extension cord is necessary, a cord with a current rating at least equal to that of the appliance should be used. Cords rated for less amperage than the appliance may overheat.
4. To reduce the risk of electric shock, do not disassemble this appliance. Contact an authorized service dealer when repair work is required. Incorrect reassembly can cause electric shock when the appliance is used subsequently.
5. The use of an accessory attachment not recommended by the manufacturer may cause a risk of fire, electric shock, or injury to persons.

Pre-Installation

1. Carefully unpack screen and remove outer wrapping from case.
2. Do not remove black tape or rubber bands from slat pocket.
3. Always handle screen in horizontal position.

Installation

There are three methods of mounting to include:

Flush against wall; Suspended from ceiling (use extension brackets); and recessed above ceiling.

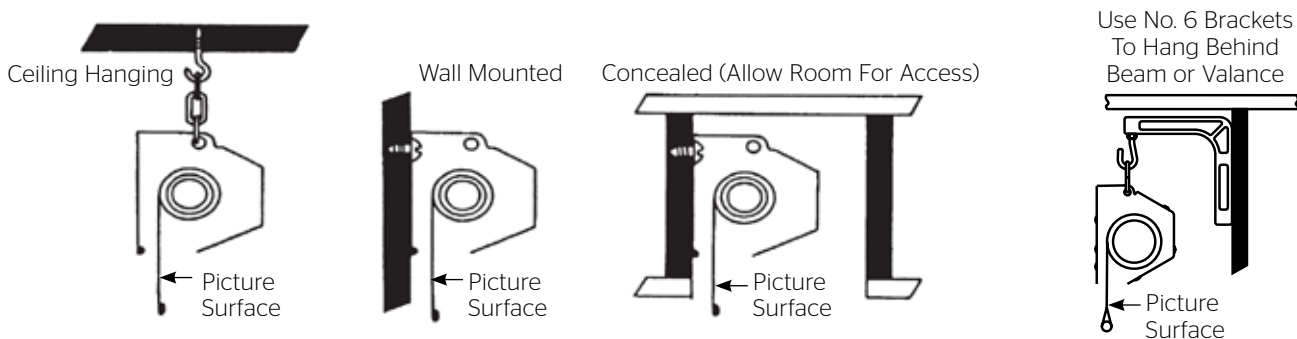

Figure 1

NOTE: Under no circumstances should unit be completely sealed in recessed installation. Allow access for service. Picture surface is centered in case. Case extends 4" beyond surface on either end. Do not attach anything to screen slat rod or bottom fabric pocket.

1. Make sure screen is level. Use a carpenter's level and plumb level.

CAUTION! Do not cut wrapping paper or tape with knife or any sharp tool. Remove by hand.

2. Remove tape and rubber bands from slat pocket.

3. Install electrical hook up that applies to your unit. Make sure to review your Electrical Installation Checklists and wiring diagrams (included) for either 120 volt switch, 220/240 volt switch, or low voltage control.

4. Test installation by running screen up and down a few times. Be prepared to stop screen. Standard Duty Cycle: 1 MIN. ON / 3 MIN. OFF.

NOTE: Must be installed in accordance with the requirements of the Local Building Codes, the Canadian Electrical Code (CEC), CAN/CSA C22.1 and the National Electric Code (NEC), NFPA 70.

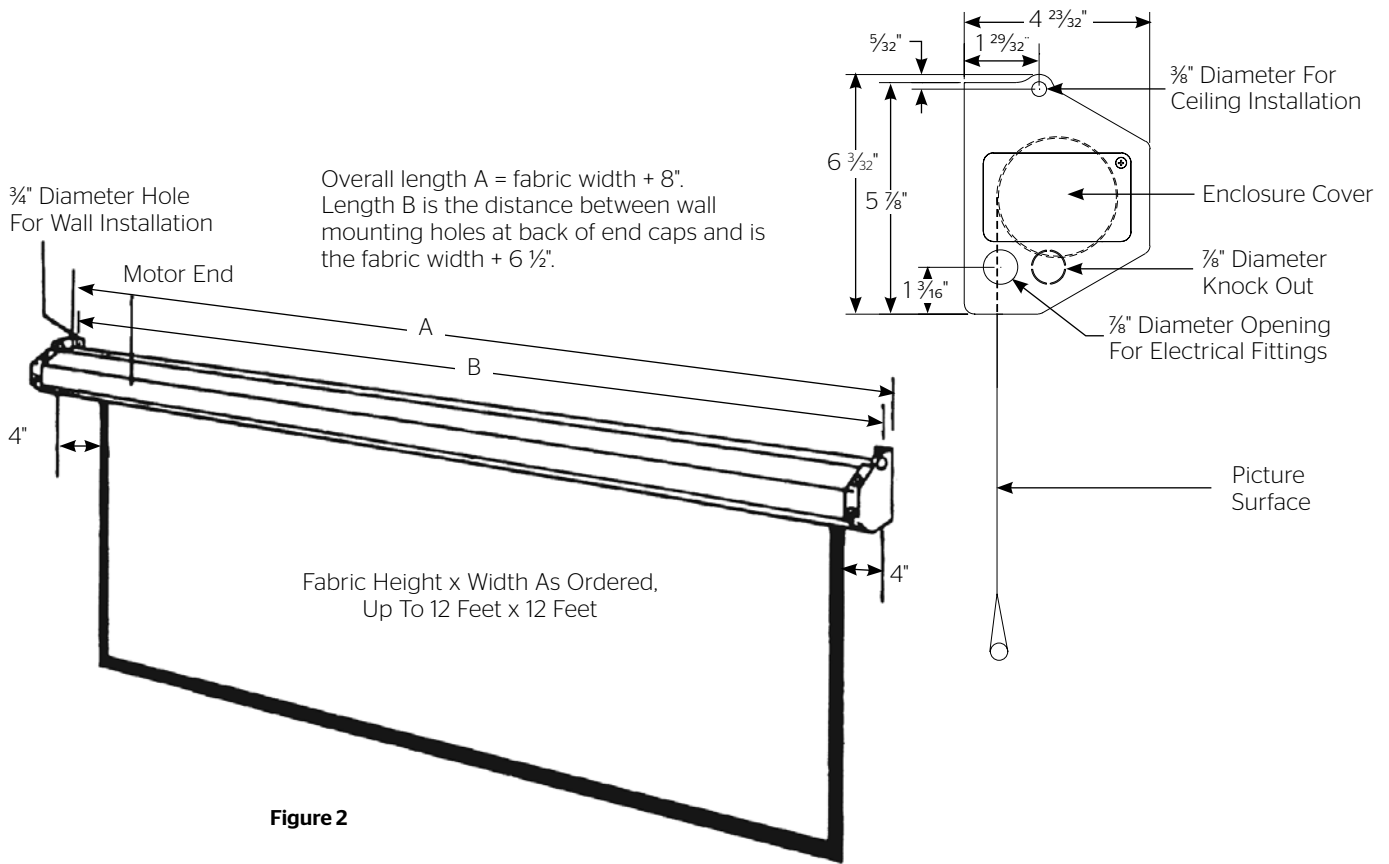

Figure 2

120V Wiring Diagram

NOTE: A single switch cannot be used to operate more than one screen. Contact the factory for further information.

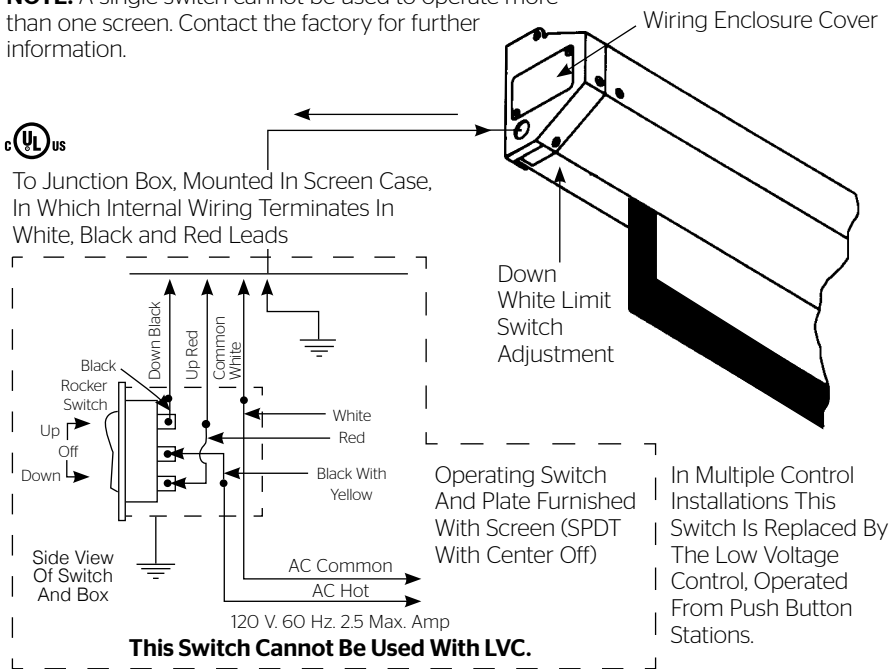

Figure 3

240 Volt Wiring Diagram For Standard Wall Switch:

Da-Lite offers two styles of 240 volt wall switches for standard operation. Please see wiring diagram included in wall switch box included with screen.

Screen Adjustment For Screens Without A Built-In Low Voltage Control

Surface travel is stopped automatically in the fully opened and closed positions by limit switches that are properly adjusted at Da-Lite. Should it be necessary to adjust for more or less picture drop (viewing area), proceed in the following manner:

NOTE: Use a screwdriver or 5/32" Allen wrench to make adjustments.

Setting The Down Limit Position

To Reduce Screen Drop:

Turn the white limit switch screw (Figure 3) clockwise to decrease the amount of screen drop. Run the screen down to test the stop position. If the screen drops too far, raise the screen about one foot and adjust the limit switch again. Repeat until the desired position is set.

To Increase Screen Drop:

Turn the white limit switch screw counterclockwise to increase the amount of screen drop. Run the screen down to test the stop position. If the screen does not drop enough, raise the screen about one foot and adjust the limit switch again. Repeat until the desired position is set. Do not adjust for more drop than what was ordered. At least 1-1/2 wraps of fabric must remain on the roller.

⚠ CAUTION: Do not adjust for more drop than what was ordered. At least 1-1/2 wraps of fabric must remain on the roller. This screen comes standard with 0" or 2" black at the top. See the specification data sheet for details.

120V Wiring Diagram with Optional Built-In Video Projector Interface

⚠ CAUTION: The projector must be turned off before connecting the trigger wires to the projector. Failure to do so may damage the controller.

Use 2-conductor 20-24 gauge wire to extend the low voltage connection from the projector's 5 or 12-volt screen trigger output to the length required to reach the VPI. When extending the low voltage connection from the projector's screen trigger output polarity does not matter. The red and black wires from the VPI are interchangeable.

IMPORTANT NOTE:

The wall switch is REQUIRED to make any limit switch adjustments, EVEN if a third party control system is used. Therefore, it is advised to wire the switch or provide a 3-conductor connection that is accessible.

3-conductor 20-24 gauge wire can be used in place of the supplied RJ-14 cable to connect the wall switch. Connect the BUS terminals on the wall switch to the corresponding BUS terminals on the splitter board.

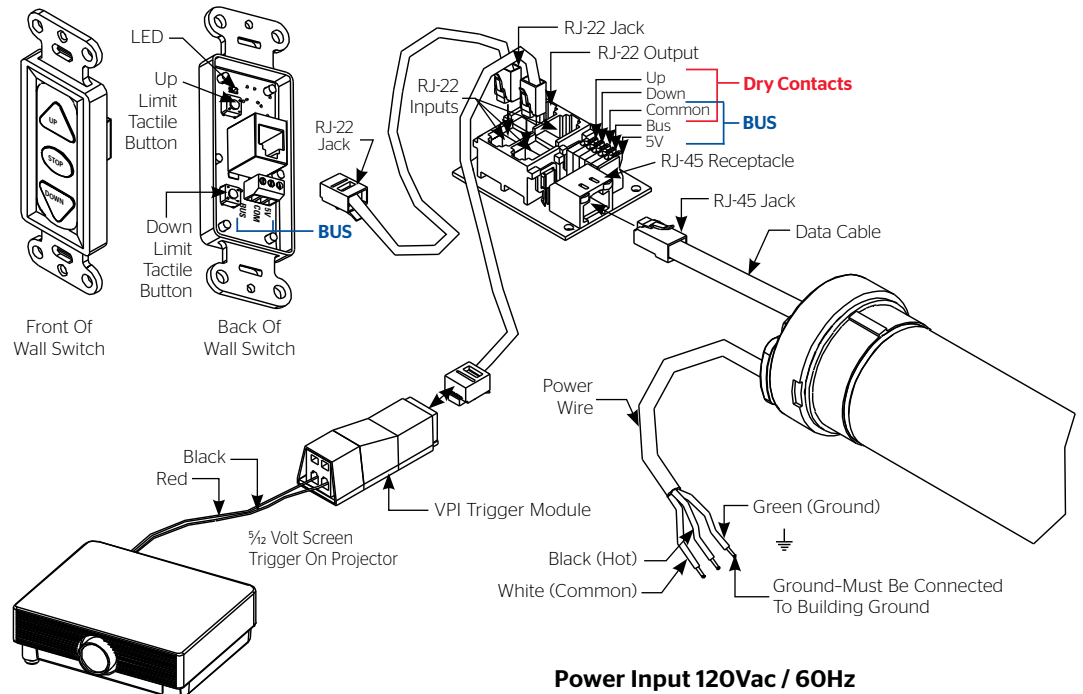
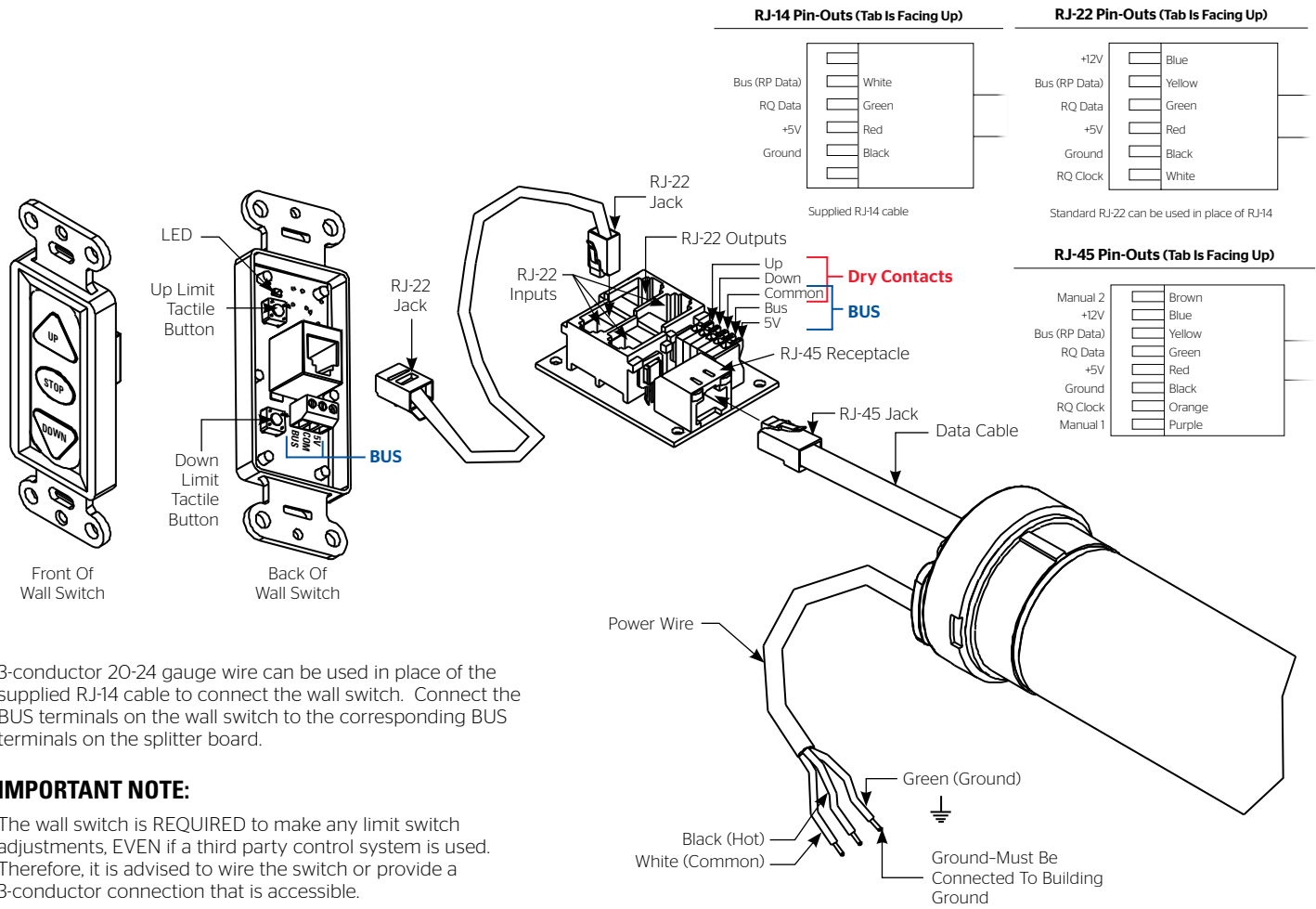

Figure 4

120V Wiring Diagram with Optional Built-In Low Voltage Control



Power Input 120VAC / 60HZ **Figure 5**

3-conductor 20-24 gauge wire can be used in place of the supplied RJ-14 cable to connect the wall switch. Connect the BUS terminals on the wall switch to the corresponding BUS terminals on the splitter board.

IMPORTANT NOTE:

The wall switch is REQUIRED to make any limit switch adjustments, EVEN if a third party control system is used. Therefore, it is advised to wire the switch or provide a 3-conductor connection that is accessible.

Screen Adjustment For 120V Screens With A Built-In Low Voltage Control or VPI

1. Locate the wall switch and remove the cover plate from the 3-button wall switch and remove the switch from the junction box.
 2. Locate the two tactile buttons on the back of the switch. They are square silver with black round buttons. See Figure 4 (VPI) or Figure 5 (LVC) for diagram.
 3. To adjust the down limit switch, press and hold the down tactile button until the LED on back of switch turns solid red. This will put the motor in limit set mode. Turn the wall switch over and use the down button on front of switch. Press and hold until the desired travel position is reached. If you travel to far down you can press the up to move the screen upward. If you press and let go of either up or down button the motor will do a small jog in that direction for finer adjustment of screen. Once desired position is reached turn switch over press and hold down tactile button until the LED on back of switch blinks red twice. The down limit is now set.
 4. To adjust the up limit switch, press and hold the up tactile button until the LED on back of switch turns solid green. This will put the motor in limit set mode. Turn the wall switch over and use the up button on front of switch. Press and hold until the desired travel position is reached. If you travel to far up you can press the down to move the screen downward. If you press and let go of either up or down button the motor will do a small jog in that direction for finer adjustment of screen. Once desired position is reached turn switch over press and hold up tactile button until the LED on back of switch blinks green twice. The up limit is now set.
 5. To test limit switch setting, press and release the up or down button on the wall switch to operate the screen.
 6. Replace switch and cover plate on the wall.
- NOTE:** If the screen is in limit set mode and no buttons are pushed for 20 seconds, the LED on the back of the wall switch will turn off, the motor will return to run mode and no changes will be saved. If this occurs, return to step 3 for down limit adjustment or step 4 for up limit adjustment.
- IMPORTANT NOTE:** The wall switch is REQUIRED to make any limit switch adjustments, EVEN if a third party control system is used. Therefore, it is advised to wire the switch or provide a 3-conductor connection that is accessible.

240V Wiring Diagram with Optional Built-In Low Voltage Control

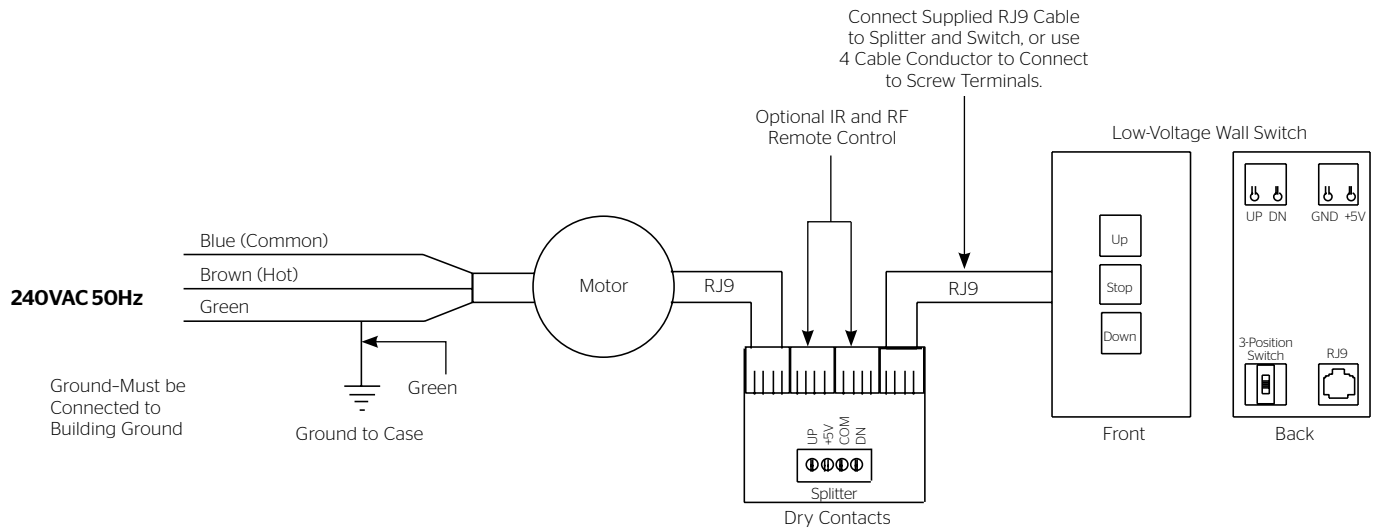

ILT RJ-9 Pin-Outs (Tab Is Facing Up)



IMPORTANT NOTE: The wall switch is REQUIRED to make any limit switch adjustments, EVEN if a third party control system is used. Therefore, it is advised to wire the switch or provide a 4-conductor connection that is accessible.

Figure 6

Screen Adjustment For 220V/240V Screens with A Built-In Low Voltage Control

1. Remove the cover plate from the 3-button wall switch and remove the switch from the junction box.
 2. Locate small 3-position switch on back of wall switch. (See Figure 6)
 3. To adjust the down limit switch, slide the 3-position switch to the down position. Press and hold the down button to run the screen down to the desired stop position. Release the button to stop the screen. DO NOT PUSH THE STOP BUTTON.
 4. When the screen is in the desired down position, slide the 3-position switch to the off (center) position. The down limit switch is now set.
 5. To adjust the up limit switch, slide the 3-position switch to the up position. Press and hold the up button to run the screen up to the desired stop position. Release the button to stop the screen. DO NOT PUSH THE STOP BUTTON.
 6. When the screen is in the desired up position, slide the 3-position switch to the off (center) position. The up limit switch is now set.
 7. To test limit switch setting, make sure the 3-position switch is in the off (center) position. Press and release the up or down button on the wall switch to operate the screen.
 8. Replace switch and cover plate on the wall.
- NOTE:** If stop button is pressed, the wall switch will reverse direction. To correct this, press the stop button again. This will reset the switch. You will have to re-set both the up and the down settings.
- IMPORTANT NOTE:** The wall switch is REQUIRED to make any limit switch adjustments, EVEN if a third party control system is used. Therefore, it is advised to wire the switch or provide a 4-conductor connection that is accessible.

Troubleshooting

Visit www.da-lite.com/products/tutorials.php to find installation and troubleshooting tutorials. You will also find a link to Live Chat for interactive support and you can contact us by email at

info@da-lite.com or by phone at (800) 622-3737 or (574) 267-8101 with any troubleshooting questions.

Symptom	Cause	Solution	
Screen will not operate. Motor does not hum.	Incorrect line voltage.	Verify 115-125V (or 220-240V). If insufficient voltage, rewire incoming electric line.	
	Blown fuse.	Replace fuse.	
	Tripped circuit breaker.	Reset circuit breaker.	
	No power to operating switch or junction.		Check above. Tighten all loose wire connections. Correct any improper connections. "Down" Position Check for power across black and white leads. "Up" Position Check for power across red and white leads.
			Power at junction box. Thermal overload tripped.
	Motor hums.	Broken wire in the "up" or "down" position.	Check for continuity. Cut off old splice and reconnect.
		Defective motor, limit switch or capacitor.	Replace motor assembly. NOTE: Motor is a sealed assembly.
	Capacitor burned out.	Replace motor assembly.	
Incorrect stopping position in downward direction.	Lost roller wrap.	See instructions below.	
	"Down" limit switch out of adjustment.	See installation instructions.	
Incorrect stopping position in upward direction.	Lost roller wrap.	See instructions below.	
	"Up" limit switch out of adjustment.	Adjust "up" limit switch. Call factory for instructions.	
Noise. NOTE: Screen will operate with a low pitched hum.	Gear noise.	Replace motor assembly.	
Coasting.	Defective brake.	Replace motor assembly.	
Roller displaced from mounting bracket.	Pin end slipped out of nylon bearing.	Realign pin end bracket.	

Restoring Lost Roller Wrap

1. Push strap over back of roller.
2. Tape end of strap to pocket.
3. Feed fabric as you pull strap to draw fabric over top.
4. Remove tape and strap.

LIMITED ONE YEAR WARRANTY ON DA-LITE PRESENTATION PRODUCTS

Milestone AV Technologies LLC warrants certain Da-Lite branded products to the original purchaser only, to be free from defects in materials and workmanship for a period of one (1) year from the date of purchase by the original purchaser; provided they are properly operated according to Da-Lite's instructions and are not damaged due to improper handling or treatment after shipment from the factory.

This warranty does not apply to equipment showing evidence of misuse, abuse or accidental damage, or which has been tampered with or repaired by a person other than authorized Da-Lite personnel.

Da-Lite's sole obligation under this warranty shall be to repair or to replace (at Da-Lite's option) the defective part of the merchandise. Returns for service should be made to your Da-Lite dealer. If it is necessary for the dealer to return the screen or part to Da-Lite, transportation expenses to and from

Da-Lite are payable by the purchaser and Da-Lite is not responsible for damage in shipment.

To protect yourself against damage or loss in transit, insure the product and prepay all transportation expenses.

TO THE MAXIMUM EXTENT PERMITTED BY APPLICABLE LAW, THIS WARRANTY IS IN LIEU OF ALL OTHER WARRANTIES, EXPRESS OR IMPLIED, INCLUDING WARRANTIES AS TO FITNESS FOR USE AND MERCHANTABILITY. Any implied warranties of fitness for use, or merchantability, that may be mandated by statute or rule of law are limited to the one (1) year warranty period. This warranty gives you specific legal rights, and you may also have other rights, which vary from state-to-state.

TO THE MAXIMUM EXTENT PERMITTED BY APPLICABLE LAW, NO LIABILITY IS ASSUMED FOR EXPENSES OR DAMAGES RESULTING FROM INTERRUPTION IN OPERATION OF EQUIPMENT, OR FOR INCIDENTAL, DIRECT, OR CONSEQUENTIAL DAMAGES OF ANY NATURE.

In the event that there is a defect in materials or workmanship of a Da-Lite product, you may contact our Sales Partners at PO Box 137, Warsaw, IN 46581-0137, (574) 267-8101, (800) 622-3737.

IMPORTANT: THIS WARRANTY SHALL NOT BE VALID AND DA-LITE BRANDED PRODUCTS SHALL NOT BE BOUND BY THIS WARRANTY IF THE PRODUCT IS NOT OPERATED IN ACCORDANCE WITH THE DA-LITE WRITTEN INSTRUCTIONS.

Keep your sales receipt to prove the date of purchase and your original ownership.



A Milestone AV Technologies Brand

3100 North Detroit Street
Warsaw, Indiana 46582
P: 574.267.8101 or 800.622.3737
F: 574.267.7804 or 877.325.4832
E: info@da-lite.com
www.da-lite.com

DL-0256 12.13

© 2013 Milestone AV Technologies LLC. Printed in U.S.A.

46832