



INSTRUCTION BOOK FOR
Tensioned Contour[®] Electrol[®]



Original Instructions

Disclaimer

Milestone and its affiliated corporations and subsidiaries (collectively "Milestone"), intend to make this manual accurate and complete. However, Milestone makes no claim that the information contained herein covers all details, conditions or variations, nor does it provide for every possible contingency in connection with the installation or use of this subject to change without notice or obligation of any kind. Milestone makes no representation of warranty, expressed or implied, regarding the information contained herein. Milestone assumes no responsibility for accuracy, completeness or sufficiency of the information contained in this document.

Da-Lite® is a registered trademark of Milestone AV Technologies. All rights reserved.

Important Safety Instructions

When using your video equipment, basic safety precautions should always be followed, including the following:

1. Read and understand all instructions before using.
2. Position the cord so that it will not be tripped over, pulled, or contact hot surfaces.
3. If an extension cord is necessary, a cord with a current rating at least equal to that of the appliance should be used. Cords rated for less amperage than the appliance may overheat.
4. To reduce the risk of electric shock, do not disassemble this appliance. Contact an authorized service dealer when repair work is required. Incorrect reassembly can cause electric shock when the appliance is used subsequently.
5. The use of an accessory attachment not recommended by the manufacturer may cause a risk of fire, electric shock, or injury to persons.
6. Failure to provide adequate structural strength for this component can result in serious personal injury or damage to equipment! It is the installer's responsibility to make sure the structure to which this component is attached can support the weight of all equipment. Reinforce the structure as required before installing the component.
7. Use this projection screen only for its intended use as described in these instructions. Do not use attachments not recommended by the manufacturer.

Save These Instructions

Tools Required for Installation

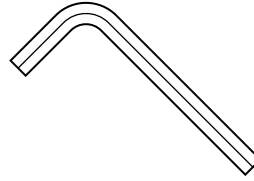

1/8" Hex Key
(included)

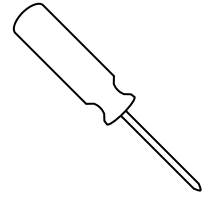

#2 Phillips Screwdriver

Pre-Installation

1. Carefully unpack screen and remove outer wrapping from case.
2. Set aside the Installation Kit. Items inside will be used during installation.

Installation

NOTE: Carefully unpack screen. Use supplied 1/8" hex key to remove silver shipping brackets attached to slat and screen case.

There are three ways to install the Tensioned Contour Electrol – Wall Mount, Ceiling Mount, or Ceiling Hook. Procedures for each method are as follows:

Wall Mount

1. Using a #2 Phillips screwdriver, loosen the two stop screws and remove the wall mount bracket from the back side of the case (Figure 1).

NOTE: The ceiling flush mount and ceiling hook mount brackets are attached to the top side of the case. These brackets are not necessary for wall mounting and can be removed at this time.

2. Secure the wall mount bracket to the wall at the desired height. The wall mount bracket should be fastened to the wall studs or some reinforcement within the wall. Concrete or brick walls require special fasteners and anchors. Allow at least 3" above the wall mount bracket to be able to position the case on the bracket (Figure 2).
3. Make sure the bracket is level.
4. Hang the screen case on the wall mount bracket as shown in Figure 2. Be sure the case is fully seated on the bracket.
5. Tighten the two stop screws against the wall mount bracket using a #2 Phillips screwdriver (Figure 1).

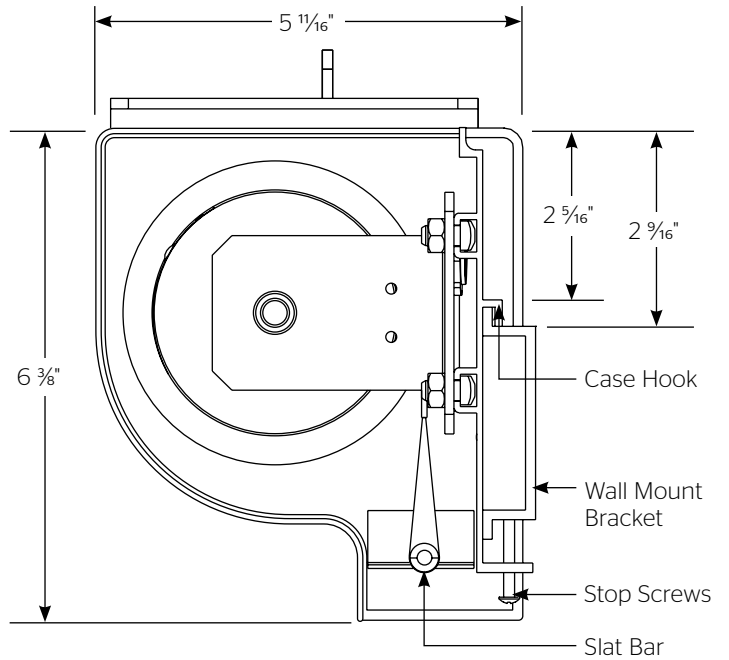

Figure 1

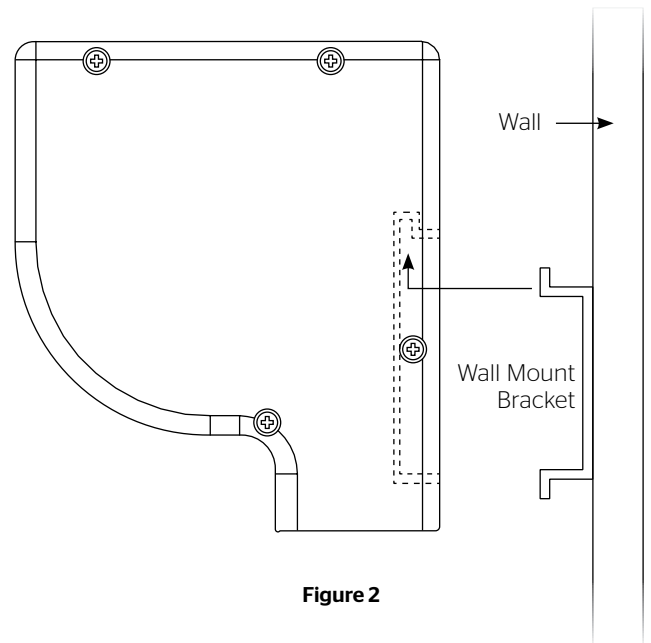

Figure 2

Installation (continued)

Ceiling Flush Mount

1. The ceiling hook brackets are attached to the top side of the housing. They must be removed prior to ceiling flush mount.

NOTE: Do not remove the wall mount bracket, even if you are not using it for mounting. This provides structural stability to the case.

2. Using a #2 Phillips screwdriver, loosen the four 1/4"x 5/8" screws holding the ceiling flush mount brackets (Figure 3).
3. Slide the ceiling flush mount brackets so that the mounting holes extend beyond the ends of the case. All four 1/4"x 5/8" screws must remain within the channels.
4. Tighten the four 1/4"x 5/8" screws holding the ceiling flush mount brackets (Figure 3).
5. Before mounting your Tensioned Contour Electrol, be sure the ceiling has adequate reinforcement.
6. Hold the screen case up to the ceiling and mark the hole locations. The brackets have a set of front holes and a set of rear holes. Attach the Tensioned Contour Electrol using the appropriate hardware for your ceiling type. It is best to use at least one hole in each set.

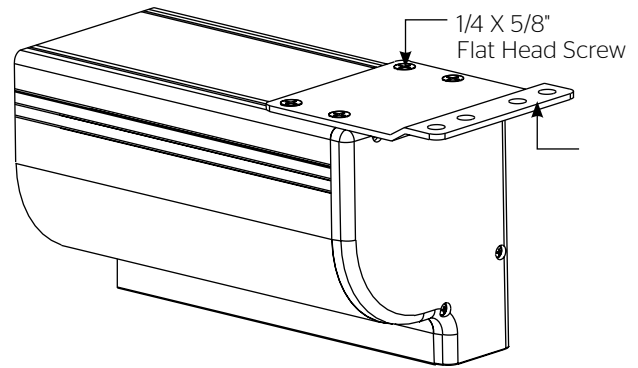

Figure 3

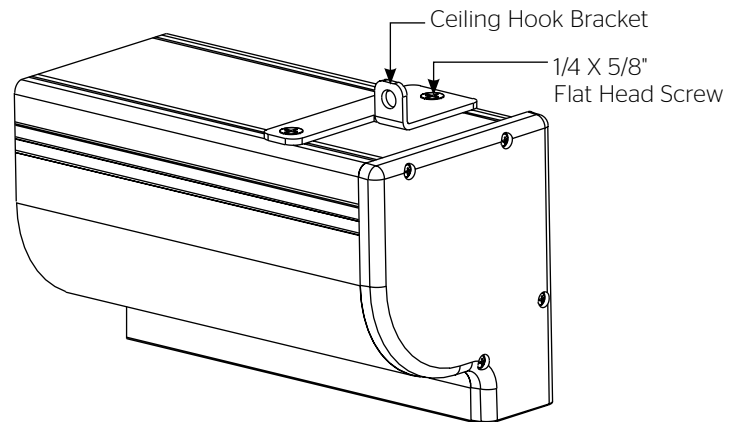

Figure 4

Ceiling Hook Mount

1. The ceiling hook mount brackets are tied together and attached to the ceiling flush mount bracket at one end of the case. Remove the ceiling hook mount brackets.
2. Remove the ceiling flush mount brackets using a #2 Phillips screwdriver. See Figure 3. Retain four 1/4"x 5/8" screws.

NOTE: Do not remove the wall mount bracket, even if you are not using it for mounting. This provides structural stability to the case.

3. The top of the screen case has two channels with threaded nuts that slide the length of the case. Attach the two ceiling hook mount brackets using the 1/4"x 5/8" screws and threaded nuts, two per bracket. The brackets can be attached anywhere within 12" of the ends of the case (Figure 4).
4. Before hanging your Tensioned Contour Electrol, be sure the ceiling has adequate reinforcement.
5. Using the holes in the ceiling hook brackets, hang the Tensioned Contour Electrol using the appropriate hardware and fasteners for your ceiling type.

Electrical Installation

1. Open the junction box on the left end of the case using a #2 Phillips screwdriver. Install electrical connections that apply to your unit. Make sure to review the wiring diagram for proper hook up. Replace the junction box cover.

NOTE: Must be installed in accordance with the requirements of the Local Building Codes, the Canadian Electrical Code (CEC), CAN/CSA C22.1 and the National Electric Code (NEC), NFPA 70.

2. Test installation by running screen up and down a few times. Be prepared to stop screen should any objects obstruct the movement of the screen. To prevent damage to the motor, the standard duty cycle is 1 minute on and 3 minutes off.

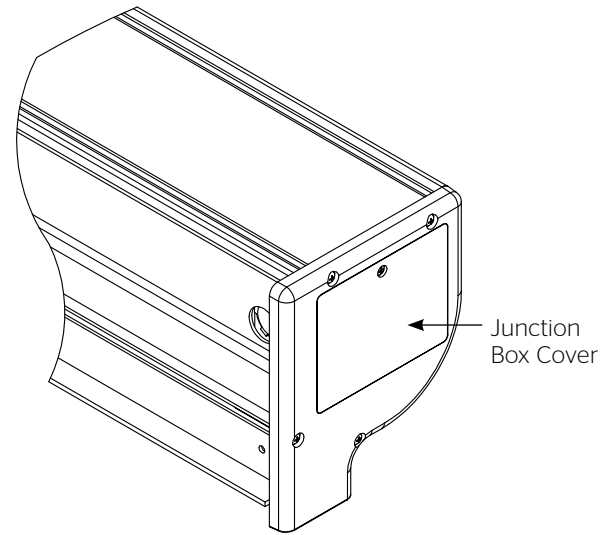

Figure 5

Tensioned Contour® Electrol® Installation for 120V Screens

120V Wiring Diagram

3-conductor 20-24 gauge wire can be used in place of the supplied RJ-14 cable to connect the wall switch. Connect the BUS terminals on the wall switch to the corresponding BUS terminals on the splitter board.

IMPORTANT NOTE: The wall switch is REQUIRED to make any limit switch adjustments, EVEN if a third party control system is used. Therefore, it is advised to wire the switch or provide a 3-conductor connection that is accessible.

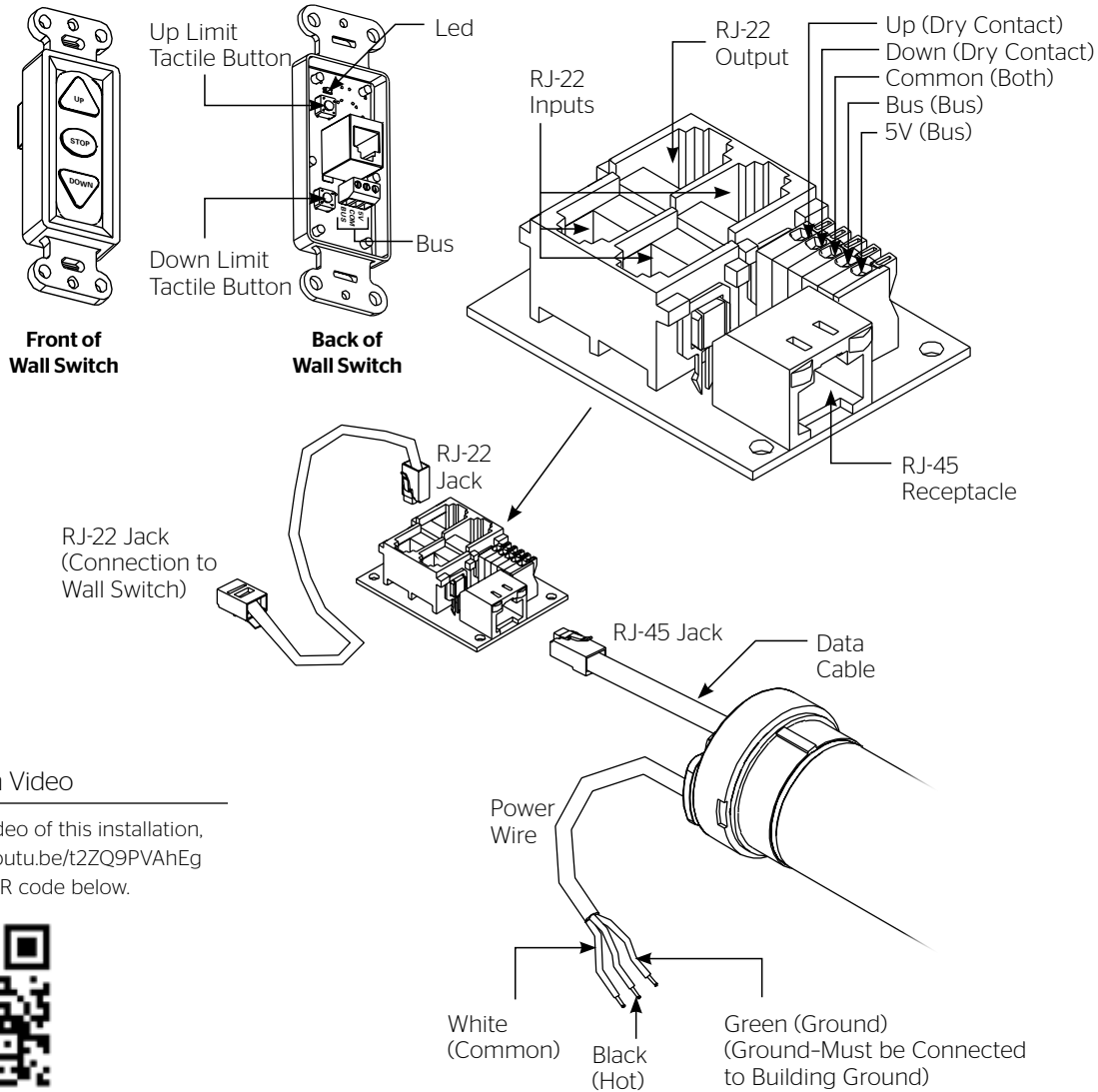

Installation Video

To view a video of this installation, visit <http://youtu.be/t2ZQ9PVAhEg> or use the QR code below.



Power Input 120VAC / 60Hz

RJ-14 Pin-Outs (Tab Is Facing Down)

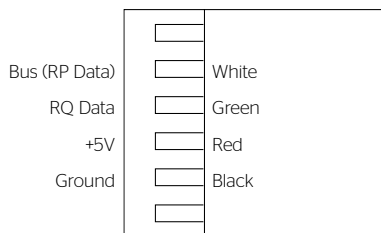

Supplied RJ-14 cable

RJ-22 Pin-Outs (Tab Is Facing Down)

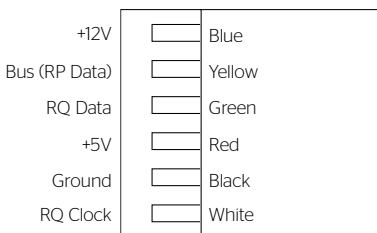

Standard RJ-22 can be used in place of RJ-14 cable

RJ-45 Pin-Outs (Tab Is Facing Down)

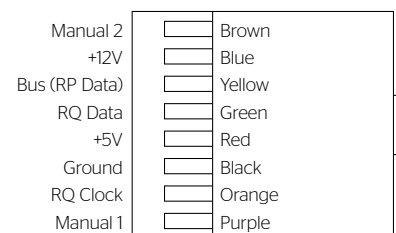

Tensioned Contour® Electrol® Installation for 120V Screens

120V Wiring Diagram with Optional Built-In Video Projector Interface

⚠ CAUTION: The projector must be turned off before connecting the trigger wires to the projector. Failure to do so may damage the controller.

⚠ ATTENTION: Le projecteur doit être éteint avant de brancher les fils de déclenchement à celui-ci. Tout manquement à cette instruction pourrait endommager le contrôleur.

Use 2-conductor 18-24 gauge wire to extend the low voltage connection from the projector's 5 or 12-volt screen trigger output to the length required to reach the VPI. When extending the low voltage connection from the projector's screen trigger output polarity does not matter. The red and black wires from the VPI are interchangeable.

IMPORTANT NOTE: The wall switch is REQUIRED to make any limit switch adjustments, EVEN if a third party control system is used. Therefore, it is advised to wire the switch or provide a 3-conductor connection that is accessible.

3-conductor 20-24 gauge wire can be used in place of the supplied RJ-14 cable to connect the wall switch. Connect the BUS terminals on the wall switch to the corresponding BUS terminals on the splitter board.

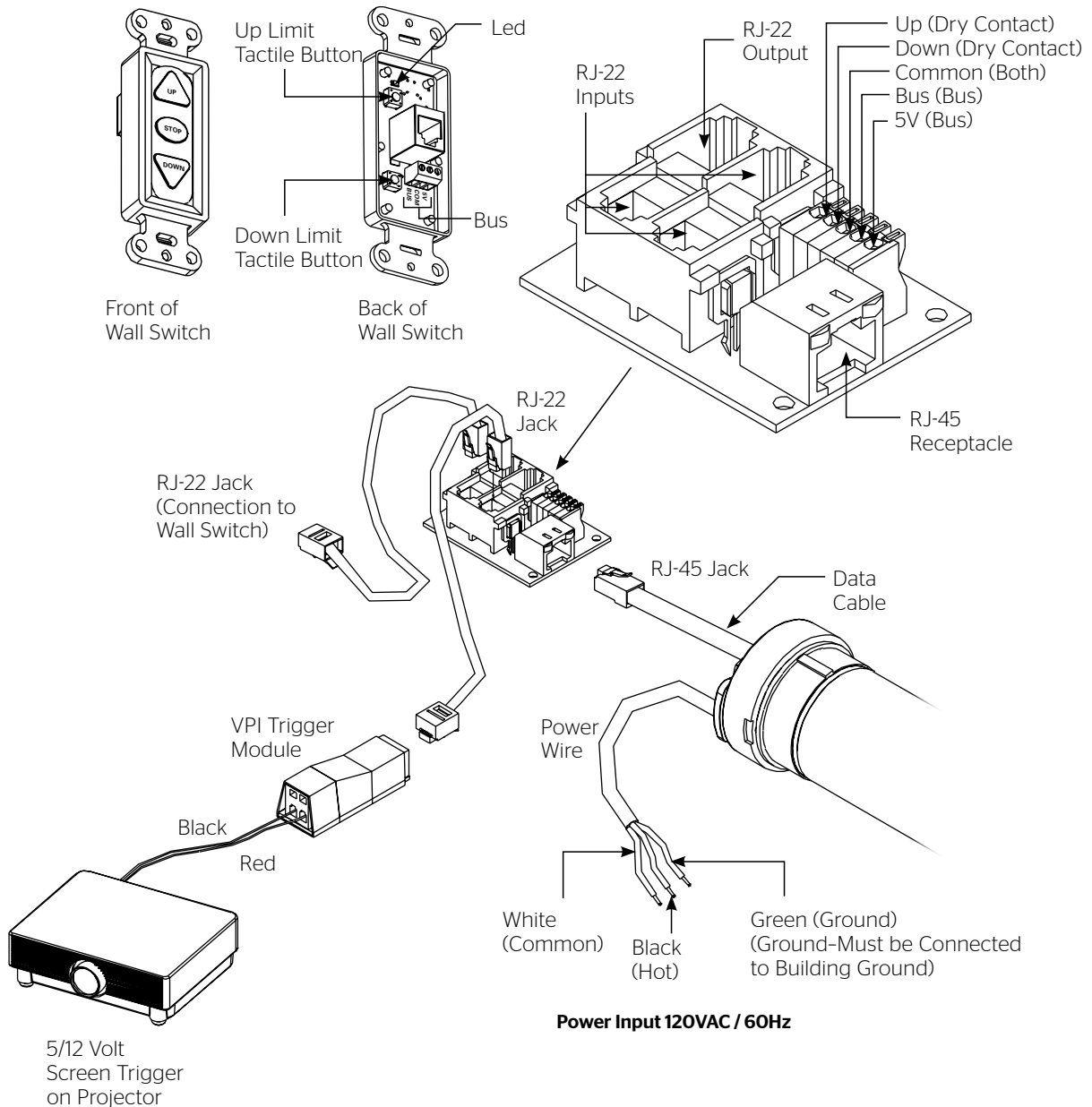

Tensioned Contour® Electrol® Installation for 240V Screens

240V Wiring Diagram

IMPORTANT NOTE: The wall switch is REQUIRED to make any limit switch adjustments, EVEN if a third party control system is used. Therefore, it is advised to wire the switch or provide a 4-conductor connection that is accessible.

ILT RJ-9 Pin-Outs (Tab Is Facing Down)

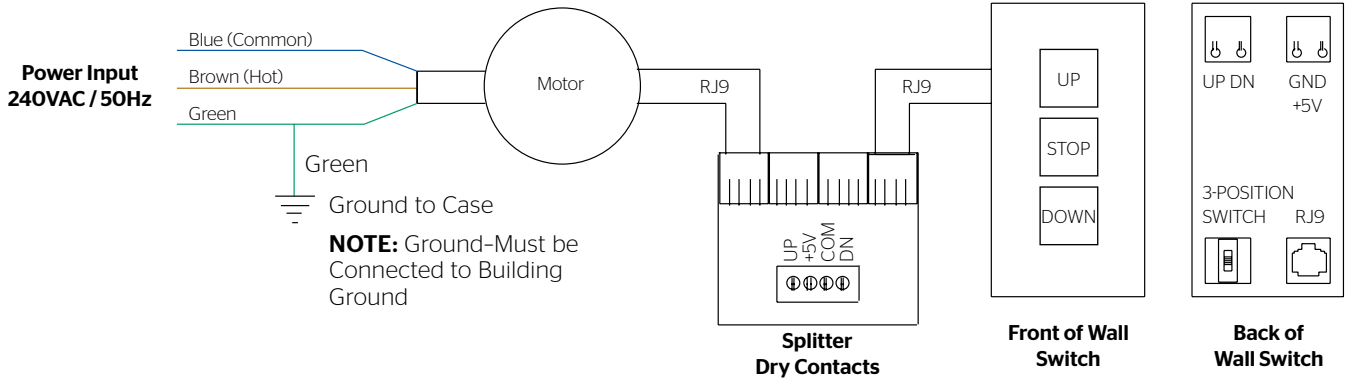

240V Wiring Diagram with Optional Built-in Video Projector Interface

CAUTION: The projector must be turned off before connecting the trigger wires to the projector. Failure to do so may damage the controller.

ATTENTION: Le projecteur doit être éteint avant de brancher les fils de déclenchement à celui-ci. Tout manquement à cette instruction pourrait endommager le contrôleur.

1. Use 2-conductor 20-24 gauge wire to extend the low voltage connection from the projector's 5 or 12-volt screen trigger output to the length required to reach the VPI. When extending the low voltage connection from the projector's

screen trigger output, be sure to maintain the proper polarity. The red wire from the VPI is the "signal" and the black wire from the VPI is the "ground".

2. Connect the wires from the VPI that are labeled "Low Voltage Connection" to the end of the extended screen trigger wires above.

IMPORTANT NOTE: The wall switch is REQUIRED to make any limit switch adjustments, EVEN if a third party control system is used. Therefore, it is advised to wire the switch or provide a 4-conductor connection that is accessible.

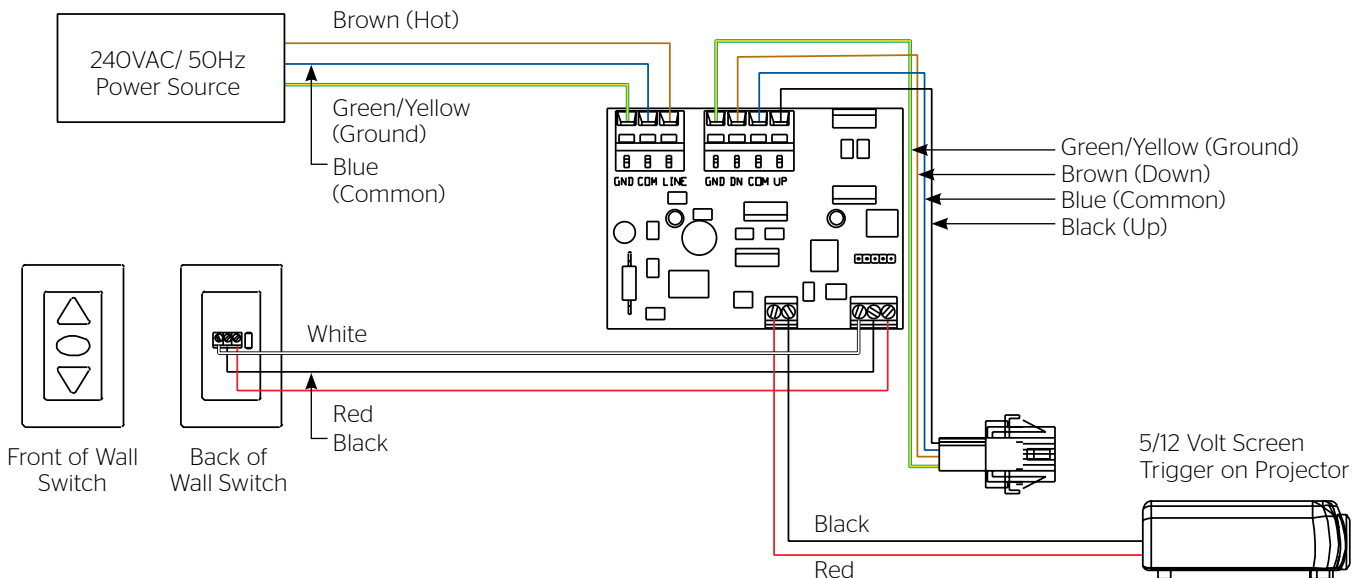

Screen Adjustment for 120V Screens

If your Tensioned Contour Electrol was ordered as a complete unit, the up and down limits were pre-set by Da-Lite. If your screen and roller assembly was ordered separately from the case, or if general adjustment is needed, please follow the steps below and refer to the 120V Wiring Diagram.

1. Locate the wall switch and remove the cover plate from the wall switch and remove the switch from the junction box.
2. Locate the two tactile buttons on the back of the switch. They are black round buttons on silver plates. See 120V Wiring Diagram.
3. To adjust the down limit switch, press and hold the down tactile button until the LED on the back of the switch turns solid red. This will put the motor in limit set mode. Turn the wall switch over and use the down button on the front of the switch. Press and hold the down button until the desired down position is reached. If you travel too far down, press the up button to move the screen upward. If you press and let go of either the up or down buttons, the motor will do a small jog in that direction for fine adjustment of the screen. Once the desired position is reached, turn the switch over; press and hold the down tactile button until the LED on back of switch blinks red twice. The down limit is now set.

⚠ CAUTION: Do not adjust for more drop than what was ordered. At least 1-1/2 wraps of fabric must remain on the roller. This screen comes standard with 12" black at the top.

⚠ ATTENTION! N'effectuez pas de réglage pour obtenir un déroulement supérieur à celui commandé. Au moins 1 à 1/2 tour de toile doit être maintenu sur le cylindre. Ce écran est doté de série d'une bande noire supérieure de 30,5 cm (12 po).

NOTE: If the screen is in limit set mode and no buttons are pushed for 20 seconds, the LED on the back of the wall

switch will turn off, the motor will return to run mode and no changes will be saved. If this occurs, return to step 3 for down limit adjustment or step 4 for up limit adjustment.

4. To adjust the up limit switch, press and hold the up tactile button until the LED on the back of the switch turns solid green. This will put the motor in limit set mode. Turn the wall switch over and use the up button on the front of the switch. Press and hold the up button until the desired up position is reached. If you travel too far up, press the down button to move the screen downward. If you press and let go of either the up or down buttons, the motor will do a small jog in that direction for fine adjustment of the screen. Once the desired position is reached, turn the switch over; press and hold the up tactile button until the LED on back of switch blinks green twice. The up limit is now set.

⚠ CAUTION: Adjusting the down limit switch for less drop by more than 6" can cause the screen surface to lose proper tensioning.

⚠ ATTENTION! Le fait d'ajouter ne déroulez pas trop l'écran plus de 15 cm (6po) aux interrupteurs de fin de course peut faire perdre la bonne tension à la surface de l'écran.

5. To test the limit switch settings, press and release the up or down buttons on the switch to operate the screen.
6. Replace the switch and cover plate on the wall.

IMPORTANT NOTE: The wall switch is REQUIRED to make any limit switch adjustments, even if a third party control system is used. Therefore, it is advised to wire the switch or provide a 3-conductor connection that is accessible.

Low Voltage Connections for 120V Screens

Control Panel

A control panel may be connected to the splitter board by using the dry contact Up, Down and Common connections. The control panel must provide a momentary, dry contact closure of at least 1/2 second.

1. Use 3-conductor 20-24 gauge wire to connect the control panel to the splitter board.
2. A momentary closure across the common and up wires will be an "up" command.
3. A momentary closure across the common and down wires will be a "down" command.
4. A momentary closure across the common, up and down wires will be a "stop" command.

Screen Adjustment for 220V/240V Screens

1. Remove the cover plate from the 3-button wall switch and remove the switch from the junction box.
2. Locate small 3-position switch on back of wall switch. See Figure 5 for 120V screens or Figure 8 for 220/240V screens.
3. To adjust the down limit switch, slide the 3-position switch to the down position. Press and hold the down button to run the screen down to the desired stop position. Release the button to stop the screen. **DO NOT PUSH THE STOP BUTTON.**

⚠ CAUTION: Do not adjust for more drop than what was ordered. At least 1-1/2 wraps of fabric must remain on the roller. This screen comes standard with 12" black at the top. See the specification data sheet for details.

⚠ ATTENTION! N'effectuez pas de réglage pour obtenir un déroulement supérieur à celui commandé. Au moins 1 à 1/2 tour de toile doit être maintenu sur le cylindre. Ce écran est doté de série d'une bande noire supérieure de 30,5 cm (12 po).

4. When the screen is in the desired down position, slide the 3-position switch to the off (center) position. The down limit switch is now set.
5. To adjust the up limit switch, slide the 3-position switch to the up position. Press and hold the up button to run the screen up to the desired stop position. Release the button to stop the screen. **DO NOT PUSH THE STOP BUTTON.**

⚠ CAUTION: Adjusting the down limit switch for less drop by more than 6" can cause the screen surface to lose proper tensioning.

⚠ ATTENTION! Le fait d'ajouter ne déroulez pas trop l'écran plus de 15 cm (6po) aux interrupteurs de fin de course peut faire perdre la bonne tension à la surface de l'écran.

6. When the screen is in the desired up position, slide the 3-position switch to the off (center) position. The up limit switch is now set.
7. To test limit switch setting, make sure the 3-position switch is in the off (center) position. Press and release the up or down button on the wall switch to operate the screen.
8. Replace switch and cover plate on the wall.

NOTE: If stop button is pressed, the wall switch will reverse direction. To correct this, press the stop button again. This will reset the switch. You will have to re-set both the up and the down limit settings.

IMPORTANT NOTE: The wall switch is REQUIRED to make any limit switch adjustments, EVEN if a third party control system is used. Therefore, it is advised to wire the switch or provide a 4-conductor connection that is accessible.

Low Voltage Connections for 220V/240V Screens

Control Panel

A control panel may be connected to the integrated LVC by using the wall switch wire lead. The control panel must provide a momentary, dry contact closure of at least 1/2 second.

1. Use 3-conductor 20-24 gauge wire to connect the control panel to the wall switch lead.
2. A momentary closure across the white and red wires will be an "up" command.
3. A momentary closure across the white and black wires will be a "down" command.
4. A momentary closure across the white, red and black wires will be a "stop" command.

Troubleshooting

Symptom	Cause	Solution
Screen will not operate and motor does not hum.	Incorrect line voltage.	Verify 115-125V (or 220-240V). If insufficient voltage, rewire incoming electric line.
	Blown fuse.	Replace fuse.
	Tripped circuit breaker.	Reset circuit breaker.
	No power to operating switch or junction.	Check above. Tighten all loose wire connections. Correct any improper connections. Down Position Check for power across black and white leads. Up Position Check for power across red and white leads.
Screen will not operate and motor does not hum. Power at junction box.	Thermal overload tripped.	Let motor cool down for 15 minutes. Try again.
	Broken wire in the "down" or "up" position.	Check for continuity. Cut off old splice and reconnect.
	Defective motor, limit switch or capacitor.	Replace motor assembly. NOTE: Motor is a sealed assembly.
	Capacitor burned out.	Replace motor assembly.
Incorrect stopping position in downward direction.	Lost roller wrap.	See instructions below.
	"Down" limit switch out of adjustment.	See installation instructions.
Incorrect stopping position in upward direction.	Lost roller wrap.	See instructions below.
	"Up" limit switch out of adjustment.	Adjust "up" limit switch. Call for information.
Noise. NOTE: Screen will operate with a low pitched hum.	Squeaking, rubber end plug rubbing on motor.	Center roller in case.
	Grinding. Foreign object in screen rubbing on roller or fabric.	Remove.
	Gear noise.	Replace motor assembly.
Coasting.	Defective brake.	Replace motor assembly.

Restoring Lost Roller Wrap

1. Tape a strap to the bottom of the screen surface.
2. Push strap over back of roller.
3. Feed fabric as you pull strap to draw fabric over top of roller.
4. Remove tape and strap.

LIMITED FIVE YEAR WARRANTY ON DA-LITE TENSIONED ADVANTAGE® ELECTROL®, ADVANTAGE® ELECTROL®, TENSIONED LARGE ADVANTAGE® ELECTROL®, LARGE ADVANTAGE® ELECTROL®, TENSIONED CONTOUR® ELECTROL® AND CONTOUR® ELECTROL® PRODUCTS ONLY

Milestone AV Technologies LLC warrants these Da-Lite branded products to the original purchaser only, to be free from defects in materials and workmanship for a period of five (5) years from the date of purchase by the original purchaser; provided they are properly operated according to Da-Lite's instructions and are not damaged due to improper handling or treatment after shipment from the factory.

This warranty does not apply to equipment showing evidence of misuse, abuse or accidental damage, or which has been tampered with or repaired by a person other than authorized Da-Lite personnel.

Da-Lite's sole obligation under this warranty shall be to repair or to replace (at Da-Lite's option) the defective part of the merchandise. Returns for service should be made to your Da-Lite dealer. If it is necessary for the dealer to return the screen or part to Da-Lite, transportation expenses to and from Da-Lite are payable by the purchaser and Da-Lite is not responsible for damage in shipment.

To protect yourself against damage or loss in transit, insure the product and prepay all transportation expenses.

TO THE MAXIMUM EXTENT PERMITTED BY APPLICABLE LAW, THIS WARRANTY IS IN LIEU OF ALL OTHER WARRANTIES, EXPRESS OR IMPLIED, INCLUDING WARRANTIES AS TO FITNESS FOR USE AND MERCHANTABILITY. Any implied warranties of fitness for use, or merchantability, that may be mandated by statute or rule of law are limited to the five (5) year warranty period. This warranty gives you specific legal rights, and you may also have other rights, which vary from state-to-state. **TO THE MAXIMUM EXTENT PERMITTED BY APPLICABLE LAW, NO LIABILITY IS ASSUMED FOR EXPENSES OR DAMAGES RESULTING FROM INTERRUPTION IN OPERATION OF EQUIPMENT, OR FOR INCIDENTAL, DIRECT, OR CONSEQUENTIAL DAMAGES OF ANY NATURE.**

In the event that there is a defect in materials or workmanship of a Da-Lite product, you may contact our Customer Care Specialists at 3100 North Detroit Street, Warsaw, IN 46582, (574) 267-8101, (800) 622-3737.

IMPORTANT: THIS WARRANTY SHALL NOT BE VALID AND DA-LITE BRANDED PRODUCTS SHALL NOT BE BOUND BY THIS WARRANTY IF THE PRODUCT IS NOT OPERATED IN ACCORDANCE WITH THE DA-LITE WRITTEN INSTRUCTIONS.

Keep your sales receipt to prove the date of purchase and your original ownership.



A BRAND OF MILESTONE AV TECHNOLOGIES | www.milestone.com

P 800.622.3737 / 574.267.8101 **F** 877.325.4832 / 574.267.7804

E info@da-lite.com

In British Columbia, Milestone AV Technologies ULC carries on business as MAVT Milestone AV Technologies ULC.

©2016 Milestone AV Technologies. DL-0116 (Rev. 5) 1014.

Da-Lite is a registered trademarks of Milestone AV Technologies. All other brand names or marks are used for identification purposes and are trademarks of their respective owners. All patents are protected under existing designations. Other patents pending.