



ADVANTAGE® ELECTROL®

(UP TO 12' x 12')

Automatic Electric Projection Screen Model

DA-LITE SCREEN COMPANY, INC.
 3100 North Detroit Street
 Post Office Box 137
 Warsaw, Indiana 46581-0137
 Phone: 574-267-8101
 800-622-3737
 Fax: 574-267-7804
 Toll Free Fax: 877-325-4832
 www.da-lite.com
 e-mail: info@da-lite.com

SPECIFICATION DATA

SUGGESTED SPECIFICATIONS: _____ projection screen(s), _____ (H) x _____ (W), electrically operated 120 volt (60Hz), not more than 2.4 amp with a quick connect male plug-in connector on the motor. Shall have specially designed motor mounted inside the roller, to be three wire with ground, quick reversal type, oiled for life, with automatic thermal overload cutout, integral gears, capacitor and an electric brake to prevent coasting. To have preset but adjustable limit switches to automatically stop picture surface in the "up" and "down" positions. Junction box shall be externally integrated into the housing making it possible to install the housing and wire to the building's electrical system during construction. The junction box shall contain a quick connect connector that is mounted in the housing for easy plug-in connection to the motorized fabric and roller assembly. The roller to be of rigid metal. The motorized fabric and roller assembly to be installed in the case at the factory or at a later time at the job site. Roller mounting brackets to be adjustable to allow centering or offsetting of the screen within the case. Screen to be designed for left or right-hand motor installation. Screen fabric to be flame retardant and mildew resistant fiberglass with black masking borders standard. Bottom of fabric shall be formed into a pocket holding a metal rod. Heavy duty plastic caps shall protect the ends of the rod. Top, front and back of case to be made of extruded aluminum powder coated white. End caps to be of heavy gauge steel, powder coated white. Bottom of case to have a removable access door. Door to be of extruded aluminum powder coated white. Bottom of case to be self-trimming, with a built-in flange around the bottom of the case. To be complete with a three-position control switch and cover plate. Suitable for use in environmental air space in accordance with section 300-22 (c) of the National Electric Code, and sections 2-128, 12-010 (3) and 12-100 of the Canadian Electrical Code, part 1, CSA C22.1. Screen to be listed by Underwriters' Laboratories.



VIDEO (NTSC 4:3) FORMAT DIMENSIONS (2" standard black drop at top)

Viewing Area		Nominal Diagonal		Overall Length of Case (does not include flange)		Approx. Ship. Wt.	
H x W	Cm	In.	Cm	In.	Cm	Lbs.	Kg
43" x 57"	109 x 145	72"	183	65½"	166	60	27.2
50" x 67"	127 x 170	84"	213	75½"	192	65	29.5
57" x 77"	145 x 196	96"	244	89½"	227	77	34.9
60" x 80"	152 x 203	100"	254	89½"	227	77	34.9
69" x 92"	175 x 234	120"	305	101½"	258	89	40.4
87" x 116"	221 x 295	150"	381	125½"	319	100	45.4
105" x 140"	267 x 356	180"	457	149½"	380	106	48.1
120" x 160"	305 x 406	200"	508	169½"	431	123	55.8

HDTV (16:9) FORMAT DIMENSIONS (2" standard black drop at top)

Viewing Area		Nominal Diagonal		Overall Length of Case (does not include flange)		Approx. Ship. Wt.	
H x W	Cm	In.	Cm	In.	Cm	Lbs.	Kg
45" x 80"	114 x 203	92"	234	89½"	227	75	34.0
52" x 92"	132 x 234	106"	269	101½"	258	88	39.9
54" x 96"	137 x 244	110"	279	105½"	268	89	40.4
58" x 104"	147 x 264	119"	302	113½"	288	95	43.1
65" x 116"	165 x 295	133"	338	125½"	319	98	44.5
78" x 139"	198 x 353	159"	404	149½"	380	104	47.2
90" x 160"	229 x 406	184"	467	169½"	431	123	55.8

16:10 WIDE FORMAT DIMENSIONS (2" standard black drop at top)

Viewing Area		Nominal Diagonal		Overall Length of Case (does not include flange)		Approx. Ship. Wt.	
H x W	Cm	In.	Cm	In.	Cm	Lbs.	Kg
50" x 80"	127 x 203	94"	239	89½"	227	75	34
60" x 96"	152 x 244	113"	287	105½"	268	89	40.4
69" x 110"	175 x 279	130"	330	119½"	304	97	44
87" x 139"	221 x 353	164"	417	149½"	380	104	47.2

SQUARE FORMAT DIMENSIONS (screens with ^ have 2" standard black drop at top)

Sizes		Overall Length of Case (does not include flange)		Approx. Ship. Wt.	
H x W	Cm	In.	Cm	Lbs.	Kg
50" x 50"	127 x 127	55½"	141	54	24.5
60" x 60"	152 x 152	65½"	166	61	27.7
70" x 70"	178 x 178	75½"	192	68	30.8
84" x 84"	213 x 213	89½"	227	79	35.8
6' x 8'^^	183 x 244	101½"	258	89	40.4
8' x 8'	244 x 244	101½"	258	91	41.3
7' x 9'^^	213 x 274	113½"	288	96	43.5
9' x 9'^^	274 x 274	113½"	288	97	44.0
8' x 10'^^	244 x 305	125½"	319	100	45.4
10' x 10'^^	305 x 305	125½"	319	102	46.3
9' x 12'^^	274 x 366	149½"	380	106	48.1
12' x 12'	366 x 366	149½"	380	119	54.0

Electrical junction box extends 2 1/8" past case length on left end of case (1 1/8" past ceiling flange). Internal junction box available (will add 3 1/2" to overall case length and must be specified at time of order, recommended for drywall installations).
 Overall case length dimensions ± 1/4" (6mm).
 Detail dimensional drawings, wiring diagrams and installation instructions available upon request.
 Specifications subject to change without notice.
 Custom formats and sizes available upon request.

- Matte White:** Seamless in all sizes.
- High Contrast Matte White:** Available in sizes where both dimensions do not exceed 10'.
- Video Spectra 1.5:** Available in sizes where both dimensions do not exceed 8'.
- High Power®:** Available in sizes up to 9' x 12'. Horizontal seam required when both dimensions exceed 6'.

WHEN ORDERING, MARK APPROPRIATE SELECTIONS:

Select size from charts above.

Select viewing surface:

- Matte White
- High Contrast Matte White
- High Power®
- Video Spectra 1.5
- Greenguard® and Greenguard® Children and Schools Certified.

Optional Accessories:

- Extra Drop available to lower picture area more than normal. Specify total drop at top _____ (black or white) or at bottom _____ (black or white). 13' maximum total surface height including picture area.
- Single Motor Low Voltage Control (LVC) - external.
- Single Motor Low Voltage Control (LVC) - built-in.
- Wireless Remote Control for LVC.
 - Radio Frequency Remote.
 - Radio Frequency Range Extender available
 - Infrared Remote.
- Silent Motor for sizes up to 9'x12'.
- Silent Motor with Integrated LVC for sizes up to 9'x12'.
- Key Locking Cover Plate for 120V or LVC Switch.
- Key Operated Switch for 120V only (NOTE: Cannot be used with LVC).

Project:	_____

Architect:	_____

Phone:	_____

Contractor:	_____

Phone:	_____

Supervisor:	_____

Phone:	_____

Supplier:	_____

Date:	_____

Revised:	_____

- No Borders (Black masking borders standard).
- 220 Volt (50 Hz) Motor.
- Video Projector Interface Control - external.
- Video Projector Interface Control - built-in (Adds 10" to case length on 220V motor only).
- SCB-100 RS-232 Serial Control Board - external.
 - NET-100 Ethernet-Serial Adapter
- SCB-100 RS-232 Serial Control Board - built-in. (adds 10" to overall length of case)
 - NET-100 Ethernet-Serial Adapter
- SCB-200 RS-232 Serial Control Board - built-in only. (adds 10" to overall length of case)
 - NET-200 Ethernet-Serial Adapter
 - WC-200 Wall Controller
 - IR-200 Infrared Remote

**ADVANTAGE® ELECTROL®
SUGGESTED METHODS OF INSTALLATION**

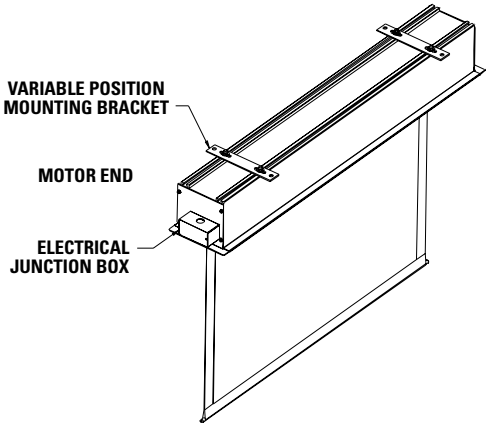
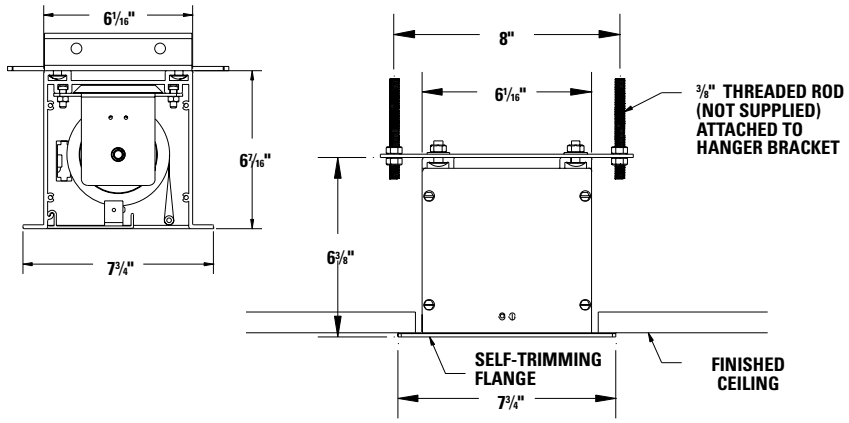

AUDIENCE SIDE

