

The Da-Lite Difference.



**Instruction Book for
TENSIONED LARGE ADVANTAGE®
ELECTROL®**



DA-LITE SCREEN COMPANY, INC.

3100 North Detroit Street
Post Office Box 137
Warsaw, Indiana 46581-0137
Phone: 574-267-8101
800-622-3737
Fax: 574-267-7804
Toll Free Fax: 877-325-4832
www.da-lite.com
e-mail: info@da-lite.com

IMPORTANT SAFETY INSTRUCTIONS

When using your video equipment, basic safety precautions should always be followed, including the following:

1. Read and understand all instructions before using.
2. Close supervision is necessary when any appliance is used by or near children. Do not leave appliance unattended while in use.
3. Do not operate appliance with a damaged cord or if the appliance has been dropped or damaged – until it has been examined by a qualified serviceman.
4. Position the cord so that it will not be tripped over, pulled, or contact hot surfaces.
5. If an extension cord is necessary, a cord with a current rating at least equal to that of the appliance should be used. Cords rated for less amperage than the appliance may overheat.
6. To reduce the risk of electric shock, do not immerse this appliance in water or other liquids.
7. To reduce the risk of electric shock, do not disassemble this appliance. Contact an authorized service dealer when repair work is required. Incorrect reassembly can cause electric shock when the appliance is used subsequently.
8. The use of an accessory attachment not recommended by the manufacturer may cause a risk of fire, electric shock, or injury to persons.

SAVE THESE INSTRUCTIONS

PRE-INSTALLATION

1. Carefully unpack screen and remove outer wrapping from case.
2. Make sure to recheck measurements of screen location before installation.

Please Note: Motor Operator Projection Screen Models LADT, LADDT, LAD and LADD must be installed in accordance with the requirements of the Local Building Codes, the Canadian Electrical Code (CEC), CAN/CSA C22.1 and the National Electric Code (NEC), NFPA 70. An appropriate disconnect device shall be provided as part of the building installation.

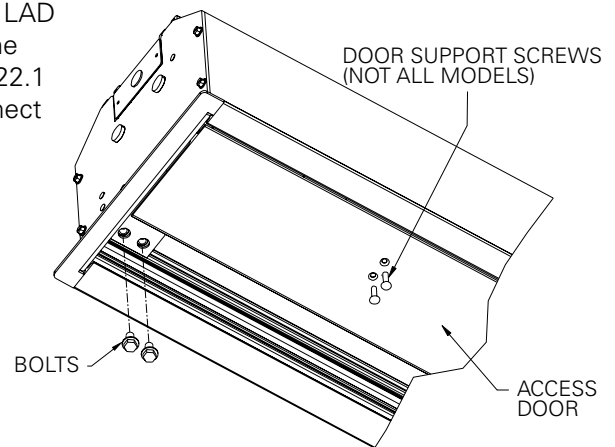

FIGURE 1

CASE INSTALLATION

1. The case provides multiple attachment points for bolts, cables, or threaded rod. Page 7 shows threaded rod installed. The variable position-mounting bracket may be located anywhere along the length of the case. It is recommended to keep the brackets spaced evenly enough to distribute the weight of the screen. One mounting bracket is required for every 4' of case length.
The case has a self-trimming flange around the bottom. Ceiling tiles or drywall may be placed on top of this flange to provide a finished appearance.
2. After securing the case in the ceiling check that the case is level and plumb.
3. Install electrical connections that apply to your unit. Review the wiring diagrams on pages 4, 5 and 6 for proper installation.

SCREEN AND ROLLER ASSEMBLY INSTALLATION

If your screen was shipped with the motor and roller already installed proceed to step 7.

1. Remove four bolts from ends of door assembly (2 bolts on each end) (Fig. 1). This will allow the door assembly to drop open for access to case. For larger sizes, you will also need to remove the door support screws.
2. Carefully unpack screen and roller assembly. Leave packing paper on the roller.
3. Remove the square peg bracket from the motor end of the roller assembly.
4. Remove the safety clip from the motor attachment bracket located in the motor end of the screen housing.
5. Place the roller assembly into the case with the motor on the left side. The limit switches should be facing down. Line up the head of the motor with the motor attachment bracket.
6. Loosen four bolts that secure pin end mounting bracket into housing. Lift pin end of roller into position and slide the bracket into the roller pin. Tighten all four bolts.
7. Complete electrical hook-up by snapping motor 1/3 wire connectors into case connectors.
8. Return to motor end and insert safety clip over casting bracket to secure motor end.



CAUTION! DO NOT CUT TAPE ON FABRIC WITH A KNIFE OR ANY SHARP TOOL. REMOVE BY HAND.

9. Carefully remove tape strips securing picture surface around roller. Slat should move freely (Fig. 2). (Only if the roller assembly is pre installed.)
10. Test installation by operating the screen several times. Be prepared to stop the screen. The door assembly will not close until the wall switch is placed in the up position and when the screen motor stops at its limit switch in the up direction.

NOTE: Unit duty cycle is 1 minute on, 3 minutes off.

NOTE: Excessive continuous operation may cause the motor to overheat. If this happens the motor will shut off until it cools to a normal operating temperature.

11. Close door assembly and replace four bolts at ends of door (2 bolts on each end) (Fig. 1).

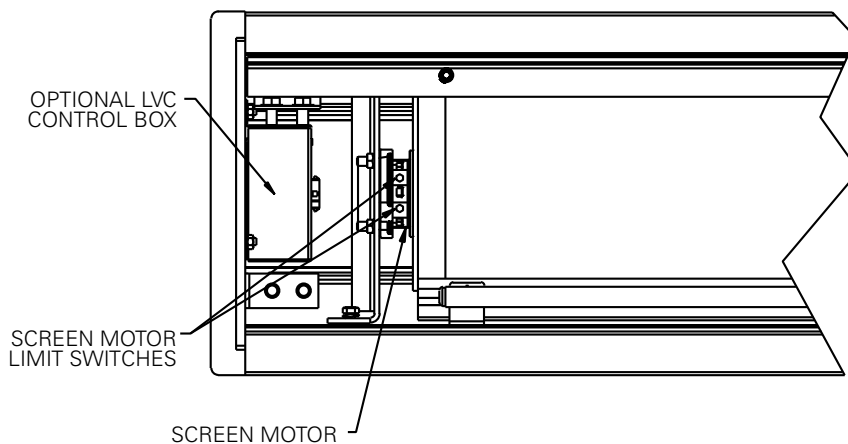

FIGURE 2

SCREEN ADJUSTMENT

Surface travel is stopped automatically in the fully opened and closed positions by limit switches that are properly adjusted at Da-Lite. Should it be necessary to adjust for more or less drop of picture, proceed in the following manner:

NOTE: Use a screw driver or 5/32" Allen wrench to make adjustments.

MORE SCREEN DROP

1. Place operating switch in "**down**" position.
2. When the screen stops, turn the white "**down**" limit knob (Fig. 2) one-quarter turn counterclockwise. Test by raising picture surface approximately two feet, then lower again. Repeat until desired picture surface position is attained.



CAUTION: Do not adjust for more drop than what was ordered. At least 1-1/2 wraps of fabric must remain on the roller. This screen comes standard with 0" or 2" black at the top. See the specification data sheet for details.

LESS SCREEN DROP

1. Raise picture surface approximately two feet above desired level.
2. Place operating switch in "**off**" position.
3. Turn the white "**down**" limit switch (Fig. 2) one-quarter turn clockwise. Test by raising picture surface approximately two feet, then lower again. Repeat until desired picture surface position is attained.

120V WIRING DIAGRAM

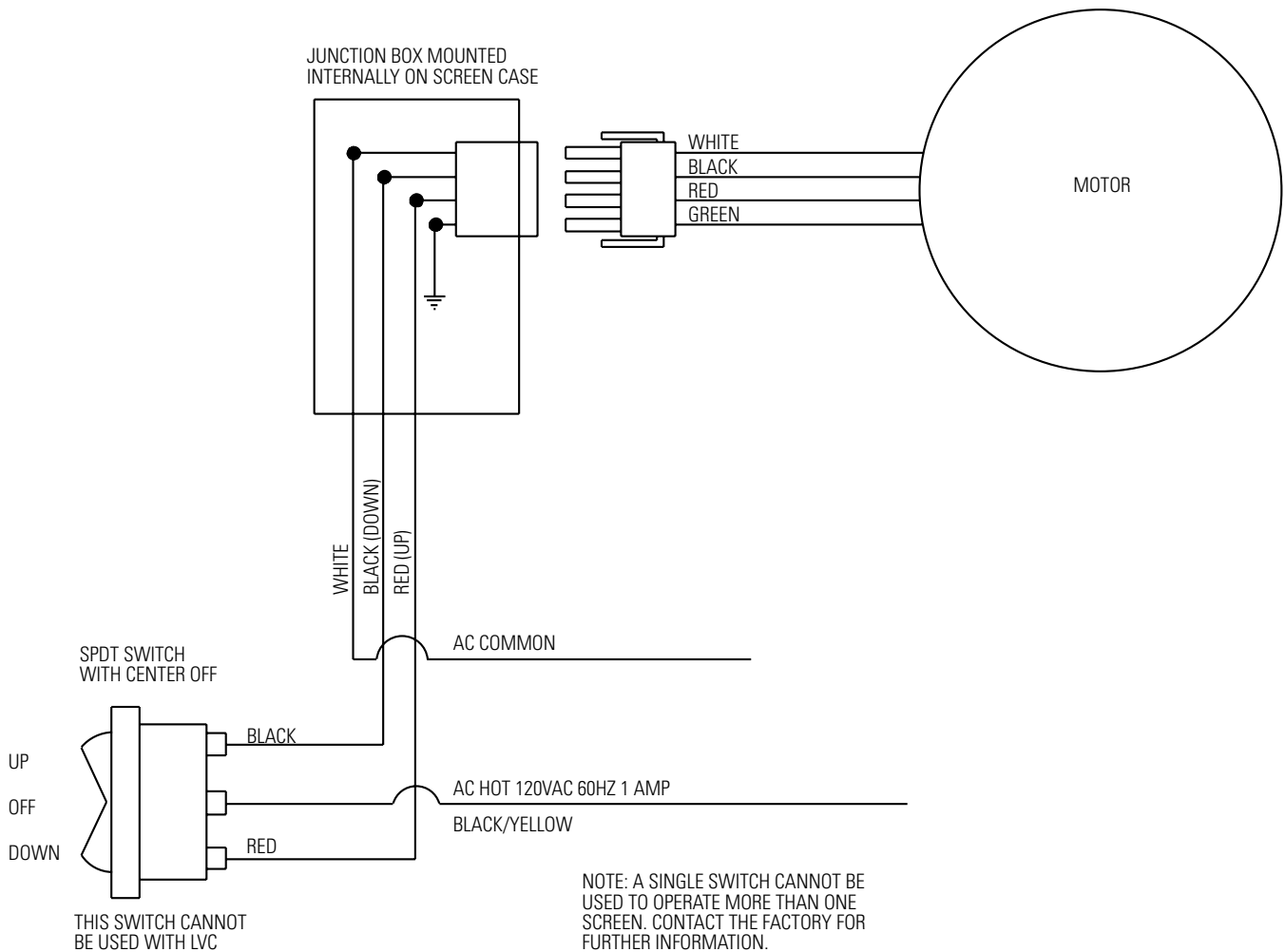

240 VOLT WIRING DIAGRAM FOR STANDARD WALL SWITCH:

Da-Lite offers two styles of 240 volt wall switches for standard operation. Please see wiring diagram included in wall switch box included with screen.

**120V WIRING DIAGRAM
WITH OPTIONAL BUILT-IN
LOW VOLTAGE CONTROL**

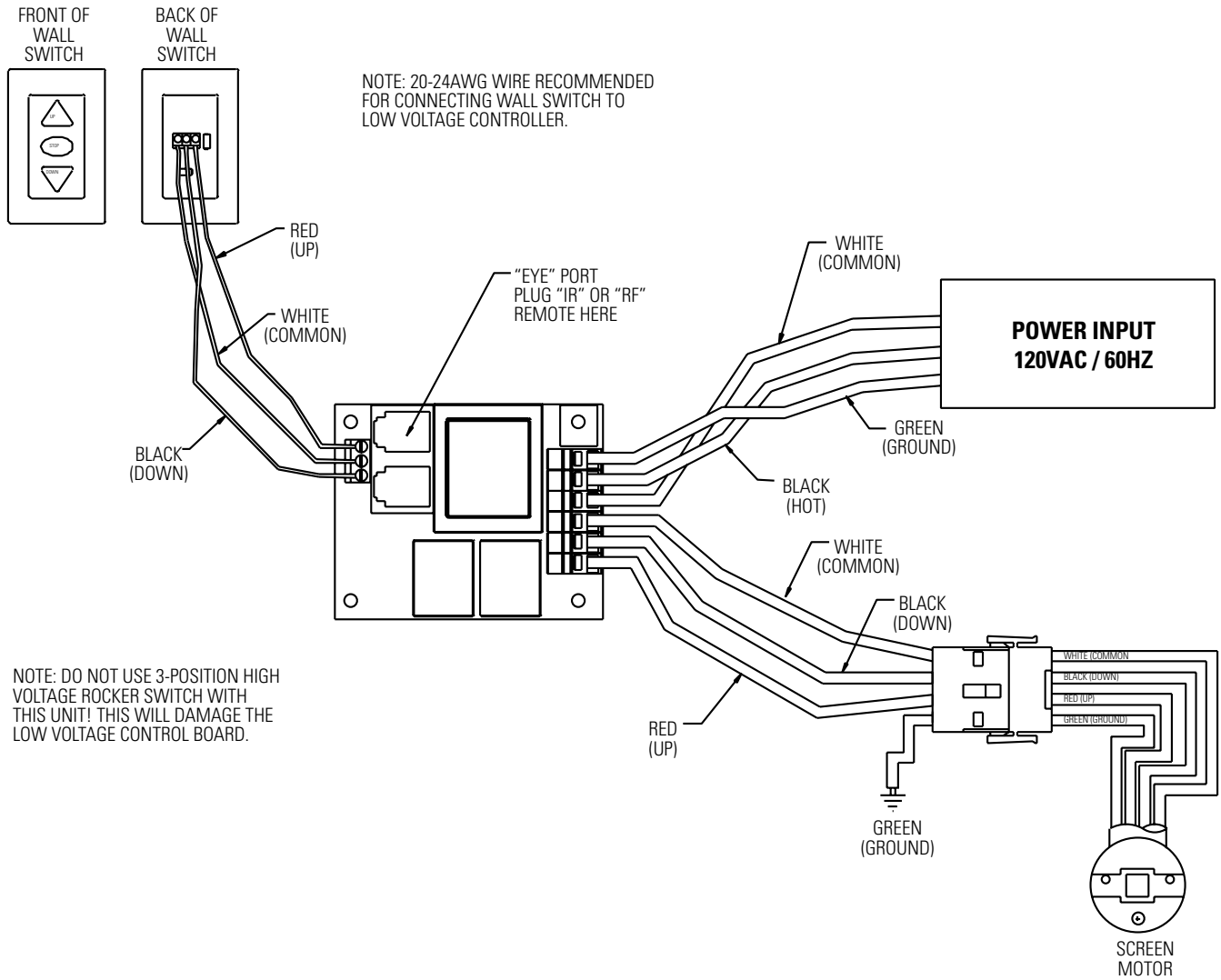

**240V WIRING DIAGRAM
WITH OPTIONAL BUILT-IN
LOW VOLTAGE CONTROL**

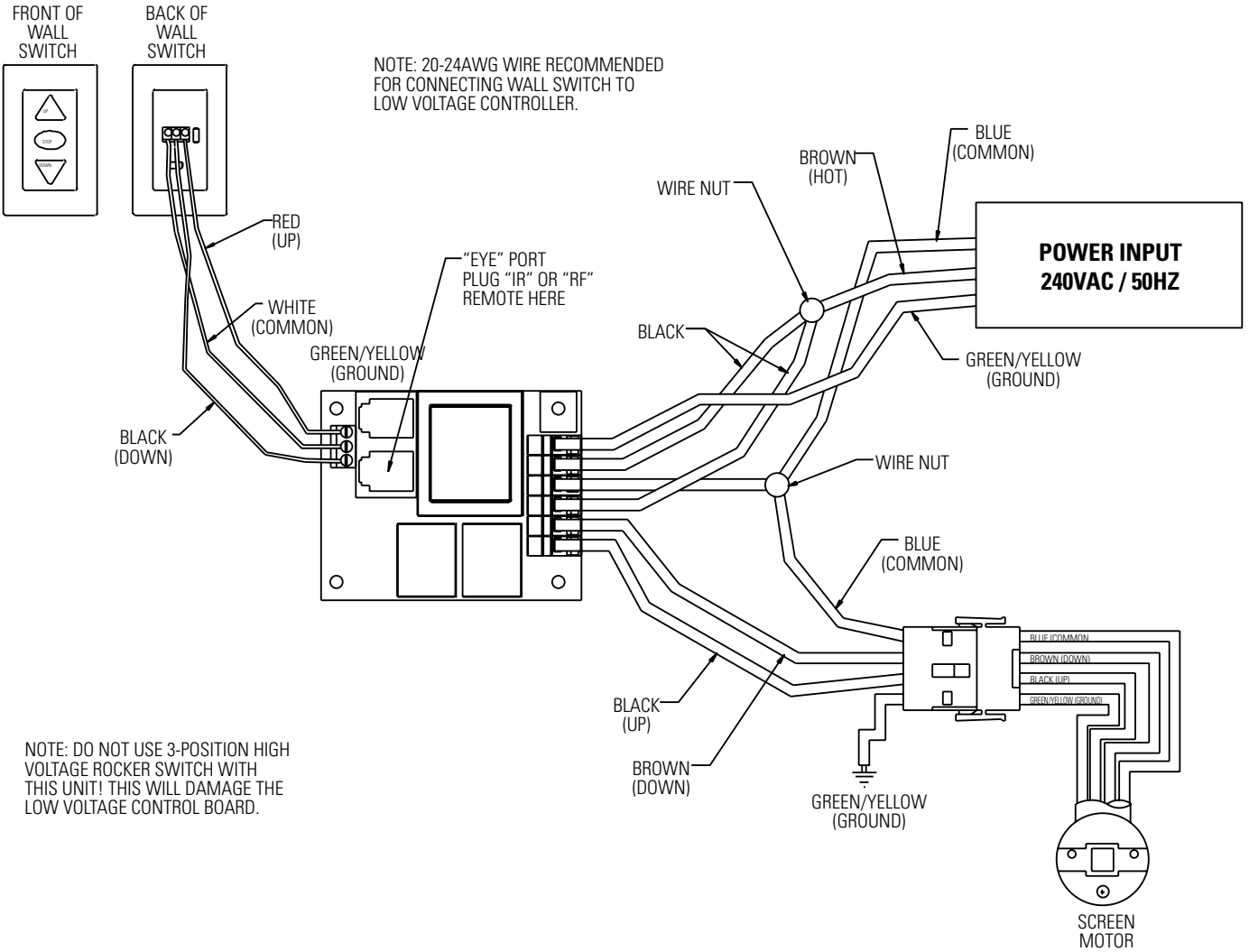

TENSIONED LARGE ADVANTAGE® ELECTROL® INSTALLATION

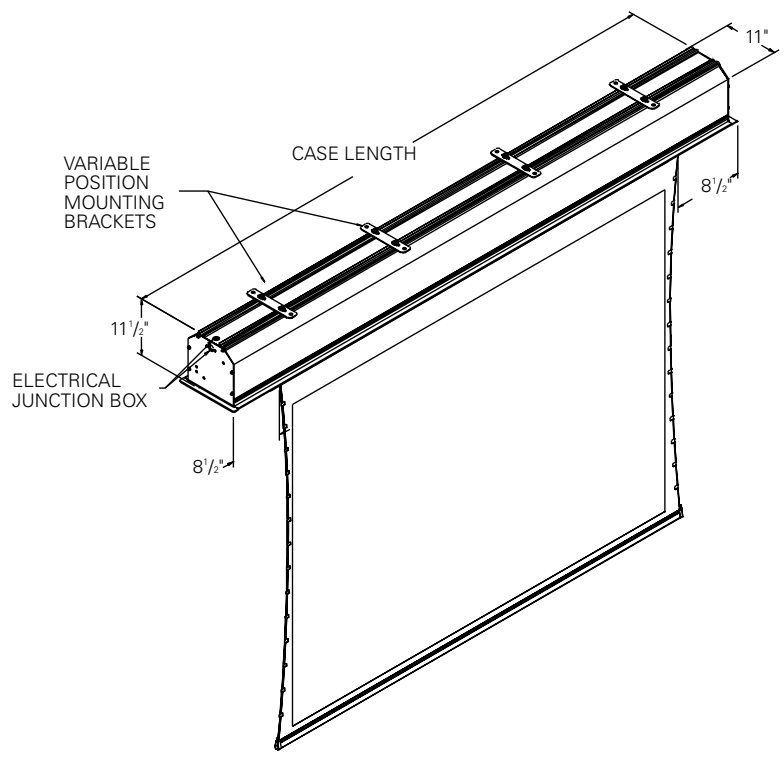
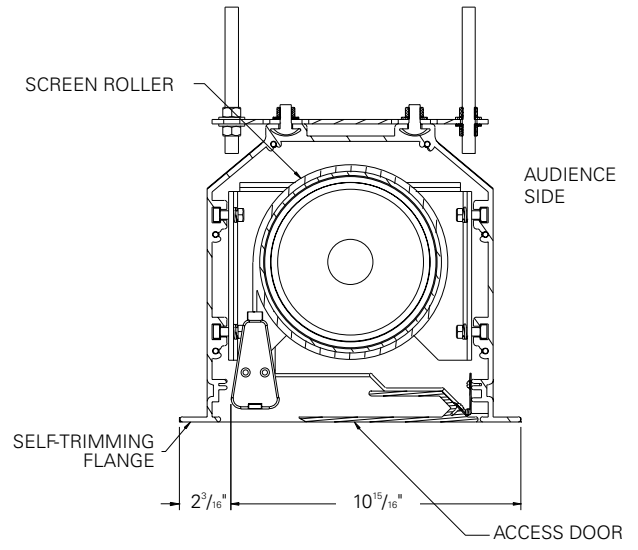
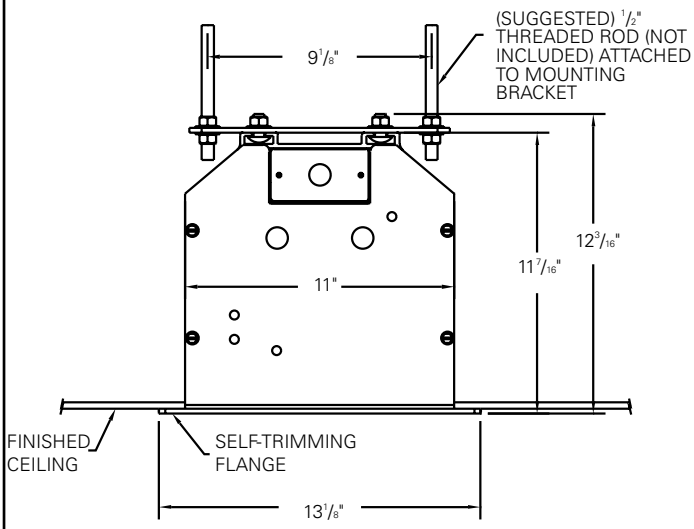

TROUBLESHOOTING

Visit www.da-lite.com/products/tutorials.php to find installation and troubleshooting tutorials. You will also find a link to Live Chat for interactive support and you can contact us by email at info@da-lite.com or by phone at (800) 622-3737 or (574) 267-8101 with any troubleshooting questions.

SYMPTOM	CAUSE	SOLUTION
<p>1. Screen will not operate or will not go "down". Motor does not hum.</p> <p>Motor hums.</p>	<p>(a) Incorrect line voltage.</p> <p>(b) Blown facility fuse.</p> <p>(c) Tripped facility circuit breaker.</p> <p>(d) No power to operating switch or junction box.</p> <p>(e) Low voltage board has no power or blown transformer.</p> <p>Power at junction box.</p> <p>(f) Thermal overload tripped.</p> <p>(g) Broken wire in the "down" position.</p> <p>(h) Defective motor, limit switch or capacitor.</p> <p>(i) Capacitor burned out.</p>	<p>(a) Verify 115-125V (or 220-240V). If insufficient voltage, rewire incoming electric line.</p> <p>(b) Replace facility fuse.</p> <p>(c) Reset facility circuit breaker.</p> <p>(d) Check above. Tighten all loose wire connections. Recheck wiring. See installation instructions.</p> <p>(e) Replace low voltage board.</p> <p>"Down" Position Check for power across black and white leads.</p> <p>(f) Let motor cool down for 15 minutes. Try again.</p> <p>(g) Check for continuity.</p> <p>(h) Replace motor assembly. NOTE: Motor is a sealed assembly.</p> <p>(i) Replace motor assembly.</p>
<p>2. Screen will not move upward. Motor does not hum.</p> <p>Motor hums.</p>	<p>(a) Incorrect line voltage.</p> <p>(b) Blown facility fuse.</p> <p>(c) Tripped facility circuit breaker.</p> <p>(d) No power to operating switch or junction box.</p> <p>(e) Low voltage board has no power or blown transformer.</p> <p>Power at junction box</p> <p>(g) Thermal overload tripped.</p> <p>(h) Broken wire in the "up" position.</p> <p>(i) Defective motor, limit switch or capacitor.</p> <p>(j) Capacitor burned out.</p>	<p>(a) Verify 115-125V (or 220-240V). If insufficient voltage, rewire incoming electric line.</p> <p>(b) Replace facility fuse.</p> <p>(c) Reset facility circuit breaker.</p> <p>(d) Check above. Tighten all loose wire connections. See above.</p> <p>(e) Replace low voltage board.</p> <p>"Up" Position Check for power across red and white leads.</p> <p>(g) Let motor cool down for 15 minutes. Try again.</p> <p>(h) Check for continuity.</p> <p>(i) Replace motor assembly. NOTE: Motor is a sealed assembly.</p> <p>(j) Replace motor assembly.</p>

TROUBLESHOOTING

SYMPTOM	CAUSE	SOLUTION
3. "Down" limit switch incorrect.	(a) "Down" limit switch out of adjustment.	(a) See installation instructions.
4. Noise. NOTE: Screen will operate with a low-pitched hum.	(a) Buzzing noise. (b) Gear noise.	(a) Adjust door limit switch (too far down). (b) Replace motor assembly.
5. Coasting.	(a) Defective brake.	(a) Replace motor assembly.
6. Roller displaced from mounting bracket.	(a) Pin end slipped out of nylon bearing.	(a) Realign pin end bracket.
7. Fabric hangs crooked.	(a) Screen not installed properly. (b) Fabric is damaged.	(a) Check for level and plumb. (b) Replace fabric.

THIS PAGE IS INTENTIONALLY LEFT BLANK

**LIMITED ONE YEAR WARRANTY
ON DA-LITE PRESENTATION PRODUCTS**

Da-Lite Screen Company, Inc. warrants its products to the original purchaser only, to be free from defects in materials and workmanship for a period of one (1) year from the date of purchase by the original purchaser provided they are properly operated according to Da-Lite's instructions and are not damaged due to improper handling or treatment after shipment from the factory.

This warranty does not apply to equipment showing evidence of misuse, abuse or accidental damage, or which has been tampered with or repaired by a person other than authorized Da-Lite personnel.

Da-Lite's sole obligation under this warranty shall be to repair or to replace (at Da-Lite's option) the defective part of the merchandise. Returns for service should be made to your Da-Lite dealer. If it is necessary for the dealer to return the screen or part to Da-Lite, transportation expenses to and from Da-Lite are payable by the purchaser and Da-Lite is not responsible for damage in shipment. To protect yourself against damage or loss in transit, insure the product and prepay all transportation expenses.

THIS WARRANTY IS IN LIEU OF ALL OTHER WARRANTIES, EXPRESS OR IMPLIED, INCLUDING WARRANTIES AS TO FITNESS FOR USE AND MERCHANT ABILITY. Any implied warranties of fitness for use, or merchantability, that may be mandated by statute or rule of law are limited to the one (1) year warranty period. This warranty gives you specific legal rights, and you may also have other rights, which vary from state-to-state. **NO LIABILITY IS ASSUMED FOR EXPENSES OR DAMAGES RESULTING FROM INTERRUPTION IN OPERATION OF EQUIPMENT, OR FOR INCIDENTAL, DIRECT, OR CONSEQUENTIAL DAMAGES OF ANY NATURE.**

In the event that there is a defect in materials or workmanship of a Da-Lite product, you may contact our Sales Partners at PO Box 137, Warsaw, IN 46581-0137, (574) 267-8101, (800) 622-3737.

IMPORTANT: THIS WARRANTY SHALL NOT BE VALID AND DA-LITE SHALL NOT BE BOUND BY THIS WARRANTY IF THE PRODUCT IS NOT OPERATED IN ACCORDANCE WITH DA-LITE'S WRITTEN INSTRUCTIONS.

Keep your sales receipt to prove the date of purchase and your original ownership.