

# User Manual

020-001213-02

## GS Series

**DHD630-GS / DWU630-GS**

**DHD635-GS / DWU635-GS**

**CHRISTIE®**

**The USB included with this printed manual contains an electronic copy in English. Please read all instructions before using or servicing this product.**

手册中包含的 U 盘，带有着中文的电子副本，使用或维修本产品前，请仔细阅读所有的指示。

**Le clé USB fourni avec ce manuel imprimé contient une copie électronique en français. S'il vous plaît lire toutes les instructions avant d'utiliser ou de réparer ce produit.**

**Das USB, das mit diesem gedruckten Handbuch eingeschlossen ist, enthält eine elektronische Kopie auf in deutscher Sprache. Vor der Anwendung oder der Instandhaltung dieses Produktes lesen Sie bitte alle Anweisungen.**

**Il USB fornito con il manuale stampato contiene una copia elettronica in lingua italiano. Si prega di leggere tutte le istruzioni prima di utilizzare o riparare questo prodotto.**

この印刷されたマニュアルに同梱されております USB には、日本語での説明書が入っております。この製品を使用あるいは修理点検される際に、ご参照下さい。

**매뉴얼과 함께 포함되어 있는 USB 에는 한글로 된 전자사본을 포함하고 있습니다 . 본 제품을 사용 혹은 서비스하기 전에 모든 지침 사항들을 읽어 보시기 바랍니다 .**

Поставляемый в комплекте с документацией USB содержит электронную копию руководства пользователя на русском языке. Перед началом использования изделия или проведения сервиса пожалуйста прочтите все инструкции изложенные в руководстве.

**El USB incluido con este manual impreso contiene una copia electrónica en español. Por favor, lea todas las instrucciones antes de usar o dar servicio a este producto.**

USB, що постачається з цим друковане керівництво містить електронну копію українською мовою. Будь ласка, прочитайте всі інструкції перед використанням або обслуговуванням цього продукту.

**O USB incluído com o impresso livro contém um eletrônico cópia em Português. Por favor lido todas as instruções antes de usar ou prestando serviço esse resultado.**

## NOTICES

### COPYRIGHT AND TRADEMARKS

Copyright © 2018 Christie Digital Systems USA Inc. All rights reserved.

All brand names and product names are trademarks, registered trademarks or trade names of their respective holders.

### GENERAL

Every effort has been made to ensure accuracy, however in some cases changes in the products or availability could occur which may not be reflected in this document. Christie reserves the right to make changes to specifications at any time without notice. Performance specifications are typical, but may vary depending on conditions beyond Christie's control such as maintenance of the product in proper working conditions. Performance specifications are based on information available at the time of printing. Christie makes no warranty of any kind with regard to this material, including, but not limited to, implied warranties of fitness for a particular purpose. Christie will not be liable for errors contained herein or for incidental or consequential damages in connection with the performance or use of this material. Canadian manufacturing facility is ISO 9001 and 14001 certified.

### WARRANTY

Products are warranted under Christie's standard limited warranty, the complete details of which are available by contacting your Christie dealer or Christie. In addition to the other limitations that may be specified in Christie's standard limited warranty and, to the extent relevant or applicable to your product, the warranty does not cover:

- a. Problems or damage occurring during shipment, in either direction.
- b. Problems or damage caused by combination of a product with non-Christie equipment, such as distribution systems, cameras, DVD players, etc., or use of a product with any non-Christie interface device.
- c. Problems or damage caused by misuse, improper power source, accident, fire, flood, lightning, earthquake, or other natural disaster.
- d. Problems or damage caused by improper installation/alignment, or by equipment modification, if by other than Christie service personnel or a Christie authorized repair service provider.
- e. Problems or damage caused by use of a product on a motion platform or other movable device where such product has not been designed, modified or approved by Christie for such use.
- f. Except where the product is designed for outdoor use, problems or damage caused by use of the product outdoors unless such product is protected from precipitation or other adverse weather or environmental conditions and the ambient temperature is within the recommended ambient temperature set forth in the specifications for such product.
- g. Defects caused by normal wear and tear or otherwise due to normal aging of a product.

The warranty does not apply to any product where the serial number has been removed or obliterated. The warranty also does not apply to any product sold by a reseller to an end user outside of the country where the reseller is located unless (i) Christie has an office in the country where the end user is located or (ii) the required international warranty fee has been paid.

The warranty does not obligate Christie to provide any on site warranty service at the product site location.

### PREVENTATIVE MAINTENANCE

Preventative maintenance is an important part of the continued and proper operation of your product. Failure to perform maintenance as required, and in accordance with the maintenance schedule specified by Christie, will void the warranty.

### REGULATORY

The product has been tested and found to comply with the limits for a Class A digital device, pursuant to Part 15 of the FCC Rules. These limits are designed to provide reasonable protection against harmful interference when the product is operated in a commercial environment. The product generates, uses, and can radiate radio frequency energy and, if not installed and used in accordance with the instruction manual, may cause harmful interference to radio communications. Operation of the product in a residential area is likely to cause harmful interference in which case the user will be required to correct the interference at the user's own expense.

#### CAN ICES-3 (A) / NMB-3 (A)

이 기기는 업무용 (A 급) 으로 전자파적합등록을 한 기기이오니 판매자 또는 사용자는 이점을 주의하시기 바라며, 가정 외의 지역에 서 사용하는 것을 목적으로 합니다.

### Environmental

The product is designed and manufactured with high-quality materials and components that can be recycled and reused. **This symbol**  means that electrical and electronic equipment, at their end-of-life, should be disposed of separately from regular waste. Please dispose of the product appropriately and according to local regulations. In the European Union, there are separate collection systems for used electrical and electronic products. Please help us to conserve the environment we live in!

# Content

<b>Safety</b> .....	<b>8</b>
Laser safety warnings .....	9
<b>Introduction</b> .....	<b>10</b>
Projector components .....	10
Front view .....	10
Rear view .....	11
Left view .....	12
Right view .....	12
Built-in keypad .....	13
Input/Output (I/O) panel .....	14
DWU630-GS/DHD630-GS Series .....	14
DWU635-GS/DHD635-GS Series .....	15
IR remote keypad .....	16
LED status indicators .....	18
Light LED .....	18
Status LED .....	18
Picture Mute LED .....	18
<b>Installation</b> .....	<b>19</b>
Connecting to a computer .....	19
DWU630-GS/DHD630-GS Series .....	19
DWU635-GS/DHD635-GS Series .....	20
Connecting to video equipment .....	21
DWU630-GS/DHD630-GS Series .....	21
DWU635-GS/DHD635-GS Series .....	22
Turning the projector on .....	23
Turning the projector off .....	24
Adjusting the projector position .....	24
Calculating the lens offset .....	25
WUXGA projectors .....	25
HD Projectors .....	27
Removing and installing the lens .....	30
Installing the cable cover .....	31
Installing the ceiling mount .....	31
Rotating the Christie badge .....	32

<b>Operation .....</b>	<b>33</b>
Picture menu .....	34
HSG Adjustment .....	37
Image blending .....	39
Screen menu .....	40
Geometry Correction .....	43
PIP/PBP Settings menu .....	44
PIP/PBP layout and size .....	46
Settings Menu .....	47
Language menu .....	49
Test Pattern menu .....	49
Light Source menu .....	50
Options Menu .....	51
Information menu .....	53
3D menu .....	55
Communications menu .....	56
LAN settings .....	58
Web user interface .....	59
Logging on to the web user interface .....	59
Main tab–General .....	60
Main tab–Status .....	60
Main tab–Lens .....	61
Network .....	62
Tools .....	64
Administrator Page .....	64
About Page .....	65
<b>Troubleshooting .....</b>	<b>66</b>
No image appears on screen .....	66
Incorrectly displayed image .....	66
Presentation is not displayed .....	67
Unstable or flickering images .....	68
Vertical flickering bar .....	68
Image is out of focus .....	68
Image is stretched .....	68
Image is not the correct size .....	69
Connection fail when DHCP on .....	69
Connection fail with new IP address .....	70

<b>Specifications .....</b>	<b>71</b>
Inputs .....	71
PIP/PBP compatibility .....	75
Key features .....	76
List of components .....	77
Physical specifications .....	78
Physical operating environment .....	78
Power requirements .....	79
Regulatory .....	79
Safety .....	79
Laser Safety .....	79
Electro-Magnetic Compatibility .....	80
Environmental .....	80
Marking .....	80
Federal Communications Commission (FCC) warning .....	80
On-screen display tree .....	81

# Safety

Read through this document in its entirety and understand all warnings and precautions before attempting to operate the projector.



**Warning!** Failure to comply with the following could result in death or serious injury.

- Do not look into the projector lens when the laser is on. The bright light may result in permanent eye damage.
- To reduce the risk of fire or electric shock, do not expose this projector to rain or moisture.
- Do not open or disassemble the projector as this may cause electric shock.
- When you turn the projector off, wait 180 seconds for the projector to cool down before you disconnect the projector from power.
- All installation and maintenance procedures must be performed by a Christie accredited service technician.
- Keep all combustible material away from the concentrated light beam of the projector.
- Position all cables where they cannot contact hot surfaces or be pulled or tripped over.
- Always power down the projector and disconnect all power sources before servicing or cleaning.
- Use a soft cloth moistened with a mild detergent to clean the display housing.
- Disconnect the power plug from the AC outlet if the product is not being used for an extended period of time.
- Use only the AC power cord supplied. Do not attempt operation if the AC supply and cord are not within the specified voltage and power range for your region.
- Remove the lens plug from the lens opening in the projector before installing the lens. Retain the lens plug to protect the optical components from dust and debris during transport.
- Do not block the ventilation slots and openings on the projector.
- Do not use abrasive cleaners, waxes or solvents to clean the projector.
- Do not allow anything to rest on the power cord.

# Laser safety warnings

This product is classified as CLASS 1 LASER PRODUCT - RISK GROUP 2 according to IEC 60825-1 : 2014 complies with FDA regulations 21 CFR 1040.10 and 1040.11 as a Risk Group 2 , LIP ( Laser Illuminated Projector) as defined in IEC 62471:2006 except for deviations pursuant to Laser Notice No. 50, dated June 24, 2007.

 <p>Complies with 21 CFR 1040.10 and 1040.11 as a Risk Group 2, LIP (Laser Illuminated Projector) as defined in IEC 62471:2006 except for deviations pursuant to Laser Notice No. 50, dated June 24, 2007</p>				
<p>IEC 60825-1:2014 CLASS 1 LASER PRODUCT RISK GROUP 2</p>	<p>IEC 60825-1:2014 PRODUIT LASER DE CLASSE 1 GROUPE DE RISQUE 2</p>	<p>IEC 60825-1:2014 1类激光产品 危险组2</p>	<p>IEC 60825-1:2014 1등급 레이저 제품 위험 그룹 2</p>	<p>IEC 60825-1:2014 クラス1レーザー製品 リスクグループ 2</p>
<p><b>CAUTION</b> Possibly hazardous optical radiation emitted from this product. Do not stare at beam. May be harmful to the eye.</p>	<p><b>AVERTISSEMENT</b> Radiation optique à danger potentiel émise par ce produit. Ne regardez pas directement le faisceau laser. Ceci pourrait être nocif pour votre œil.</p>	<p><b>注意</b> 此产品可能会产生危险光辐射。请勿直视操作光束，以免对眼睛损害。</p>	<p><b>주의</b> 이 제품으로부터 인체에 위험한 광선이 방사될 수 있음. 광원을 정면으로 바라보지 마시오. 눈에 심각한 손상을 입을 수 있음.</p>	<p><b>注意</b> 本製品より危険となりうる光放射あり。ビームをのぞき込まないこと。眼に有害となる可能性あり。</p>



**Warning!** Failure to comply with the following could result in death or serious injury.

- This projector has a built-in Class 4 laser module. Never attempt to disassemble or modify the projector.
- Any operation or adjustment not specifically instructed in the User manual creates the risk of hazardous laser radiation exposure.
- Do not open or disassemble the projector as this may cause damage or exposure to laser radiation.
- Do not stare into beam when the projector is on. The bright light may result in permanent eye damage.
- When turning on the projector, make sure no one within projection range is looking into the lens.
- Follow the control, adjustment, or operation procedures to avoid damage or injury from exposure of laser radiation.
- The instructions for the assembly, operation, and maintenance include clear warnings concerning precautions to avoid possible exposure to hazardous laser radiation.



# Introduction

The product specified in this document is a high brightness, high-resolution video/graphics 1-chip laser based projector. The projector is available in HD and WUXGA resolutions. The projector utilizes Digital Light Processing (DLP®) technology from Texas Instruments. It is primarily designed for fixed installation markets.

## Projector components

Identify the main components of the projector.

### Front view

Identify the main components on the front of the projector.

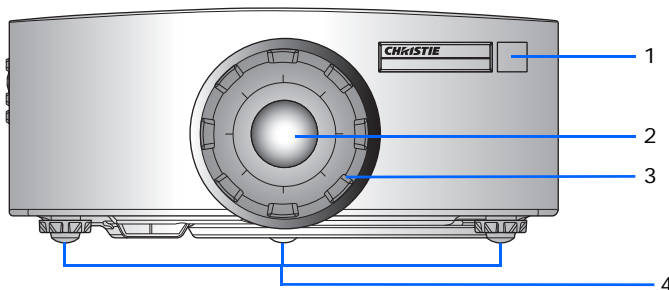

ID	Part name	Description
1	Front IR sensors	Receives signals from the IR remote keypad. Keep the signal path to the sensor unobstructed for uninterrupted communication with the projector.
2	Projection lens	Allows automated lens control and adjustment: vertical and horizontal offsets, zoom, and focus.
3	Lens ring	Protects the lens motors and mechanism. Remove in order to insert or remove the lens.
4	Adjustable feet	Raises or lowers the feet to level the projector.

## Rear view

Identify the main components on the rear of the projector.

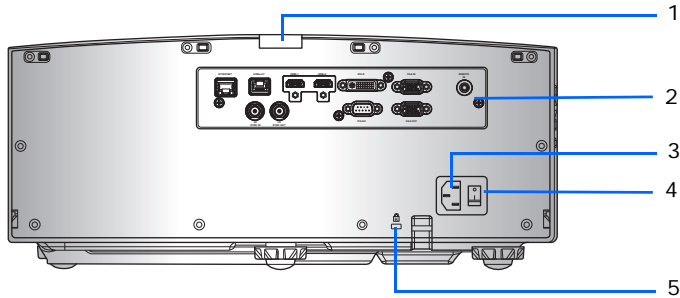

ID	Part name	Description
1	Rear IR sensor	Receives signals from the IR remote keypad. Keep the signal path unobstructed for uninterrupted communication with the projector.
2	Input/Output (I/O) panel	Connects the projector to external devices.
3	AC input	Connects to the supplied power adapter (100-240V~).
4	Power button	Powers the projector on or off.
5	Kensington security slot	Secures the projector to help prevent theft or unauthorized removal.

## Left view

Identify the main components on the left side of the projector.

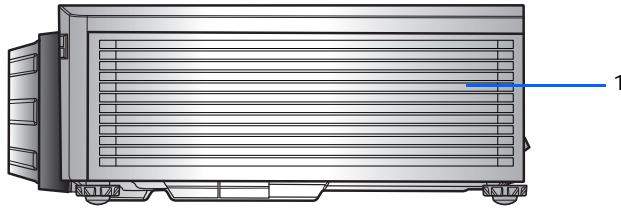

ID	Part name	Description
1	Cooling air vents (intake)	Provides cooling to the projector. Keep these vents unobstructed to prevent the projector from overheating.

## Right view

Identify the main component on the right side of the projector.

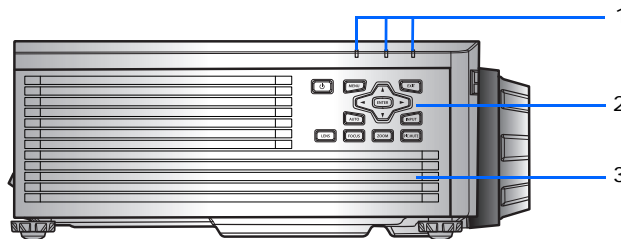

ID	Part name	Description
1	LED Status Indicators	Displays the status of the projector. They are (from left to right): LIGHT, STATUS, and PICTURE MUTE.
2	Built-in keypad	Controls the projector.
3	Cooling air vents (exhaust)	Provides cooling to the projector. Keep these vents unobstructed to prevent the projector from overheating.

## Built-in keypad

The built-in keypad controls the projector.

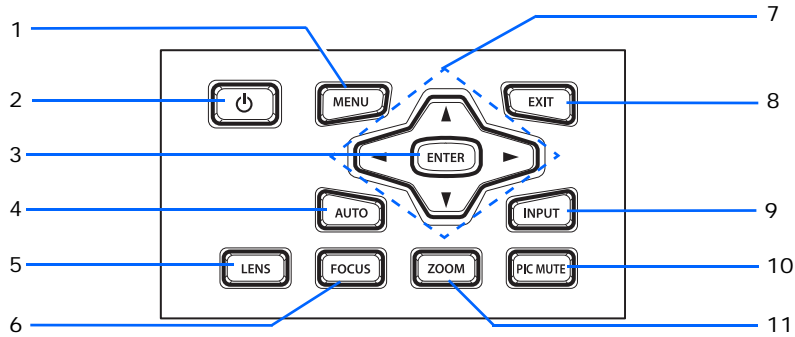

ID	Part name	Description
1	Menu	Displays the menus.
2	Power	Turns the projector on or off.
3	Enter	Confirms a selection.
4	Auto	Automatically optimizes an image.
5	Lens	Adjusts the lens vertical or horizontal offset setting.
6	Focus	Adjusts the focus.
7	Arrow keys	Adjusts a setting up or down, or navigate within a menu.
8	Exit	Returns to the previous level or exits the menus if at top level.
9	Input	Selects an input for the main or PIP/PBP image.
10	Picture mute	Displays or blanks the video image.
11	Zoom	Adjusts the zoom.

# Input/Output (I/O) panel

Identify the components of the Input/Output (I/O) panel.

## DWU630-GS/DHD630-GS Series

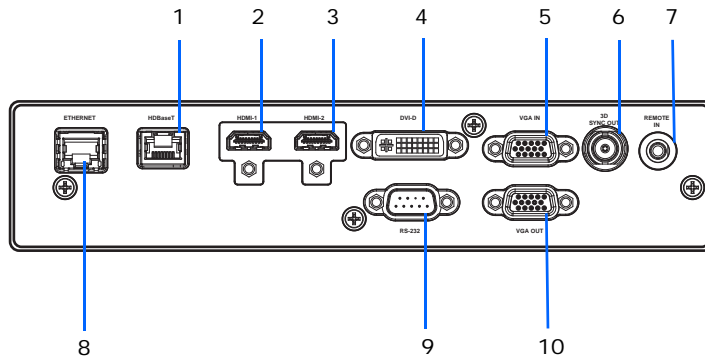

ID	Connector name	ID	Connector name
1	HDBaseT	6	3D SYNC OUT
2	HDMI-1	7	REMOTE IN
3	HDMI-2	8	ETHERNET (LAN)
4	DVI-D	9	RS-232
5	VGA IN	10	VGA OUT

## DWU635-GS/DHD635-GS Series

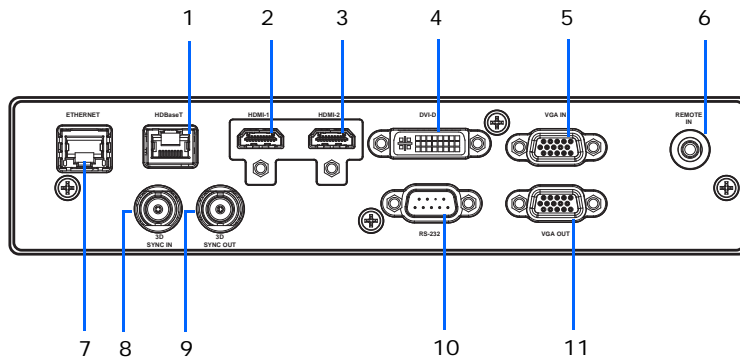

ID	Connector name	ID	Connector name
1	HDBaseT	7	ETHERNET (LAN)
2	HDMI-1	8	3D SYNC IN
3	HDMI-2	9	3D SYNC OUT
4	DVI-D	10	RS-232
5	VGA IN	11	VGA OUT
6	REMOTE IN		

# IR remote keypad

The IR remote keypad communicates with the projector by way of wireless communications. Use a cable length of 20 m or less. If the length of cable exceeds 20 m, the IR remote keypad may not work correctly.

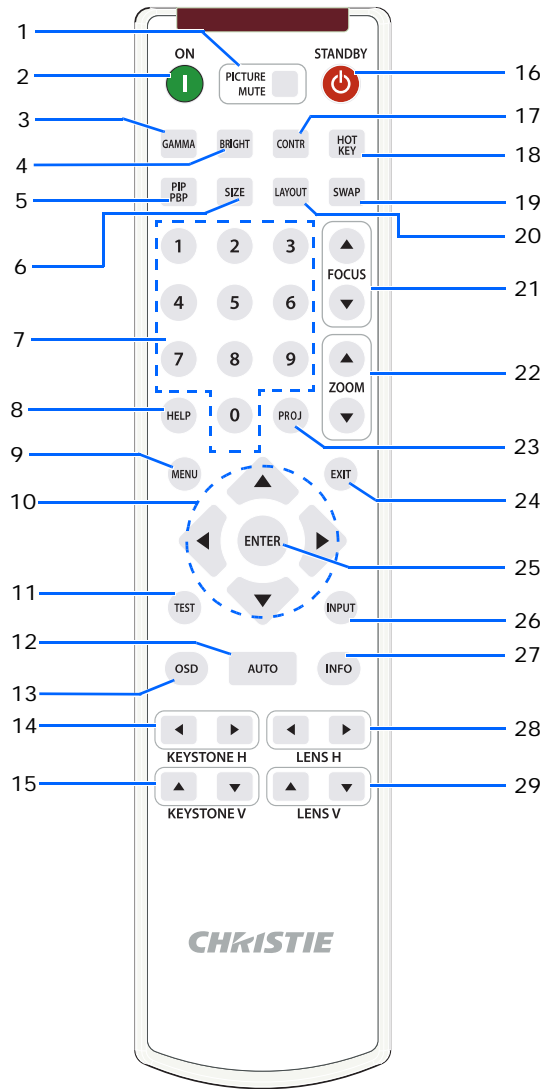

ID	Button	Description
1	PICTURE MUTE	Displays or blanks the video image.
2	ON	Turns the projector on.
3	GAMMA	Adjusts the mid-range levels.
4	BRIGHT	Adjusts the amount of light in the image.
5	PIP/PBP	Turns PIP/PBP on or off.

<b>ID</b>	<b>Button</b>	<b>Description</b>
6	SIZE	Adjusts the PIP/PBP size.
7	Number Keys	Enters a number, such as a channel, value, and so on. The on-screen display indicates if a function is not supported.
8	HELP	Displays the instructions for source connection.
9	MENU	Displays the menus.
10	Arrow Keys	Adjusts a setting up or down to navigate within a menu.
11	Test	Displays a test pattern.
12	AUTO	Automatically optimizes an image.
13	OSD	Uses to hide or shows on-screen display (OSD) menus.
14	KEystone H	Adjusts the horizontal keystone.
15	KEystone V	Adjusts the vertical keystone.
16	STANDBY	Turns the projector off.
17	CONTR	Adjusts the difference between dark and light.
18	HOT KEY	Selects your preset key quickly.
19	SWAP	Swaps the main and PIP/PBP images.
20	LAYOUT	Adjusts the PIP/PBP layout.
21	FOCUS	Adjusts the focus to improve image clarity as required.
22	ZOOM	Adjusts the zoom to achieve a required image size.
23	PROJ	Changes the IR remote keypad ID. <ul style="list-style-type: none"> <li>• To assign an ID, press <b>Proj</b> + &lt;1 to 9&gt;.</li> <li>• To return to the universal IR remote ID, press <b>Proj</b> + <b>0</b>.</li> </ul>
24	EXIT	Returns to previous level or exit menus if at top level.
25	ENTER	Selects a highlighted menu item, or changes or accepts a value.
26	INPUT	Selects an input for the main or PIP/PBP image.
27	INFO	Displays the source image information.
28	LENS H	Adjusts the position of the image horizontally.
29	LENS V	Adjusts the position of the image vertically.



## LED status indicators

LEDs are defined below.

### Light LED

Identify the laser diode state colors and meaning.

LED status	Projector state
Red (flashing)	Projector has lost over 60% initial luminance.
Orange (solid)	Laser diode time has expired.
Green (solid)	Laser diode is on and operating correctly.
Off	Laser diode is off.

### Status LED

Identify the LED state colors and meaning.

LED status	Projector state
Off	AC power is off (without AC plugged in).
Off, but keypad LED is on	AC has been applied, projector is in standby mode. NOTE: Status LED cannot be flashing red, as this is reserved for an error condition. Status LED is off but keypad LED will indicate Standby Mode.
Green (solid)	Projector is powered up and operating normally.
Green (flashing)	Projector communications.
Orange (flashing)	Projector is in cool down mode or startup mode.
Green (flashing) / Orange (solid)	Projector is in flash update state.
Red (solid)	Over-temperature.
Red (flashing)	Fan failure.

### Picture Mute LED

Identify the picture mute LED state colors and meaning.

LED status	Projector state
Green (solid)	Light is on and an image is displayed.
Orange (solid)	Light is on and the image is blank.

# Installation

Learn how to install, connect, and optimize the projector display.

## Connecting to a computer

Learn what cables/connectors that may be used to connect to various devices.

### DWU630-GS/DHD630-GS Series

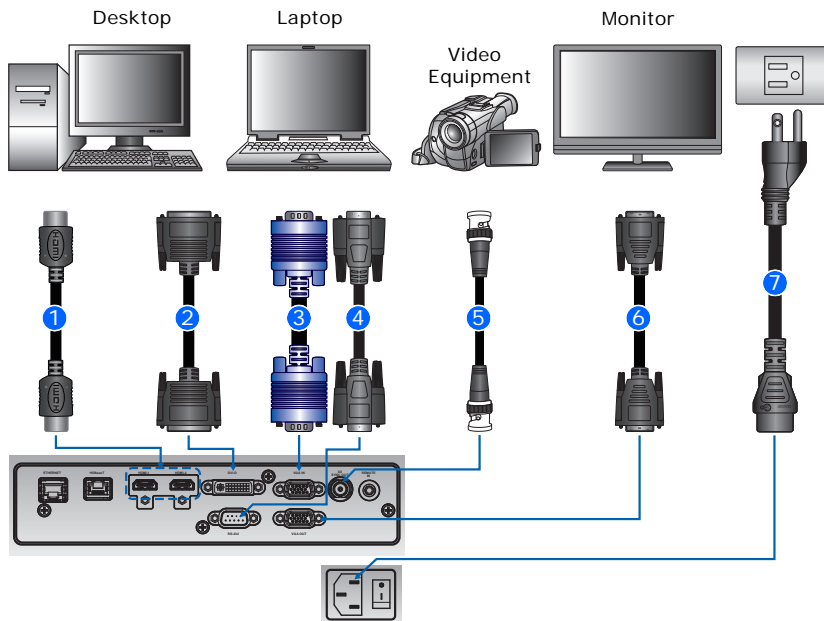

ID	Connector name	ID	Connector name	ID	Connector name
1	HDMI cable	4	RS-232 cable	7	Power cord
2	DVI-D cable	5	3D sync out cable		
3	VGA in cable	6	VGA out cable		



- Due to the difference in applications for each country, the accessories required in some regions may differ from those shown.
- This diagram is for illustrative purposes only, and does not indicate that these accessories are supplied with the projector.

## DWU635-GS/DHD635-GS Series

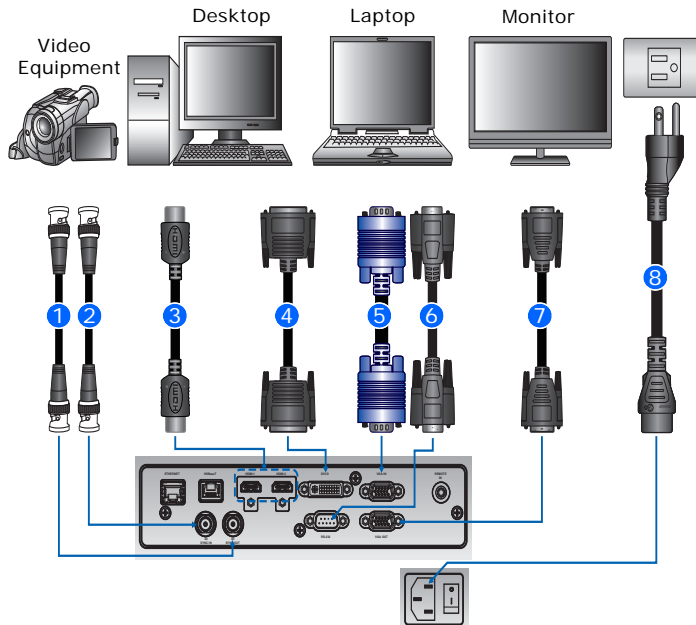

ID	Connector name	ID	Connector name	ID	Connector name
1	3D sync out cable	4	DVI-D cable	7	VGA out cable
2	3D sync in cable	5	VGA in cable	8	Power cord
3	HDMI cable	6	RS-232 cable		



- Due to the difference in applications for each country, the accessories required in some regions may differ from those shown.
- This diagram is for illustrative purposes only, and does not indicate that these accessories are supplied with the projector.

# Connecting to video equipment

Learn what cable/connectors may be used to connect to various devices.

## DWU630-GS/DHD630-GS Series

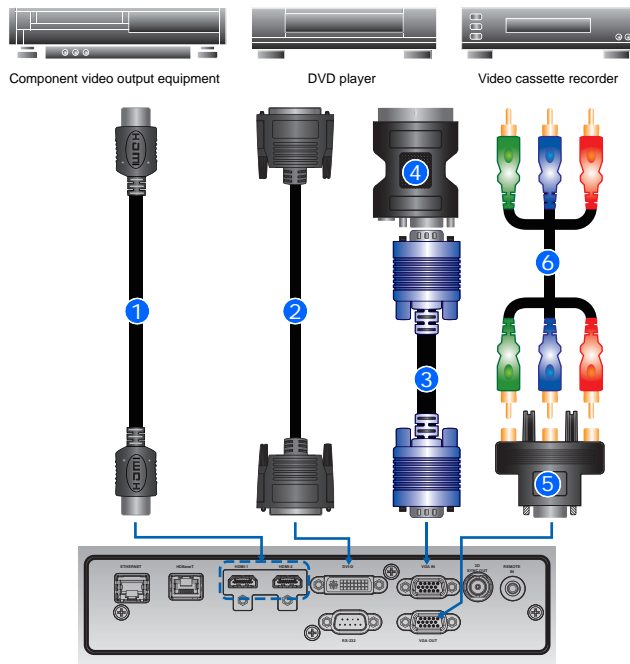

ID	Connector name	ID	Connector name	ID	Connector name
1	HDMI cable	3	VGA in cable	5	15-pin to 3 RCA Component/HDTV Adapter
2	DVI-D cable	4	VGA to Component	6	3 RCA Component cable



- Due to the difference in applications for each country, the accessories required in some regions may differ from those shown.
- This diagram is for illustrative purposes only, and does not indicate that these accessories are supplied with the projector.

## DWU635-GS/DHD635-GS Series

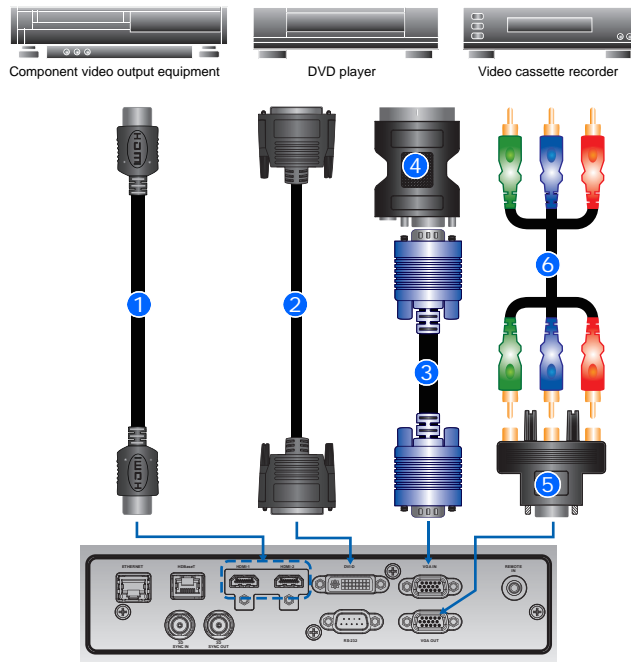

ID	Connector name	ID	Connector name	ID	Connector name
1	HDMI cable	3	VGA in cable	5	15-pin to 3 RCA Component/HDTV Adapter
2	DVI-D cable	4	VGA to Component	6	3 RCA Component cable



- Due to the difference in applications for each country, the accessories required in some regions may differ from those shown.
- This diagram is for illustrative purposes only, and does not indicate that these accessories are supplied with the projector.

# Turning the projector on

The projector cables must be securely connected before turning the power on.





**Warning!** Failure to comply with the following could result in death or serious injury.

- Do not look into the projector lens when the laser is on. The bright light may result in permanent eye damage

1. Connect the projector power cables to AC power.

The Power button on the keypad is illuminated when the power cables are connected.

2. Ensure the lens has been installed in the projector.
3. Ensure that no one or no objects are in the beam path before turning on the projector.
4. To turn on the projector, on the IR remote keypad press  or on the built-in keypad press .

The status LED is orange with a long blink. 

5. To select an input source and turn it on, on the IR remote keypad select **Input**. 

Available input sources are VGA, HDMI, DVI, and HDBaseT.

The projector detects the source you selected and displays the image.

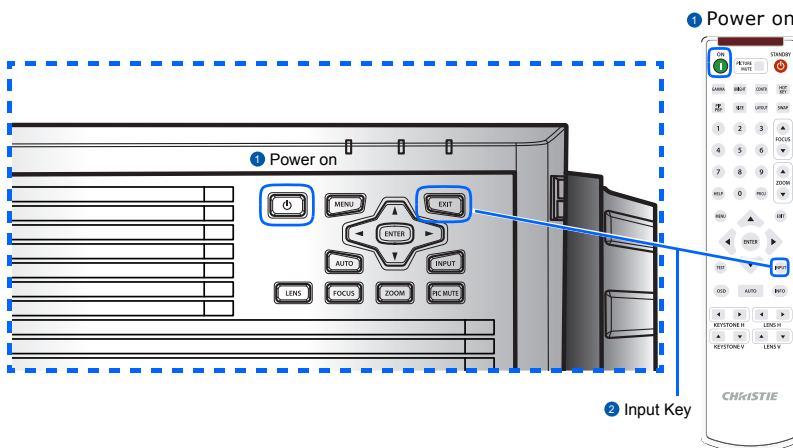

The first time the projector is used, select the preferred language from the Main Menu after the startup screen is displayed.

## Turning the projector off

Power off the projector in preparation for inspection or maintenance.

1. To turn the projector off, on the IR remote keypad or built-in keypad press **⏻**.

A warning message appears on the displayed image.

2. To confirm your selection, press **⏻** again.

If you do not press **⏻** again, the warning message disappears after three seconds and the projector remains on.

## Adjusting the projector position

When you select a position for the projector, consider the size and shape of your screen, the location of your power outlets, and the distance between the projector and the rest of your equipment. Follow these general guidelines:

- Position the projector on a flat surface at a right angle to the screen. The projector (with the standard lens) must be at least 3 feet (0.9 m) from the projection screen.
- Position the projector to the required distance from the screen. The distance from the lens of the projector to the screen, the zoom setting, and the video format determine the size of the projected image.
- Determine the lens throw ratio:
  - Lens 1.22~1.53 (WU/HD)
  - Lens 0.95~1.22 (WU/HD)
  - Lens 1.52~2.89 (WU/HD)
  - Lens 0.75~0.95 (WU/HD)
  - Lens 2.90~5.50 (WU/HD)
- 360 degree operation (along the widest axis)

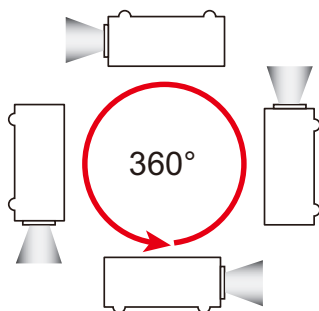

## Calculating the lens offset

Adjust the offset to align the image on the screen with half image size.

- The vertical image offset (shift) ranges for the projector are +/-100% (WUXGA) and +/-120% (HD).
- The horizontal image offset (shift) range for the projector are +/-30% (HD/WUXGA).
- The method for calculating lens offset complies with industry standards. For example for vertical lens offset:
  - At 0% offset (or on axis), the center of the image is on the lens center, so half of the image appears above and half appears below the lens center.
  - At +100% offset, the entire image appears above the lens center.
  - The percentage (%) offset is calculated as the ratio of the number of pixels shifted up or down to half image size.

### WUXGA projectors

The following show vertical and horizontal image offsets for the WUXGA projectors:

- Vertical image offset: 0%

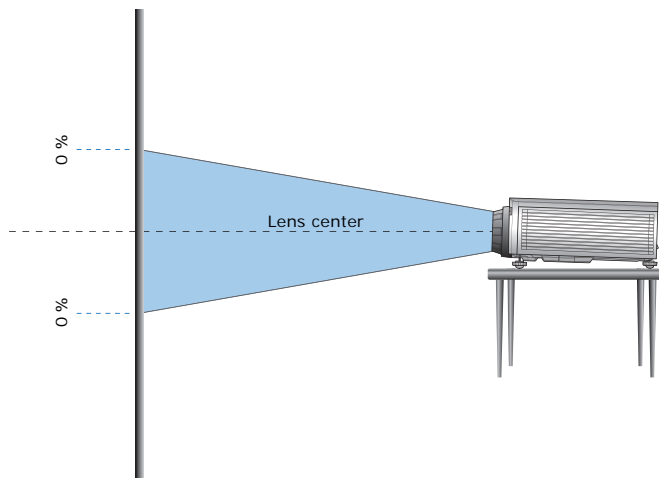



- Vertical image offset: +100%

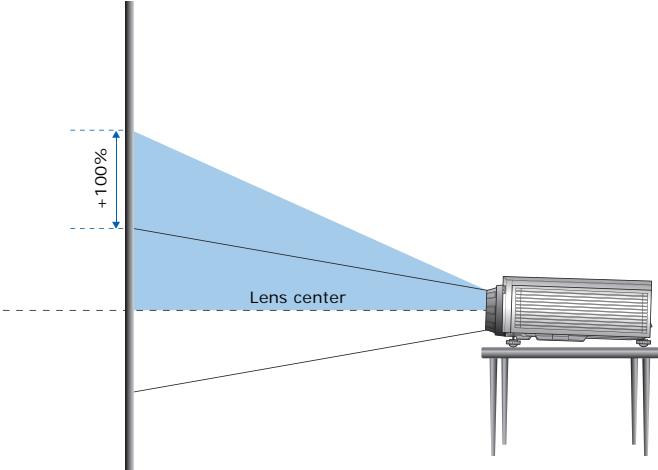

- Vertical image offset: -100%

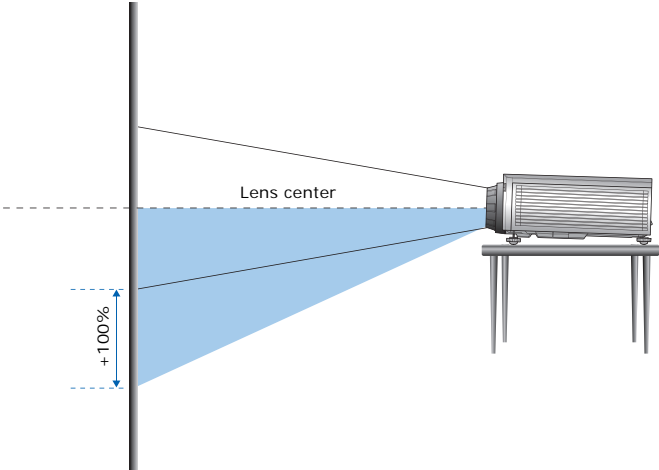

- Horizontal image offset: +/-30%

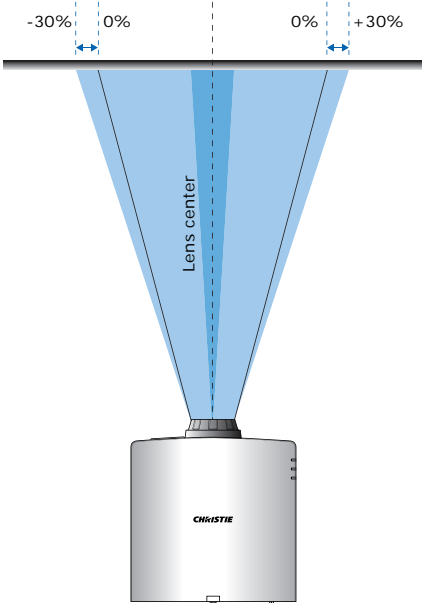

### HD Projectors

The following show vertical and horizontal image offset for HD projectors:

- Vertical image offset: 0%

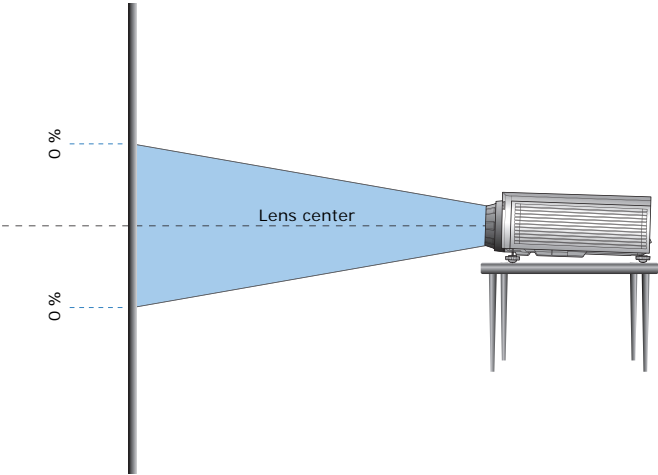

- Vertical image offset: +120%

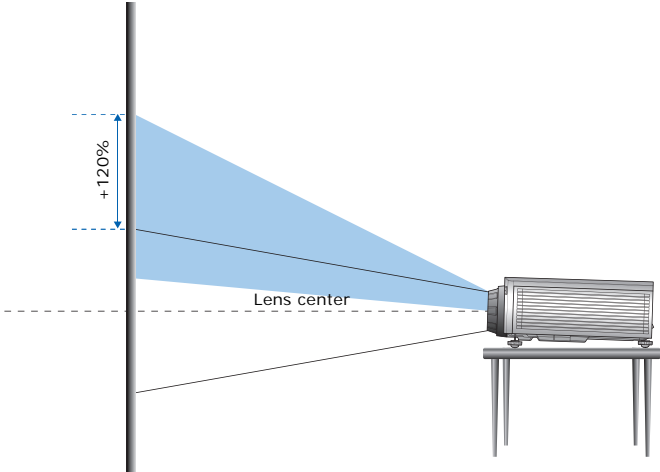

- Vertical image offset: -120%

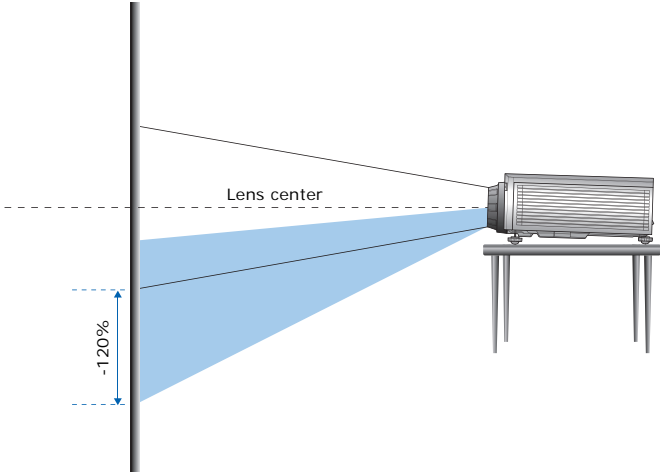

- Horizontal image offset: +/-30%

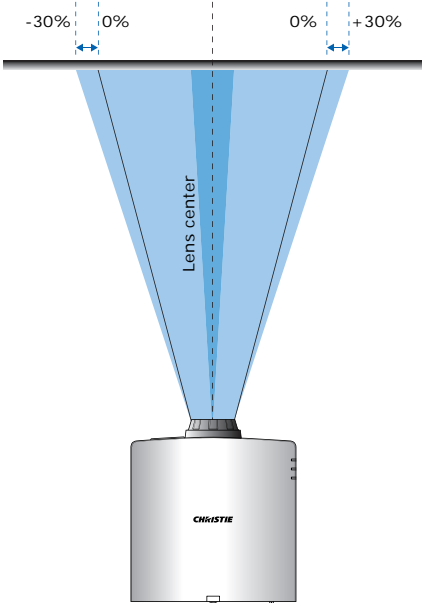

## Removing and installing the lens



**Warning!** Failure to comply with the following could result in death or serious injury.

- Turn off the projector and remove the power cord, before installing or replacing a lens.

When handling the projector after lens installation, make sure the front lens cap is placed on the lens to protect the lens surface from potential damage. When carrying or moving the projector, do not handle by the lens. This may damage the lens, the chassis, or other mechanical parts within the projector.

1. Center the lens. Ensure the lens is at or near its center position. Attempting to remove the lens with a large offset may cause damage to the lens assembly.

Center the lens while the projector is switched on by pressing the **Lens Horizontal** or **Lens Vertical** button and then pressing **Enter**.

2. Turn off the projector.
3. Allow the projector to cool down into standby mode before replacing the lens.
4. After the projector has cooled down and prior to replacing the lens, remove the power cord.
5. To remove the lens, remove the lens ring cover first. Then press the **Lens Release button** **A** with a tool and rotate the lens counterclockwise by a quarter **B** to release the lock.

Remove the lens through the front of the projector.

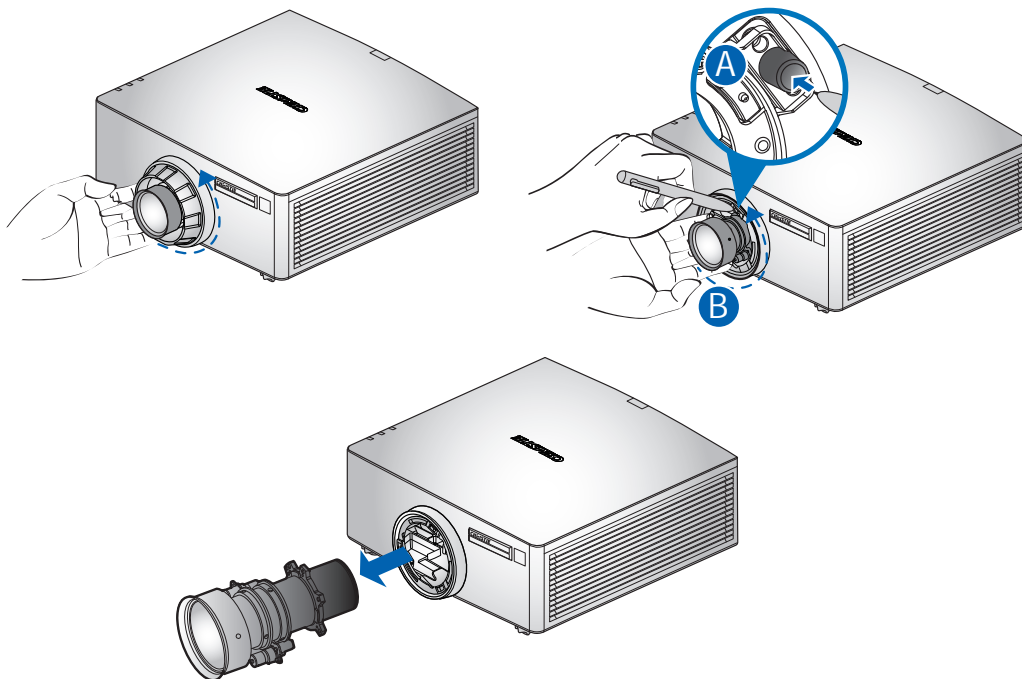

6. To install the new lens, fully insert the lens assembly straight into the lens mount without turning. Rotate the lens cap clockwise to lock the lens in place.



**Notice.** For ultra short throw lens installation information, refer to the [Ultra short throw lens installation instruction sheet \(P/N: 020-102569-XX\)](#).

## Installing the cable cover

1. Rotate the cable cover and insert the two guide pins into the guide holes.
2. Press and hold both lower corners of the cable cover while inserting the sheet clips into the projector casing.

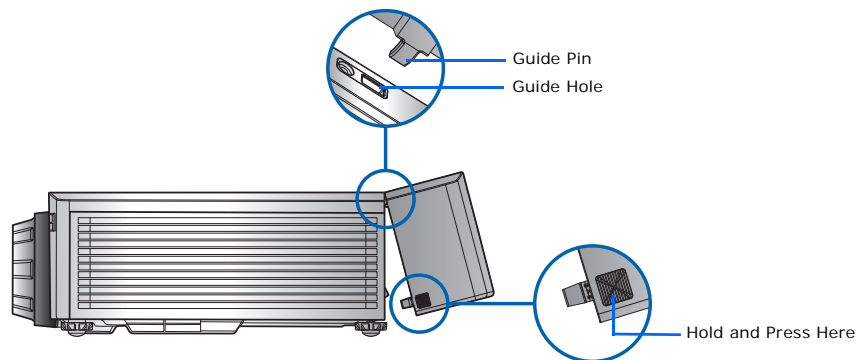

## Installing the ceiling mount

Mount the projector with a Christie-approved mount, using the four mounting points on the underside of the projector.

See [List of components](#) on page 77.

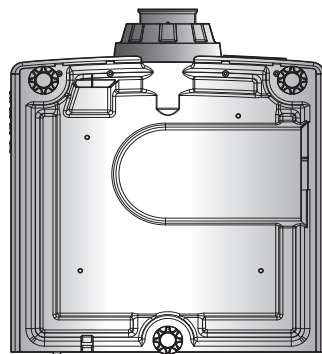

1. Refer to the installation instructions and safety guidelines provided in the kit.

See [List of components](#) on page 77.

## Rotating the Christie badge

The Christie magnetic badge on the front panel of the projector can be rotated for inverted installation.

1. Push on the edge of the badge to release it from its slot on the front panel.
2. Rotate the badge 180 degrees.
3. Push the badge back into its slot on the front panel. Make sure the badge is properly seated inside the slot.

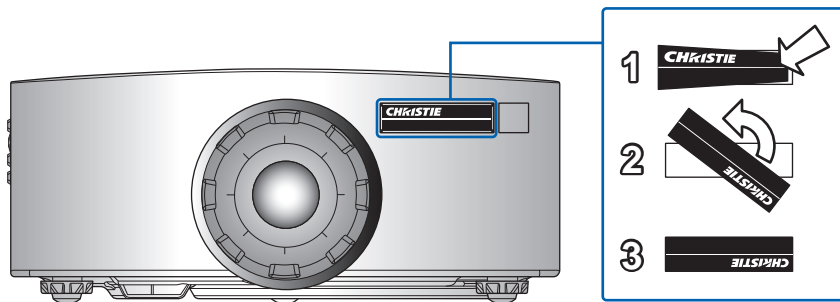

# Operation

The projector has multilingual on-screen display (OSD) menus so you can make image adjustments and change a variety of settings.

Most of the projector controls are accessed from within the projector menu system. Several groups of related functions are selectable from the Main menu as shown below.

1. To display the Main menu, on the IR remote keypad or on the built-in keypad on the right side of the projector, press **MENU**.
2. To navigate within the menu and adjust a setting up or down, use the arrow keys.
3. To select a highlighted menu item or use it to change or accept a value, press **ENTER**.  
You can then select the next item that you want to adjust in the menu and adjust it.
4. To exit menus if at top level, press **EXIT**.



## Picture menu

The Picture menu sets the picture settings, wall color, and other settings for images.



<b>Menu item</b>	<b>Description</b>	<b>Options</b>
Picture Settings	Optimizes the projector for displaying images under certain conditions. It affects the following: <ul style="list-style-type: none"> <li>• Gamma</li> <li>• Sharpness</li> <li>• White Peaking</li> <li>• Overscan</li> <li>• Brightness</li> <li>• Contrast</li> <li>• Color</li> <li>• Tint</li> <li>• Red Gain</li> <li>• Green Gain</li> <li>• Blue Gain</li> <li>• Red Offset</li> <li>• Green Offset</li> <li>• Blue Offset</li> </ul>	<ul style="list-style-type: none"> <li>• Bright</li> <li>• Presentation</li> <li>• Film</li> <li>• REC709</li> <li>• Blending</li> <li>• DICOM SIM.</li> <li>• User</li> </ul>
Wall Color	Sets the wall color so that the projector can enhance the color performance customized for the specific wall.	<ul style="list-style-type: none"> <li>• White</li> <li>• Gray 130</li> </ul>
Brightness	Adjusts the intensity of the image.	0-100
Contrast	Adjusts the degree of difference between the lightest and darkest parts of the image and changes the amount of black and white in the image.	0-100
Sharpness	Adjusts the edge clarity of the image.	0-10
Color	Adjusts a video image from black and white to fully saturated color. (Video sources only).	0-100
Tint	Adjusts the red-green color balance in the image of NTSC video images. (NTSC video sources only).	0-100
Gamma	Adjusts the mid-range levels.	<ul style="list-style-type: none"> <li>• Video</li> <li>• Film</li> <li>• Bright</li> <li>• CRT</li> <li>• DICOM</li> </ul>
White Peaking	Increases the brightness of whites near 100%.	0-100
Color Temp	Changes the intensity of the colors. Select a listed relative warmth value.	<ul style="list-style-type: none"> <li>• Warm</li> <li>• Bright</li> <li>• Cool</li> </ul>

Menu item	Description	Options
Color Wheel Speed	Selects the color wheel speed from 2x or 3x. The color wheel speed defines the delay between the color wheel and the DMD. The higher the speed, the less rainbow effect on the screen.	<ul style="list-style-type: none"> <li>• 2x</li> <li>• 3x</li> </ul>
HSG Adjustment	For more information on HSG adjustment, see <a href="#">HSG Adjustment</a> on page 37.	<ul style="list-style-type: none"> <li>• Red</li> <li>• Green</li> <li>• Blue</li> <li>• Cyan</li> <li>• Magenta</li> <li>• Yellow</li> <li>• White Gain</li> </ul>
Contrast Enhancement	Enables or disables the contrast enhancement function. Enable this function to raise the contrast ratio.	<ul style="list-style-type: none"> <li>• Off</li> <li>• Dynamic Black—Auto adjusts the contrast ratio for video contents.</li> <li>• Real Black—Reduces the black level for dark images to raise the contrast ratio.</li> </ul>
Color Space	Selects a color space specifically tuned for the input signal. Only useful for analog signals and certain digital sources.	<ul style="list-style-type: none"> <li>• Auto</li> <li>• RGB(0~255)</li> <li>• RGB(16~235)</li> <li>• YUV</li> </ul>

## HSG Adjustment

Hue, Saturation, and Gain (HSG) software controls the color regions R, G, B, C, M, Y, and W independently.

1. Select **Picture > HSG Adjustment**.

### Hue

Note the following about adjusting hue:

- Adjust the hue independently for each color (R,G,B,C,M, and Y).
- White does not have a hue input.
- A negative hue input provides a clockwise rotation of the color's hue.
- A positive hue input provides a counter-clockwise rotation of the color's hue.
- A zero input does not change the hue of the color.

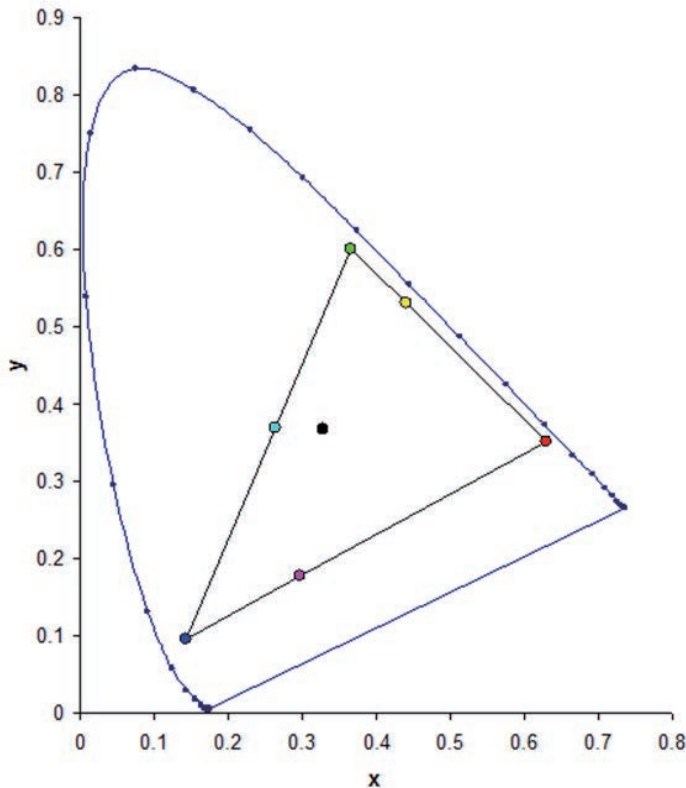

### Saturation

Note the following about adjusting saturation:

- The saturation can be adjusted independently for each color (R,G,B,C,M, and Y).
- A saturation level of 0 removes all color from that region.
- A saturation level of 254 sets the color region to have maximum color.

- A saturation level of 127 does not change the saturation.

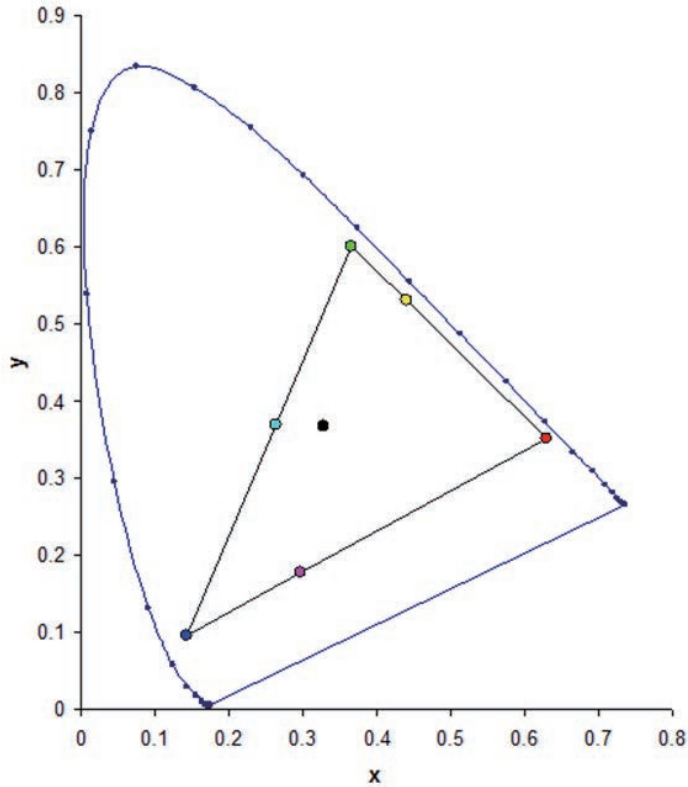

## Gain

Note the following about adjusting gain:

- The gain can be adjusted independently for each color (R,G,B,C,M,Y, and W).
- The range of input is 0 to 254.
- The gain changes the intensity level of the respective color.
- A gain level of 127 disables the HSG controls for that color.
- A gain level less than 127 darkens the respective color.
- A gain level of 254 sets the color region to have maximum gain; however, clipping occurs on the signal.
- A gain of 127 is the nominal setting.
- White provides three gain level controls, one each for the R,G,B component of white.

## Image blending

Adjust blend widths and settings to left, right, top and/or bottom sides to create a seamless multi-projector stitched image.

Image blending is only available for DWU635-GS and DHD635-GS.

### What is a blend?

A blend appears as a gradient strip along an edge of a projected image. It is darkest along the extreme edge of the image, and lightens nearer to the rest of the image (see below).



### How are blends used?

Complementary blends between neighboring images can compensate for the extra brightness or intensity where these edges overlap. By controlling blend width and other properties, you can achieve uniformity across the group of images. Visible overlaps disappear, as shown below.

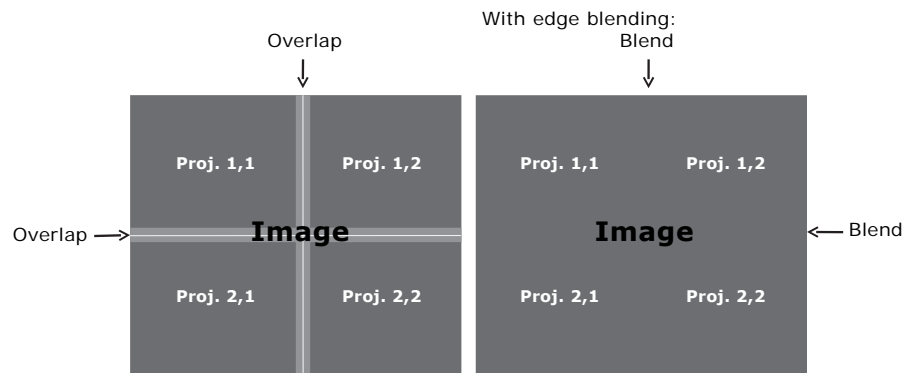

Blending regions can be defined on all sides—left, right, top, and bottom. The same gamma curve is used for all blending regions.

## Screen menu

The Screen menu determines the size and position of the image on the screen.



Menu item	Description	Options
Size Presets	Displays an image with the detected size, or resizes the image by maximizing either the height, width, both, or resizes to the maximum size possible while keeping the original aspect ratio.	<ul style="list-style-type: none"> <li>• Auto—Displays with the detected size.</li> <li>• 4:3—Retains 4:3 aspect ratio.</li> <li>• 16:9—Retains 16:9 aspect ratio.</li> <li>• 16:10—Retains 16:10 aspect ratio.</li> </ul>
Pixel Phase	Adjust the pixel phase when the image shows shimmer or noise after pixel tracking is optimized. Pixel phase can adjust the phase of the pixel-sampling clock relative to the incoming signal. (Analog RGB signals only.)	0-100

Menu item	Description	Options
Pixel Track	Ensures that the image quality is consistent across the screen, the aspect ratio is maintained, and the pixel phase can be optimized. Steady flickering or several soft vertical stripes or bands across the entire image indicates poor pixel tracking. (Analog RGB signals only).	0-100
Horz Position	Moves the image right or left within the area of available pixels.	0-100
Vert Position	Moves the image up or down within the area of available pixels.	0-100
Digital Horz Zoom	Changes the size of projector's display area horizontally. If the display area has been resized by this setting, it can be moved by changing the Digital Horz Shift.	0-10
Digital Vert Zoom	Changes the size of projector's display area vertically. If the display area has been resized by this setting, it can be moved by changing the Digital Vert Shift settings.	0-10
Digital Horz Shift	Moves the display area horizontally if its size has been changed by the Digital Horz Zoom setting.	0-100
Digital Vert Shift	Moves the display area vertically if its size has been changed by the Digital Vert Zoom setting.	0-100
Ceiling Mount	Turns the image upside down for ceiling-mounted projection.	<ul style="list-style-type: none"> <li>• Off</li> <li>• On</li> <li>• Auto—Projector would detect automatically.</li> </ul>
Rear Projection	Reverses the image so that you can project from behind a translucent screen.	<ul style="list-style-type: none"> <li>• Off</li> <li>• On</li> </ul>
Geometry Correction	Provides several ways for warping control. For more information on geometry correction, see <a href="#">Geometry Correction</a> on page 43.	<ul style="list-style-type: none"> <li>• H. Keystone—Adjusts the keystone horizontally and make a more square image. 0-40</li> <li>• V. Keystone—Adjusts the keystone vertically and make a more square image. 0-40</li> <li>• 4 Corners—Allows the image to be squeezed to fit an area defined by moving each of the four corners' x and y position.</li> <li>• Grid Color—Choose the color of 4 corner, green or purple.</li> <li>• Reset—Restore the settings to its default value.</li> <li>• PC Mode off—User can do simple horizontal and vertical keystone, and 4-corner control by using the on-screen display.</li> <li>• PC Mode on—User can do arbitrary warping or blending control by using PC APP provided separately.</li> </ul>



Menu item	Description	Options
PIP-PBP Settings	<p>Displays an image with two sources in PIP mode or PBP mode.</p> <p>Refer to <a href="#">PIP/PBP Settings menu</a> on page 44 and <a href="#">PIP/PBP layout and size</a> on page 46.</p>	<ul style="list-style-type: none"> <li>• Function—Toggles between displaying two sources at once (main and PIP/PBP images) or one source only.</li> <li>• Main Source—Selects an active input to be used as the main image.</li> <li>• Sub Source—Selects an active input to be used as the PIP/PBP.</li> <li>• Location—Sets the location of the PIP image on the screen.</li> <li>• Size—Selects the PIP size to small, medium, or large.</li> <li>• Swap—Changes the main image to PIP/PBP, and the PIP/PBP to main image. Swapping is available only when PIP/PBP is enabled.</li> </ul>
Input Key	<p>Lists or changes the sources.</p>	<ul style="list-style-type: none"> <li>• Change Sources</li> <li>• List all Sources</li> <li>• Auto Source</li> </ul>
Auto Image	<p>Forces the projector to reacquire and lock to the input signal. This is useful when signal quality is marginal.</p>	<ul style="list-style-type: none"> <li>• Normal—Supports all of the 4:3 input sources.</li> <li>• Wide—Supports all of the 16:9 input source and most of the 4:3 input source.</li> </ul> <p>For the 4:3 input sources not recognized by Wide mode (for example, 1400 x 1050), perform Auto Image using Normal mode.</p>
Source Info	<p>Displays the current source settings. (Read-only).</p>	

## Geometry Correction

Geometry correction provides two ways for warping control:

- PC Mode off—User can do simple horizontal and vertical keystone, and 4-corner control by using the on-screen display.
- PC Mode on—User can do arbitrary warping or blending control by using the PC APP provided separately.



- PC mode is only available for DWU635-GS and DHD635-GS.

The following table provides information about the geometry correction feature compatibility:

Warp Function	4 Corners	Keystone
4 Corners	--	✓
Keystone	✓	--



- The Geometry Correction function for DWU630-GS and DHD630-GS models is not supported while using PC mode.

### H. Keystone

Adjust the keystone horizontally and make a more square image. Horizontal keystone is used to correct a keystone image shape in which the left and right borders of the image are unequal in length, and the top and bottom are slanted to one of the sides. This is intended for use with horizontally on-axis applications.

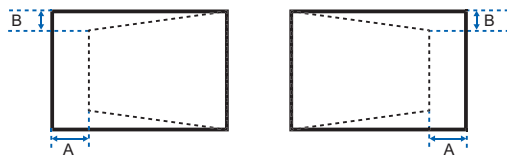

Ind.	1080P	WUXGA
A	10.00%	7.20%
B	6.50%	5.30%

### V. Keystone

Adjust the keystone vertically and make a more square image. Vertical keystone is used to correct a keystone image shape in which the left and right borders of the image are unequal in length, and the top and bottom are slanted to one of the sides. This is intended when for use with vertically on-axis applications.

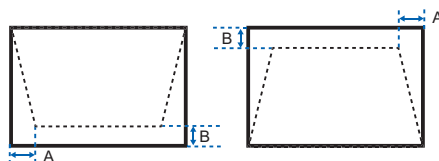

Ind.	1080P	WUXGA
A	4.40%	3.41%
B	8.93%	5.46%

### 4 Corners

Allow the image to be squeezed to fit an area defined by moving each of the four corners' x and y position.

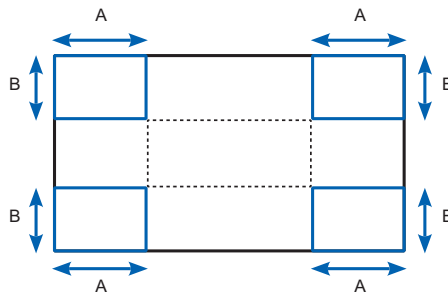

Ind.	1080P	WUXGA
A	7.30%	7.30%
B	7.40%	6.70%

### PIP/PBP Settings menu

The PIP/PBP Settings menu determines how the main and PIP/PBP inputs are handled.

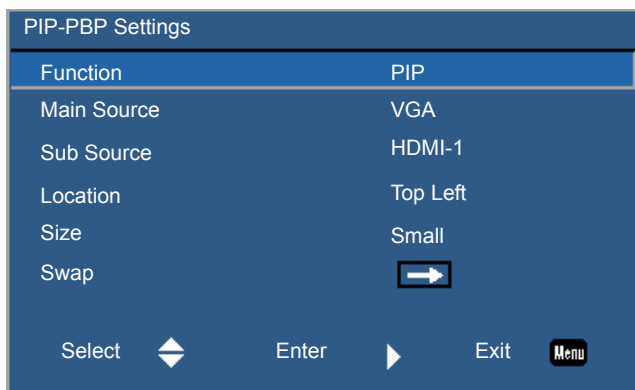















Menu item	Description	Options
Function	Toggles between displaying two sources at once (Main and PIP/PBP images) or one source only.	<ul style="list-style-type: none"> <li>Off—Displays image from the main source only.</li> <li>PBP—Displays images from two sources by separating the screen into two parts. One source is displayed on the main screen and another source is displayed in an inset window.</li> <li>PIP—Displays images from two sources by separating the screen into half. One source is displayed on the left side of the screen and the other source on the right side of the screen.</li> </ul> <p>Refer to <i>PIP/PBP layout and size</i> on page 46.</p>

Menu item	Description	Options
Main Source	Selects an active input to be used as the main image.	<ul style="list-style-type: none"> <li>• VGA</li> <li>• HDMI-1</li> <li>• HDMI-2</li> <li>• DVI</li> <li>• HDBaseT</li> </ul>
Sub Source	Selects an active input to be used as the sub image.	<ul style="list-style-type: none"> <li>• VGA</li> <li>• HDMI-1</li> <li>• HDMI-2</li> <li>• DVI</li> <li>• HDBaseT</li> </ul>
Location	Sets the location of the PIP/PBP image on the screen. Refer to <i>PIP/PBP layout and size</i> on page 46.	<ul style="list-style-type: none"> <li>• Top Left</li> <li>• Top Right</li> <li>• Bottom Left</li> <li>• Bottom Right</li> </ul>
Size	Selects the PIP/PBP size to small, medium, or large.	—
Swap	Changes the main image to PIP/PBP, and the PIP/PBP to main image. Swapping is available only when PIP/PBP is enabled.	—

## PIP/PBP layout and size

A P indicates the primary source region (lighter color) and an asterisk (\*) indicates both regions are the same size.

PIP Layout	PIP Size		
	Small	Medium	Large
PIP-Bottom Right			
PIP-Bottom Left			
PIP-Top Left			
PIP-Top Right			

PBP Layout	PBP Size		
	Small	Medium	Large
PBP, Main Left	--	--	
PBP, Main Right	--	--	

# Settings Menu

The Settings menu sets the language, menu location, LAN (standby), and other preferences for the projector.



Menu item	Description	Options
Language	Selects an available language for the on-screen display.	<ul style="list-style-type: none"> <li>• English</li> <li>• Chinese (Simplified)</li> <li>• French</li> <li>• German</li> <li>• Italian</li> <li>• Japanese</li> <li>• Korean</li> <li>• Russian</li> <li>• Spanish</li> </ul>

<b>Menu item</b>	<b>Description</b>	<b>Options</b>
Menu Location	Sets up the on-screen display menu location.	<ul style="list-style-type: none"> <li>• Left Top</li> <li>• Right Top</li> <li>• Center</li> <li>• Left Bottom</li> <li>• Right Bottom</li> </ul>
LAN (Standby)	Determines the power modes for projector.	<ul style="list-style-type: none"> <li>• 0.5W mode—Low power mode.</li> <li>• Communication mode—Normal power mode.</li> </ul>
Test Pattern	Chooses the required internal test pattern to display.	<ul style="list-style-type: none"> <li>• None</li> <li>• Grid</li> <li>• White</li> <li>• Black</li> <li>• Checkerboard</li> <li>• Color Bars</li> </ul>
Direct Power On	Automatically turns the projector on when electrical power is connected.	<ul style="list-style-type: none"> <li>• On</li> <li>• Off</li> </ul>
Hot-Key Settings	<p>Assigns a different function to the hot key on the IR remote keypad by highlighting the function in the list and pressing <b>Enter</b>.</p> <p>Chooses a function that does not already have a dedicated button, and assign the hot key to that function, allowing you to quickly and easily use the chosen function.</p>	<ul style="list-style-type: none"> <li>• Blank Screen</li> <li>• Aspect Ratio</li> <li>• Freeze Screen</li> <li>• Projector Info</li> </ul>
Reset to Default	Restores all settings to their default value. It does not reset network but it resets RS232.	<ul style="list-style-type: none"> <li>• Yes</li> <li>• No</li> </ul>
Service	Displays projector information, sets test patterns, error logs, and high temperature warnings.	<ul style="list-style-type: none"> <li>• Projector Info—Displays the current projector settings. (Read-only)</li> <li>• Factory Reset—Restores all settings to their default value. It does not reset network but it resets RS232.</li> <li>• Test Pattern—Sets the required internal test pattern to display. To turn off a test pattern, select Off.</li> <li>• Wheel Index (2x)—Sets the wheel index to Speed 2X. Only use this setting when a new main board is installed, and the picture quality needs to be optimized.</li> <li>• Wheel Index (3x)—Sets the wheel index to Speed 3X. Only use this setting when a new main board is installed, and the picture quality needs to be optimized.</li> <li>• Error Log—Shows the projector error log for debug.</li> <li>• Laser Diode Info—Displays the information of each laser diode bank including its voltage, current, and temperature.</li> </ul>

## Language menu

Select an available language for the on-screen display.



## Test Pattern menu

Choose the required internal test pattern to display, or select **None** to turn off a test pattern.





## Light Source menu

The Light Source menu sets the light source mode and power preferences.

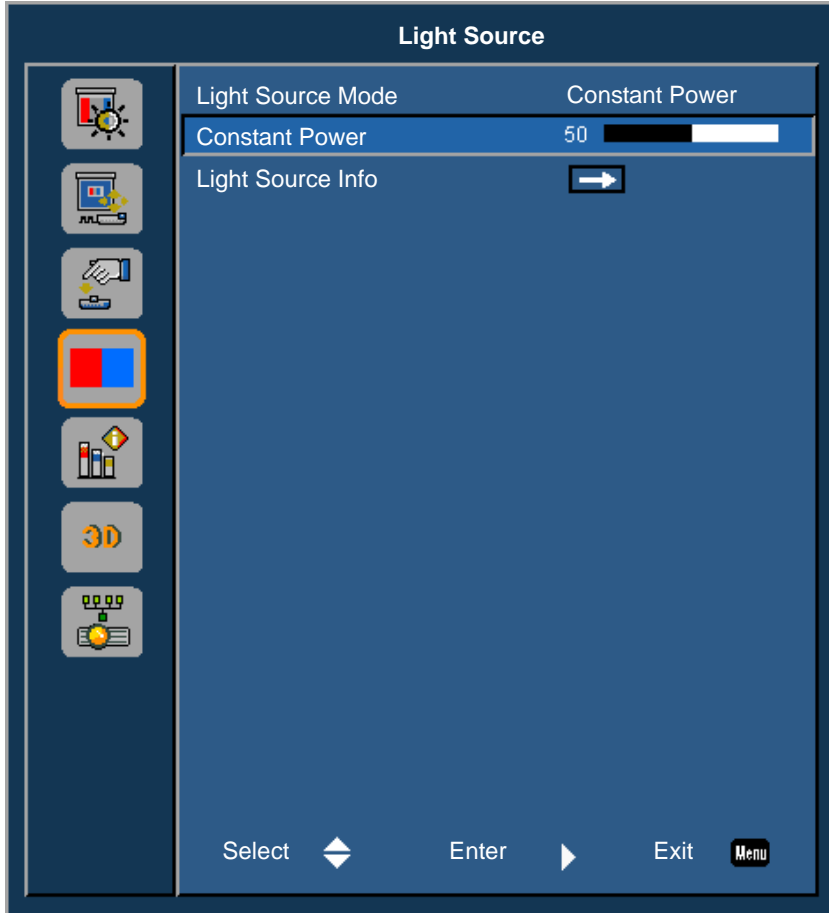

Menu item	Description	Options
Light Source Mode	Sets the light source mode.	<ul style="list-style-type: none"> <li>Constant Power</li> <li>Constant Intensity</li> <li>ECO 1—The factory default brightness is 80%.</li> <li>ECO 2—The factory default brightness is 50%.</li> </ul>
Constant Power	Sets the value of the laser diode power.	0-99
Light Source Info	Displays the total hours of the projector, the total hours of the laser diode that have been used, and information on the light sensor calibration.	—

# Options Menu

The Options menu allows to select the splash screen, configure auto shutdown parameters, set sleep timer, and configure other options for the projector.



Menu item	Description	Options
Splash Screen	Selects the splash screen.	<ul style="list-style-type: none"> <li>• Factory Logo</li> <li>• Blue</li> <li>• Black</li> <li>• White</li> </ul>
Auto Shutdown	Automatically turns the projector off after no signals are detected for a preset number of minutes. If an active signal is received before the projector powers down, the image is displayed.	0-120 mins

<b>Menu item</b>	<b>Description</b>	<b>Options</b>
Sleep Timer	Allows the projector to automatically power off after it has been on for a specified amount of time.	0-990 mins
Lens Settings	Adjusts the lens parameters.	<ul style="list-style-type: none"> <li>• Focus—Adjusts the focus point of the image.</li> <li>• Zoom—Adjust the zoom of the image in or out.</li> <li>• Lens Shift—Shifts the lens up and down, or left and right.</li> <li>• Lock Lens Motors—Selects this function to prevent all lens motors from moving. It will disable the Zoom, Focus, Horizontal and Vertical Position settings, effectively locking out any changes and overriding all other lens features. This is particularly useful to prevent accidental lens position changes in multi-projector installations.</li> <li>• Lens Calibration—Calibrates to move the lens back to center.</li> </ul>
High Altitude	Enables or disables high altitude mode.	<ul style="list-style-type: none"> <li>• On—Enables high altitude mode for altitudes <math>\geq</math> 2000 m. The fan operates at high speed to ensure sufficient air flow for high altitudes.</li> <li>• Off—Disables high altitude mode. For altitudes below 2000m.</li> </ul>
PIN Protect	Protects your projector with a password. Once enabled, you must enter the password before you can project an image.	—
Remote Settings	Turns on/off remote settings.	<ul style="list-style-type: none"> <li>• Top</li> <li>• Front</li> <li>• HDBaseT</li> <li>• Projector Address. 0-9.</li> </ul>
Information Hide	Hides or displays projector settings.	<ul style="list-style-type: none"> <li>• On</li> <li>• Off</li> </ul>
Backlight Preferences	Controls the backlight behavior and status LED.	<ul style="list-style-type: none"> <li>• Keypad Backlight</li> <li>• Status LED</li> </ul>
Information	Displays the projector settings. (Read-only)	—

## Information menu

The read-only Information menu lists a variety of details about the standard and optional components currently detected in the projector.

### For DHD Models

Information	
Model Name	DHD635-GS
Serial Number	BWH1709E01
Native Resolution	1920 x 1080
MCU FW	A00.50
DDP FW	V02.19
M9813 FW	M00.09
Motor FW	K00.02
PW808 FW	B03.78
Main Input	VGA
Main Signal Format	Digital Video
Main Pixel Clock	74.2MHz
Main Sync Type	Sync On Green
Main Horz Refresh	45.1kHz
Main Vert Refresh	60.0Hz
PIP/PBP Input	HDMI-1
PIP/PBP Signal Format	-
PIP/PBP Pixel Clock	-
PIP/PBP Sync Type	-
PIP/PBP Horz Refresh	-
PIP/PBP Vert Refresh	-
Light Source Power	99
Total Projector Hours	70
Light Source Hours	70
Standby Mode	Communication mode
Lens Lock Settings	Allow
IP Address	192.168.0.100
DHCP	Off
System Temperature	38°C

Exit 

**For DWU Models**

Information	
Model Name	DWU635-GS
Serial Number	BWU1709E01
Native Resolution	1920 x 1080
MCU FW	A00.50
DDP FW	V02.19
M9813 FW	M00.09
Motor FW	K00.02
PW808 FW	B03.78
Main Input	VGA
Main Signal Format	Digital Video
Main Pixel Clock	74.2MHz
Main Sync Type	Sync On Green
Main Horz Refresh	45.1kHz
Main Vert Refresh	60.0Hz
PIP/PBP Input	HDMI-1
PIP/PBP Signal Format	-
PIP/PBP Pixel Clock	-
PIP/PBP Sync Type	-
PIP/PBP Horz Refresh	-
PIP/PBP Vert Refresh	-
Light Source Power	99
Total Projector Hours	70
Light Source Hours	70
Standby Mode	Communication mode
Lens Lock Settings	Allow
IP Address	192.168.0.100
DHCP	Off
System Temperature	38°C

Exit 

## 3D menu

The 3D menu sets the usage of 3D function and its settings.



Menu item	Description	Options
3D	Enables 3D content detection.	<ul style="list-style-type: none"> <li>• On</li> <li>• Auto</li> </ul>
3D Invert	Inverts the 3D sync signal when using a single projector.	<ul style="list-style-type: none"> <li>• On</li> <li>• Off</li> </ul>
3D Format	Sets the 3D format. Supports mandatory 3D formats and frame sequential 3D@120Hz.	<ul style="list-style-type: none"> <li>• Frame Packing</li> <li>• Side-by-Side(Half)</li> <li>• Top and Bottom</li> <li>• Frame Sequential (635-GS only)</li> </ul>
1080p@24	Sets the 3D resolution 1080p@24 frequency.	<ul style="list-style-type: none"> <li>• 96Hz</li> <li>• 144Hz</li> </ul>

Menu item	Description	Options
3D Sync Out	Transmits a 3D sync signal by the 3D sync output corrector to the emitter or to the next projector for 3D blending purposes.	—
Frame Delay	Corrects asynchronous displaying of images under 3D blending.	—
L/R Reference	Source of the left or right reference.	<ul style="list-style-type: none"> <li>• 1st Frame—This is used for single 3D projector.</li> <li>• Field GPIO—Select Field GPIO to make the first 3D output signal the same for multi-projectors application.</li> </ul>

## Communications menu

The Communications menu sets the LAN parameters, network status, and other settings for the projector.

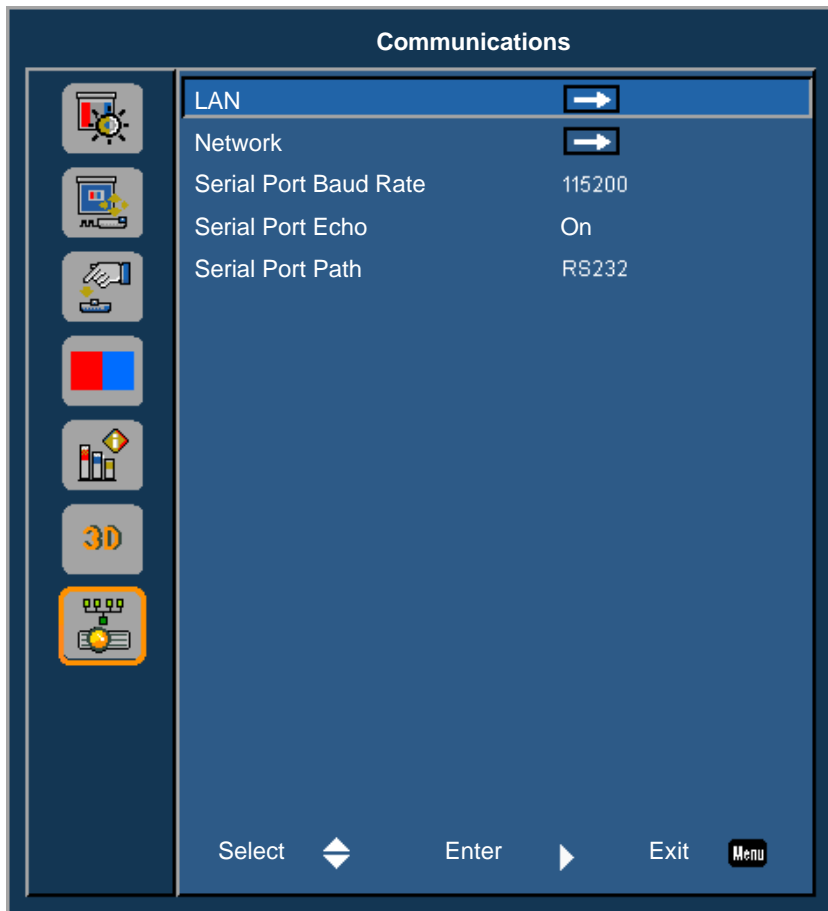

Menu item	Description	Options
LAN	Determines the communication settings.	<ul style="list-style-type: none"> <li>• DHCP—Turns the DHCP on or off.</li> <li>• IP Address—Assigns the network IP address.</li> <li>• Subnet Mask—Assigns the network subnet mask.</li> <li>• Default Gateway—Assigns the network default gateway.</li> <li>• MAC Address—Displays the network MAC address value.</li> <li>• Apply—Apply the LAN configuration when the setting is changed or added.</li> </ul>
Network		<ul style="list-style-type: none"> <li>• Projector Name—Displays the projector name.</li> <li>• Show Network Messages—Turns network messages on or off.</li> <li>• Restart Network—Restarts the network.</li> <li>• Network Factory Reset—Performs factory reset on the network settings. The Projector Name, IP Address (LAN), Start IP and End IP, and SNMP settings can be reset.</li> </ul>
Serial Port Baud Rate	Selects the serial port and baud rate.	<ul style="list-style-type: none"> <li>• 1200</li> <li>• 2400</li> <li>• 4800</li> <li>• 9600</li> <li>• 14400</li> <li>• 19200</li> <li>• 38400</li> <li>• 57600</li> <li>• 115200</li> </ul>
Serial Port Echo	Controls whether the serial port echoes characters.	<ul style="list-style-type: none"> <li>• Off</li> <li>• On</li> </ul>
Serial Port Path	Sets the serial port path to RS232 or HDBaseT.	<ul style="list-style-type: none"> <li>• RS232</li> <li>• HDBaseT</li> </ul>



## LAN settings

The LAN menu sets the DHCP, IP address, and other network settings for the projector.

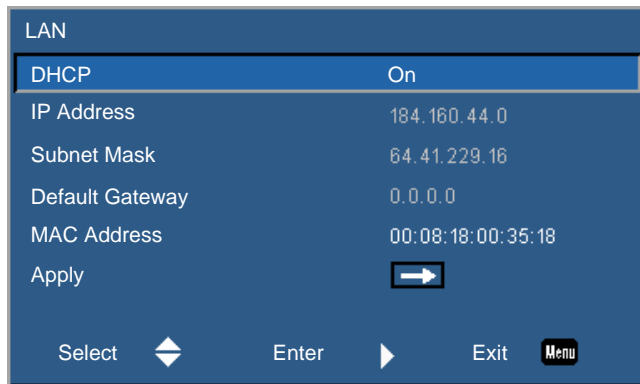

## Web user interface

The web user interface provides an alternate way to access the menu functionality on the projector.

### Logging on to the web user interface

Log onto the web user interface by following the steps below.

1. Open a web browser and type the IP address (in the address bar) assigned to your projector.



The screenshot shows the Christie Projector Web Management login interface. At the top, the Christie logo is displayed. Below it, the text reads "Welcome to Projector Web Management" and "Compatible with Internet Explorer 8 or higher". The form includes the following fields and options:

- Projector model name: DHD630-GS
- Access type: user (dropdown menu)
- Password: [text input field]
- Language: English (dropdown menu)
- Login button
- Christie Presenter Download button

At the bottom of the page, a blue footer contains the text: "Copyright© 2014 Christie Digital Systems. All rights reserved."

2. From the Access type list, select the log in level.
3. In the Password field, type the password.
4. From the Language list, select the appropriate language.
5. To access the Main window, click **Login**.

## Main tab-General

Displays information about the projector, its power status, and what is selected for the main and PIP/PBP input sources.

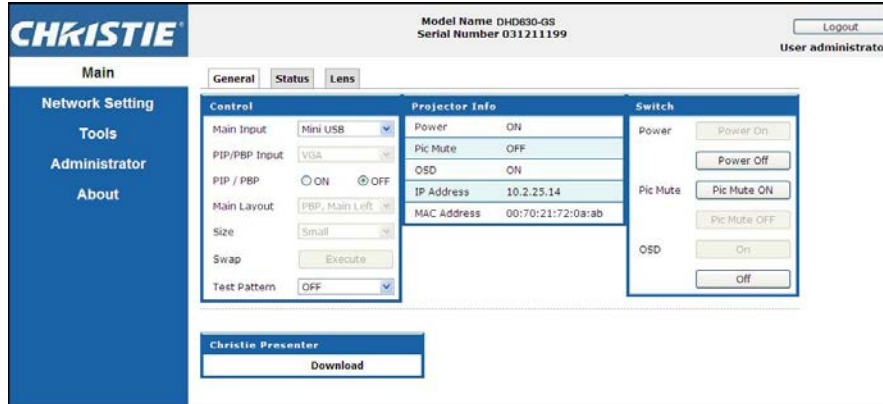

Panel	Description
Control	Selects main source/PIP source, enables or disables PIP/PBP, changes the layout or PIP size, swap, and change the test pattern.
Projector Information	Check the projector information for power status, Pic mute status, on-screen display status, IP address, and MAC address.
Switch	Switches the on or off status of Power, Pic Mute, and on-screen display.

## Main tab-Status

Displays the current status of light source, cooling (fans), version numbers, and signal (source) information.



## Main tab-Lens

Controls the focus, lens shift, and zoom adjustments for the lens.



## Network

If you change a setting, the network subsystem of the projector may restart, and you may be logged off.

The screenshot displays the Christie network configuration web interface for a DHD630-GS projector. The interface includes a navigation menu on the left with options: Main, Network Setting, Tools, Administrator, and About. The main content area shows the following sections:

- Projector Information:** Model Name DHD630-GS, Serial Number 031211199. Projector Name: Christie031211199.
- Network Control:** Show Network Messages (ON/OFF), Restart Network... (Execute), Network Factory Reset... (Execute).
- LAN Configuration:** DHCP (selected) or Manual. IP Address: 10.2.25.14, Subnet Mask: 255.255.252.0, Default Gateway: 10.2.27.254, MAC Address: 00:70:21:72:0a:ab.
- WLAN Configuration:** Enable (selected) or Disable. Start IP: 192.168.1.100, End IP: 192.168.1.120, Subnet Mask: 255.255.255.0, Default Gateway: 192.168.1.100.
- SNMP Configuration:** Read Community: private, Location: [empty], Trap IP Address: 0.0.0.0, Trap Email 1/2: [empty], Email From Address: [empty], SMTP Server IP Address: 0.0.0.0.
- Trap Configuration:** Light Source Life, Light Source Fault, Fan Stall, Thermal Sensors, Power, Signal Lost/Detected. All are set to 'SNMP Trap +Email'.
- Crestron Control System:** IP Address: 192.168.0.2, IP ID: 5, Port: 41794.

**Note:** If you change the setting, the projector's network subsystem will restart, and you will be logged off.

Panel	Description	Fields
Restart Network	Executes a network restart. This does not change any of the network settings.	

Panel	Description	Fields
Network Factory Reset	<p>Execute a network factory reset. Network settings may be reset to the following default values.</p> <p>Projector Name = Christie@ + Serial Number</p> <p>Show Network Messages = ON</p>	<p>LAN settings:</p> <ul style="list-style-type: none"> <li>• Manual</li> <li>• IP Address = 192.168.0.100</li> <li>• Subnet Mask = 255.255.255.0</li> <li>• Default Gateway = 192.168.0.100</li> </ul> <p>WLAN settings:</p> <ul style="list-style-type: none"> <li>• Enabled</li> <li>• Start IP = 192.168.1.100</li> <li>• End IP = 192.168.1.120</li> <li>• Subnet Mask = 255.255.255.0</li> <li>• Default Gateway = 192.168.1.100</li> </ul> <p>SNMP settings:</p> <ul style="list-style-type: none"> <li>• SNMP Read Community = private</li> <li>• Trap IP Address = 0.0.0.0</li> <li>• SMTP IP Address = 0.0.0.0</li> <li>• All other settings are cleared or blanked</li> </ul> <p>Trap Configuration:</p> <ul style="list-style-type: none"> <li>• All items = SNMP Trap + Email</li> </ul>
LAN Setting Panel	<p>Sets if the projector must obtain an automatically assigned IP address through DHCP or if the user sets the address manually.</p>	<p>For the TCP/IP setting, enter the IP address, netmask, and default gateway address.</p>
WLAN Setting Panel	<p>Enables or disables the wireless LAN of the projector.</p>	<p>Enter the IP address range, netmask, and default gateway for the wireless LAN.</p>
SNMP Panel	<p>Provides network administrators with a common way to manage their network devices from a single remote location.</p> <p>Administrators can use the Simple Network Management Protocol (SNMP) interface to query a number of devices to see their current status or configuration.</p> <p>Operators can change configuration values and configure trap notifications to be sent when certain events occur (for example, loss of signal, power state change, and so on).</p> <p>Emails are sent to the mail server configured in the projector settings. Up to two user email accounts can be selected. Important information regarding the event is located in the body content of the email.</p> <p>SNMP Traps are notifications sent from the projector and are only received by a trap receiver (MIB Browser) in the computer.</p>	<ul style="list-style-type: none"> <li>• SNMP Read Community (default setting: private)—Plain text password that must also be entered in the MIB browser. This password allows various settings in the projector to be queried.</li> <li>• SNMP Location (default setting: blank)—Use as a description to where a projector is located in a building. SNMP emails sent specify this location.</li> <li>• Trap IP Address (default setting: 0.0.0.0)—Fill in this field with the IP address of the computer, on which you want to view received traps from the projector.</li> <li>• Trap Email 1/2 (default setting: Blank)—Set the Trap Email 1 and 2 to an email address configured under the mail server entered in the SMTP Server IP Address field.</li> <li>• Email from Address (default setting: blank)—Set the name of the source of the SNMP emails.</li> <li>• SMTP Server IP Address (default setting: 0.0.0.0)—Enter the IP address of the mail server.</li> </ul>

Panel	Description	Fields
Trap Configuration Panel	Set the SNMP actions for the system events.	<ul style="list-style-type: none"> <li>• SNMP Trap</li> <li>• + Email</li> <li>• Email</li> <li>• SNMP Trap</li> <li>• Disabled</li> </ul>
Crestron Control System Panel	Provides the information to connect to a Crestron device.	Enter the IP address, IP ID, and port of Crestron device for the connection.

## Tools

Use the Tools pages to control size & position, image settings, configuration, light source, input switching, PIP, and test patterns.

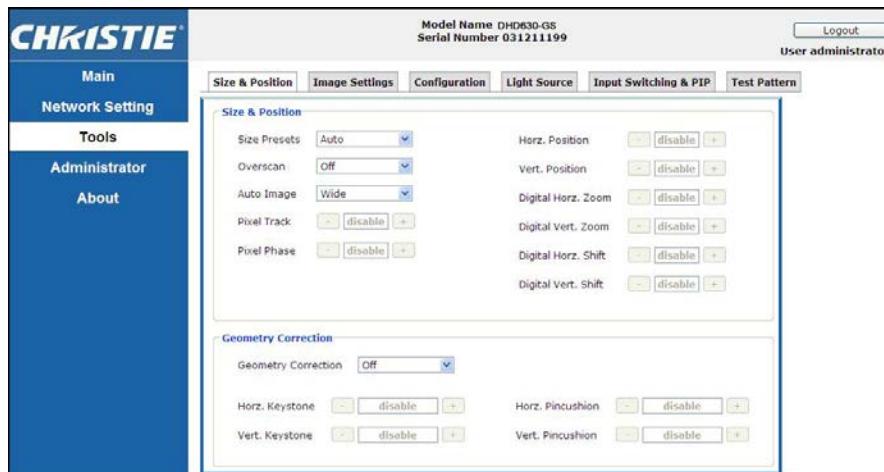

## Administrator Page

Add or delete a user or change password.



## About Page

The About page provides version and license information about GS Series.



Tab	Description
Version	Views the main firmware version, network firmware version, projector model name, and projector serial number.
License	Displays the license information of the computer program.



# Troubleshooting

If you cannot resolve an issue using the information provided in this section, contact your reseller or service center.

## No image appears on screen

The image does not appear on the screen.

### Resolution

- Make sure all the cables and power connections are correctly and securely connected.  
See [Installation](#) on page 19 for more details.
- Check if the Light Status LED is in Green.
- Make sure you have removed the lens cap and the projector is switched on.

## Incorrectly displayed image

The image is partial, is scrolling, or is otherwise incorrectly displayed.

### Resolution

If using a PC:

1. On control panel or IR remote keypad, press **AUTO**.
2. Select **My Computer > Control Panel**.
3. Double-click **Display**.
4. Select the **Settings** tab.
5. Verify your display resolution setting is lower than or equal to WUXGA (1920 × 1200).
6. Click **Advanced Properties**.
7. If the projector is still not projecting the entire image, change the monitor display:
  - a. Verify the resolution setting is lower than or equal to WUXGA (1920 × 1200).
  - b. Switch to the **Monitor** tab.

- c. Click **Change**.
- d. Click **Show all devices**.
- e. Under the SP box, select **Standard monitor types**.
- f. Under the Models box, select the appropriate resolution mode.
- g. Verify that the resolution setting of the monitor display is lower than or equal to WUXGA (1920 × 1200).

If using a Notebook:

1. On control panel or IR remote keypad, press **AUTO**.
2. Adjust resolution of the computer.
3. To send signal out from notebook to projector, press the keys listed below for your Notebook manufacturer (for example, [Fn]+[F4]):

<b>Notebook brand</b>	<b>Function keys</b>
Acer	[Fn]+[F5]
Asus	[Fn]+[F8]
Dell	[Fn]+[F8]
Gateway	[Fn]+[F4]
IBM/Lenovo	[Fn]+[F7]
HP/Compaq	[Fn]+[F4]
NEC	[Fn]+[F3]
Toshiba	[Fn]+[F5]
Mac Apple	System Preference > Display > Arrangement > Mirror display

4. If you experience difficulty changing resolutions or your monitor freezes, restart all equipment including the projector.

## Presentation is not displayed

The screen of the Notebook or PowerBook computer is not displaying your presentation.

### Details

Some Notebook PCs may deactivate their own screens when a second display device is in use. Each has a different method of reactivation.

### Resolution

Refer to your computer manual for information on changing the method of reactivation.

## Unstable or flickering images

The image is unstable or is flickering when projected.

### Resolution

- To correct the pixels, use Pixel Track and Pixel Phase.
- Change the monitor color setting on your computer.

## Vertical flickering bar

The image has a vertical, flickering bar when projected.

### Resolution

- To make an adjustment, use **Auto Image**.
- Check and reconfigure the display mode of your graphic card to make it compatible with the projector.

## Image is out of focus

The image is out of focus on the screen.

### Resolution

- Make sure both lens caps (front and back) are removed.
- Adjust the lens focus to fit the screen.
- Make sure the projection screen is between the required distance.

## Image is stretched

The image is stretched when displaying a 16:9 DVD title.

### Details

When you play anamorphic DVD or 16:9 DVD, the projector shows the best image if the projector display mode is set to 16:9 in the on-screen display.

## Resolution

- If you play 4:3 format DVD titles, change the format to 4:3 in the projector on-screen display.
- If the image is still stretched, adjust the aspect ratio by setting the display format as 16:9 (wide) aspect ratio type on your DVD player. For more details, see [Screen menu](#) on page 40.

## Image is not the correct size

The image is too small or too large.

### Resolution

- Adjust the lens zoom to fit.
- Verify you are using the correct lens.
- Change the position of the projector.

## Connection fail when DHCP on

IP address shows 0.0.0.0 when DHCP is on.

### Resolution

- Make sure RJ45 cable is connected correctly and securely to the projector and the network device.
- Check if there is a DHCP server in this network.
- After checking the steps above, refresh the network setting by turning DHCP off and turning back on.
- Contact your IT engineer if the steps above cannot resolve the network issue.



- Turning off DHCP returns back to default setting if DHCP on fails.

## Connection fail with new IP address

User cannot control the projector after setting up the new IP address manually.

### Resolution

- Make sure RJ45 cable is connected correctly and securely to the projector and the network device.
- Make sure the IP address of projector and the controlling device are set to the same region with different IP addresses.
- Connect the projector directly to the computer. If it is successfully connected, check the network environment.
- Make sure every device has a unique IP address.
- Contact your network engineer if the steps above cannot resolve the network issue.

# Specifications

Learn about the product specifications. Due to continuing research, specifications are subject to change without notice.

## Inputs

The following table details the inputs for GS Series. RB in the Resolution column indicates reduced blanking.

Signal Type	Resolution	Frame rate (Hz)	HDMI	VGA	DVI
PC	640x350	85	•		
	640x400	85	•	•	•
	640x480	59	•		
	640x480	60	•	•	•
	640x480	72	•	•	•
	640x480	75	•	•	•
	640x480	85	•	•	•
	720x400	85	•	•	•
	768x480	60	•		
	768x480	75	•		
	768x480	85	•		
	800x600	50	•		
	800x600	56	•	•	•
	800x600	60	•	•	•
	800x600	72	•	•	•
	800x600	75	•	•	•
	800x600	85	•	•	•
	848x480	50	•		
	848x480	60	•		
	848x480	75	•		

Signal Type	Resolution	Frame rate (Hz)	HDMI	VGA	DVI
PC	848x480	85	•		
	960x600	50	•		
	960x600	60	•		
	960x600	75	•		
	960x600	85	•		
	1024x768	60	•	•	•
	1024x768	75	•	•	•
	1024x768	85	•	•	•
	1064x600	50	•		
	1064x600	60	•		
	1064x600	75	•		
	1064x600	85	•		
	1152x720	50	•		
	1152x720	60	•		
	1152x720	75	•		
	1152x720	85	•		
	1152x864	60	•	•	•
	1152x864	70	•	•	•
	1152x864	75	•	•	•
	1152x864	85	•	•	•
	1280x720	50	•		
	1280x720	60	•	•	•
	1280x720	75	•	•	•
	1280x720	85	•	•	•
	1280x768	60	•	•	•
	1280x768	75	•	•	•
	1280x768	85	•	•	•
	1280x800	50	•	•	•
	1280x800	60	•	•	•
	1280x800	75	•	•	•
	1280x800	85	•	•	•
	1280x960	60	•	•	•
1280x960	75	•	•	•	
1280x960	85	•	•	•	

Signal Type	Resolution	Frame rate (Hz)	HDMI	VGA	DVI
PC	1280x1024	50	•		
	1280x1024	60	•	•	•
	1280x1024	75	•	•	•
	1280x1024	85	•	•	•
	1360x768	50	•		
	1360x768	60	•		
	1360x768	75	•		
	1360x768	85	•		
	1366x768	60	•	•	•
	1400x900	60	•	•	•
	1400x1050	50	•		
	1400x1050	60	•	•	•
	1400x1050	75	•	•	•
	1440x900	60	•	•	•
	1440x900	75	•		
	1600x900	60	•		
	1600x1200	50	•		
	1600x1200	60	•	•	•
	1680x1050	50	•		
	1680x1050	60	•	•	•
	1680x1050	75	•		
	1704x960	50	•		
	1704x960	60	•		
	1728x1080	50	•		
	1728x1080	60	•		
	1864x1050	50	•		
	1864x1050	60	•		
	1920x1080	50	•		
	1920x1080	60	•	•	•
	1920x1200RB	60	•	•	•
1920x1200RB	50	•	•	•	
NTSC	NTSC (M, 4.43)	60			



Signal Type	Resolution	Frame rate (Hz)	HDMI	VGA	DVI
PAL	PAL (B,G,H,I)	50			
	PAL (N)	50			
	PAL (M)	60			
SECAM	SECAM (M)	50			
SDTV	480i	60	•	•	•
	576i	50	•	•	•
EDTV	480p	60	•	•	•
	576p	50	•	•	•
HDTV	1080i	25	•	•	•
	1080i	29	•	•	•
	1080i	30	•	•	•
	720p	50	•	•	•
	720p	59	•	•	•
	720p	60	•	•	•
	1080s	23	•		
	1080s	24	•		
	1080p	23	•	•	•
	1080p	24	•	•	•
	1080p	25	•	•	•
	1080p	29	•	•	•
	1080p	30	•	•	•
	1080p	50	•	•	•
	1080p	59	•	•	•
	1080p	60	•	•	•

## PIP/PBP compatibility

The following table details the PIP/PBP compatibility.

<b>PIP/PBP Matrix</b>	<b>VGA</b>	<b>DVI-D</b>	<b>HDMI-2</b>	<b>HDMI-1</b>	<b>HDBaseT</b>
VGA	-	•	•	•	•
DVI-D	•	-	•	-	-
HDMI-2	•	•	-	•	•
HDMI-1	•	-	•	-	-
HDBaseT	•	-	•	-	-

- Dot (•): PIP/PBP combinations are enabled.
- Dash (-): PIP/PBP combinations are disabled.

## Key features

- HD 0.65" 1920 × 1080 resolution or WUXGA 0.67" 1920 × 1200 resolution
- Projection lens compatibility:
  - Horizontal offset ranges: +/-30%
  - Vertical offset ranges: +/-100% (WUXGA) and +/-120% (HD)  
Measurements are based on industry standards where offset is calculated as a ratio of the number of pixels shifted up/ down to half the image size.
- SNMP traps and email notifications
- 10-bit image processor electronics with modular design
- All video formats can be resized to full screen either horizontally or vertically while maintaining aspect ratio
- The projector can be operated using any of the following:
  - The built-in keypad, an infrared (IR) remote control, a wired remote control, a PC/device using serial communications (Ethernet or RS232)
  - A Web page via Ethernet
- Weight:
  - Maximum product weight (with lens removed): 16.5 kg (36 lbs)
- Built-In keypad

## List of components

This projector comes with all the items listed below. Check to make sure your package is complete. If anything is missing, contact your dealer.

- IR remote control (P/N: 003-004468-01)
- Power cords supplied with the projector:
  - UK/Korea/Russia
  - North America
  - Europe
  - Australia/New Zealand
  - Japan
  - India
  - South Africa
- DVI to HDMI dongle
- User manual (USB)

Due to the difference in applications for each country, some regions may have different accessories.

The following accessories are available for the projector:

- Cable Cover GS White (P/N: 140-106108-XX)
- Cable Cover GS Black (P/N: 140-106119-XX)
- Standard Lens 1.22 - 1.53 (P/N: 140-132107-XX)
- Optional Lens 0.95 - 1.22 (P/N: 140-101103-01)
- Optional Lens 1.52 - 2.89 (P/N: 140-102104-01)
- Optional Lens 0.75 - 0.95 (P/N: 140-119102-XX)
- Optional Lens 2.90 - 5.50 (P/N: 140-107109-XX)
- Optional Lens 1.22-1.52 (P/N: 140-131106-XX)
- Optional Lens 0.36 (P/N: 140-133108-XX)
- Christie One Mount (P/N: 108-506102-XX)
- One Mount Extender Rod (P/N: 121-125109-XX)
- One Mount Rigging Kit (P/N: 121-126100-XX)

## Physical specifications

Learn the dimensions and weight of the projector.

Description	Dimensions
<b>Projector size</b>	
Overall size (L x W x H) (excluding lens, feet)	456 mm (18.0 in) x 505 mm (19.9 in) x 190 mm (7.5 in)
Overall size, shipping without lens (L x W x H) (includes packaging)	596 mm (23.5 in) x 626 mm (24.6 in) x 341 mm (13.4 in)
<b>Projector Weight</b>	
Without lens	16.5 kg (36 lbs)
Shipping without lens (includes packaging)	22.3 kg (49.2 lbs)
<b>Operating position</b>	
360 degree front to back and portrait capable	Free orientation and no tilt range constraint.

## Physical operating environment

Provides specifications for the operating environment.

- Operating: 5°C to 40°C
  - 5 to 40 degrees C (0 to 2500 ft)
  - 5 to 35 degrees C (2500 to 5000 ft)
  - 5 to 30 degrees C (5000 to 10000 ft)
- Storage temperature range: -10°C to 60°C
- Humidity range: 10% to 85% RH (maximum), non condensing
- Storage humidity range: 5% to 90% RH (maximum), non condensing
- Operating altitude: 10,000 ft maximum

## Power requirements

Learn the power requirements for the projector.

Parameter	Requirement
<b>Rated voltage</b>	
Input	100-240V
<b>Rated current</b>	
Input	7A
Line frequency	50/60Hz
<b>AC input coupler</b>	
Inrush current	76A max
<b>Maximum power consumption</b>	
Input	650W
<b>Maximum power consumption, ECO mode</b>	
Input	470W
<b>Maximum power consumption, WLAN mode</b>	
Input	< 8.0W
<b>Maximum power consumption, Standby mode</b>	
Input	< 0.5W

## Regulatory

This product conforms to the following regulations related to product safety, environmental requirements and electromagnetic compatibility (EMC).

### Safety

- CSA C22.2 No. 60950-1
- UL 60950-1
- IEC 60950-1
- EN 60950-1

### Laser Safety

- IEC 60825-1
- IEC 62471
- FDA CDRH CFR 1040.10

- FDA CDRH CFR 1040.11

## Electro-Magnetic Compatibility

### Emissions

- FCC CFR47, Part 15, Subpart B/ANSI C63.4, Class A - Unintentional Radiators
- CISPR32/EN55032 Class A - Information Technology Equipment
- ICES/NMB003 (A) - Information Technology Equipment

### Immunity

- CISPR 24/EN55024 EMC Requirements - Information Technology Equipment

## Environmental

- The product conforms to:
  - EU Directive (2011/65/EU) on the restriction of the use of certain hazardous substances (RoHS) in electrical and electronic equipment and the applicable official amendment(s).
  - EU Regulation (EC) No. 1907/2006 on the registration, evaluation, authorization and restriction of chemicals (REACH) and the applicable official amendment(s).
  - EU Directive (2012/19/EU) on waste and electrical and electronic equipment (WEEE) and the applicable official amendment(s).
  - China Ministry of Information Industry Order No.39 (02/2006) on the control of pollution caused by electronic information products, the hazardous substances concentration limits (SJ/T11363-2006), and the applicable product marking requirement (SJ/T11364-2006).

## Marking

- This product conforms to all relevant Canadian, US, and European directives, standards, safety, health and environmental concerns. International packaging recycling marks conform to:
  - EU Directive (2012/19/EU) on waste and electrical and electronic equipment (WEEE).
  - EU Directive (94/62/EC) on packaging and packaging waste.
  - China packaging recycling mark standard (GB18455-2001).

## Federal Communications Commission (FCC) warning

- A shielded-type power cord is required in order to meet FCC emission limits and also to prevent interference to the nearby radio and television reception. It is essential that only the supplied power cord be used.
- Use only shielded signal cables to connect I/O devices to this equipment.

## On-screen display tree

The following table provides the on-screen display menu.

Level 1	Level 2	Level 3 (Or List)	Level 4 (Or List)	Level 5 (Or List)	Level 6 (Or List)	Default
Picture	Picture Settings	Bright				Depends on signal type.
		Presentation				
		Film				
		REC709				
		Blending				
		DICOM SIM.				
		User				
	Wall color	White				White
		Gray 130				
	Brightness	0 ~ 100				Depends on color mode.
	Contrast	0 ~ 100				Depends on color mode.
	Sharpness	0 ~ 10				5
	Color	0 ~ 100				VGA component signal only.
	TINT	0 ~ 100				VGA component signal only (white color).
	Gamma	Video				Depend on color mode.
		Film				
		Bright				
		CRT				
		DICOM				
	White Peaking	0 ~ 100				
Color Temp	Warm				Bright	
	Bright					
	Cool					



Level 1	Level 2	Level 3 (Or List)	Level 4 (Or List)	Level 5 (Or List)	Level 6 (Or List)	Default		
Picture	Color Wheel Speed	2X				3X		
		3X						
	HSG Adjustment	Red	Hue			1 ~ 199		
			Saturation			0 ~ 199		
			Gain			1 ~ 199		
		Green	Hue			1 ~ 199		
			Saturation			0 ~ 199		
			Gain			1 ~ 199		
		Blue	Hue			1 ~ 199		
			Saturation			0 ~ 199		
			Gain			1 ~ 199		
		Cyan	Hue			1 ~ 199		
			Saturation			0 ~ 199		
			Gain			1 ~ 199		
		Magenta	Hue			1 ~ 199		
			Saturation			0 ~ 199		
			Gain			1 ~ 199		
		Yellow	Hue			1 ~ 199		
			Saturation			0 ~ 199		
			Gain			1 ~ 199		
		White Gain	Red			1 ~ 199		
			Green			0 ~ 199		
			Blue			1 ~ 199		
			Reset to Default					
		Contrast Enhancement	Off					Off
			Dynamic Black					
	Real Black							
	Color Space	Auto					Auto	
		RGB(0-255)						
		RGB(16-235)						
		YUV						

Level 1	Level 2	Level 3 (Or List)	Level 4 (Or List)	Level 5 (Or List)	Level 6 (Or List)	Default	
Screen	Size Presets	Auto					
		4:3					
		16:9					
		16:10					
	Pixel Phase	0 ~ 100					
	Pixel Track	0 ~ 100					
	Horz Position	0 ~ 100					
	Vert Position	0 ~ 100					
	Digital Horz Zoom	100% to 200%	0 ~ 10			0	
	Digital Vert Zoom	100% to 200%	0 ~ 10			0	
	Digital Horz Shift		0 ~ 100			50	
	Digital Vert Shift		0 ~ 100			50	
	Ceiling Mount	Off				Auto	
		On					
		Auto					
	Rear Projection	Off				Off	
		On					
	Geometric Correction	H. Keystone	0~40				20
			V. Keystone	0~40			
		4 Corners	Top Left Horz Adjust				
			Top Left Vert Adjust				
			Top Right Horz Adjust				
			Top Right Vert Adjust				
			Bottom Left Horz Adjust				
			Bottom Left Vert Adjust				
			Bottom Right Horz Adjust				
	Bottom Right Vert Adjust						

Level 1	Level 2	Level 3 (Or List)	Level 4 (Or List)	Level 5 (Or List)	Level 6 (Or List)	Default
Screen	Geometric Correction	Grid Color	Purple			Green
			Green			
		Reset	Yes			
			No			
		PC Mode	Off			
			On			
	PIP-PBP Settings	Function	Off			Off
			PBP			
			PIP			
		Main Source	VGA			Current Source.
			HDMI-1			
			HDMI-2			
			DVI			
			HDBaseT			
		Sub Source	VGA			Depends on current source.
			HDMI-1			
			HDMI-2			
			DVI			
			HDBaseT			
		Location	Top Left			Top Left
			Top Right			
			Bottom Left			
			Bottom Right			
		Size	Small			Medium
			Medium			
			Large			
		Swap				
Input key	Change Sources					
	List all Sources					
	Auto Source					
Auto Image	Normal				Wide	
	Wide					

<b>Level 1</b>	<b>Level 2</b>	<b>Level 3 (Or List)</b>	<b>Level 4 (Or List)</b>	<b>Level 5 (Or List)</b>	<b>Level 6 (Or List)</b>	<b>Default</b>
Screen	Source Info	Active Source				
		Signal Format				
		Aspect Ratio				
		Resolution				
		Vert Refresh				
		Horz Refresh				
		Pixel Clock				
		Sync Type				
		Color Space				
		PIP/PBP (When PIP/PBP active)				

Level 1	Level 2	Level 3 (Or List)	Level 4 (Or List)	Level 5 (Or List)	Level 6 (Or List)	Default
Settings	Language	English 0				English
		Simplified Chinese 1				
		French 2				
		German 3				
		Italian 4				
		Japanese 5				
		Korean 6				
		Russian 7				
		Spanish 8				
	Menu Location	Left Top				Left Top
		Right Top				
		Center				
		Left Bottom				
		Right Bottom				
	LAN (Standby)	0.5W mode				Communication
		Communication mode				
	Test Pattern	None				None
		Grid				
White						
Black						
Checkerboard						
Color Bars						
Settings	Direct Power On	On				Off
		Off				
	Hot-Key settings	Blank Screen				Blank Screen
		Aspect Ratio				
		Freeze Screen				
		Projector Info				
	Reset to Default	Yes				
		No				
	Service					

Level 1	Level 2	Level 3 (Or List)	Level 4 (Or List)	Level 5 (Or List)	Level 6 (Or List)	Default	
Light source	Light Source Mode	Constant Power				Constant Power	
		Constant Intensity					
		ECO 1 (80%)					
		ECO 2 (50%)					
	Constant Power	0 to 99 (30% to 100%)				99	
Light Source Info	Light Source Info	Total Projector Hours					
		LD Hours					
Options	Splash Screen	Factory Logo				Default Value	
		Blue					
		Black					
		White					
	Auto shutdown	0~ 120 (one step: 5 mins)				0	
	Sleep Timer	0~990 (one step: 10 mins )				0	
	Lens settings	Lens settings	Focus	Command			
			Zoom	Command			
			Lens Shift	Command			
			Lock lens motors	Allow			
Locked							
Lens calibration	Command						
High Altitude	High Altitude	On				Off	
		Off					

Level 1	Level 2	Level 3 (Or List)	Level 4 (Or List)	Level 5 (Or List)	Level 6 (Or List)	Default	
Options	PIN Protect	Security	On			Off	
			Off				
		Change Password					
	Remote Settings	Top		Off			On
				On			
		Front		Off			On
				On			
		HDBaseT		Off			On
				On			
	Projector Address		0 ~ 9				0
	Information Hide			On			Off
				Off			
	Backlight Preferences	Keypad Backlight		Always On			Always On
				Always Off			
		Status LED		Always On			Always On
				Always Off			
			Warning/Errors only				
	Information			Model Name			
				Serial Number			
				Native Resolution			
				MCU FW			
				DDP FW			
M9813 FW							
Motor FW							
PW808 FW							
Main Input							
Main Signal Format							
Main Pixel Clock							
Main Sync Type							
Main Horz Refresh							

Level 1	Level 2	Level 3 (Or List)	Level 4 (Or List)	Level 5 (Or List)	Level 6 (Or List)	Default
Options	Information	Main Vert Refresh				
		PIP/PBP Input				
		PIP/PBP Signal Format				
		PIP/PBP Pixel Clock				
		PIP/PBP Sync Type				
		PIP/PBP Horz Refresh				
		PIP/PBP Vert Refresh				
		Light Source Power				
		Total Projector Hours				
		Light Source Hours				
		Standby Mode				
		Lens Lock Settings				
		IP Address				
		DHCP				
		System Temperature				
3D	3D	On				Auto
		Auto				
	3D Invert	On				Off
		Off				
	3D Format	Frame Packing				Depends on input signal. If an HDMI source with AVINFO data existed then display 3D mode automatically.
		Side-by-Side (Half)				
		Top and Bottom				
	Frame Sequential (635-GS)					
1080p @ 24	96Hz				144Hz	
	144Hz					



Level 1	Level 2	Level 3 (Or List)	Level 4 (Or List)	Level 5 (Or List)	Level 6 (Or List)	Default
3D	3D Sync Out	To emitter				To Emitter
		To Next Projector				
	Frame Delay	1 ~ 200				
	L/R Reference	1st Frame				
Field GPIO						
Communications	LAN	DHCP				By set
		IP Address				
		Subnet Mask				
		Default Gateway				
		MAC Address				
	Network	Projector Name				By set
		Show Network Messages				
		Restart Network...				
		Network Factory Reset...				
	Serial Port Baud Rate	1200				115200
		2400				
		4800				
		9600				
		14400				
		19200				
		38400				
		57600				
		115200				
	Serial Port Echo	Off				Off
		On				
Serial Port Path	RS232				RS232	
	HDBaseT					

## Corporate offices

---

USA – Cypress  
ph: 714-236-8610

Canada – Kitchener  
ph: 519-744-8005

## Consultant offices

---

Italy  
ph: +39 (0) 2 9902 1161

## Worldwide offices

---

Australia  
ph: +61 (0) 7 3624 4888

Brazil  
ph: +55 (11) 2548 4753

China (Beijing)  
ph: +86 10 6561 0240

China (Shanghai)  
ph: +86 21 6278 7708

Eastern Europe and  
Russian Federation  
ph: +36 (0) 1 47 48 100

France  
ph: +33 (0) 1 41 21 44 04

Germany  
ph: +49 2161 664540

India  
ph: +91 (080) 6708 9999

Japan  
ph: 81-3-3599-7481

Korea (Seoul)  
ph: +82 2 702 1601

Republic of South Africa  
ph: +27 (0)11 510 0094

Singapore  
ph: +65 6877-8737

Spain  
ph: + 34 91 633 9990

United Arab Emirates  
ph: +971 4 3206688

United Kingdom  
ph: +44 118 977 8000



For the most current technical documentation,  
please visit [www.christiedigital.com](http://www.christiedigital.com)

**CHRISTIE®**