

INSTALLATION INSTRUCTIONS

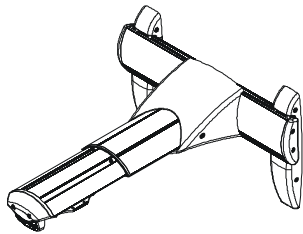

WM-210

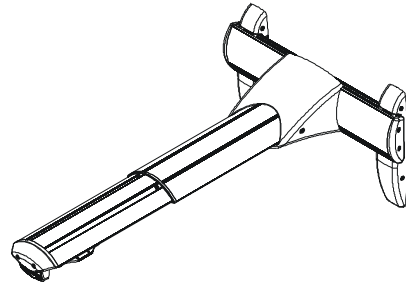
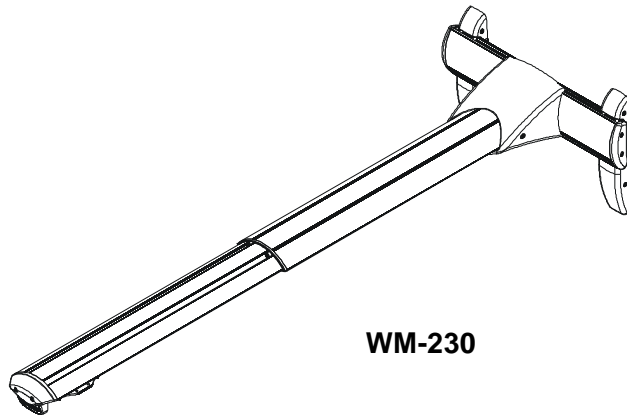

WM-220



WM-230

Dual Stud Short Throw Wall Mounts

DISCLAIMER

Milestone AV Technologies and its affiliated corporations and subsidiaries (collectively "Milestone"), intend to make this manual accurate and complete. However, Milestone makes no claim that the information contained herein covers all details, conditions or variations, nor does it provide for every possible contingency in connection with the installation or use of this product. The information contained in this document is subject to change without notice or obligation of any kind. Milestone makes no representation of warranty, expressed or implied, regarding the information contained herein. Milestone assumes no responsibility for accuracy, completeness or sufficiency of the information contained in this document.

Chief® is a registered trademark of Milestone AV Technologies. All rights reserved.

! IMPORTANT WARNINGS AND CAUTIONS!

! WARNING: A WARNING alerts you to the possibility of serious injury or death if you do not follow the instructions.

! CAUTION: A CAUTION alerts you to the possibility of damage or destruction of equipment if you do not follow the corresponding instructions.







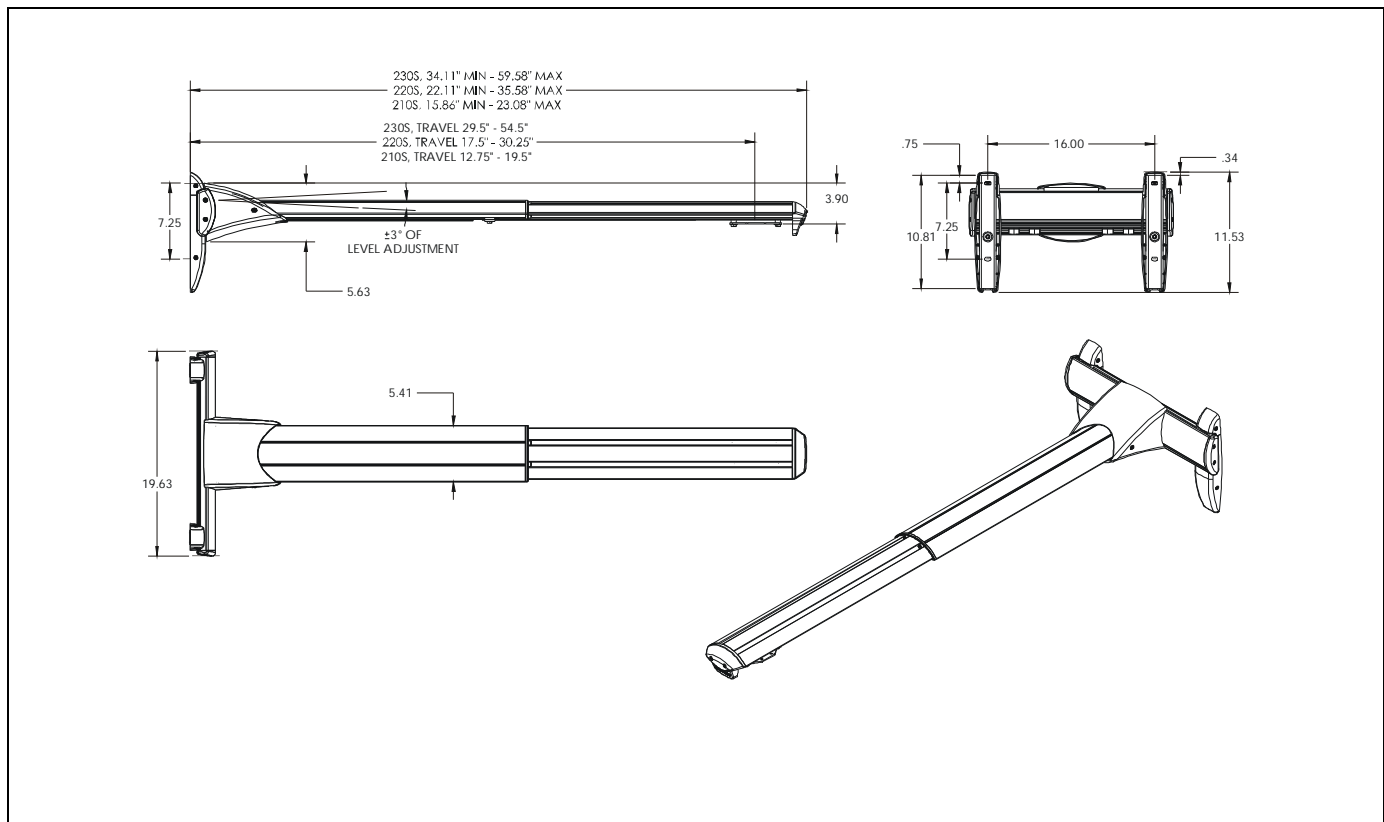

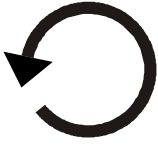

! WARNING: Failure to read, thoroughly understand, and follow all instructions can result in serious personal injury, damage to equipment, or voiding of factory warranty! It is the installer's responsibility to make sure all components are properly assembled and installed using the instructions provided.

! WARNING: Failure to provide adequate structural strength for this component can result in serious personal injury or damage to equipment! It is the installer's responsibility to make sure the structure to which this component is attached can support five times the combined weight of all equipment. Reinforce the structure as required before installing the component. Exceeding the weight capacity can result in serious personal injury or damage to equipment! It is the installer's responsibility to make sure the combined weight of all components attached to the short throw projector mounts up to (and including) the projector does not exceed 50 lbs (22.68 kg) for the WM210 or the WM220 or 25 lbs (11.34 kg) for the WM230.

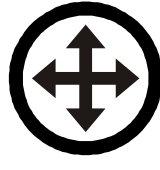
DIMENSIONS



LEGEND

	<p>Tighten Fastener Apretar elemento de fijación Befestigungsteil festziehen Apertar fixador Serrare il fissaggio Bevestiging vastdraaien Serrez les fixations</p>		<p>Pencil Mark Marcar con lápiz Stiftmarkierung Marcar com lápis Segno a matita Potloodmerkteken Marquage au crayon</p>
	<p>Loosen Fastener Aflojar elemento de fijación Befestigungsteil lösen Desapertar fixador Allentare il fissaggio Bevestiging losdraaien Desserrez les fixations</p>		<p>Drill Hole Perforar Bohrloch Fazer furo Praticare un foro Gat boren Percez un trou</p>
	<p>Phillips Screwdriver Destornillador Phillips Kreuzschlitzschraubendreher Chave de fendas Phillips Cacciavite a stella Kruiskopschroevendraaier Tournevis à pointe cruciforme</p>		<p>Adjust Ajustar Einstellen Ajustar Regolare Afstellen Ajuster</p>
	<p>Open-Ended Wrench Llave de boca Gabelschlüssel Chave de bocas Chiave a punte aperte Steeksleutel Clé à fourche</p>		<p>Remove Quitar Entfernen Remover Rimuovere Verwijderen Retirez</p>
	<p>By Hand A mano Von Hand Com a mão A mano Met de hand À la main</p>		<p>Optional Opcional Optional Opcional Opzionale Optie En option</p>
	<p>Hex-Head Wrench Llave de cabeza hexagonal Sechskantschlüssel Chave de cabeça sextavada Chiave esagonale Zeskantsleutel Clé à tête hexagonale</p>		<p>Security Wrench Llave de seguridad Sicherheitsschlüssel Chave de segurança Chiave di sicurezza Veiligheidssleutel Clé de sécurité</p>

TOOLS REQUIRED FOR INSTALLATION

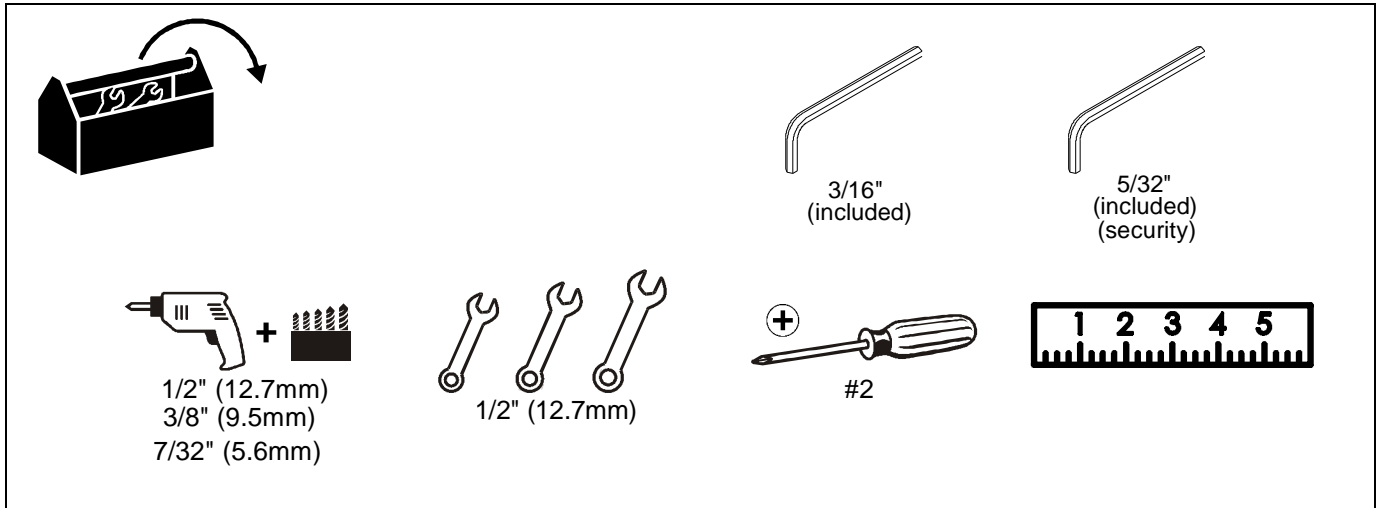

PARTS

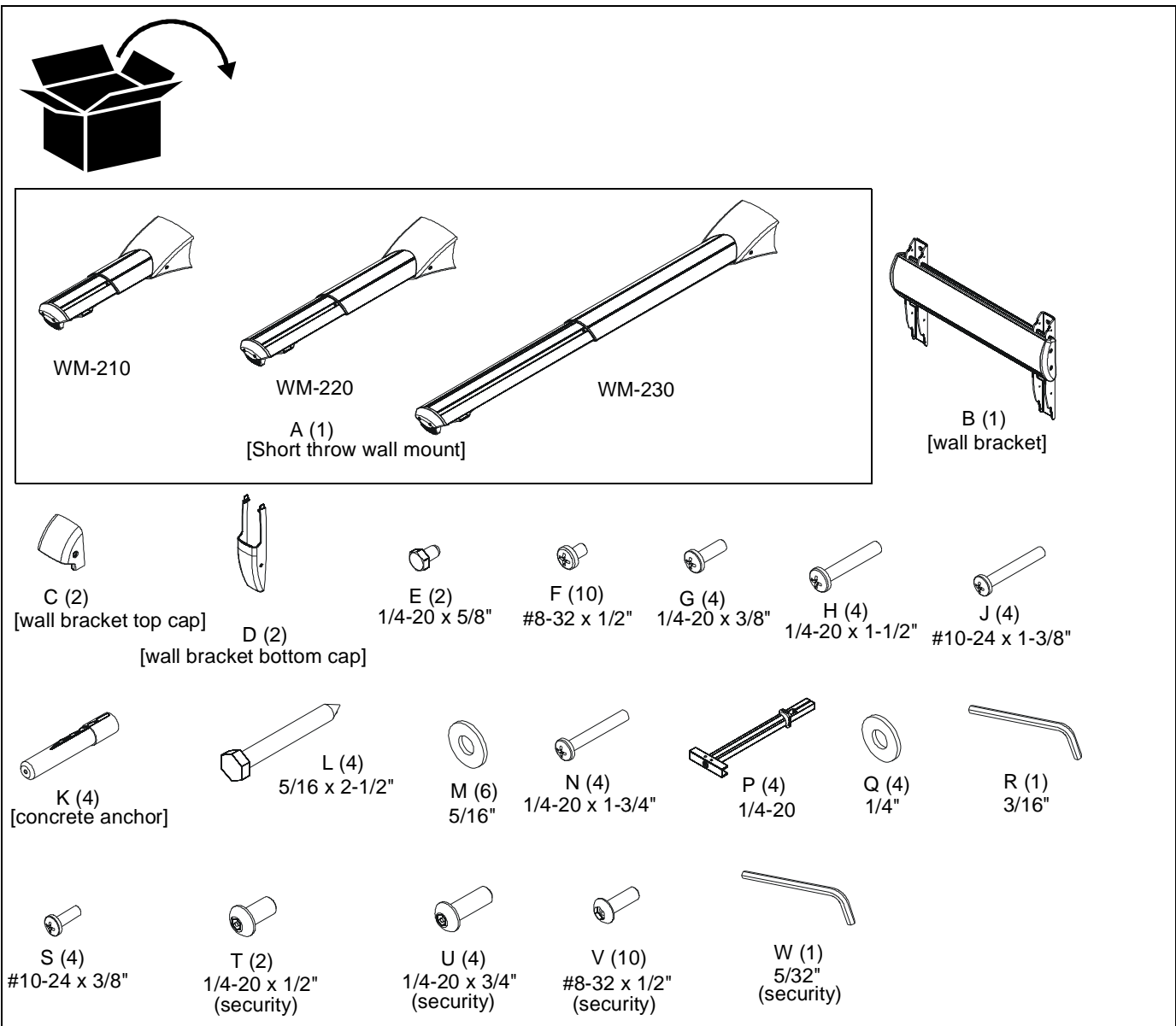

Site Requirements



WARNING: IMPROPER INSTALLATION CAN LEAD TO EQUIPMENT FALLING CAUSING SERIOUS PERSONAL INJURY OR DAMAGE TO EQUIPMENT! The figure below identifies the minimum requirements for installation of display mounts onto a steel stud structure. If the structure or its components do not meet these requirements contact the mount manufacturer for specific instructions before attempting installation. It should also be noted that no other equipment should be mounted to the same stud.

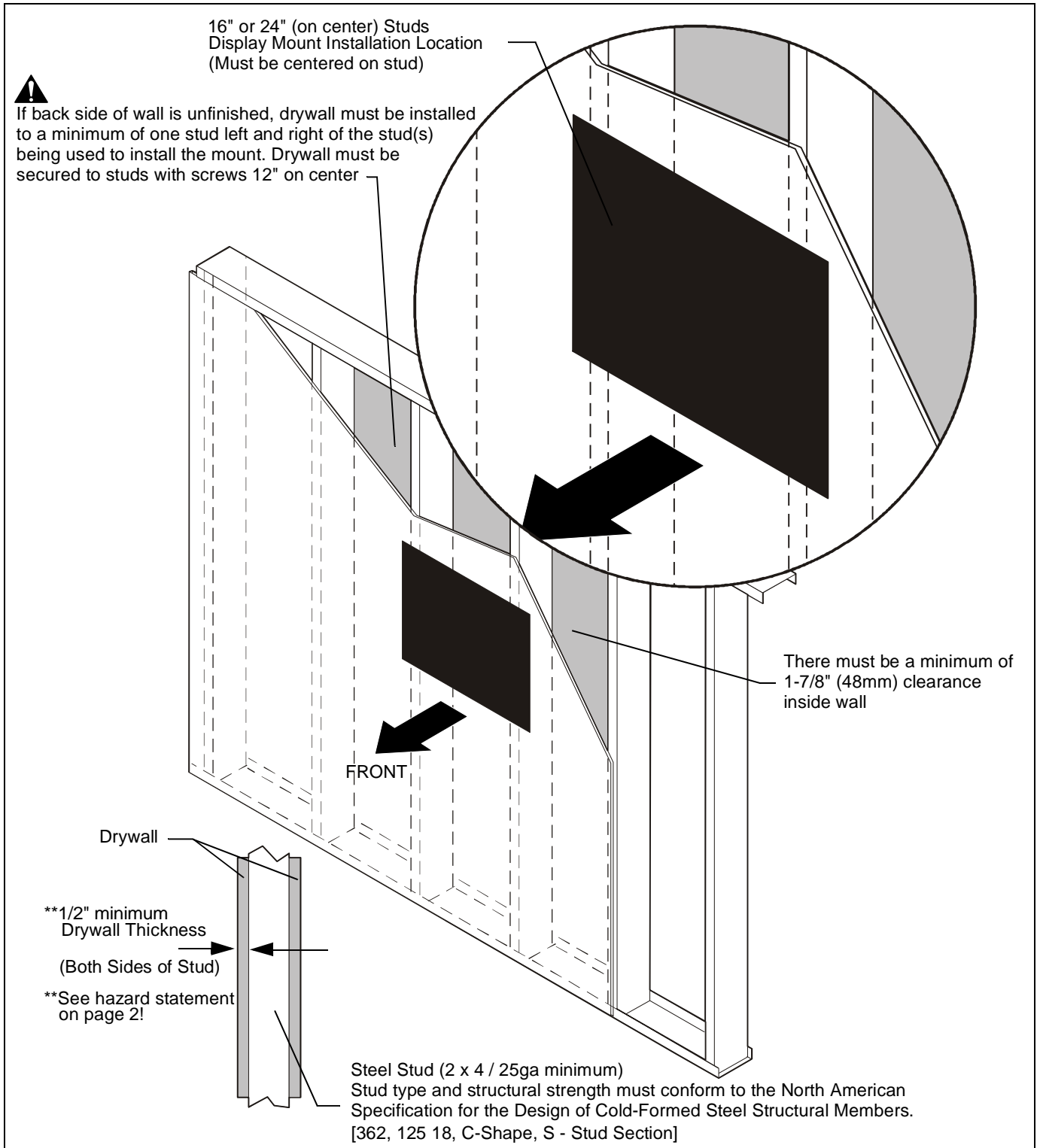

Assembly and Installation

The WM-210, 220 and 230 short throw projector mounts can be mounted to concrete, concrete block, wood studs or steel studs. They can be mounted to studs up to 16" apart. For studs more than 16" apart, the WMAL24 accessory (not evaluated and tested by Underwriters Laboratories®) can be used to mount projector.

Mounting Wall Bracket

Concrete or Concrete Block

1. Determine mounting location on wall.
2. Using mounting bracket (B) as a template, mark four holes at the holes in bracket. (See Figure 1)
3. Drill four 3/8" holes at marked locations in wall. (See Figure 1)

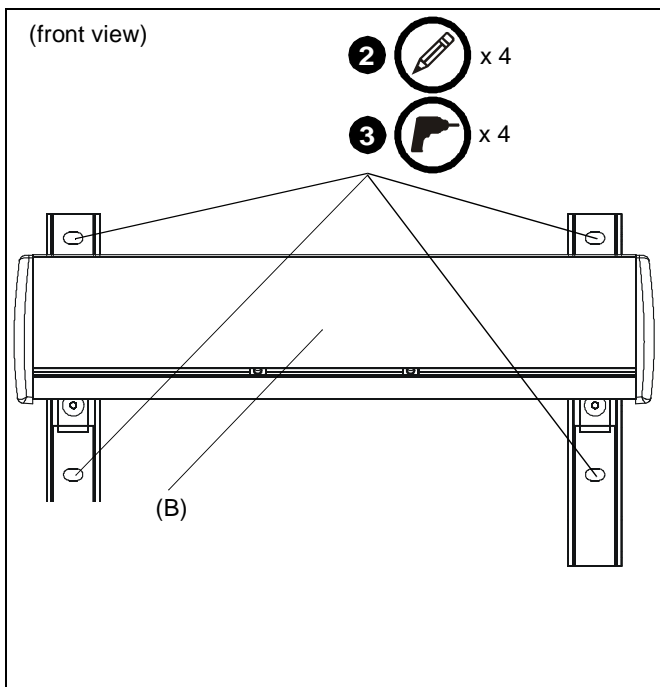

Figure 1

4. Install four concrete anchors (K) into drilled holes. (See Figure 2)
5. Install four 5/16 x 2-1/2" hex head lag screws (L) through four 5/16" washers (M), outer holes of mounting bracket (B) and into concrete anchors (K). (See Figure 2)

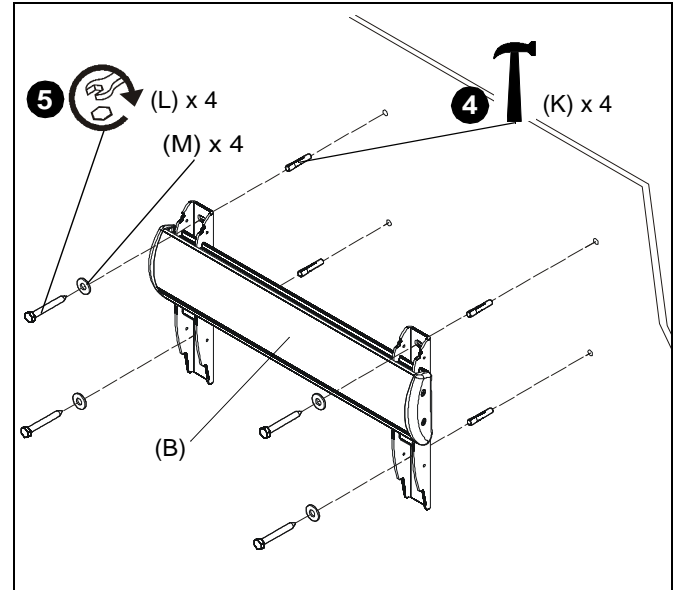

Figure 2

Wood Studs

1. Determine mounting location on wall. Use a stud finder to locate studs. For studs less than 16" apart, mounting brackets will have to be adjusted. See Adjustments section for details.
2. Draw a dotted line down the center of the studs to be used for mounting.
3. Line up inner four holes on mounting bracket (B) with center of studs at desired mounting location. (See Figure 3)
4. Using mounting bracket (B) as a template, mark four holes at the holes in bracket. (See Figure 3)
5. Drill four 7/32" holes at marked locations in wall. (See Figure 3)

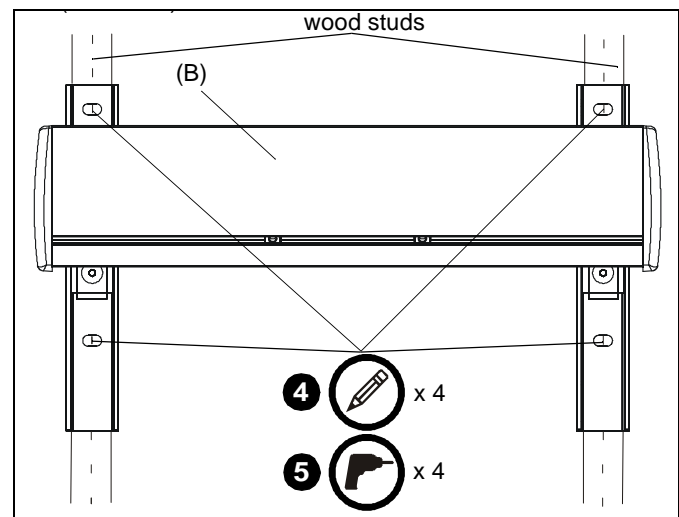

Figure 3

6. Install four 5/16 x 2-1/2" hex head lag screws (L) through four 5/16" washers (M), holes of mounting bracket and into drilled holes. (See Figure 4)

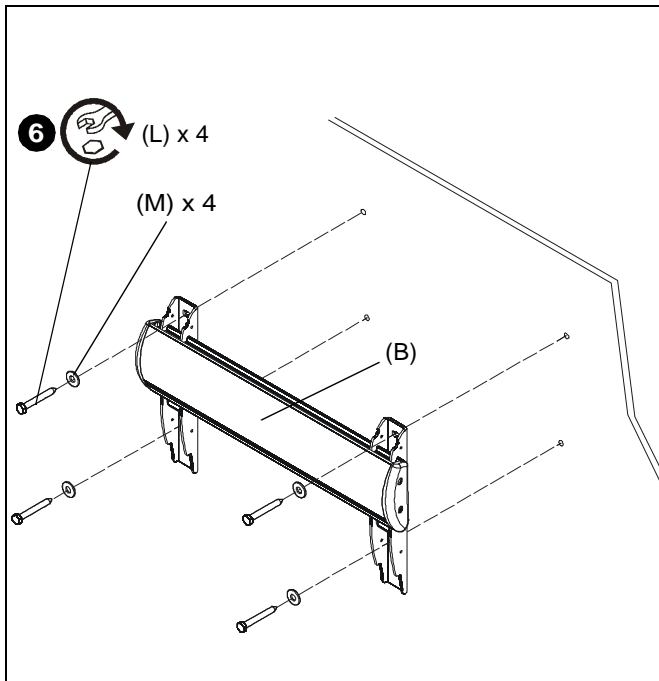

Figure 4

Steel Studs

IMPORTANT ! : See Site Requirements section before proceeding with Steel Studs installation to ensure installation site meets requirements! The drywall must have a minimum thickness of 1/2"!

1. Determine mounting location on wall. Use stud finder to locate steel studs. For studs less than 16" apart, mounting brackets will have to be adjusted. See Adjustments section for details.
2. Draw a dotted line down the center of the studs to be used for mounting.
3. Line up four holes on mounting bracket with center of studs at desired mounting location. (See Figure 5)
4. Using mounting bracket as a template, mark four holes at the inner four holes in bracket. (See Figure 5)
5. Drill four 1/2" holes at marked locations in wall. (See Figure 5)

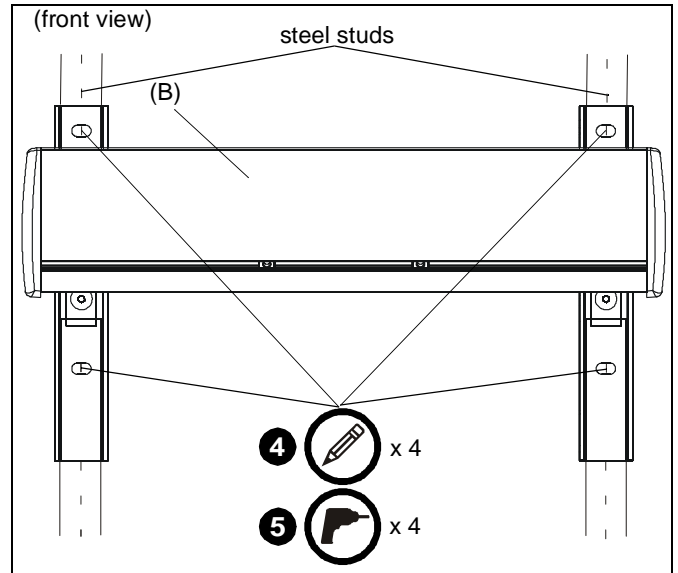

Figure 5

6. Hold metal channel on anchor (P) flat alongside plastic straps and slide channel through hole. (See Figure 6)

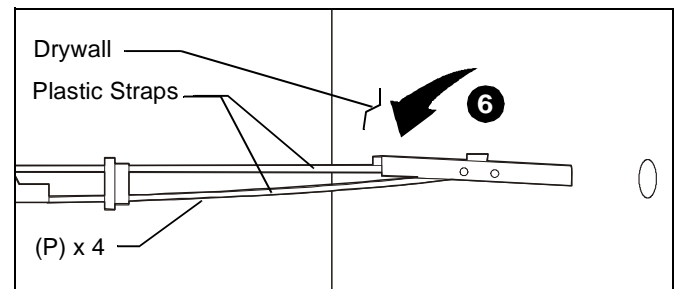

Figure 6

7. Holding plastic straps on anchor (P), pull anchor away from wall until channel rests flush behind wall making sure anchor channel is positioned vertically on stud. (See Figure 7)
8. Slide plastic cap on anchor (P) towards wall until flange of cap is flush with wall. (See Figure 7)

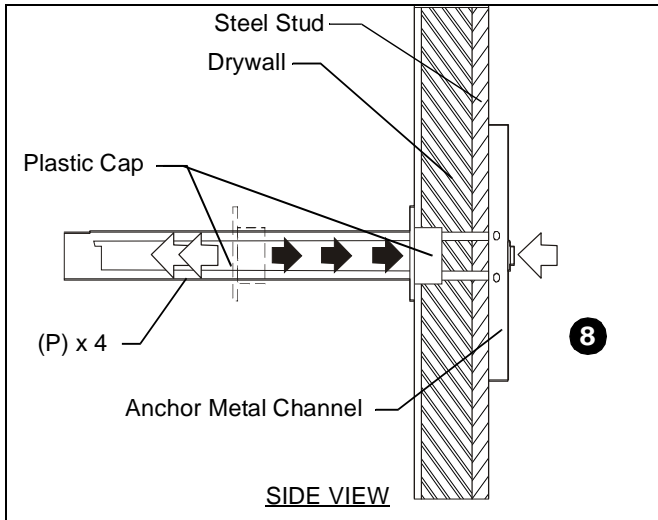

Figure 7

9. Snap off plastic straps on anchor at wall by pushing side to side, snapping off straps level with flange of plastic cap. (See Figure 8)
10. Repeat steps 7 through 9 for each mounting hole.

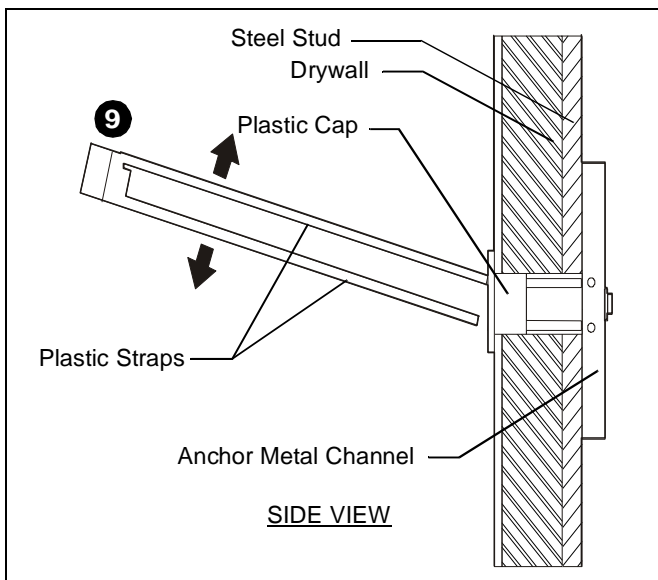

Figure 8

11. Place wall bracket over anchors and align mounting holes in display mount with holes in anchors. (See Figure 9)
12. Insert 1/4-20 x 1-3/4" Phillips pan head screws (N) through 1/4" washer (Q), corresponding mounting hole on wall bracket and into anchor (P) and tighten until flush against mount. DO NOT overtighten! (See Figure 9)
13. Repeat steps 11 through 12 for remaining 3 mounting holes.

⚠ WARNING: IMPROPER INSTALLATION CAN LEAD TO EQUIPMENT FALLING CAUSING SERIOUS PERSONAL INJURY OR DAMAGE TO EQUIPMENT! Overtightening of mounting hardware can damage the steel studs. DO NOT overtighten mounting hardware!

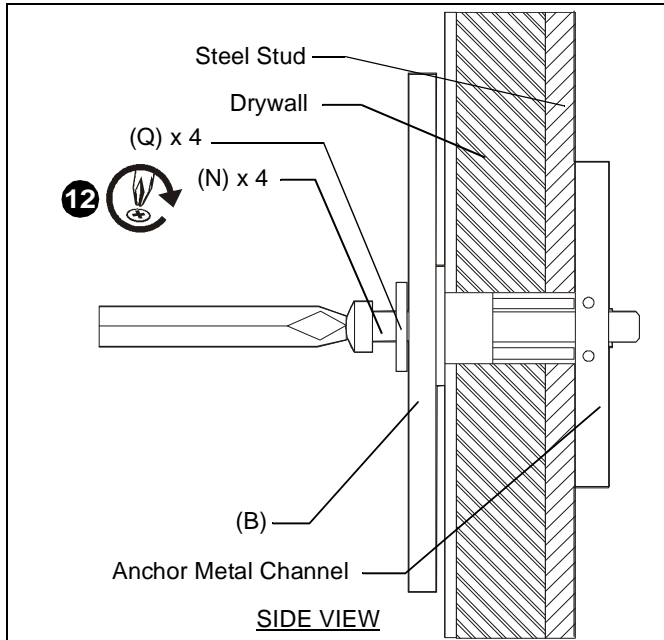

Figure 9

Installation to Wall Bracket

1. Lift short throw projector arm (A) up to mounting bracket (B) and hook top plate onto cross bracket on mounting bracket. (See Figure 10)

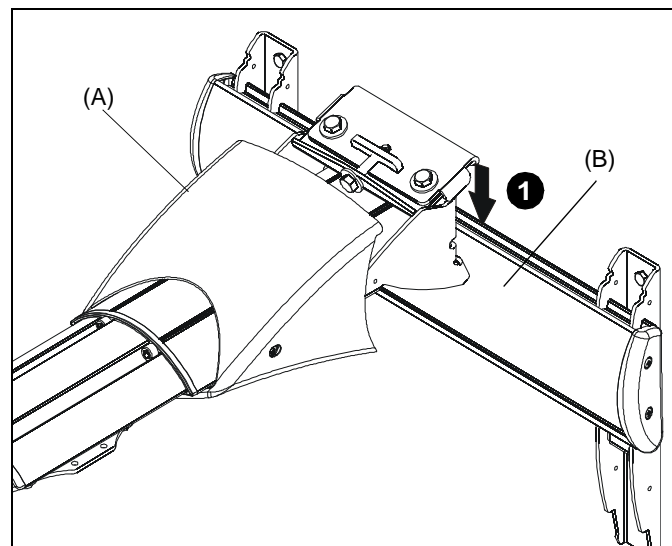

Figure 10

2. Slide lower plate onto cross bracket on mounting bracket. (See Figure 11)

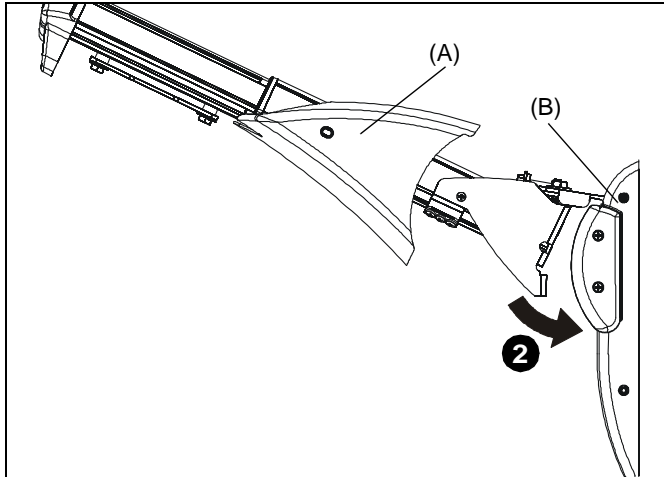

Figure 11

3. Install two 1/4-20 x 5/8" hex head bolts (E) through holes on short throw projector arm (A) and into sliding nuts on mounting bracket (B). **DO NOT TIGHTEN SCREWS AT THIS POINT!** (See Figure 12)

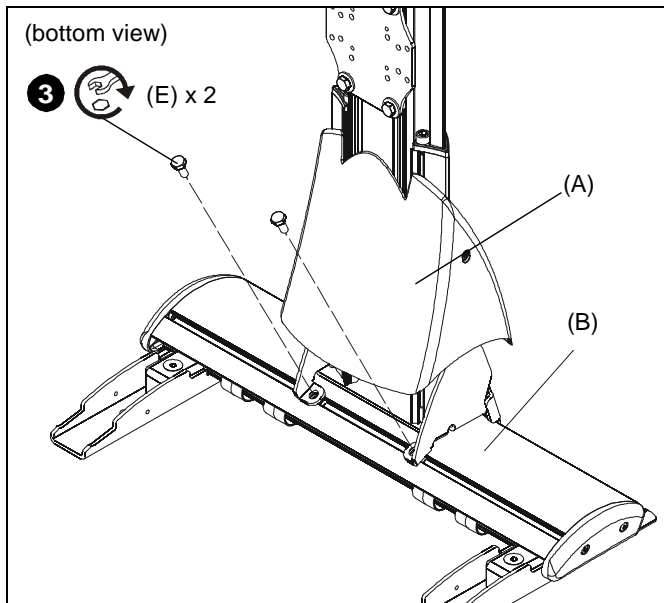

Figure 12

4. Loosen two bolts on either side of pitch adjustment screw. (See Figure 13)
5. Adjust pitch adjustment screw until mount is at desired pitch level. Turn clockwise to raise mounting level or turn counterclockwise to lower mounting level. (See Figure 13)
6. Tighten two bolts on either side of pitch adjustment screw. (See Figure 13)

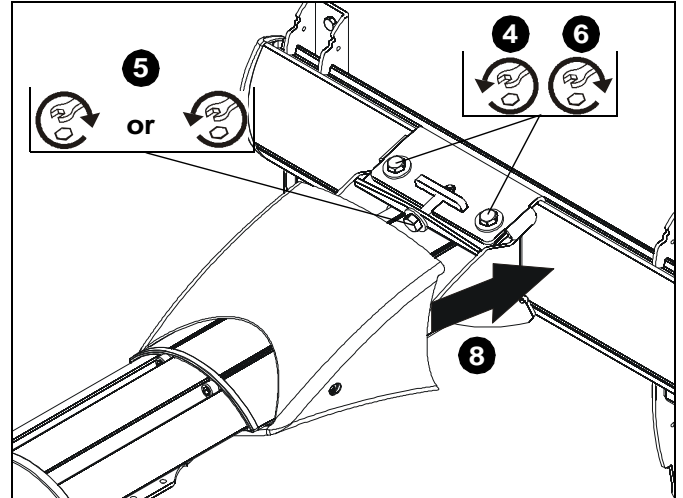

Figure 13

7. Tighten two bolts installed in Step 3. (See Figure 12)
8. Slide outer cover of mount (A) back against mounting bracket. (See Figure 13)
9. Install two #8-32 x 1/2" Phillips pan machine screws (F) through holes on sides of outer cover. (See Figure 14)

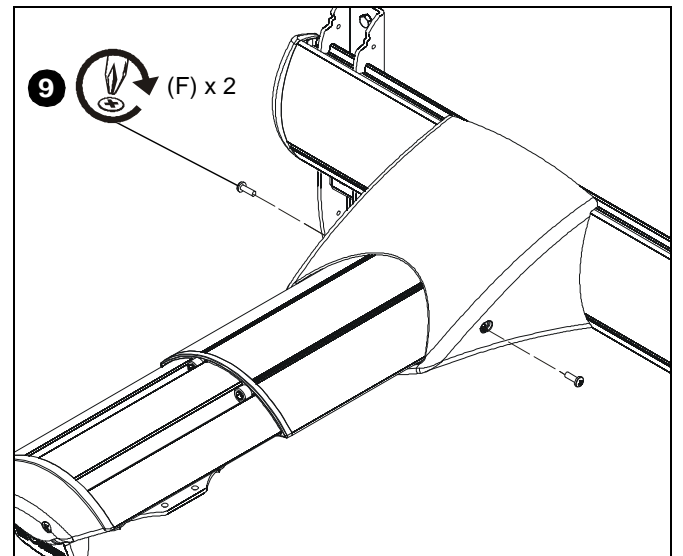

Figure 14

Projector Installation



WARNING: Exceeding the weight capacity can result in serious personal injury or damage to equipment! It is the installer's responsibility to make sure the combined weight of all components attached to the short throw projector mounts up to (and including) the projector does not exceed 50 lbs (22.68 kg) for the WM210 or the WM220 or 25 lbs (11.34 kg) for the WM230.

Refer to Figure 15 to determine hole configuration to use for each specific projector mount.

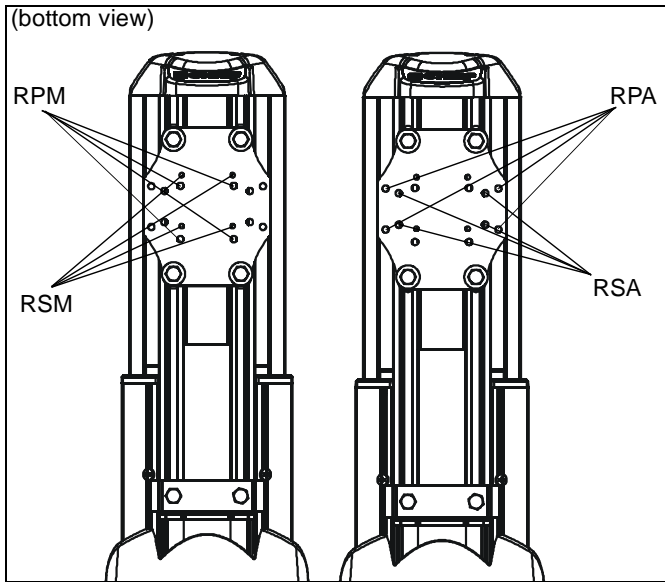

Figure 15

RPM Installation

1. Line up mounting holes on RPM mount with corresponding holes on projector mounting plate. (See Figure 15)
2. Install four 1/4-20 x 1-1/2" Phillips pan machine screws (H) through RPM holes and into projector mounting plate. (See Figure 16)

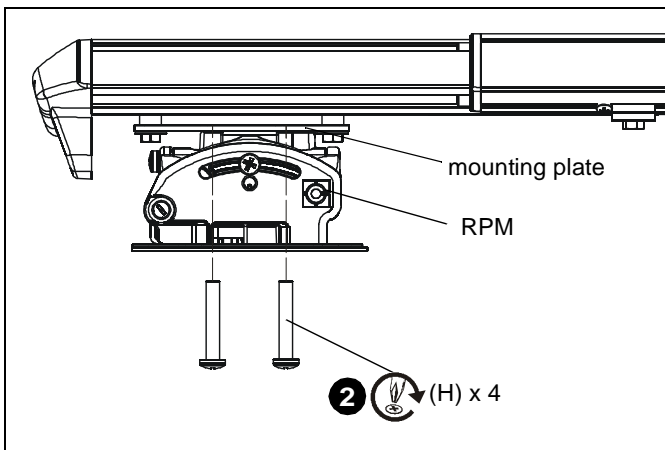

Figure 16

3. Install interface and projector to RPM according to RPM installation instructions.

RSM (not evaluated and tested by Underwriters Laboratories®) Installation

1. Line up mounting holes on RSM mount with corresponding holes on projector mounting plate. (See Figure 15)
2. Install four #10-24 x 1-3/8" Phillips pan machine screws (J) through RSM holes and into projector mounting plate. (See Figure 17)

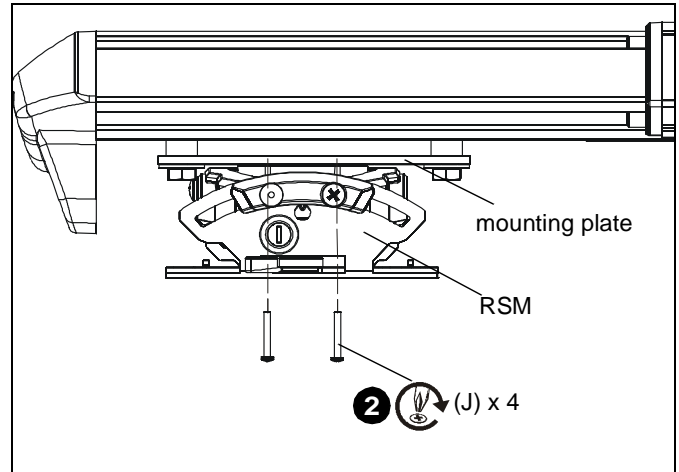

Figure 17

3. Install interface and projector to RSM according to RSM installation instructions.

RPA Installation

1. Line up mounting holes on RPA mount with corresponding holes on projector mounting plate. (See Figure 15)
2. Install four 1/4-20 x 3/8" Phillips pan machine screws (G) through RPA holes and into projector mounting plate. (See Figure 18)

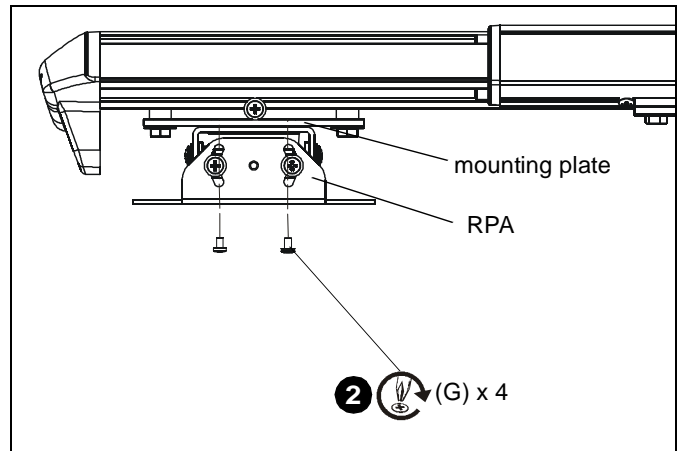

Figure 18

3. Install interface and projector to RPA according to RPA installation instructions.

RSA (not evaluated and tested by Underwriters Laboratories®) Installation

1. Line up mounting holes on RSA mount with corresponding holes on projector mounting plate. (See Figure 15)
2. Install four #10-24 x 3/8" Phillips pan machine screws (S) through RSA holes and into projector mounting plate. (See Figure 19)

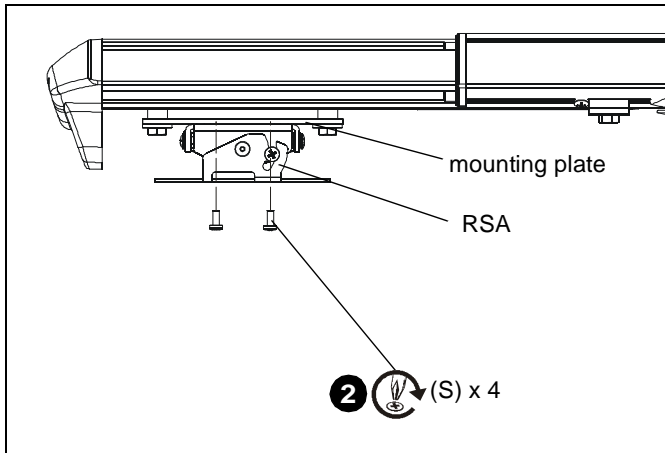

Figure 19

3. Install interface and projector to RSA according to RSA installation instructions.

Cable Management (Optional)

1. Remove two screws #8-32 x 1/2" Phillips pan machine screws (F) to release mount cover. (See Figure 20)
2. Slide mount cover away from wall mount. (See Figure 20)

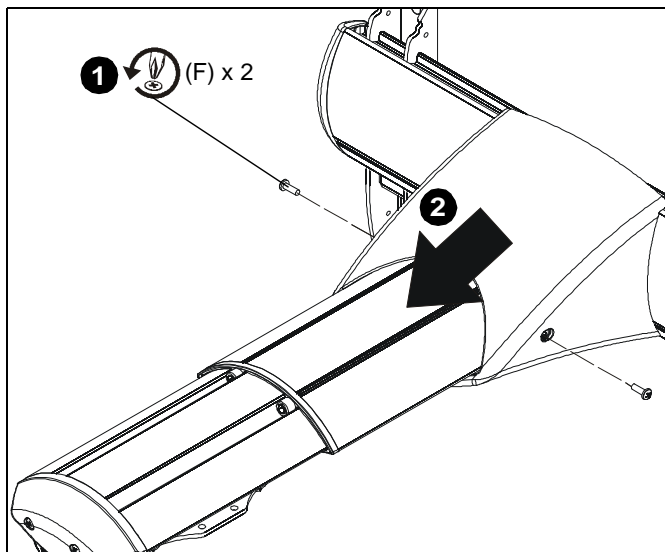

Figure 20

NOTE: In most cases, cable management covers will NOT need to be removed in order to route cables from projector to the wall mount. But for some thick cables, removing the covers may be necessary.

3. Remove cable management covers (if necessary) from short throw projector arm. (See Figure 21)

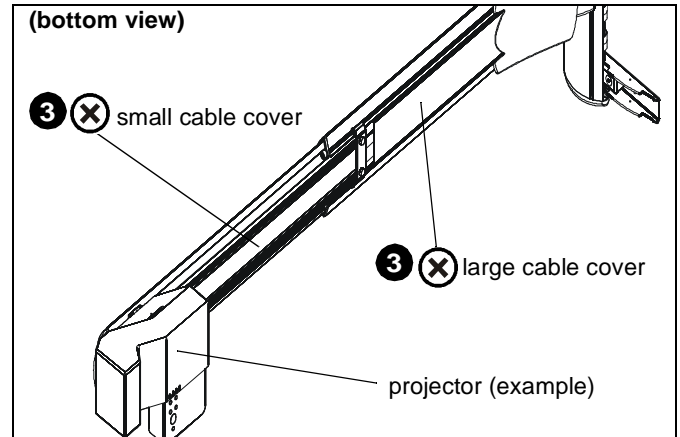

Figure 21

NOTE: Cables may be routed from below and up wall bracket channel, or from above and down behind and into wall mount.

• **Routing Cables from Below (Steps 4 and 5)**

4. Open cable clips along bottom edge of wall bracket cross bracket (See Figure 22)

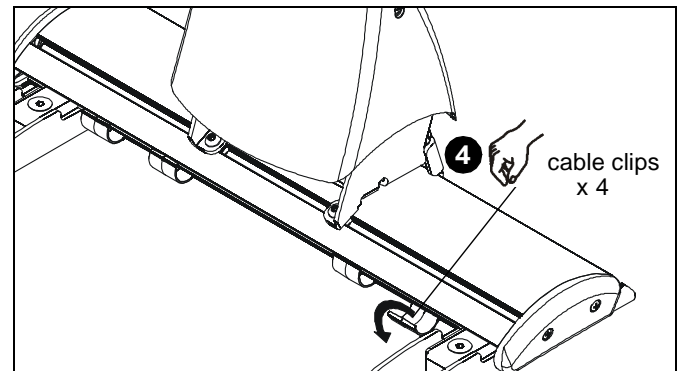

Figure 22

5. Thread cable up wall bracket channel and into opened cable clips. (See Figure 23) **Proceed to Step 7.**

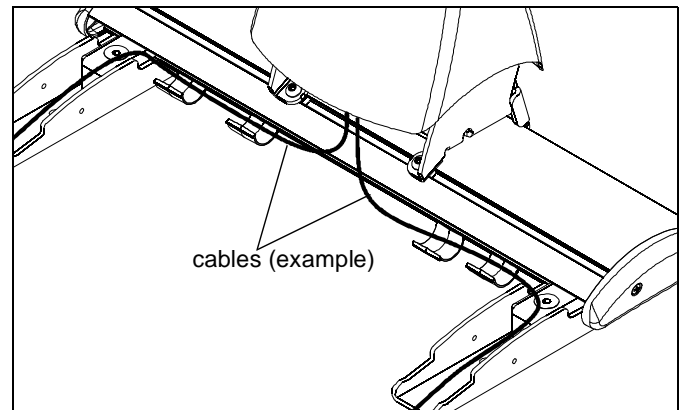

Figure 23

- **Routing Cables from Above (Step 6)**

6. Thread cables down through a surface mount cable accessory (not included), then behind and into the wall bracket. (See Figure 24) **Proceed to Step 7**
7. Route cables through cover mount, projector arm tunnel and into projector. (See Figure 25)

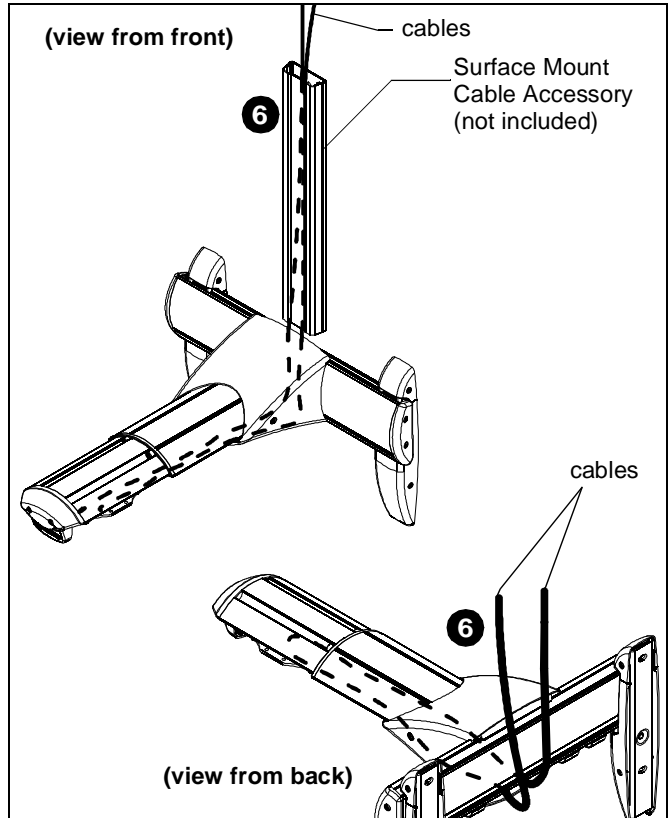

Figure 24

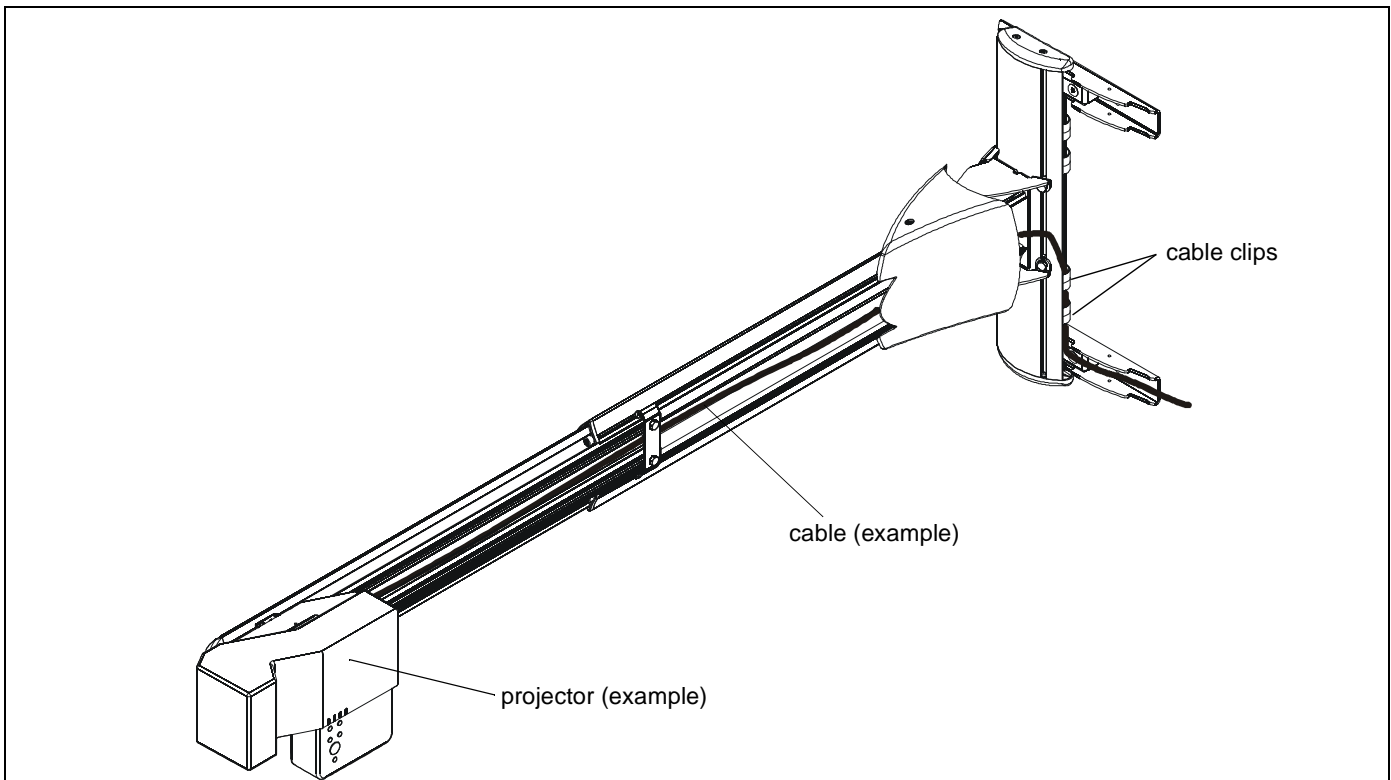

Figure 25

8. (Optional) Cables can be tied to inside of projector's front cover using cable ties (not included). Route cables near front cover and wrap cable tie through slots on front cover and around cables. (See Figure 26)

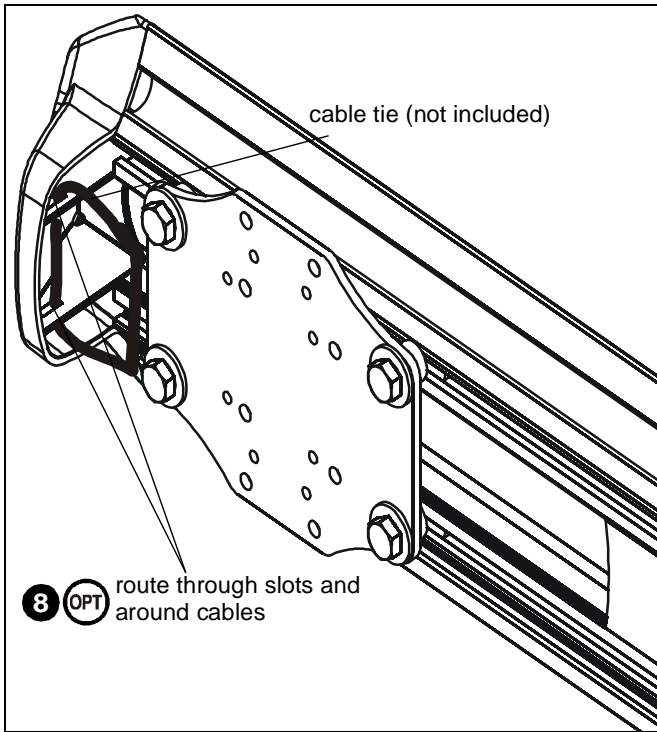

Figure 26

9. Replace removed cable management covers (if necessary). Insert one side of cover into groove and press down firmly on the cover on the other side until it snaps into the other groove. (See Figure 27)

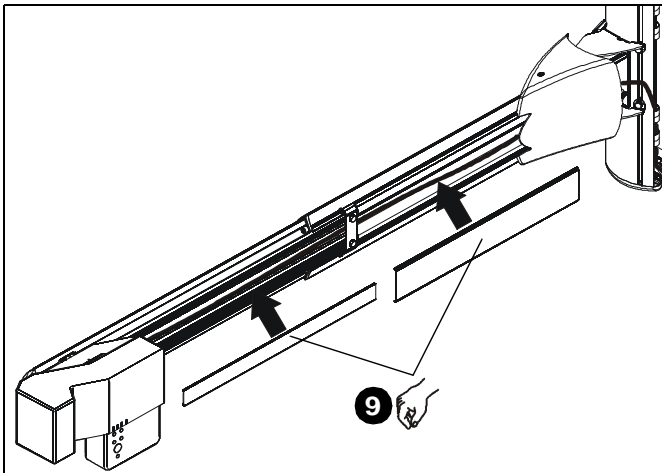

Figure 27

10. Slide outer cover of mount (A) back against mounting bracket. (See Figure 28)

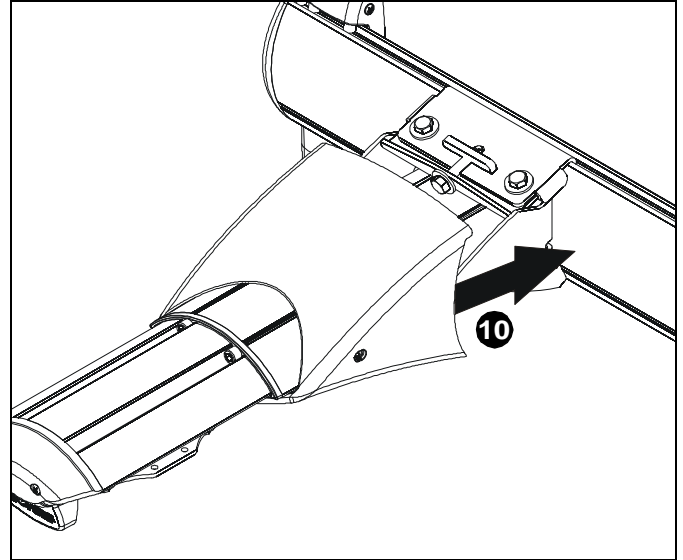

Figure 28

11. Reinstall two #8-32 x 1/2" Phillips pan machine screws (F) through holes on sides of outer cover. (See Figure 29)

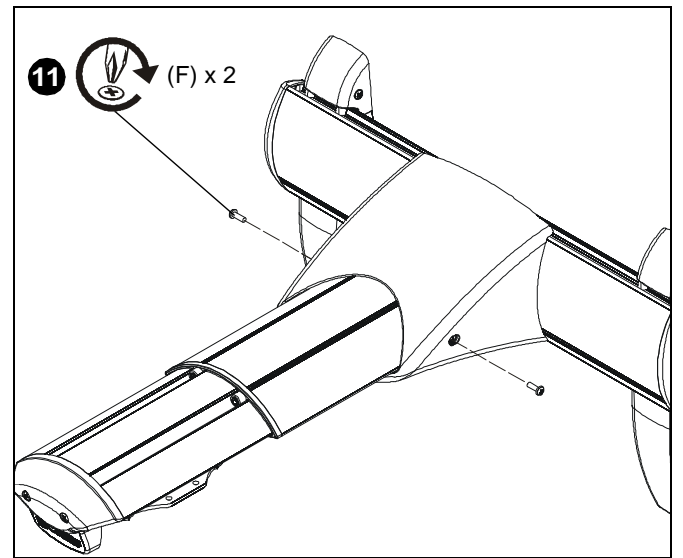

Figure 29

Installation of Wall Bracket Covers

NOTE: If security screws are going to be used, use the security screws (V) to install wall bracket covers. See Security Screw Installation section for details.

1. Place wall bracket top covers (C) over top of each wall bracket arm. (See Figure 30)

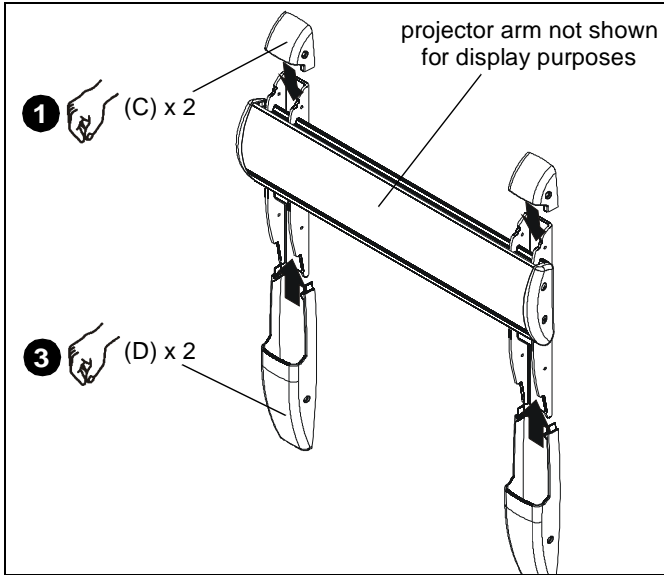

Figure 30

2. Secure wall bracket top covers (C) to wall bracket arms by installing four #8-32 x 1/2" Phillips pan machine screws (F) through holes in covers and wall bracket. (See Figure 31)
3. Place wall bracket bottom covers (D) over bottom of each wall bracket arm. (See Figure 30)
4. Secure wall bracket bottom covers (D) to wall bracket arms by installing four #8-32 x 1/2" Phillips pan machine screws (F) through holes in covers and wall bracket. (See Figure 31)

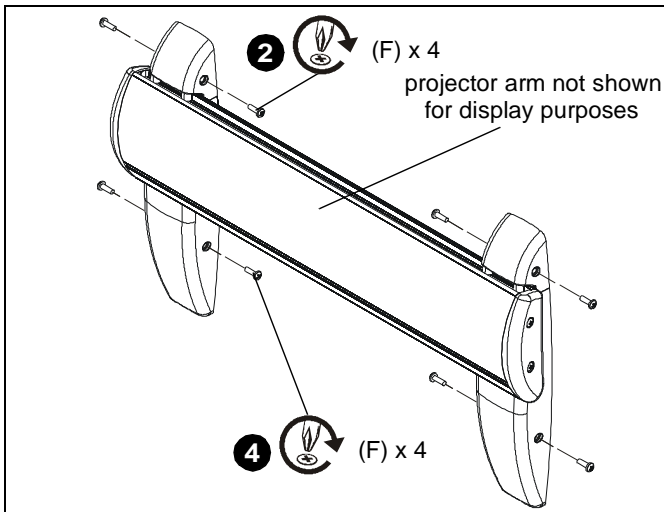

Figure 31

Adjustments

Bracket Width Adjustment

1. Loosen two flat head cap screws on wall bracket. (See Figure 32)
2. Slide wall brackets to corresponding width of studs. (See Figure 32)
3. Tighten two flat head cap screws on wall bracket. (See Figure 32)

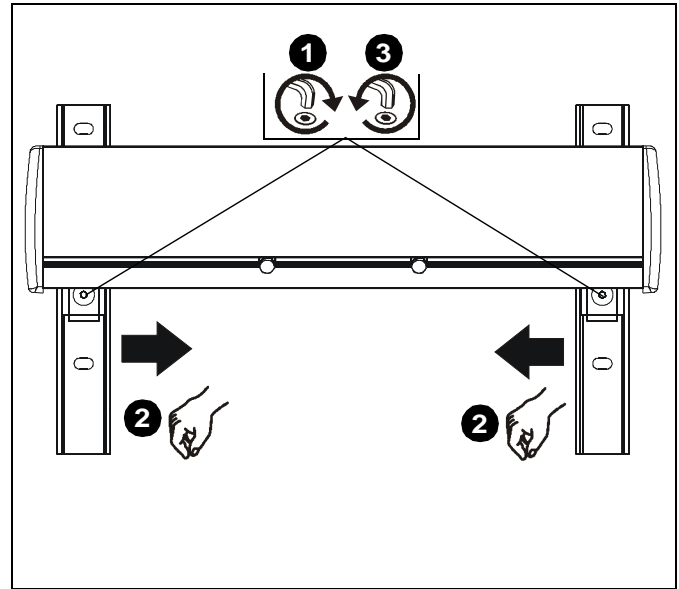

Figure 32

Pitch Adjustment

1. Remove two #8-32 x 1/2" Phillips pan machine screws (F) to free outer cover from mounting bracket. (See Figure 33)

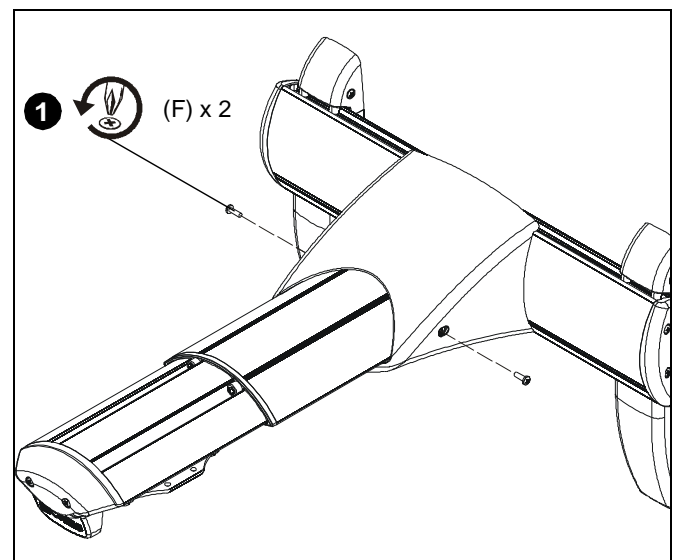

Figure 33

2. Slide outer cover of mount (A) away from mounting bracket to expose pitch adjustment screw. (See Figure 34)

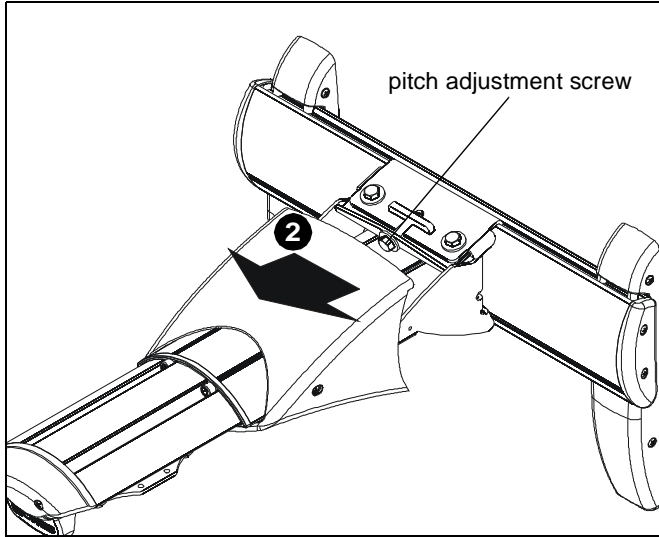

Figure 34

- Loosen two 1/4-20 x 5/8" hex head cap screws (E) on underside of mounting bracket. (See Figure 35)

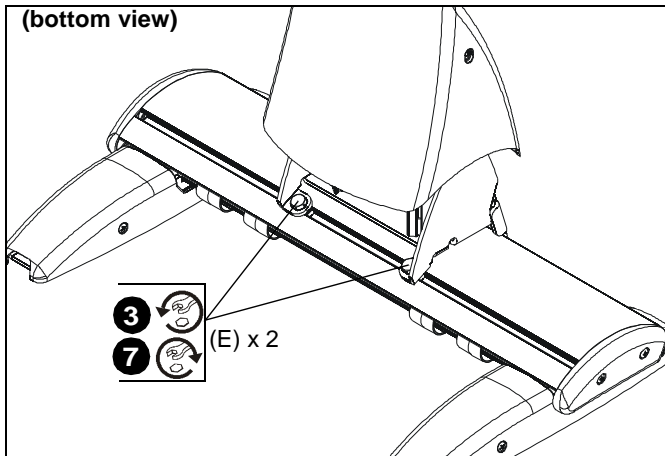

Figure 35

- Loosen two bolts on either side of pitch adjustment screw. (See Figure 36)
- Adjust pitch adjustment screw until mount is at desired pitch level. Turn clockwise to raise mounting level or turn counterclockwise to lower mounting level. (See Figure 36)
- Tighten two bolts on either side of pitch adjustment screw. (See Figure 36)
- Tighten two 1/4-20 x 5/8" screws (E) on underside of mounting bracket. (See Figure 36)

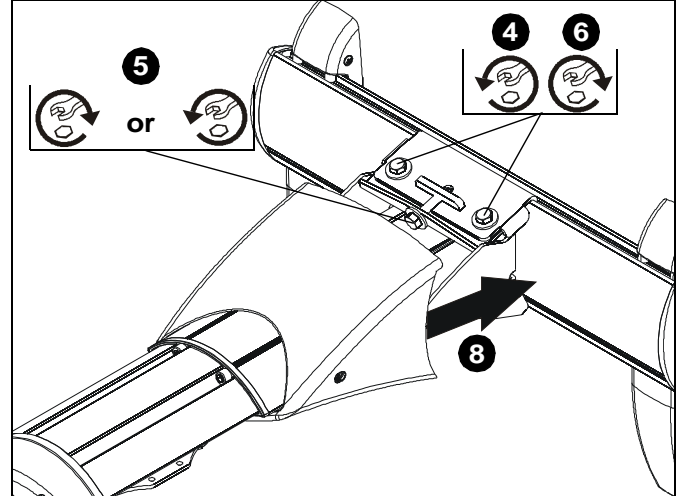

Figure 36

- Slide outer cover of mount (A) back against mounting bracket. (See Figure 36)
- Reinstall two #8-32 x 1/2" Phillips pan machine screws (F) through holes on sides of outer cover. (See Figure 37)

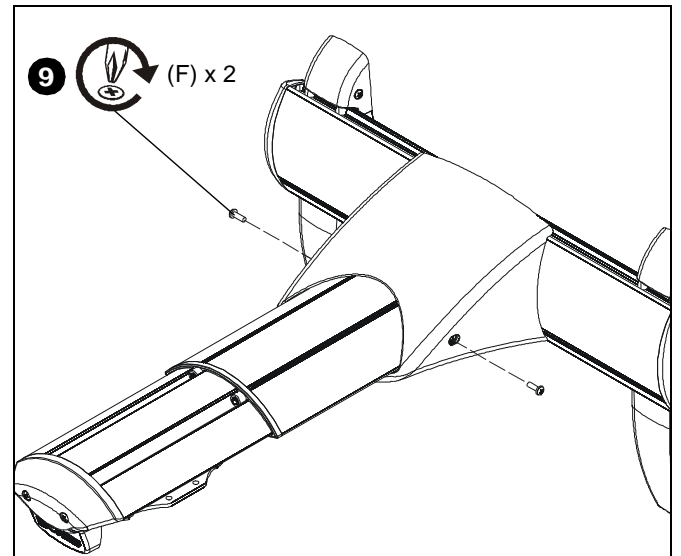

Figure 37

Extension Adjustment

- Loosen two bolts holding stop bracket in place on underside of short throw projector mount. (See Figure 38)
- Adjust mount to desired extension length. (See Figure 37)
- Tighten two bolts holding stop bracket to secure mount in desired position. (See Figure 38)

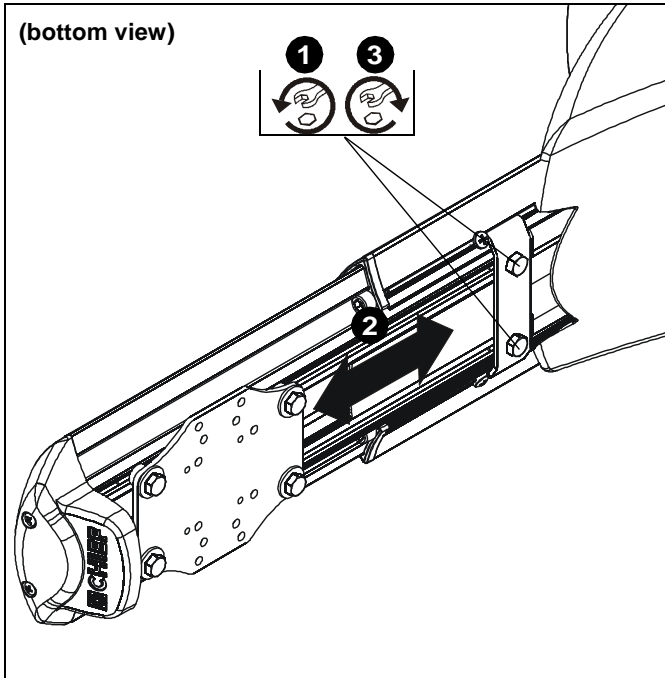

Figure 38

Lateral Shift Adjustment

1. Remove two #8-32 x 1/2" Phillips pan machine screws (F) to free outer cover from mounting bracket. (See Figure 39)

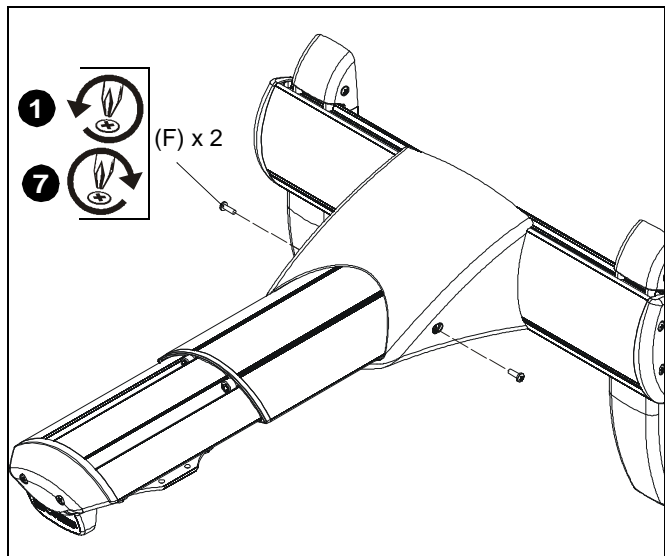

Figure 39

2. Slide outer cover of mount (A) away from mounting bracket. (See Figure 40)

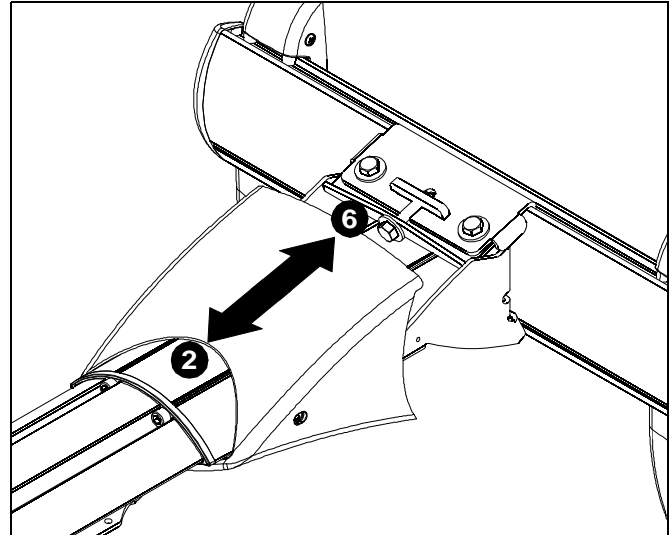

Figure 40

3. Loosen two 1/4-20 x 5/8" hex head cap screws (E) on underside of mounting bracket. (See Figure 41)
4. Adjust projector arm laterally to desired position. (See Figure 41)
5. Tighten two 1/4-20 x 5/8" hex head cap screws loosened in Step 3. (See Figure 41)
6. Slide outer cover of mount (A) back against mounting bracket. (See Figure 40)
7. Replace two #8-32 x 1/2" Phillips pan machine screws removed in Step 1. (See Figure 39)

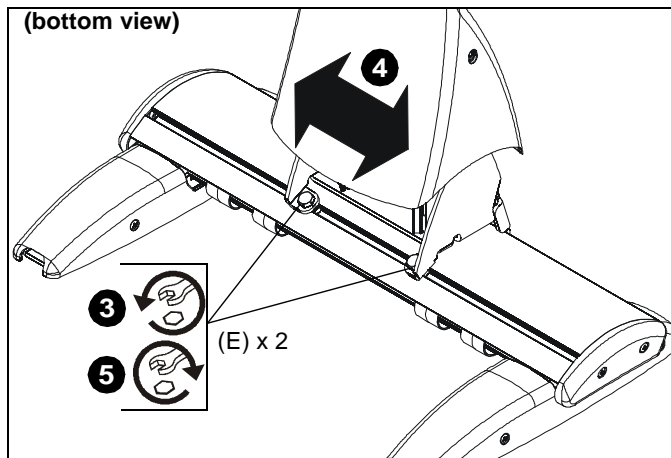

Figure 41

Security Screw Installation (Optional)

1. Remove eight #8-32 x 1/2" Phillips pan machine screws (F) from wall bracket covers. (See Figure 42)

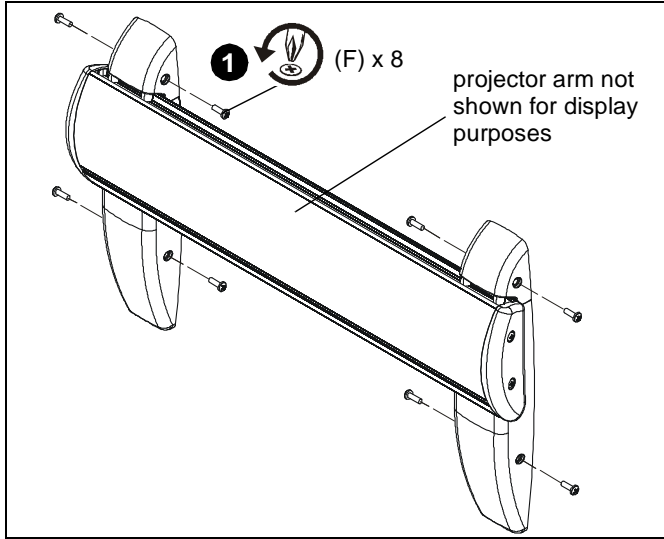

Figure 42

2. Install eight #8-32 x 1/2" button head security screws (V) into holes in wall bracket covers. (See Figure 43)

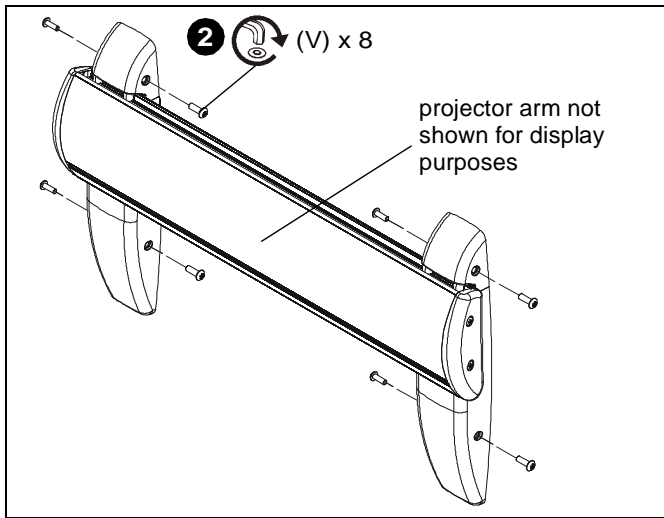

Figure 43

3. Remove two #8-32 x 1/2" Phillips pan machine screws (F) holding mount cover on projector arm. (See Figure 44)
4. Install two #8-32 x 1/2" button head security screws (V) into holes on mount cover. (See Figure 44)

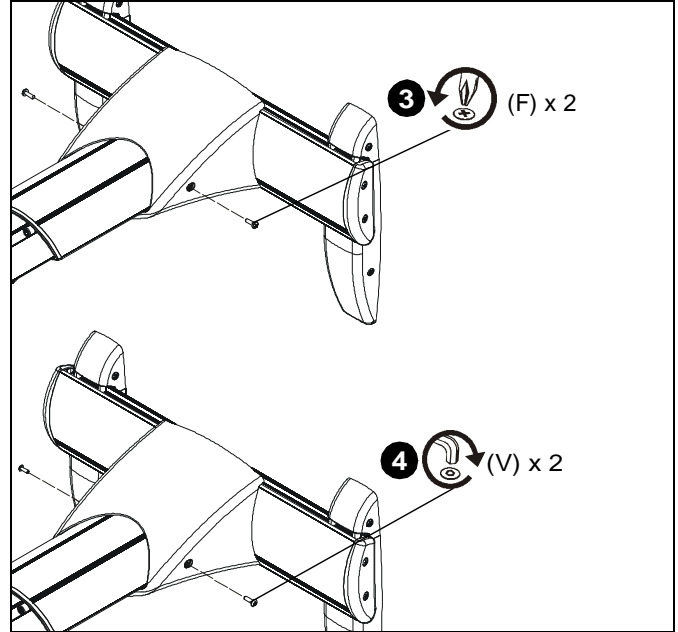

Figure 44

5. Remove two bolts holding stop bracket in place on underside of short throw projector mount. (See Figure 45)

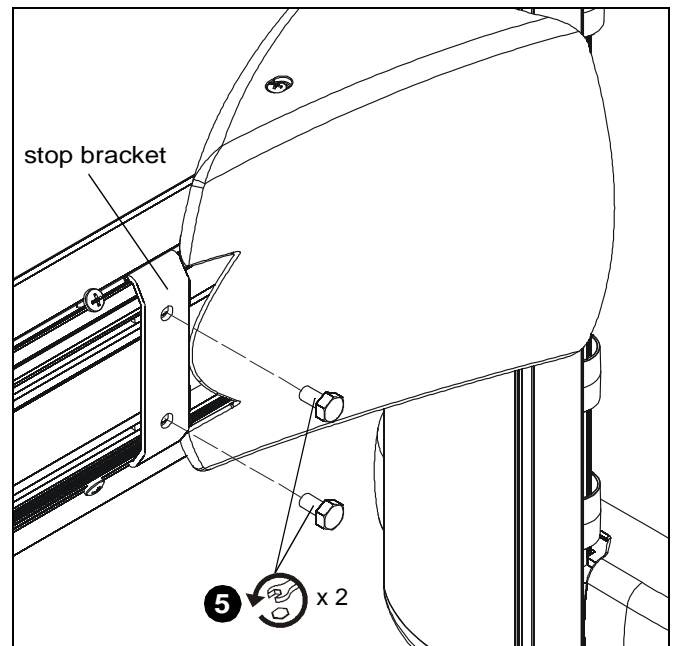

Figure 45

6. Install two 1/4-20 x 1/2" button head security screws (T) through holes in stop bracket and into holes in sliding nuts. (See Figure 46)

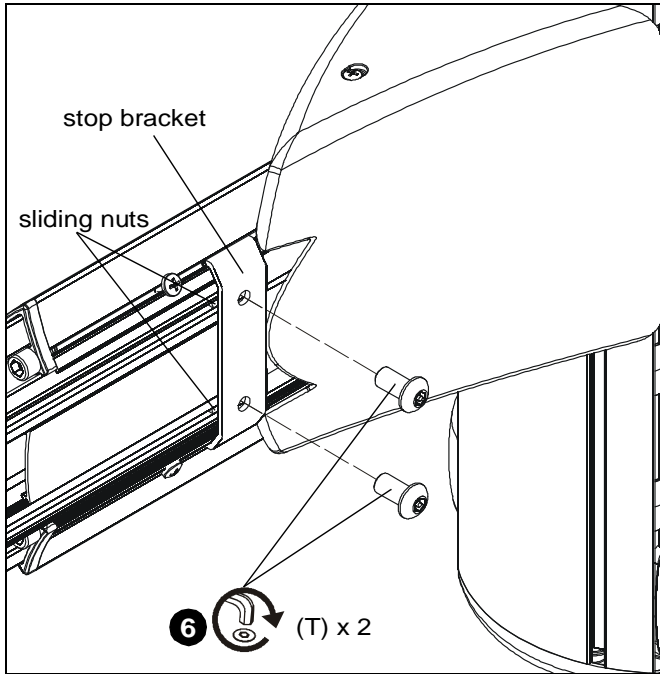

Figure 46

7. (Optional) Remove projector from short throw projector mount according to projector interface instructions.

NOTE: For most projectors, it will be necessary to remove projector prior to install four security screws to projector bracket. For ease of installation, it is recommended to remove projector prior to performing the following steps.

8. Remove one of four bolts from adapter plate. (See Figure 47)

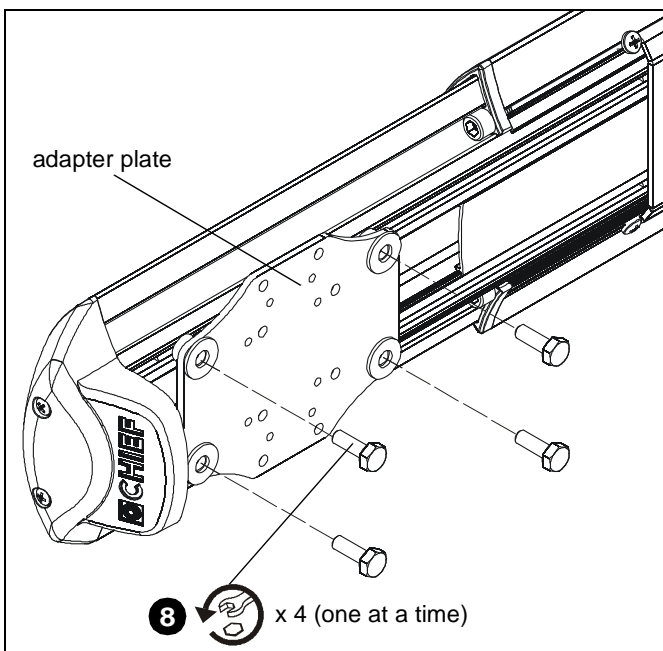

Figure 47

9. Install one 1/4-20 x 3/4" button head security screw (U) into hole vacated by removing bolt in Step 8 and into plastic spacer. (See Figure 48)
10. Repeat Steps 8-9 for remaining three bolts one bolt at a time.



WARNING: It is important to replace adapter plate bolts ONE AT A TIME or adapter plate could fall from mount during installation!

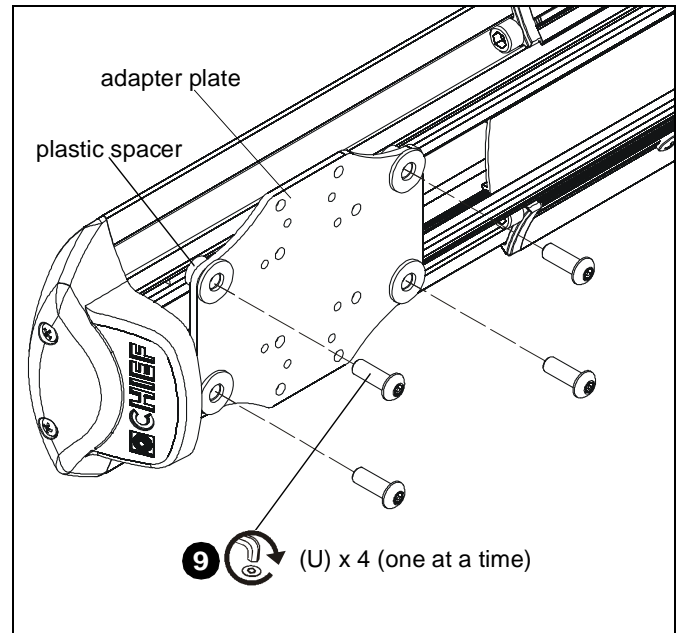

Figure 48

11. Reinstall projector according to interface instructions.



Our Mounts. **Your Vision.**

Chief Manufacturing, a products division
of Milestone AV Technologies

8802-002037 Rev04
©2010 Milestone AV Technologies, a
Duchossois Group Company
www.chiefmfg.com
01/10

USA/International	A 8401 Eagle Creek Parkway, Savage, MN 55378 P 800.582.6480 / 952.894.6280 F 877.894.6918 / 952.894.6918
Europe	A Fellenoord 130 5611 ZB EINDHOVEN, The Netherlands P +31 (0)40 2668620 F +31 (0)40 2668615
Asia Pacific	A Office No. 1 on 12/F, Shatin Galleria 18-24 Shan Mei Street Fotan, Shatin, Hong Kong P 852 2145 4099 F 852 2145 4477

