INSTALLATION INSTRUCTIONS

SHELF ACCESSORY

PAS-100

The shelf accessory is designed to add storage capability to the Chief PPC series carts.

Unpack and check contents:

(1) ACRYLIC SHELF ASSEMBLY

(1) SHELF BRACKET-LEFT

(1) SHELF BRACKET-RIGHT

(4) 1/4-20 BUTTON HEAD SCREWS

(4) 10-24 NYLOCK NUTS

(4) #10 WASHER

(1) 5/32" HEX KEY

INSTALLATION INSTRUCTIONS

1. Loosely attach shelf brackets to upright posts (see Figure 1) using four 1/4-20 button head cap screws. Do not fully tighten the bolts.
2. Place shelf in desired location and loosely secure shelf using the #10 washers and #10 Nylock nuts (see Figure 2).
3. Tighten screws securing shelf bracket.
4. Tighten nuts securing shelf.

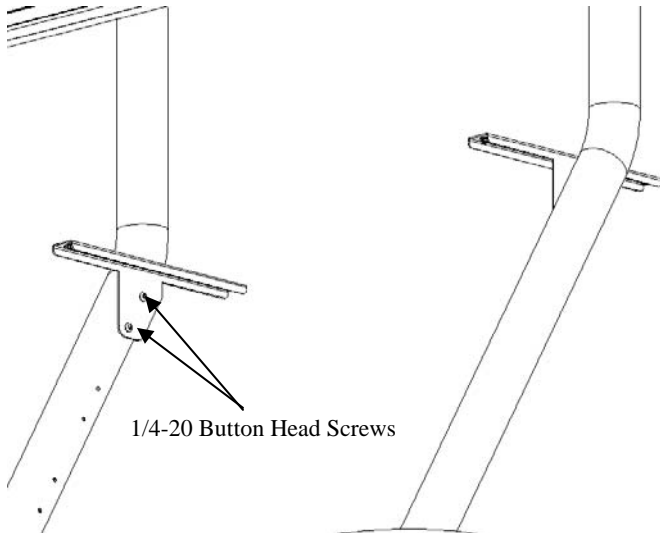

Figure 1

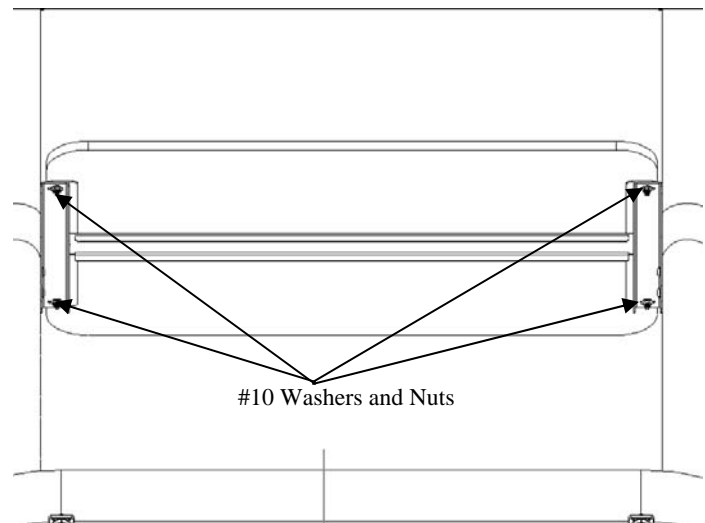

Figure 2



CHIEF MANUFACTURING INC.
1-800-582-6480 952-894-6280 FAX 952-894-6918
12800 HIGHWAY 13 SOUTH, SUITE 500
SAVAGE, MINNESOTA 55378 USA

8809-000013
2003 Chief Manufacturing
www.chiefmfg.com
04/04