

# INSTALLATION INSTRUCTIONS

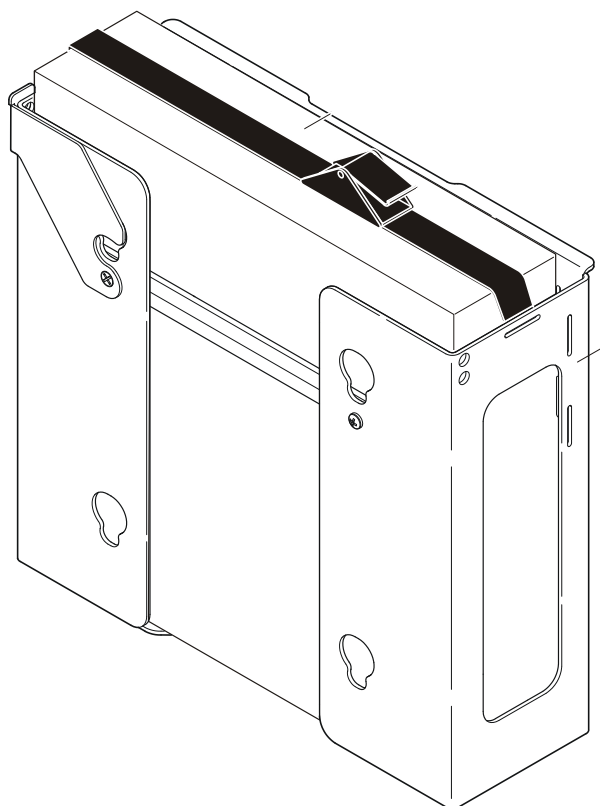

---

**CPU Adapter**

---

## DISCLAIMER

CSAV, Inc., and its affiliated corporations and subsidiaries (collectively, "CSAV"), intend to make this manual accurate and complete. However, CSAV makes no claim that the information contained herein covers all details, conditions or variations, nor does it provide for every possible contingency in connection with the installation or use of this product. The information contained in this document is subject to change without notice or obligation of any kind. CSAV makes no representation of warranty, expressed or implied, regarding the information contained herein. CSAV assumes no responsibility for accuracy, completeness or sufficiency of the information contained in this document.



### IMPORTANT WARNINGS AND CAUTIONS!



**WARNING:** A WARNING alerts you to the possibility of serious injury or death if you do not follow the instructions.



**CAUTION:** A CAUTION alerts you to the possibility of damage or destruction of equipment if you do not follow the corresponding instructions.



**WARNING:** Failure to read, thoroughly understand, and follow all instructions can result in serious personal injury, damage to equipment, or voiding of factory warranty! It is the installer's responsibility to make sure all components are properly assembled and installed using the instructions provided.



**WARNING:** Failure to provide adequate structural strength for this component can result in serious personal injury or damage to equipment! It is the installer's responsibility to make sure the structure to which this component is attached can support five times the combined weight of all equipment. Reinforce the structure as required before installing the component.



**WARNING:** Exceeding weight capacity can result in serious personal injury or damage to equipment! It is the installer's responsibility to make sure the combined weight of all components does not exceed the maximum allowable weight of the mount to which this accessory is being installed.

**DIMENSIONS**

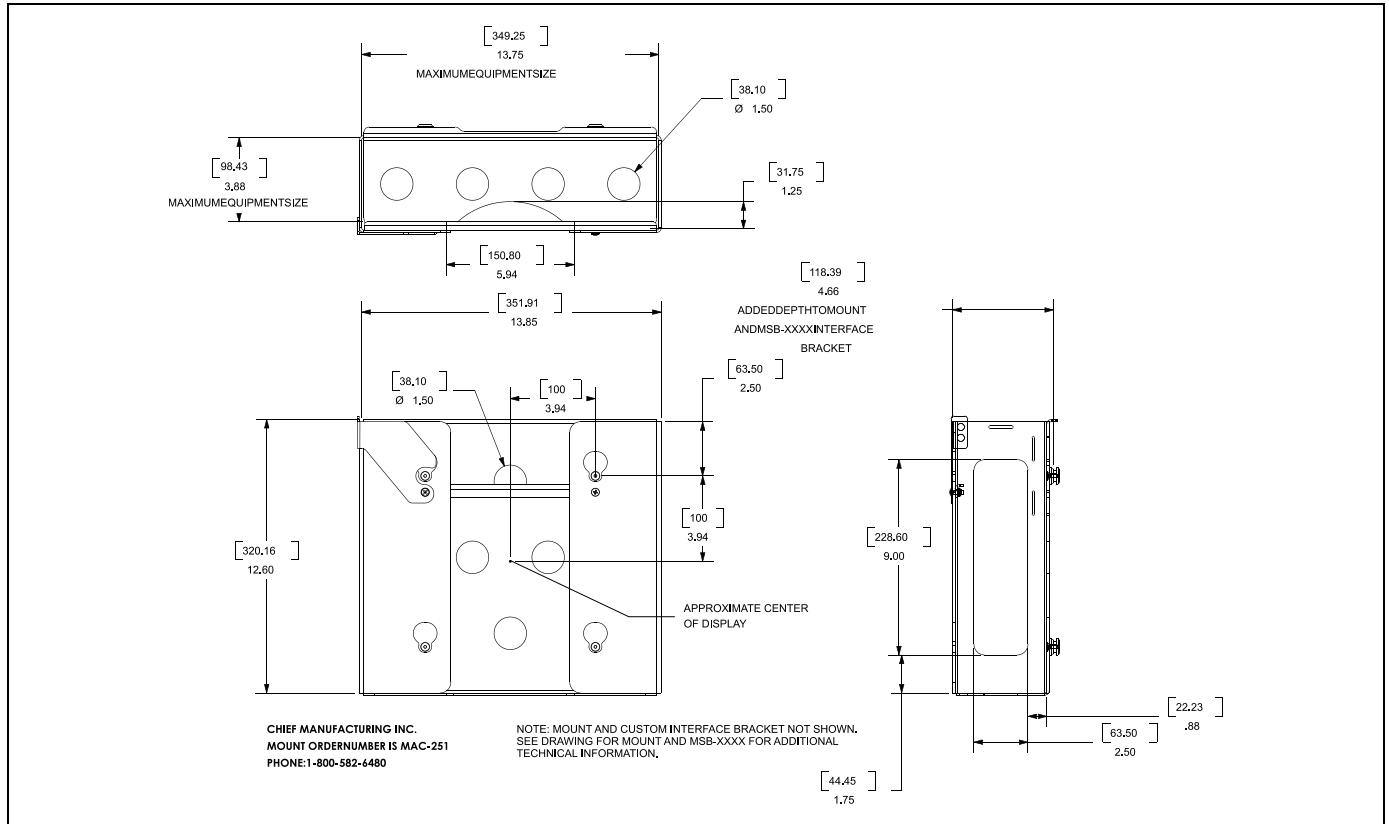

**LEGEND**

	<b>Tighten Fastener</b>
	Apretar elemento de fijación
	Befestigungsteil festziehen
	Apertar fixador
	Serrare il fissaggio
	Bevestiging vastdraaien
	Serrez les fixations

	<b>Security Wrench</b>
	Llave de seguridad
	Sicherheitsschlüssel
	Chave de segurança
	Chiave di sicurezza
	Veiligheidssleutel
	Clé de sécurité

	<b>Loosen Fastener</b>
	Aflojar elemento de fijación
	Befestigungsteil lösen
	Desapertar fixador
	Allentare il fissaggio
	Bevestiging losdraaien
	Desserrez les fixations

	<b>By Hand</b>
	A mano
	Von Hand
	Com a mão
	A mano
	Met de hand
	À la main

### TOOLS REQUIRED FOR INSTALLATION

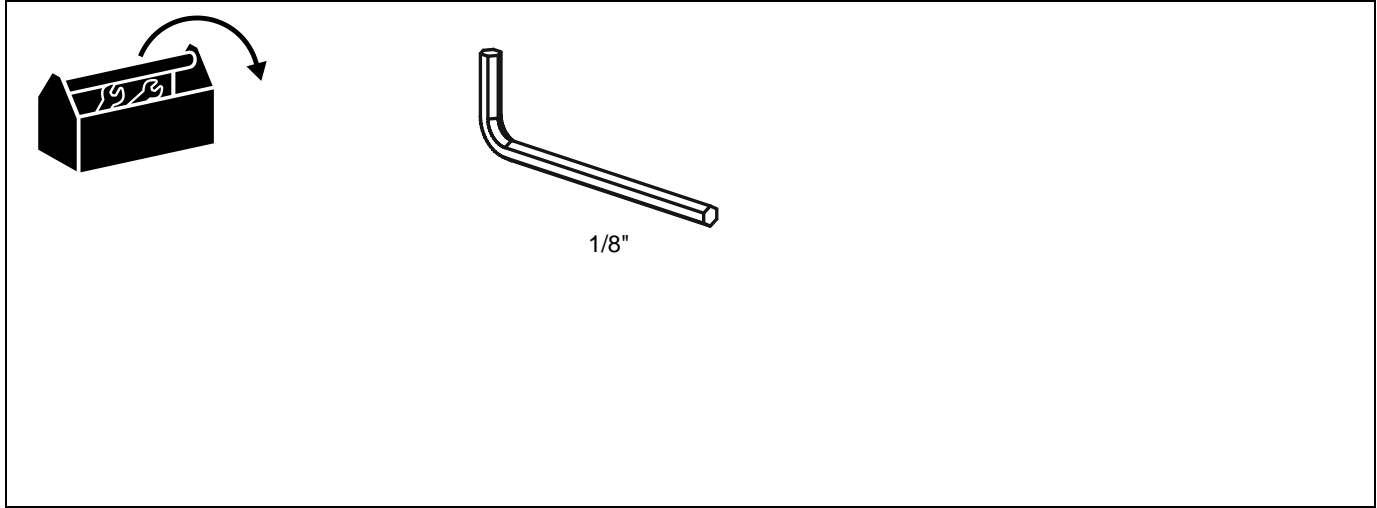

### PARTS

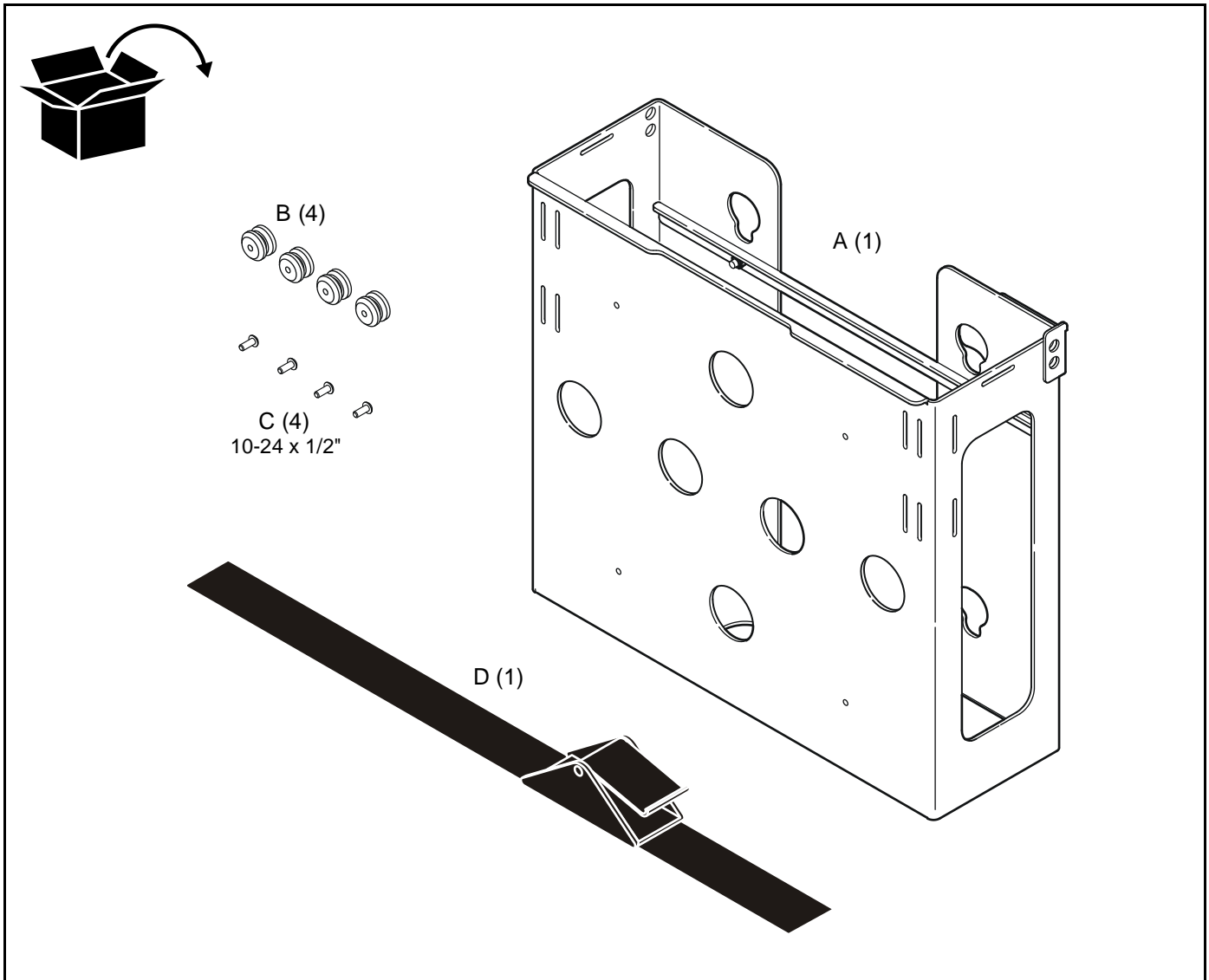

## MOUNT ASSEMBLY

### Assemble Mounting Buttons to CPU Holder

To install mounting buttons:



**WARNING:** IMPROPER INSTALLATION CAN LEAD TO CPU HOLDER FALLING! Mounting buttons must be securely fastened to device rack.

1. Install four mounting buttons (B) to CPU holder (A) using four 10-24 x 1/2" flat head cap screws (C), and a 1/8" hex wrench.

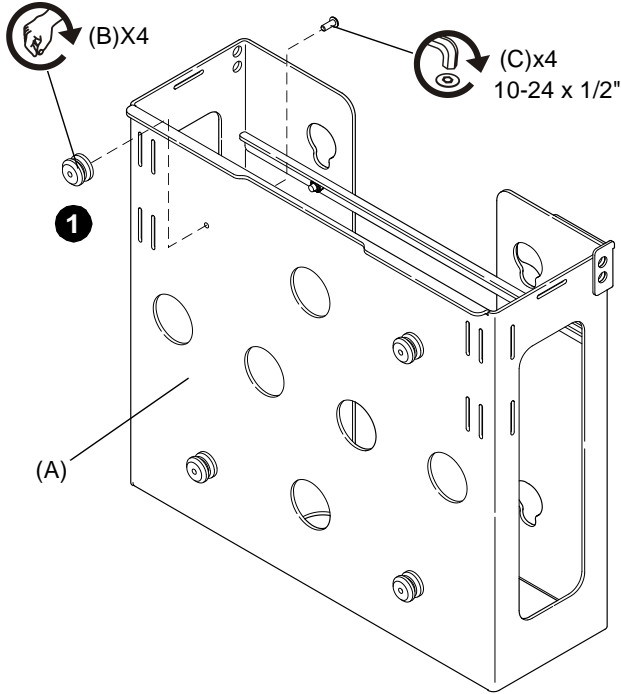

Figure 1

### Assemble CPU to CPU Holder

1. Place CPU into CPU Holder making certain connections on CPU are oriented with cable access opening in sides of CPU Holder.

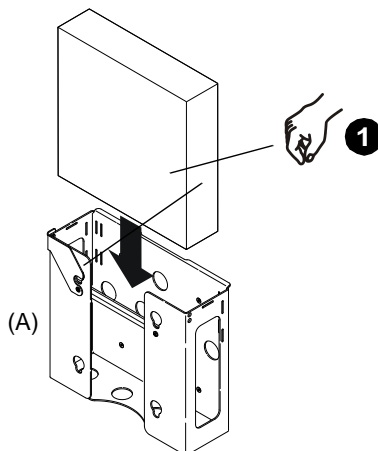

Figure 2

### Assemble Mounting Strap to CPU Holder

1. Install Strap as shown in figure 3 below and secure.

**NOTE:** Strap can also be installed so that it wraps around sides of CPU holder.

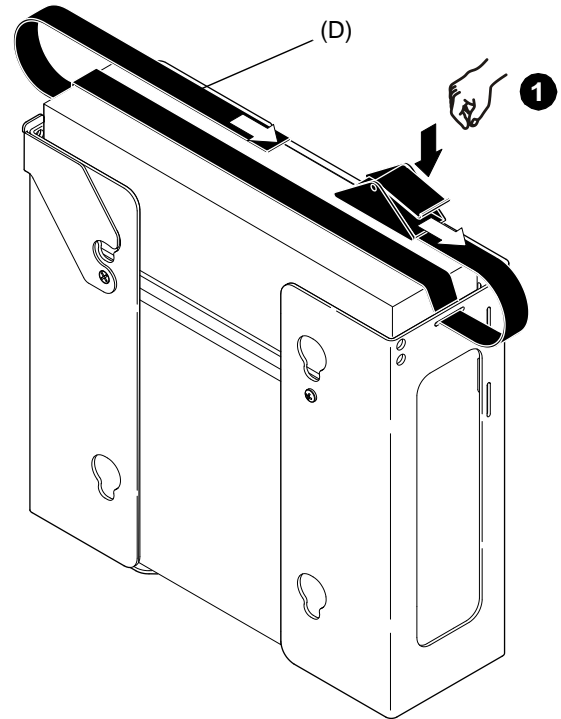

Figure 3

## INSTALLATION

### Install CPU Holder with CPU to Mount



**WARNING:** COMBINED WEIGHT OF CPU AND CPU HOLDER MAY WEIGHT IN EXCESS OF 40 LBS. ALWAYS use two people when lifting and follow proper lifting techniques when installing!

Install the CPU holder, with CPU, onto mount and route wires and cables following the instructions provided with the mount.



**WARNING:** IMPROPER INSTALLATION CAN LEAD TO CPU HOLDER FALLING! Make certain mounting buttons on CPU holder are fully engaged in teardrop holes in mount and latching flag on mount is fully closed before installing the display.

### Install Display



**WARNING:** DISPLAY MAY WEIGH IN EXCESS OF 40 LBS. ALWAYS use two people when lifting and follow proper lifting techniques when installing!

**IMPORTANT !** : The following procedure assumes that the proper interface bracket for display being mounted has already been installed on display. If no interface bracket is present on display, install bracket to display using instructions included with interface bracket before proceeding.

To install the display:

1. Make sure latching flag is in the UNLATCHED position (See Figure 4).

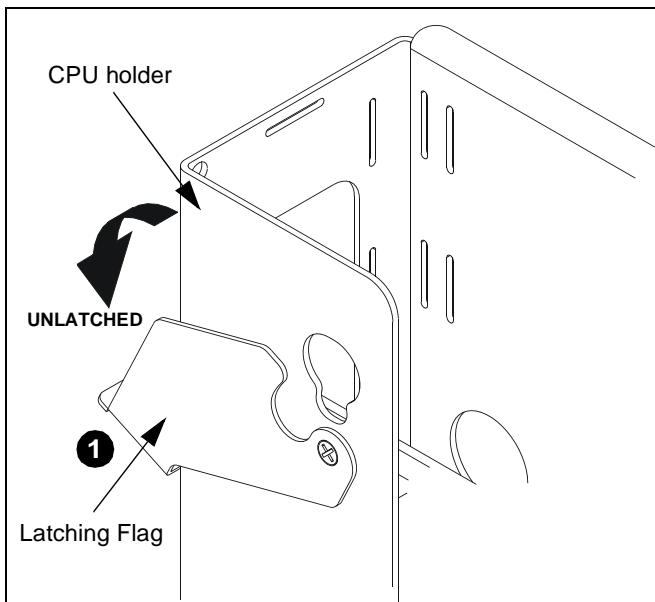

**Figure 4:**

2. While supporting each side of display, align four mounting buttons on display or interface bracket with four teardrop slots in CPU holder (See Figure 5).
3. Lower display firmly into place .

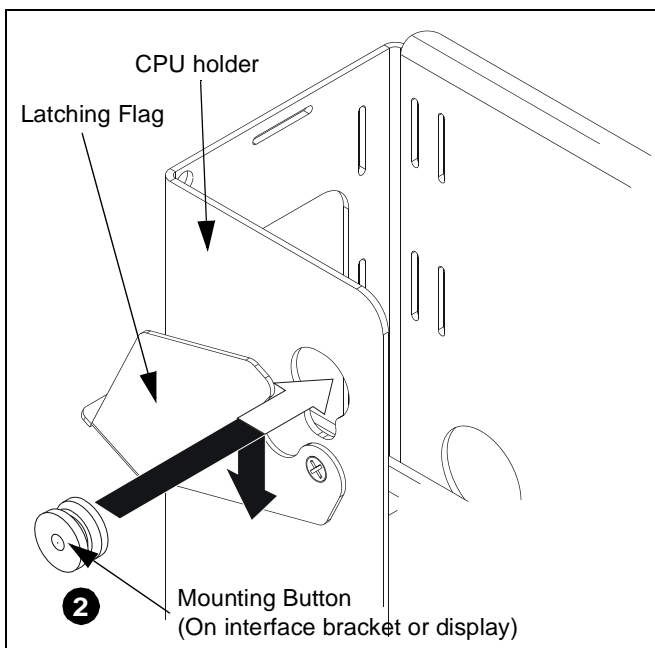

**Figure 5**



**CAUTION:** Latching flag must fully engage mounting button.

4. Secure display by rotating latching flag to the LATCHED position (See Figure 6). If latching flag does not fully engage, ensure mounting buttons are fully seated in teardrop slots.

**NOTE:** A hole is provided in the latching flag and CPU holder to accommodate insertion of a padlock or similar locking device.

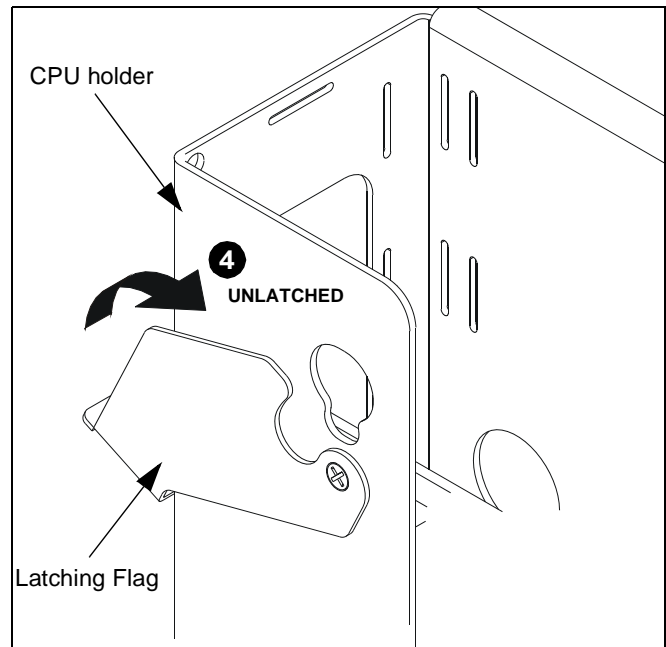

**Figure 6:**

5. Connect cables to display.





8804-000316  
©2006 Chief Manufacturing  
[www.chiefmfg.com](http://www.chiefmfg.com)  
06/06

<b>USA/International</b>	<b>A</b> 8401 Eagle Creek Parkway, Savage, MN 55378 <b>P</b> 800.582.6480 / 952.894.6280 <b>F</b> 877.894.6918 / 952.894.6918
<b>Europe</b>	<b>A</b> Fellenoord 130 5611 ZB EINDHOVEN, The Netherlands <b>P</b> 31 (0)20 5708923 <b>F</b> 31 (0)20 5708989
<b>Asia Pacific</b>	<b>A</b> Room 30I, Block D, Lily YinDu International Building LuoGang, BuJi Town, Shenzhen, CHINA. Post Code: 518112 深圳市布吉罗岗百合银都国际大厦D栋30I <b>P</b> +86-755-8996 9226 ; 8996 9236 ; 8996 9220 <b>F</b> +86-755-8996 9217