

INSTALLATION INSTRUCTIONS

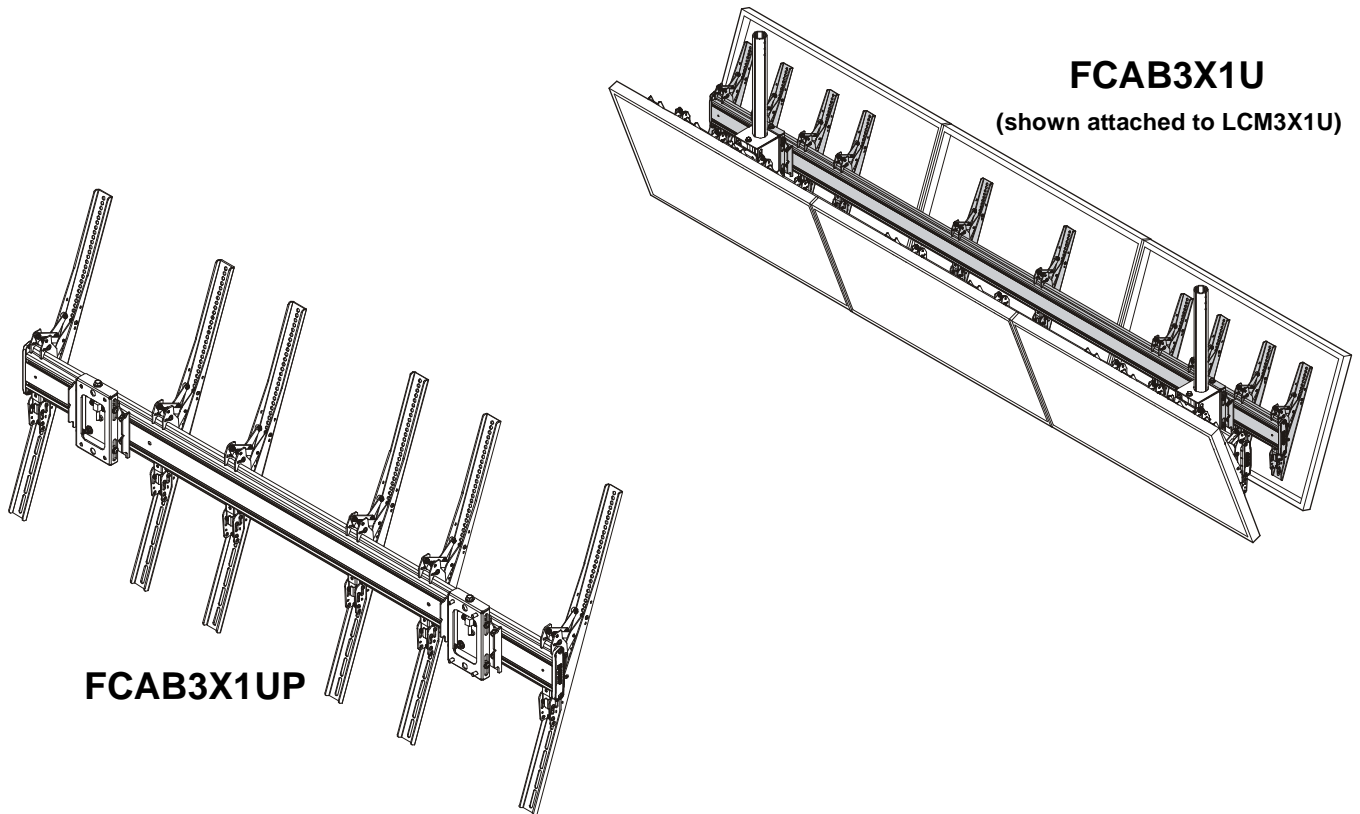

Menu Board Back Row Add-On Kits

DISCLAIMER

Milestone AV Technologies and its affiliated corporations and subsidiaries (collectively "Milestone"), intend to make this manual accurate and complete. However, Milestone makes no claim that the information contained herein covers all details, conditions or variations, nor does it provide for every possible contingency in connection with the installation or use of this product. The information contained in this document is subject to change without notice or obligation of any kind. Milestone makes no representation of warranty, expressed or implied, regarding the information contained herein. Milestone assumes no responsibility for accuracy, completeness or sufficiency of the information contained in this document.

Chief® is a registered trademark of Milestone AV Technologies. All rights reserved.

 **IMPORTANT SAFETY INSTRUCTIONS**

 **WARNING:** A WARNING alerts you to the possibility of serious injury or death if you do not follow the instructions.

 **CAUTION:** A CAUTION alerts you to the possibility of damage or destruction of equipment if you do not follow the corresponding instructions.

 **WARNING:** Failure to read, thoroughly understand, and follow all instructions can result in serious personal injury, damage to equipment, or voiding of factory warranty! It is the installer's responsibility to make sure all components are properly assembled and installed using the instructions provided.

 **WARNING:** Failure to provide adequate structural strength for this component can result in serious personal injury or damage to equipment! It is the installer's responsibility to make sure the structure to which this component is attached can support five times the combined weight of all equipment. Reinforce the structure as required before installing the component.



 **WARNING:** Exceeding the weight capacity can result in serious personal injury or damage to equipment! It is the installer's responsibility to make sure the combined weight of all components located within the mounting system of the LCB2X1U/LCB2X1UP models does not exceed maximum weights listed in Table 1.

Table 1: Weight Capacity

MODEL	Max Weight Allowed for EACH Display	Total Max Weight Capacity of Mounting System w/Accessory
FCAB3X1U	125 lbs (56.7 kg)	with LCM3X1U 750 lbs (340.2 kg)
FCAB3X1UP	125 lbs (56.7 kg)	with LCM3X1UP 750 lbs (340.2 kg)

 **WARNING:** Never operate this mounting system if it is damaged. Return the mounting system to a service center for examination and repair.

 **WARNING:** Do not use this product outdoors.

NOTE: The UL Listed FCAB add-on rows may be used with the following UL Listed models: FCAB3X1U may be used with LCM3X1U. FCAB3X1UP may be used with LCM3X1UP.

--SAVE THESE INSTRUCTIONS--

DIMENSIONS

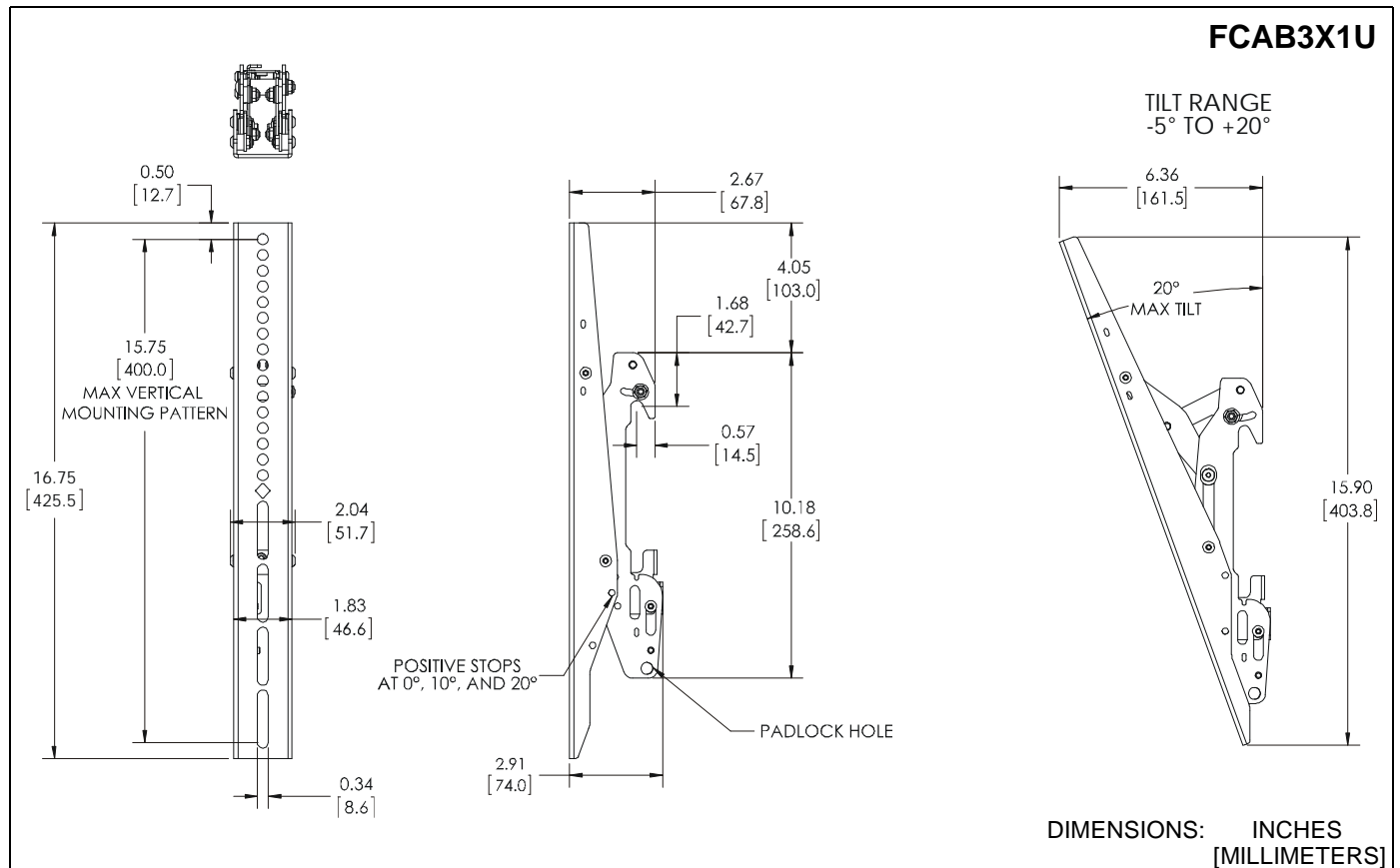
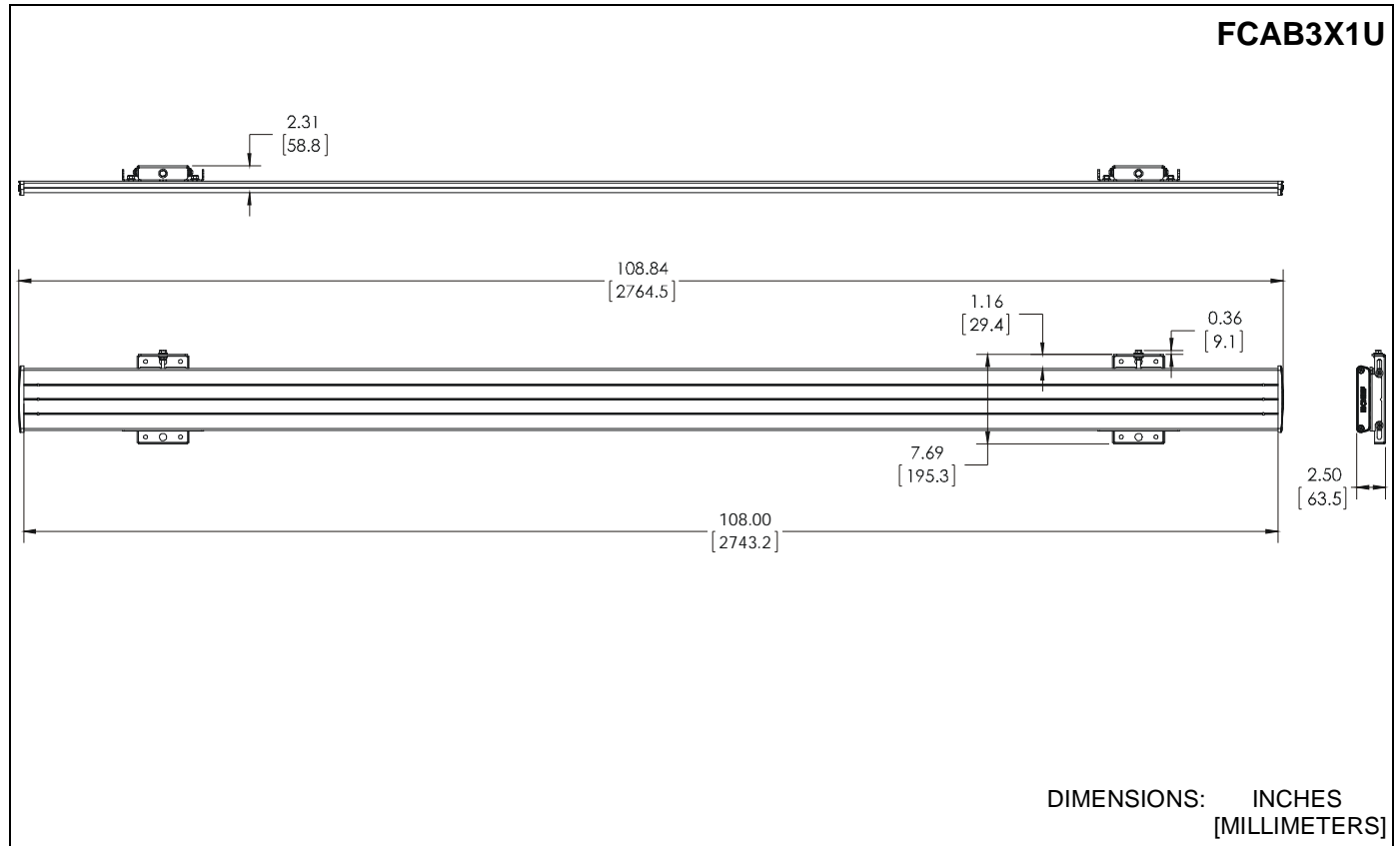

DIMENSIONS (cont'd)

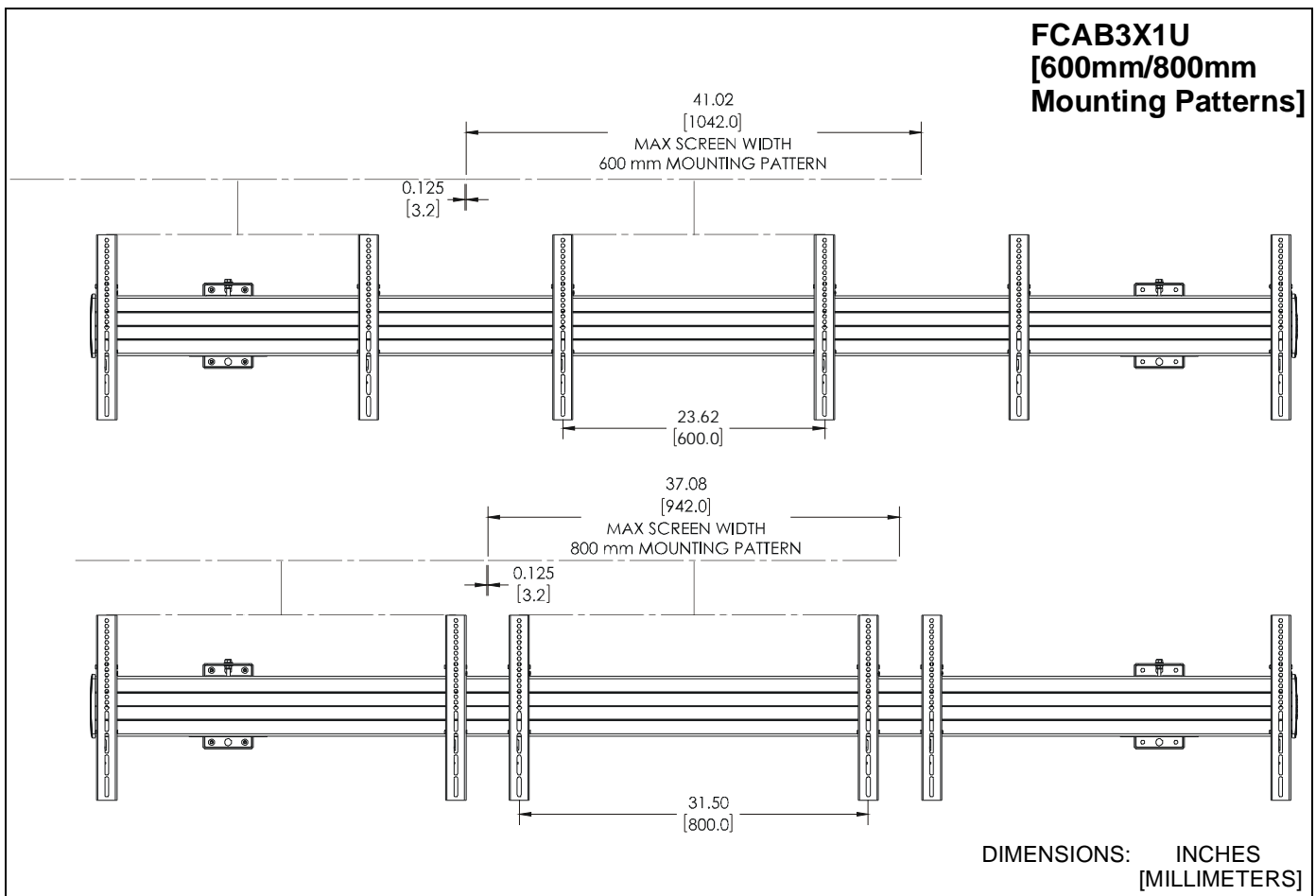
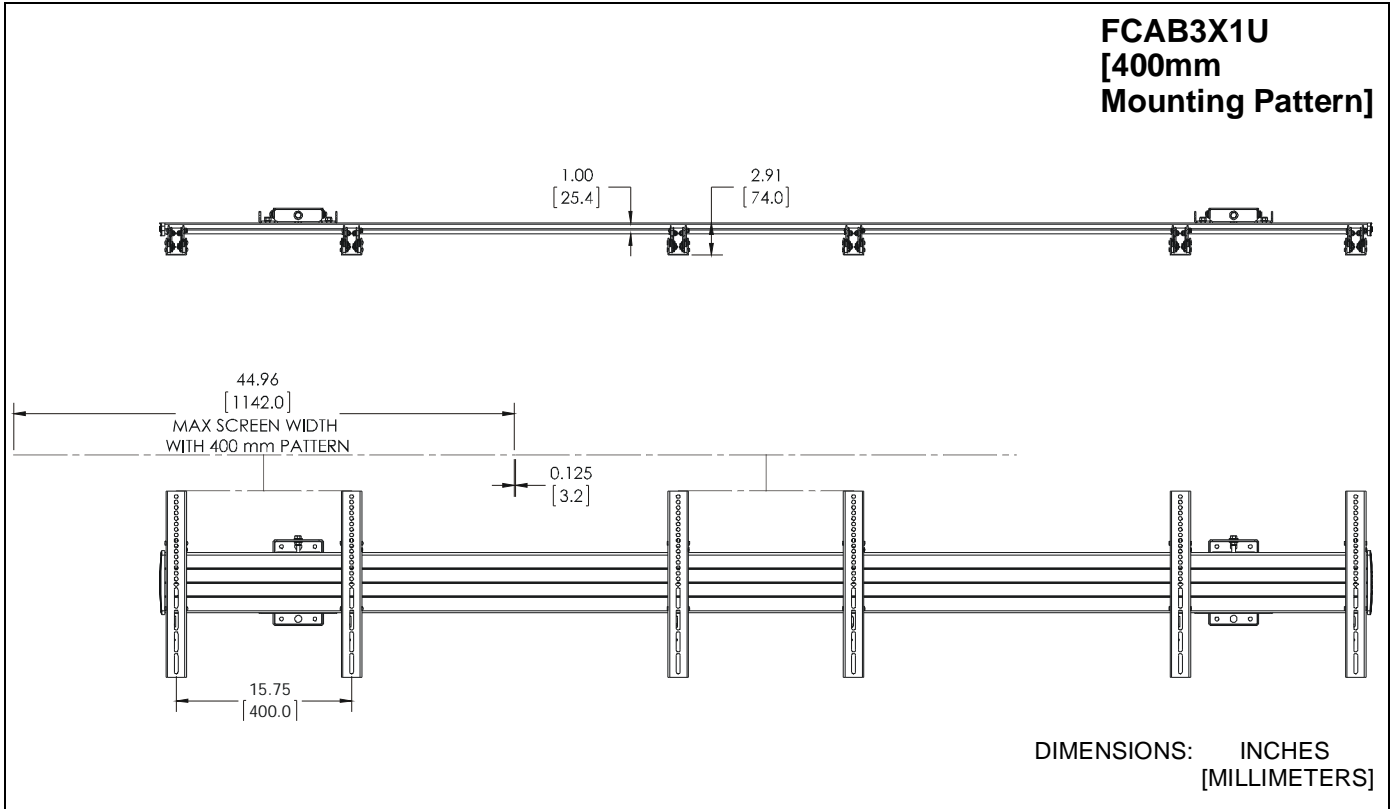

DIMENSIONS (cont'd)

FCAB3X1UP

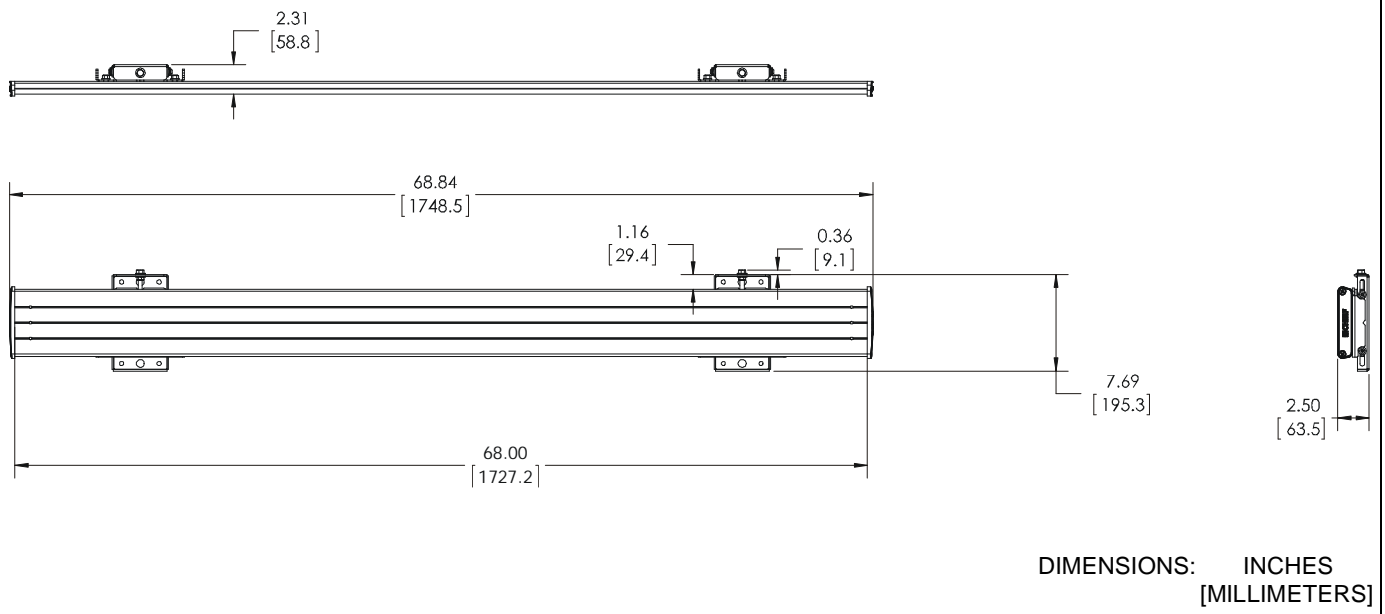



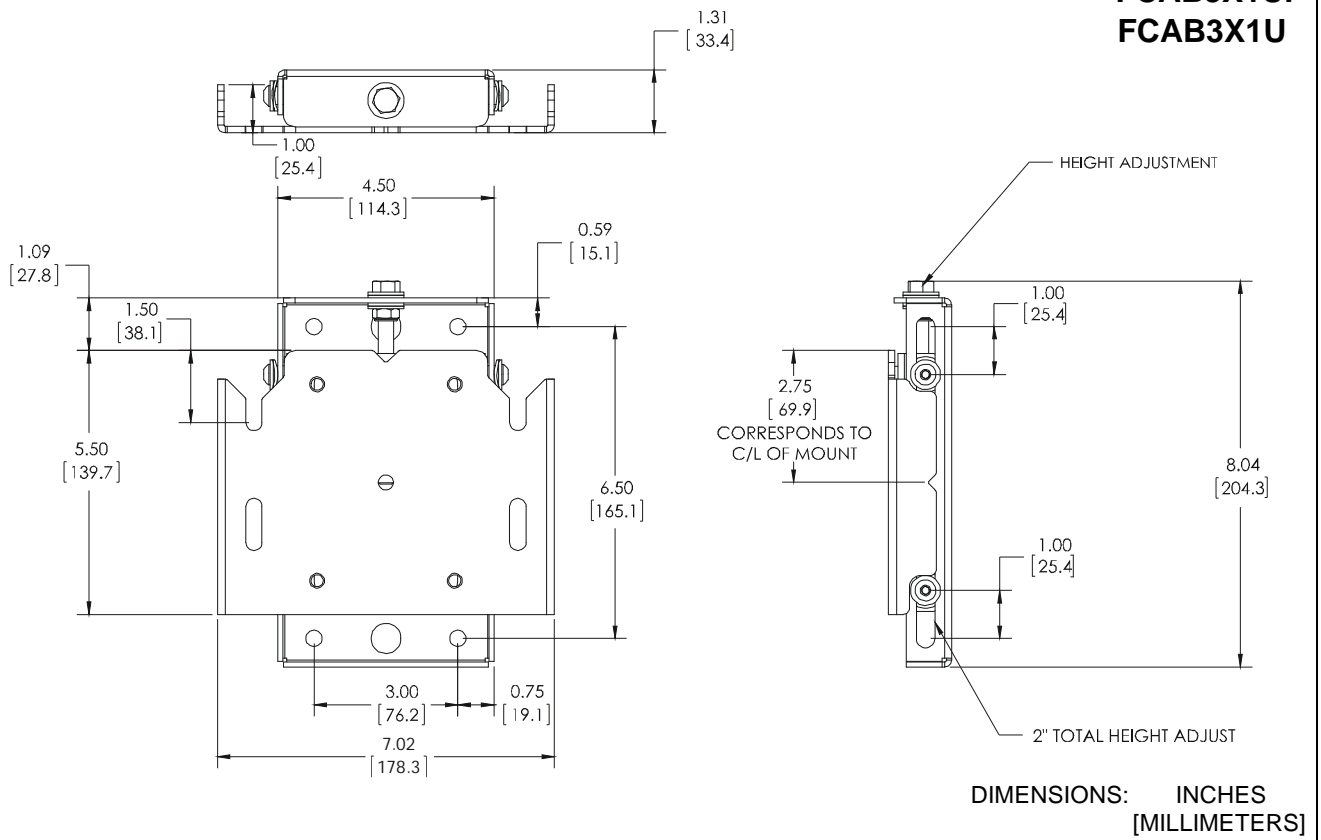



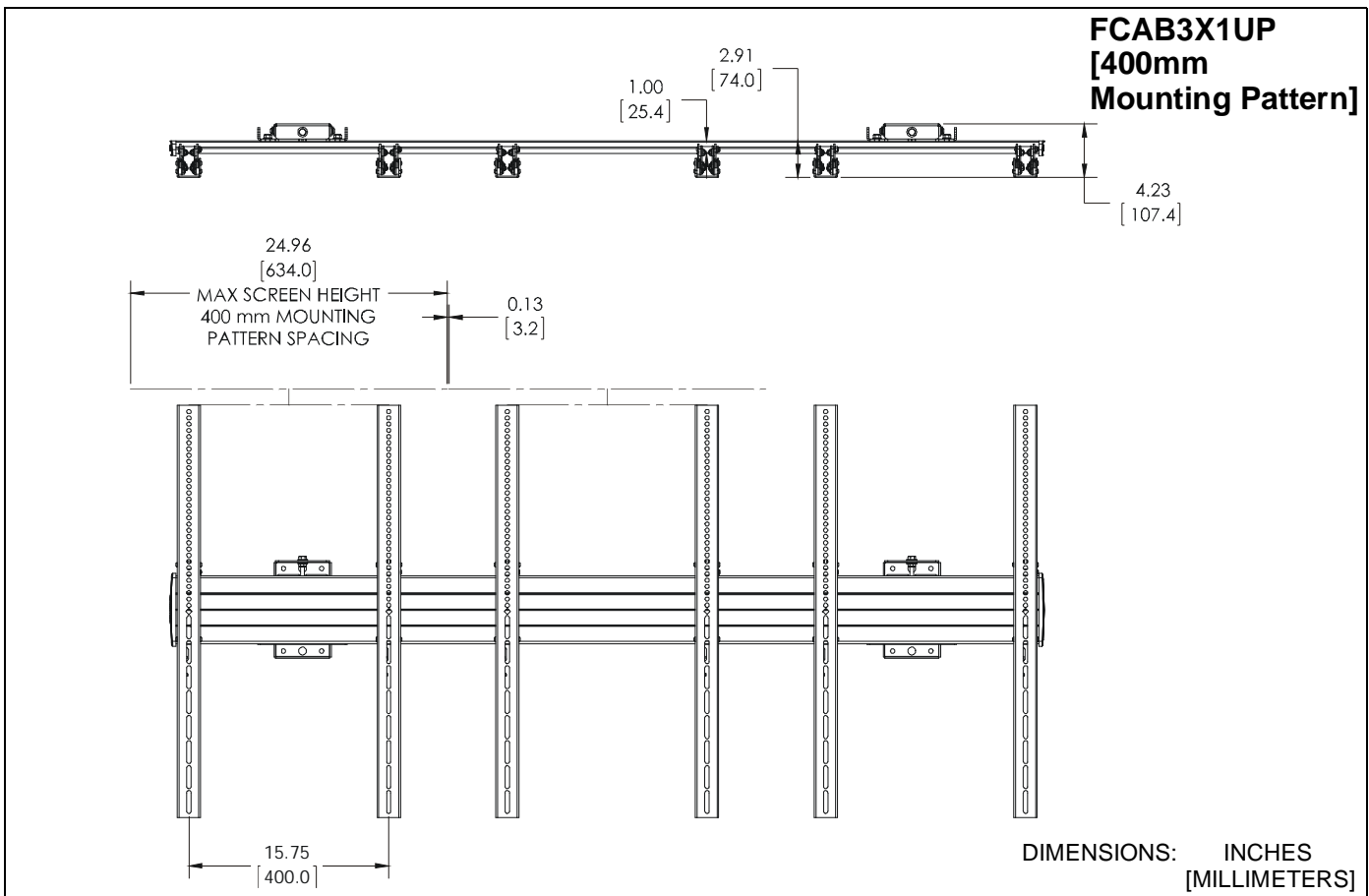
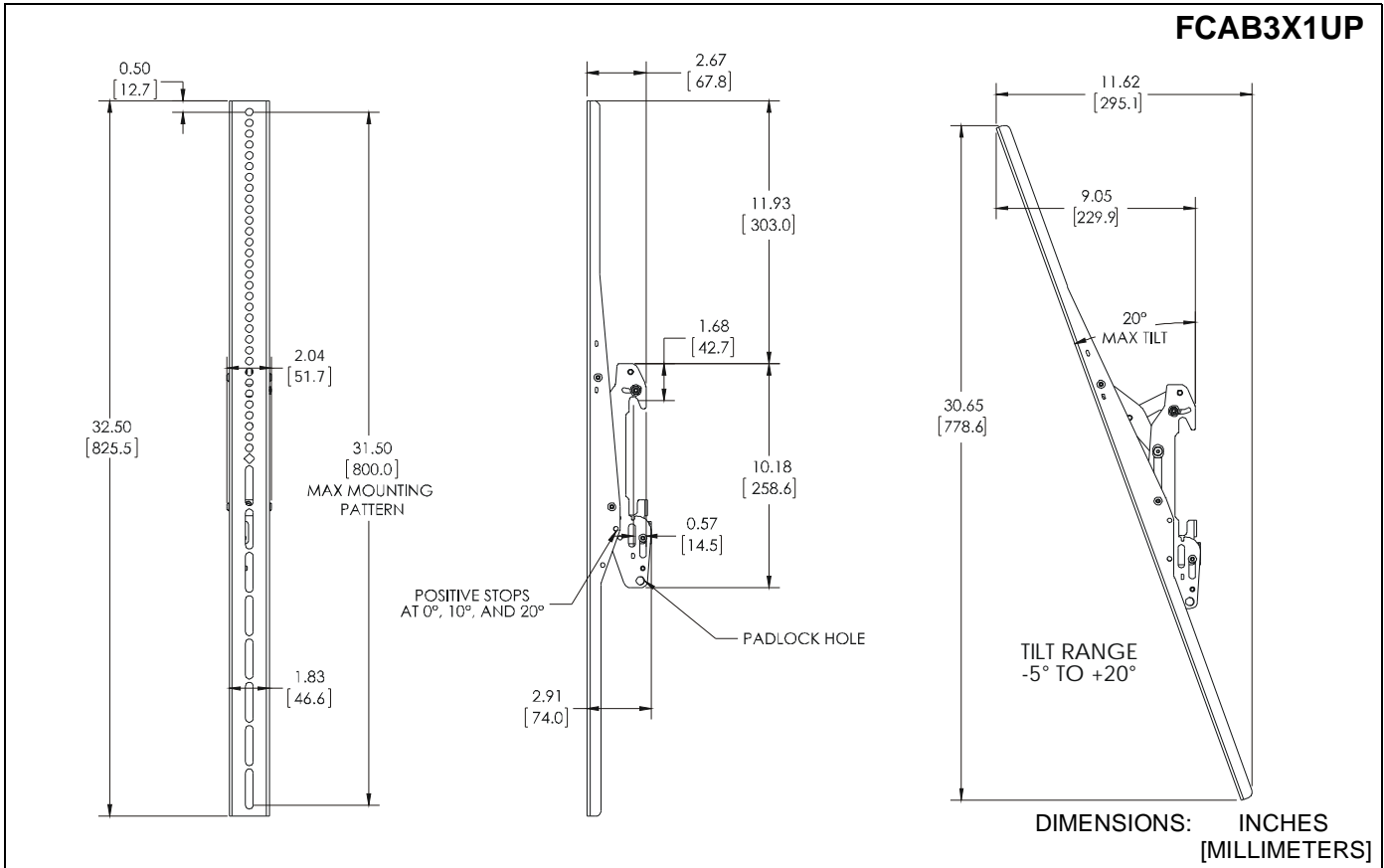



**FCAB3X1UP
FCAB3X1U**

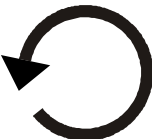

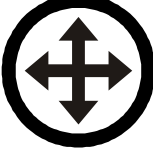
DIMENSIONS (cont'd)



LEGEND

	<p>Tighten Fastener</p> <p>Apretar elemento de fijación</p> <p>Befestigungsteil festziehen</p> <p>Apertar fixador</p> <p>Serrare il fissaggio</p> <p>Bevestiging vastdraaien</p> <p>Serrez les fixations</p>		<p>Pencil Mark</p> <p>Marcar con lápiz</p> <p>Stiftmarkierung</p> <p>Marcar com lápis</p> <p>Segno a matita</p> <p>Potloodmerkteken</p> <p>Marquage au crayon</p>
	<p>Loosen Fastener</p> <p>Aflojar elemento de fijación</p> <p>Befestigungsteil lösen</p> <p>Desapertar fixador</p> <p>Allentare il fissaggio</p> <p>Bevestiging losdraaien</p> <p>Desserrez les fixations</p>		<p>Drill Hole</p> <p>Perforar</p> <p>Bohrloch</p> <p>Fazer furo</p> <p>Praticare un foro</p> <p>Gat boren</p> <p>Percez un trou</p>
	<p>Phillips Screwdriver</p> <p>Destornillador Phillips</p> <p>Kreuzschlitzschraubendreher</p> <p>Chave de fendas Phillips</p> <p>Cacciavite a stella</p> <p>Kruiskopschroevendraaier</p> <p>Tournevis à pointe cruciforme</p>		<p>Adjust</p> <p>Ajustar</p> <p>Einstellen</p> <p>Ajustar</p> <p>Regolare</p> <p>Afstellen</p> <p>Ajuster</p>
	<p>Open-Ended Wrench</p> <p>Llave de boca</p> <p>Gabelschlüssel</p> <p>Chave de bocas</p> <p>Chiave a punte aperte</p> <p>Steeksleutel</p> <p>Clé à fourche</p>		<p>Remove</p> <p>Quitar</p> <p>Entfernen</p> <p>Remover</p> <p>Rimuovere</p> <p>Verwijderen</p> <p>Retirez</p>
	<p>By Hand</p> <p>A mano</p> <p>Von Hand</p> <p>Com a mão</p> <p>A mano</p> <p>Met de hand</p> <p>À la main</p>		<p>Optional</p> <p>Opcional</p> <p>Optional</p> <p>Opcional</p> <p>Opzionale</p> <p>Optie</p> <p>En option</p>
	<p>Hex-Head Wrench</p> <p>Llave de cabeza hexagonal</p> <p>Sechskantschlüssel</p> <p>Chave de cabeça sextavada</p> <p>Chiave esagonale</p> <p>Zeskantsleutel</p> <p>Clé à tête hexagonale</p>		<p>Security Wrench</p> <p>Llave de seguridad</p> <p>Sicherheitsschlüssel</p> <p>Chave de segurança</p> <p>Chiave di sicurezza</p> <p>Veiligheidsleutel</p> <p>Clé de sécurité</p>

TOOLS REQUIRED FOR INSTALLATION

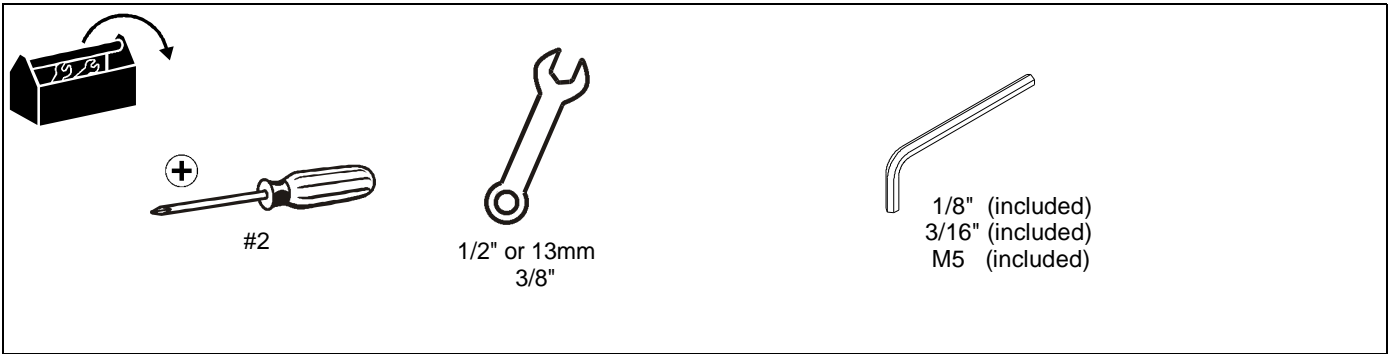

PARTS

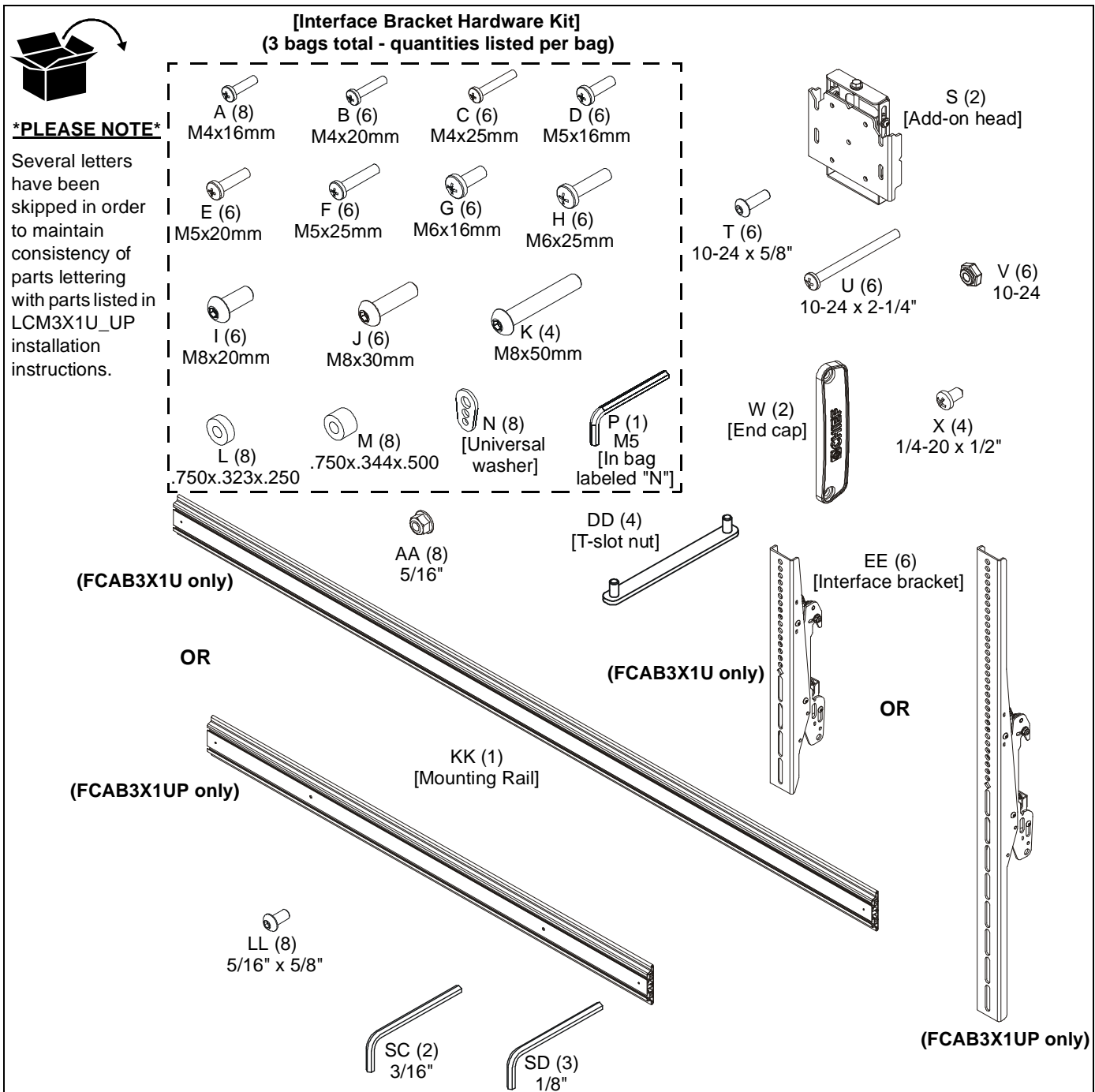

INSTALLATION

The following installation instructions assume that the UL Listed LCM3X1U or LCM3X1UP has been assembled up until the **Attaching Interface Brackets to Displays** section. Refer to LCM3X1U/LCM3X1UP installation instructions for details.

NOTE: The following procedure assumes that two UL Listed CPA or CMA ceiling plates (not included) and two extension columns (not included) have been properly installed following instructions provided with ceiling plates and extension columns.

Attaching Add-On Heads

1. Attach add-on head (S) to existing array head using four 5/16 x 5/8" button head cap screws (LL). (See Figure 1)
2. Repeat Step 1 for remaining add-on head.

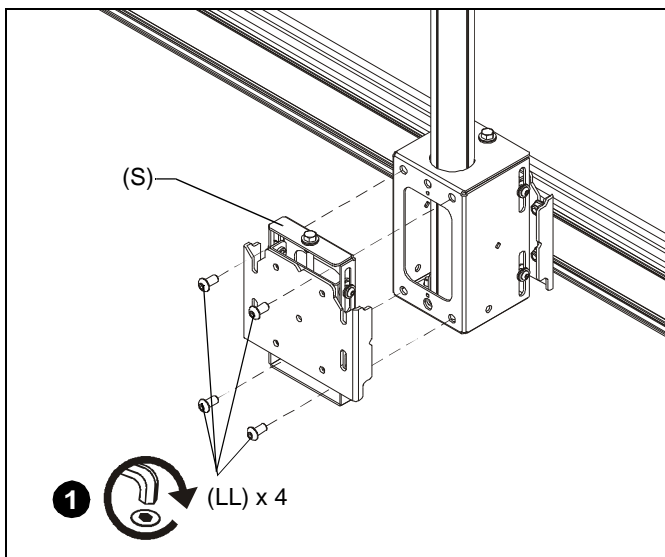

Figure 1

Adding Mounting Rail

1. Slide four T-slot studs (DD - two in top mounting rail slot and two in bottom) into end of mounting rail (KK). (See Figure 2)

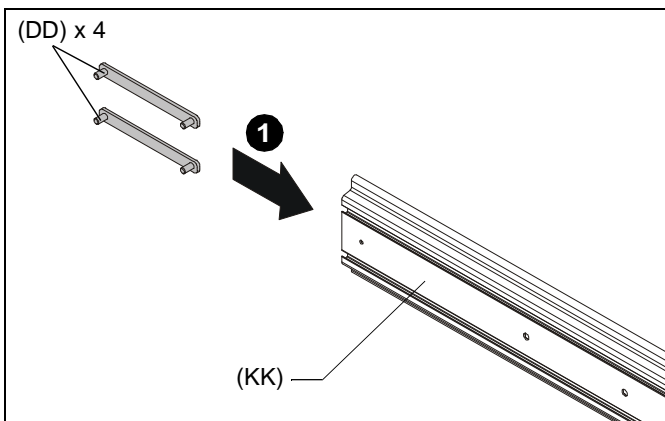

Figure 2

2. Partially fasten one 5/16" lock nut (AA) to each stud on upper T-slot studs.

3. Slide top T-slot studs (DD) with attached lock nuts (AA) down into top openings on add-on heads (S). (See Figure 3)
4. Slide studs on lower T-slot studs (DD) into lower slots on add-on heads (S) while bringing mounting rail against add-on heads.

IMPORTANT ! : Both mounting rails (KK) must be located at the same height. One mounting rail must NOT be higher than the other mounting rail.

5. Tighten array head to mounting rail by tightening lock nuts on upper T-slot studs and adding two 5/16" lock nuts (AA) to lower T-slot studs. (See Figure 3)

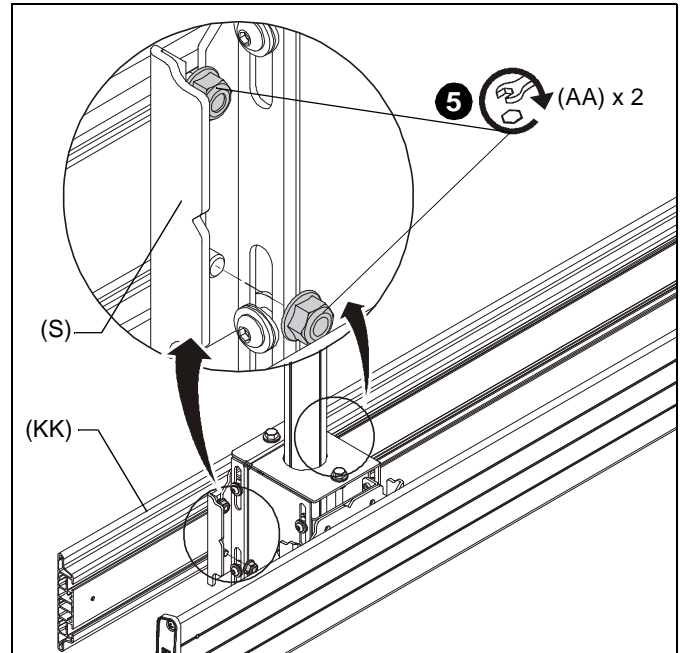

Figure 3

6. Repeat for remaining add-on head (S).
7. Add one end cap (W) to each end of mounting rail (KK), and fasten in place using two 1/4-20 x 1/2" Phillips self-tapping screws (X) for each end cap. (See Figure 4)

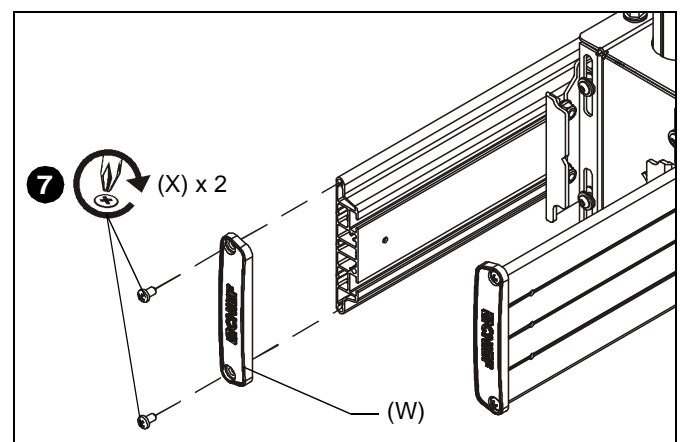

Figure 4

Attaching Interface Brackets to Display

1. Lower the latch mechanism on all interface brackets (EE). (See Figure 5)

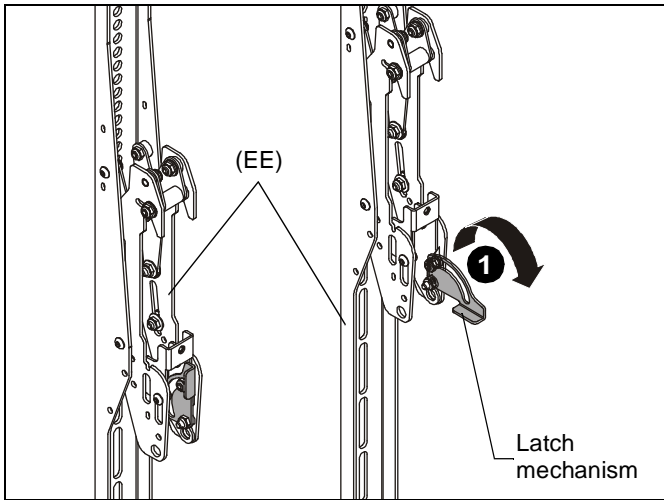

Figure 5

2. Align the center of the interface bracket (EE) with center of display. (See Figure 6)

NOTE: The diamond-shape hole in the bracket corresponds to the center of the mount.

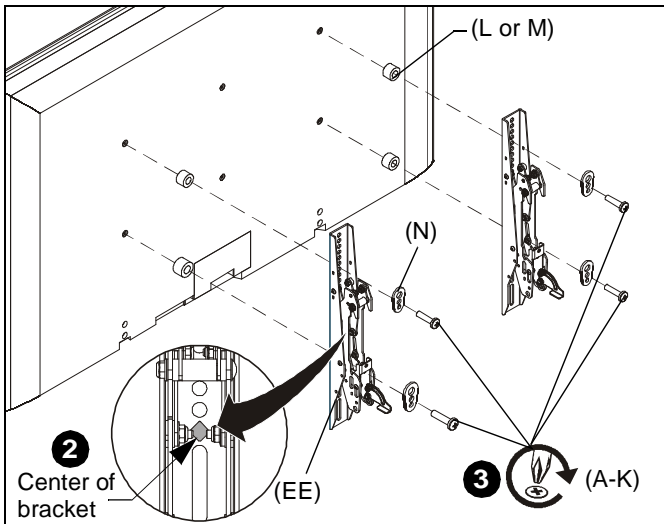

Figure 6

WARNING: IMPROPER INSTALLATION CAN LEAD TO DISPLAY FALLING CAUSING SERIOUS PERSONAL INJURY OR DAMAGE TO EQUIPMENT! Using screws of improper size may damage your display. Properly sized screws will easily and completely thread into display mounting holes. If spacers are required, be sure to use longer screws of the same diameter.

3. Select correct screws, spacers (if necessary) and universal washers from the hardware bag (A-N) and attach brackets (EE) to back of displays. (See Figure 6)

Attaching Displays to Ceiling Mount



WARNING: IMPROPER INSTALLATION CAN LEAD TO DISPLAY FALLING CAUSING SERIOUS PERSONAL INJURY OR DAMAGE TO EQUIPMENT! The weight of the displays must be evenly distributed as the displays are added to the ceiling mount.

IMPORTANT ! : Install displays by placing the first display on the mount, and then adding the second display on the other side of the mount at the opposite end of the mount. Repeat for remaining end displays, and add center displays last. (See Figure 7)

1. Ensure that the latch mechanisms on interface brackets (DD) are already lowered. (See Figure 5)
2. While supporting both sides of display, lower display onto one side of ceiling mount, hooking top of interface brackets onto rail of ceiling mount. (See Figure 8)
3. Raise the latch mechanism on both interface brackets to lock display in place. (See Figure 8)

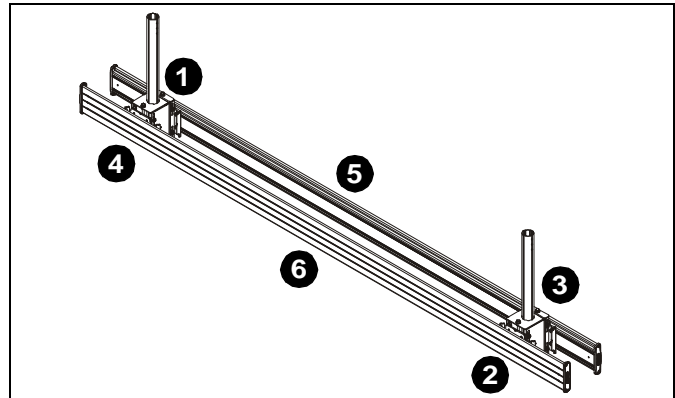

Figure 7

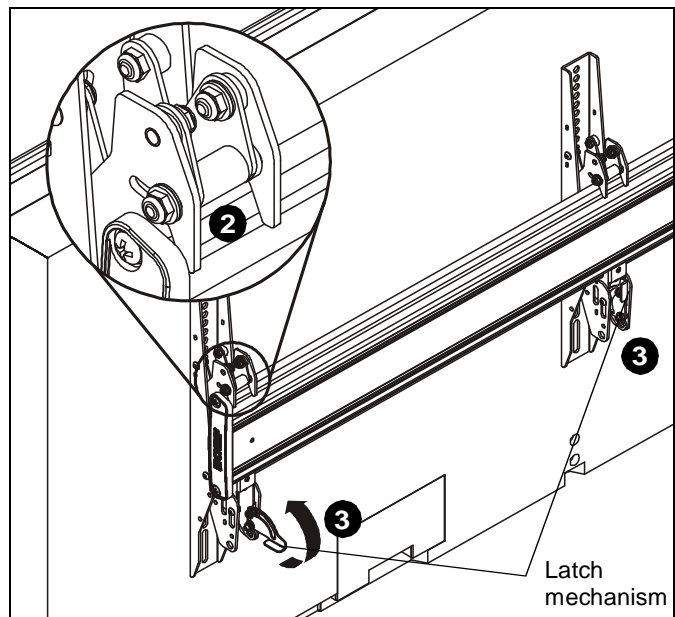

Figure 8

4. Fasten bracket against ceiling mount extrusion using one 10-24 x 5/8" button head cap screw (T). (See Figure 9)
5. Repeat for other interface bracket.

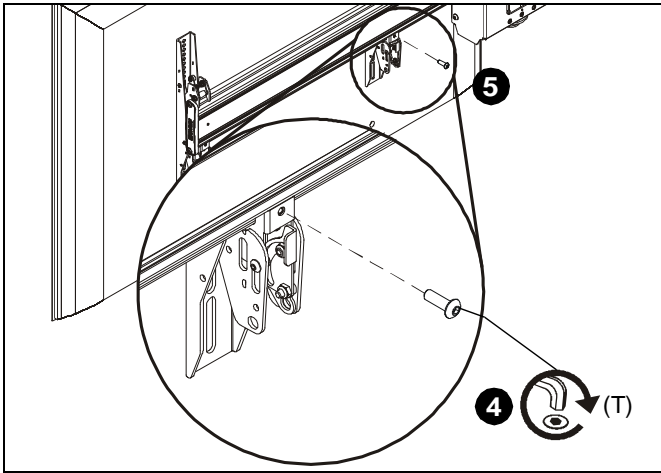

Figure 9

6. Repeat Steps 1 through 5 for all remaining displays.

Adjustments



CAUTION: Watch for pinch points! Do not place fingers between moveable parts.

Height Adjust

The ceiling mounts allow up to 2 inches of height adjustment.

1. Turn the height adjustment bolt(s) in the direction necessary for the desired height. (See Figure 10)

NOTE: Each height adjustment bolt controls the height on its side of the mount.

IMPORTANT ! : Both mounting rails must be located at the same height. One mounting rail must NOT be higher than the other mounting rail.

2. Stop adjusting when the desired setting is reached.

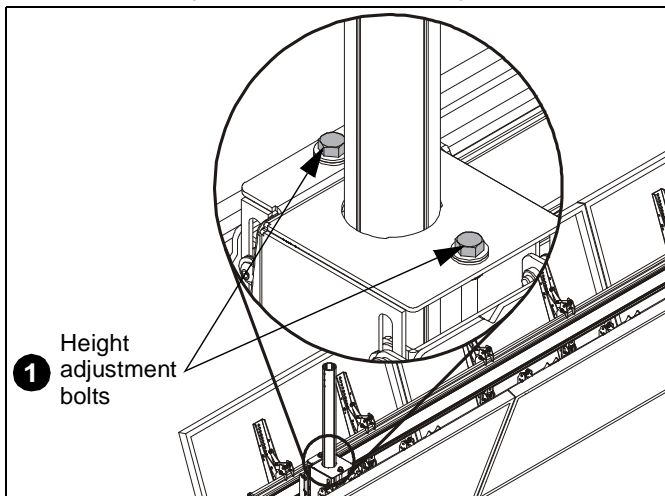

Figure 10

Tilt

The interface brackets allow -5° to 20° tilt, and can be locked at 0°, 10° and 20° tilt.

3. If necessary, loosen button head tilt friction bolt (located on side of interface bracket). (See Figure 11)
4. Adjust tilt as required. (See Figure 11)
5. The tilt may be locked at 0°, 10° and 20° using one 10-24 x 2-1/4" Phillips head screw (U) and one 10-24 lock nut (V) per interface bracket. (See Figure 11)
6. Tighten button head tilt friction bolt as necessary. (See Figure 11)

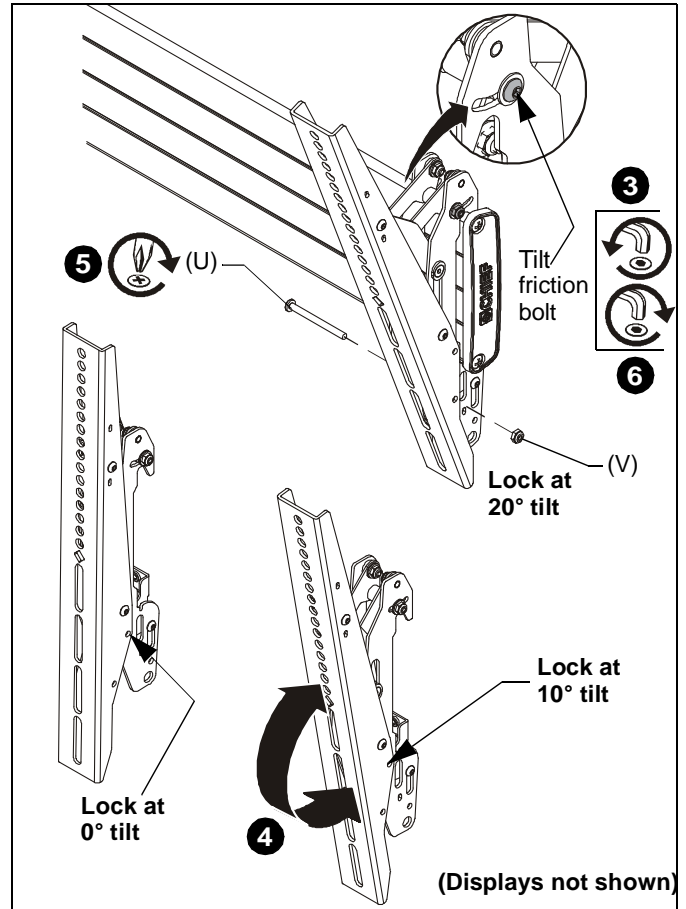

Figure 11

Security (OPTIONAL)

1. Add padlock (not included) to each interface bracket to lock display to ceiling mount. (See Figure 12)

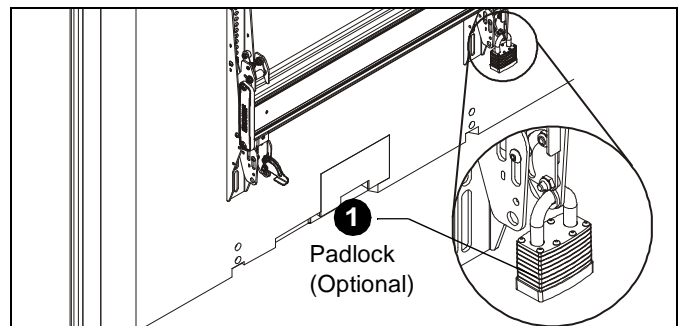

Figure 12



Our Mounts. **Your Vision.**

Chief Manufacturing, a products division
of Milestone AV Technologies

8800-002383 Rev00
©2013 Milestone AV Technologies, a
Duchossois Group Company
www.chiefmfg.com
11/13

USA/International	A 6436 City West Parkway, Eden Prairie, MN 55344 P 800.582.6480 / 952.225.6000 F 877.894.6918 / 952.894.6918
Europe	A Franklinstraat 14, 6003 DK Weert, Netherlands P +31 (0) 495 580 852 F +31 (0) 495 580 845
Asia Pacific	A Office No. 1 on 12/F, Shatin Galleria 18-24 Shan Mei Street Fotan, Shatin, Hong Kong P 852 2145 4099 F 852 2145 4477

