

INSTALLATION INSTRUCTIONS

Instrucciones de instalación
Installationsanleitung
Instruções de Instalação

Istruzioni di installazione
Installatie-instructies
Instructions d'installation

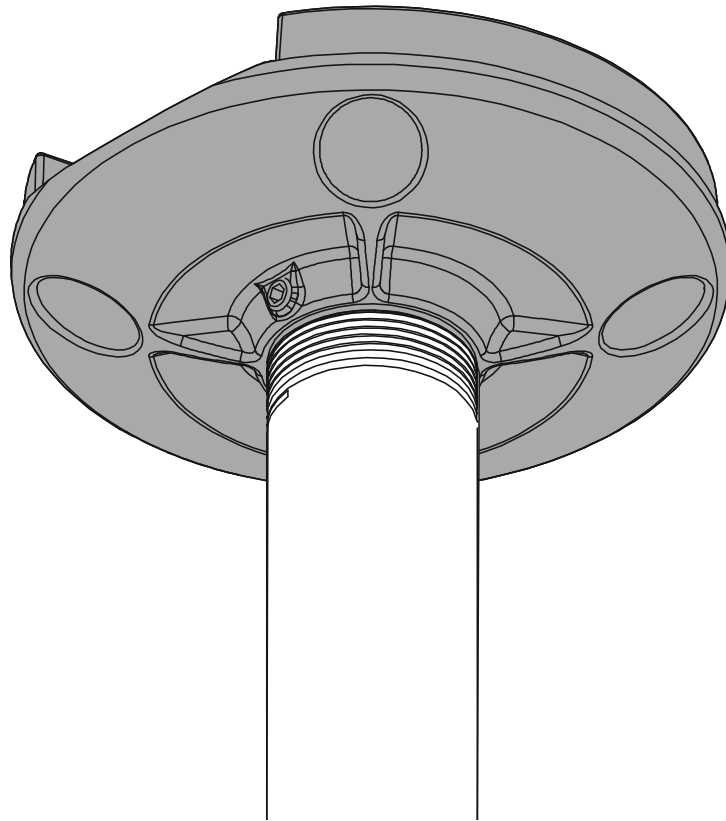

Ceiling Plate

Placa de techo
Deckenplatte
Chapa de teto
Piastra per soffitto
Plafondplaat
Plaque de plafond

DISCLAIMER

Milestone AV Technologies, and its affiliated corporations and subsidiaries (collectively, "Milestone"), intend to make this manual accurate and complete. However, Milestone makes no claim that the information contained herein covers all details, conditions or variations, nor does it provide for every possible contingency in connection with the installation or use of this product. The information contained in this document is subject to change without notice or obligation of any kind. Milestone makes no representation of warranty, expressed or implied, regarding the information contained herein. Milestone assumes no responsibility for accuracy, completeness or sufficiency of the information contained in this document.

Chief® is a registered trademark of Milestone AV Technologies. All rights reserved.

IMPORTANT WARNINGS AND CAUTIONS!

 **WARNING:** A WARNING alerts you to the possibility of serious injury or death if you do not follow the instructions.

 **CAUTION:** A CAUTION alerts you to the possibility of damage or destruction of equipment if you do not follow the corresponding instructions.

 **WARNING:** Failure to read, thoroughly understand, and follow all instructions can result in serious personal injury, damage to equipment, or voiding of factory warranty! It is the installer's responsibility to make sure all components are properly assembled and installed using the instructions provided.

 **WARNING:** Failure to provide adequate structural strength for this component can result in serious personal injury or damage to equipment! It is the installer's responsibility to make sure the structure to which this component is attached can support five times the combined weight of all equipment. Reinforce the structure as required before installing the component.

 **WARNING:** Exceeding the weight capacity can result in serious personal injury or damage to equipment! It is the installer's responsibility to make sure the combined weight of all components attached to the CMS115 does not exceed 500 lbs (227 kg).

¡AVISOS y PRECAUCIONES IMPORTANTES!

 **AVISO:** Un AVISO llama su atención sobre la posibilidad de sufrir lesiones de gravedad o incluso mortales si no sigue las

instrucciones.

 **PRECAUCIÓN:** Una nota de PRECAUCIÓN llama su atención sobre la posibilidad de dañar o destruir el equipo si no sigue las instrucciones.

 **AVISO:** Si no lee, comprende perfectamente y sigue todas las instrucciones, podría causar graves daños personales y materiales o anular la garantía de fábrica. El instalador es el responsable de asegurarse de que todos los componentes están correctamente montados e instalados siguiendo las instrucciones indicadas.

 **AVISO:** Si no se proporciona la resistencia estructural adecuada para este componente, podrían provocarse graves daños personales o materiales. El instalador es el responsable de asegurarse de que la estructura a la que este componente está sujeta puede soportar cinco veces el peso combinado de todo el equipo. Refuerce la estructura según sea necesario antes de instalar el componente.

 **AVISO:** Si se excede el peso máximo, podrían causarse graves daños personales o materiales. El instalador es responsable de asegurarse de que el peso combinado de todos los componentes montados en el CMS115 no excede 227 kg (500 libras).

WICHTIGE WARN- und VORSICHTSHINWEISE!

 **WARNUNG:** Ein WARNHINWEIS macht auf mögliche schwere oder tödliche Verletzungen aufmerksam, die bei Nichtbefolgung der Anweisungen eintreten können.

 **VORSICHT:** Ein VORSICHTSHINWEIS macht auf Schäden oder mögliche Zerstörung des Geräts aufmerksam, die bei Nichtbefolgung der Anweisungen eintreten können.

 **WARNUNG:** Falls nicht alle Anweisungen gelesen und gut verstanden werden, kann dies zu schweren Körperverletzungen, Schaden an den Geräten führen und die Werksgarantie nichtig machen! Der Monteur ist dafür verantwortlich, dass alle Komponenten unter Einhaltung der mitgelieferten Anweisungen korrekt zusammengebaut und eingebaut werden.

 **WARNUNG:** Wenn für diese Komponente keine ausreichende bauliche Tragkraft vorhanden ist, kann dies zu schweren Körperverletzungen oder Schäden an den Geräten führen! Der Installateur ist dafür verantwortlich zu überprüfen,

ob die Wand, an der diese Komponente verankert wird, das Fünffache der Gesamtlast aller befestigten Geräte sicher tragen kann. Andernfalls muss die Wand verstärkt werden, bevor die Komponente angebracht wird.



AVVERTENZA: Wenn das zulässige Gewicht überschritten wird, kann dies zu schweren Körperverletzungen oder Schäden an den Geräten führen! Der Monteur ist dafür verantwortlich, dass das kombinierte Gewicht aller Komponenten, die am Modell CMS115 befestigt sind, nicht mehr als 227 kg beträgt.



ADVERTÊNCIAS e AVISOS IMPORTANTES!



ADVERTÊNCIA: Os alertas de ADVERTÊNCIA avisam-no para a possibilidade de ocorrência de graves lesões ou morte no caso de incumprimento das instruções.



AVISO: Os alertas de AVISO avisam-no para a possibilidade de danos ou destruição do equipamento no caso de incumprimento das instruções.



ADVERTÊNCIA: Se não ler, compreender completamente e seguir todas as instruções podem ocorrer graves lesões pessoais, danos no equipamento e a garantia de fábrica pode ser anulada! É da responsabilidade do instalador certificar-se de que todos os componentes são correctamente montados e instalados de acordo com as instruções fornecidas.



ADVERTÊNCIA: Se não for proporcionado apoio estrutural adequado a este componente podem ocorrer graves lesões pessoais ou danos no equipamento! É da responsabilidade do instalador certificar-se de que a estrutura à qual este componente é ligado pode suportar cinco vezes o peso combinado de todo o equipamento. Reforce a estrutura conforme necessário antes de instalar o componente.



ADVERTÊNCIA: Exceder a capacidade de peso pode resultar em graves lesões pessoais ou danos no equipamento! É da responsabilidade do instalador certificar-se de que o peso combinado de todos os componentes ligados ao CMS115 não excede 227 kg.



AVVERTENZE e PRECAUZIONI IMPORTANTI!



AVVERTENZA: Un'AVVERTENZA mette in guardia in merito alla possibilità di gravi infortuni, anche letali, qualora non si

osservino le istruzioni.



ATTENZIONE: Un'ATTENZIONE indica la possibilità di gravi danni all'attrezzatura qualora non ci si attiene alle istruzioni al riguardo.



AVVERTENZA: La mancata comprensione e ottemperanza alle istruzioni fornite può provocare gravi lesioni personali, danni all'apparecchiatura o annullare la garanzia fornita dal produttore. Spetta all'installatore verificare che tutti i componenti siano assemblati correttamente e installati secondo le istruzioni fornite.



AVVERTENZA: Una resistenza strutturale inadeguata per questo componente può arrecare gravi infortuni o danneggiare l'apparecchiatura. È responsabilità dell'installatore verificare che la struttura alla quale è fissato il componente sostenga con sicurezza cinque volte il carico combinato di tutta l'apparecchiatura. Rinforzare la struttura secondo necessità prima di installare i componenti.



AVVERTENZA: Un peso superiore alla capacità nominale può arrecare gravi infortuni o danneggiare l'apparecchiatura. È responsabilità dell'installatore verificare che il peso totale di tutti i componenti montati sul CMS115 non superi 227 kg (500 lb).



BELANGRIJKE AANWIJZINGEN en WAARSCHUWINGEN!



WAARSCHUWING: Een WAARSCHUWING vestigt uw aandacht op de mogelijkheid van ernstig of dodelijk letsel als u de instructies niet opvolgt.



VOORZICHTIG: De aanwijzing VOORZICHTIG vestigt uw aandacht op de mogelijkheid van beschadiging of onherstelbare beschadiging van de apparatuur als u de betreffende instructies niet opvolgt.



WAARSCHUWING: Door niet alle instructies te lezen, volledig te begrijpen en op te volgen, riskeert u ernstig persoonlijk letsel, beschadiging van de apparatuur en het vervallen van de fabrieksgarantie. Degene die het product installeert is ervoor verantwoordelijk dat alle onderdelen aan de hand van de meegeleverde handleiding op de juiste wijze worden samengebouwd en gemonteerd.



WAARSCHUWING: Als u voor deze component onvoldoende constructiesterke beschikbaar stelt, riskeert u ernstig persoonlijk letsel of beschadiging van de apparatuur!

Degene die de structuur monteert waaraan deze component is bevestigd, is ervoor verantwoordelijk dat deze minimaal vijf maal het gezamenlijke gewicht van alle apparatuur kan dragen. Zonodig dient u de structuur vóór de montage van de component te versterken.



WAARSCHUWING: Overschrijding van het draagvermogen kan de oorzaak zijn van ernstig persoonlijk letsel en beschadiging van de apparatuur! Degene die het product installeert is ervoor verantwoordelijk dat het totale gewicht van alle componenten die aan de CMS115 worden bevestigd een gewicht van 227 kg niet overschrijdt.



IMPORTANT Avertissements et Précautions!



ADVERTISSEMENT: Un ADVERTISSEMENT vous met en garde contre les possibilités de blessures graves ou de danger de mort si vous ne suivez pas les instructions.



PRÉCAUTION: Une PRÉCAUTION vous met en garde contre les possibilités d'endommagements et de destruction de l'équipement si vous ne suivez pas les instructions

correspondantes.



ADVERTISSEMENT: Le manque de la lecture, de la compréhension et du respect total de toutes les instructions, peut entraîner des blessures corporelles graves, endommager l'équipement ou annuler la garantie d'usine. Il incombe à l'installateur de s'assurer que tous les composants sont correctement assemblés et installés à l'aide des instructions fournies.



ADVERTISSEMENT: L'absence de l'apport d'une résistance structurelle appropriée pour ce composant peut entraîner des blessures corporelles graves ou endommager l'équipement. Il incombe à l'installateur de s'assurer que la structure à laquelle le composant est attaché peut soutenir cinq fois le poids combiné de tout l'équipement. Renforcer la structure selon les besoins avant l'installation du composant.



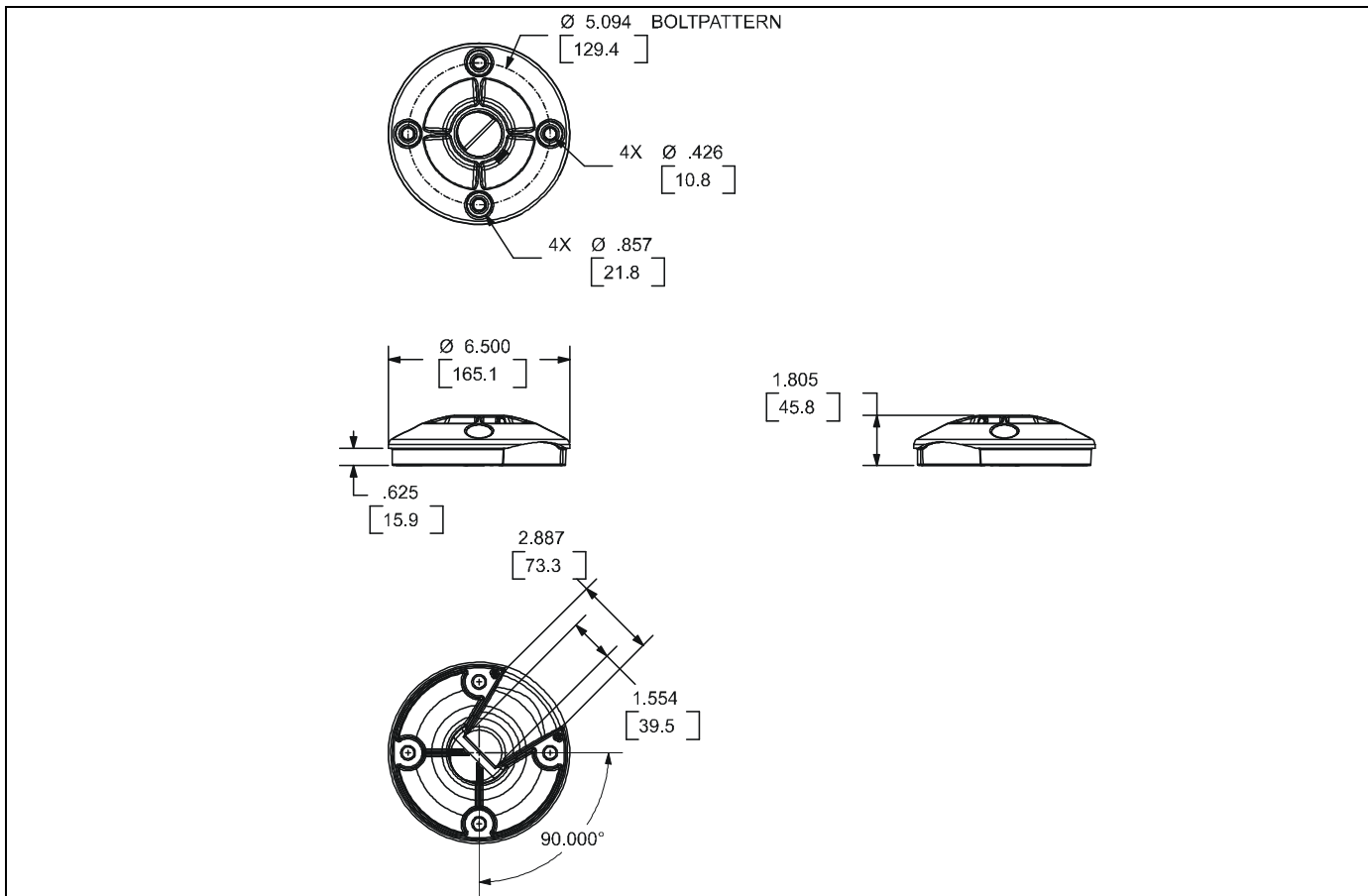

ADVERTISSEMENT: Dépassez la capacité pondérale peut entraîner des blessures corporelles graves ou endommager l'équipement. Il incombe à l'installateur de s'assurer que le poids combiné de tous les composants attachés à CMS115 n'est pas supérieur à 227 kg (500 lb).

DIMENSIONS



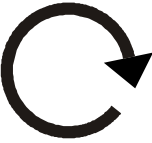

LEGEND

	Tighten Fastener
	Apretar elemento de fijación
	Befestigungsteil festziehen
	Apertar fixador
	Serrare il fissaggio
	Bevestiging vastdraaien
Serrez les fixations	

	Drill Hole
	Perforar
	Bohrloch
	Fazer furo
	Praticare un foro
	Gat boren
Percez un trou	

	Loosen Fastener
	Aflojar elemento de fijación
	Befestigungsteil lösen
	Desapertar fixador
	Allentare il fissaggio
	Bevestiging losdraaien
Desserrez les fixations	

	Optional
	Opcional
	Optional
	Opcional
	Opzionale
	Optie
En option	

	Socket Wrench
	Llave de cubo
	Steckschlüssel
	Chave de caixa
	Chiave a brugola
	Dopsleutel
Clé à douilles	

	Hex-Head Wrench
	Llave de cabeza hexagonal
	Sechskantschlüssel
	Chave de cabeça sextavada
	Chiave esagonale
	Zeskantsleutel
Clé à tête hexagonale	

	By Hand
	A mano
	Von Hand
	Com a mão
	A mano
	Met de hand
À la main	

	Security Wrench
	Llave de seguridad
	Sicherheitsschlüssel
	Chave de segurança
	Chiave di sicurezza
	Veiligheidssleutel
Clé de sécurité	

	Pencil Mark
	Marcar con lápiz
	Stiftmarkierung
	Marcar com lápis
	Segno a matita
	Potloodmerkteken
Marquage au crayon	

TOOLS REQUIRED FOR INSTALLATION

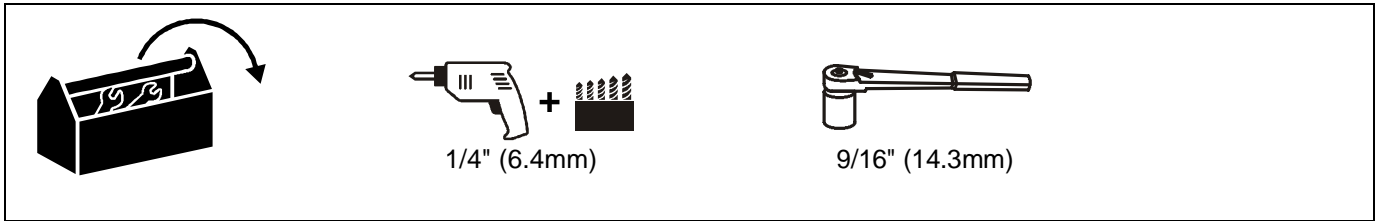

PARTS

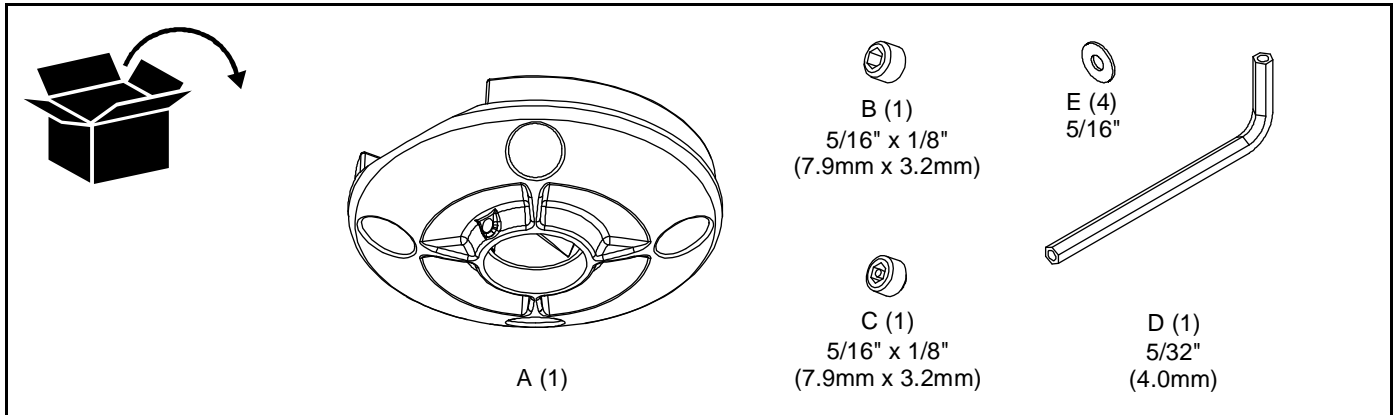

INSTALLATION



WARNING: Failure to provide adequate structural strength for this component can result in serious personal injury or damage to equipment! It is the installer's responsibility to make sure the structure to which this component is attached can support five times the combined weight of all equipment. Reinforce the structure as required before installing the component.

- Using plate (A) as a template, mark locations of two pilot holes (See Figure 1). Ensure the following:
 - *Opposite* holes in plate (A) are marked, and
 - Marks are in the center of wood joist.

NOTE: Drywall not shown for clarity.

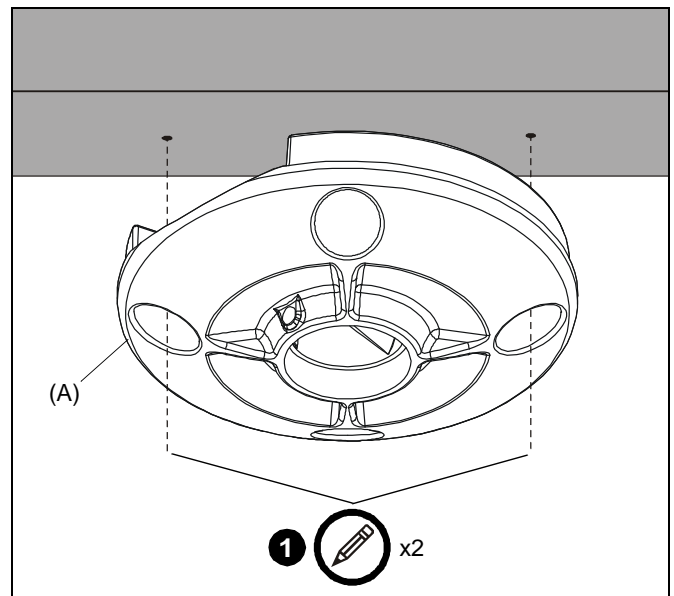

Figure 1

- Drill 1/4" (6.4mm) diameter pilot holes into wood joist (See Figure 2). Ensure pilot holes are straight.

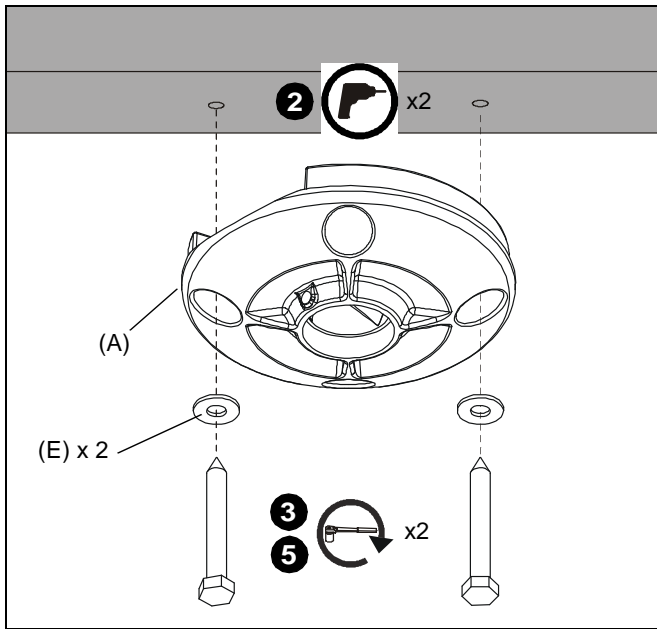

Figure 2

- Using 9/16" (14.3mm) socket wrench, loosely install 3/8" x 2-1/2" (9.5mm x 63.5mm) lag screws through 5/16" (7.9mm) washers (E), plate (A), into wood joist (See Figure 2). Do not tighten plate (A) against ceiling at this time to accommodate cable installation.

NOTE: Lag screws are not provided. Two additional washers are provided.

- Route cables through channel in plate (A) (See Figure 3).

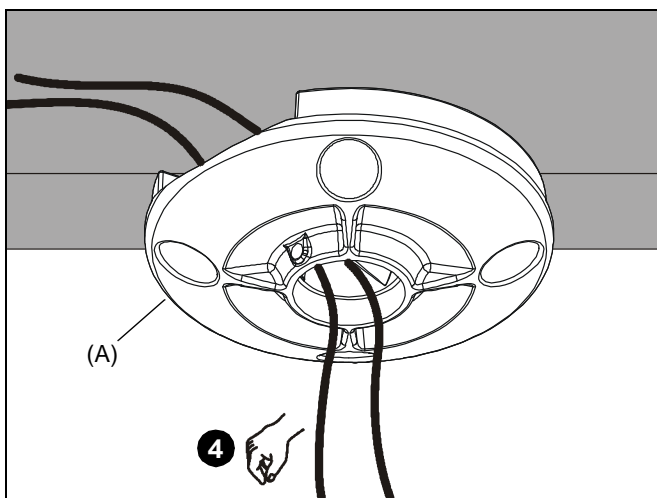

Figure 3

- Tighten lag screws (See Figure 2).



WARNING: Exceeding the weight capacity can result in serious personal injury or damage to equipment! It is the installer's responsibility to make sure the combined weight of all components attached to the CMS115 does not exceed 500 lbs (227 kg).

- Route cables through extension column (1-1/2" NPT thread; accessory not included), then install column to plate (A). See installation instructions included with the accessory.

NOTE: If installation instructions are not available, contact Chief Manufacturing for assistance.

- Using hex key (D), secure extension column by one of the following methods (See Figure 4):

- Install screw (B) into threaded hole, tightening firmly against column.
- OPTIONAL:** Install security screw (C) into threaded hole, tightening firmly against column.

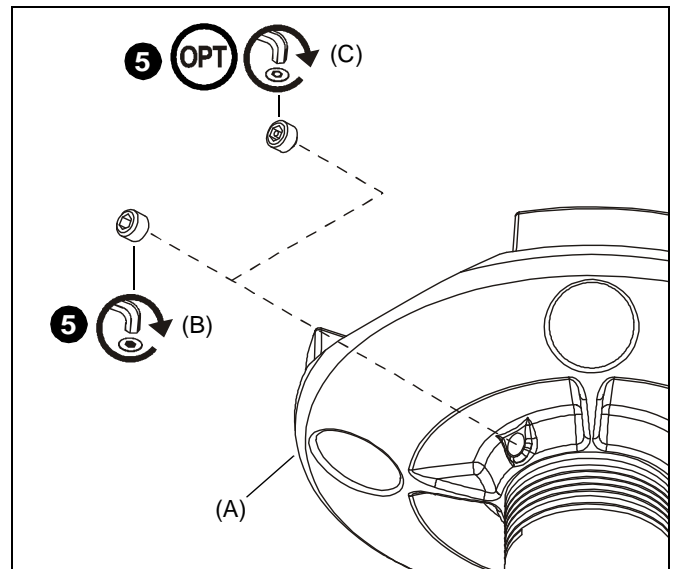

Figure 4



**MANUFACTURERS
DECLARATION OF CONFORMITY**

For

Product identification:

Model/type : CMS115
 Category (description) : Mounting devices, Stands and other Accessories, to be used with entertainment electronics
 Brand : Chief

Manufacturer: Milestone AV Technologies
 8401 Eagle Creek Parkway
 Savage, MN 55378

EU Representative: Milestone AV Technologies
 Fellennoord 130 5611
 ZB Eindhoven
 The Netherlands
 31 (0)20 5708923

Concerning			
	EMC	Safety	
A sample of the product has been tested by:	Not Applicable	CSAV Inc.	
Test report reference			
Applied standards		EN 60065 :2002	

Means of conformity

We declare under our sole responsibility that this product is in conformity with Directive 93/68/EEC (Marking), 98/37/EC (Machinery) 2001/95/EC (Safety) and/or complies to the essential requirements and all other relevant provisions of the based on test results using (non)harmonized standards in accordance with the Directives mentioned

THIS PAGE INTENTIONALLY BLANK.

THIS PAGE INTENTIONALLY BLANK.

THIS PAGE INTENTIONALLY BLANK.



Our Mounts. **Your Vision.**

Chief Manufacturing, a products division
of Milestone AV Technologies

8803-000070 Rev C

©2008 Milestone AV Technologies -

A Duchossois Group Company

www.chiefmfg.com

11/08

USA/International

A 8401 Eagle Creek Parkway, Savage, MN 55378

P 800.582.6480 / 952.894.6280

F 877.894.6918 / 952.894.6918

Europe

A Fellenoord 130 5611 ZB EINDHOVEN, The Netherlands

P +31 (0)40 2668620

F +31 (0)40 2668615

Asia Pacific

A Room 24F, Block D, Lily YinDu International Building

LuoGang, BuJi Town, Shenzhen, CHINA.

深圳市布吉罗岗村百合银都国际大厦D栋24F

P +86-755-8996 9226

F +86-755-8996 9217

