

---

# INSTALLATION INSTRUCTIONS

---

## Vibration Mount

### Model CMA-347

The Chief CMA-347 Vibration Mount is designed to dampen shock and vibration between a mounted item and its structural mounting surface.

Any lengths of standard NPT 1 1/2" pipe, threaded on both ends, can be used to extend the height capabilities to meet your needs.

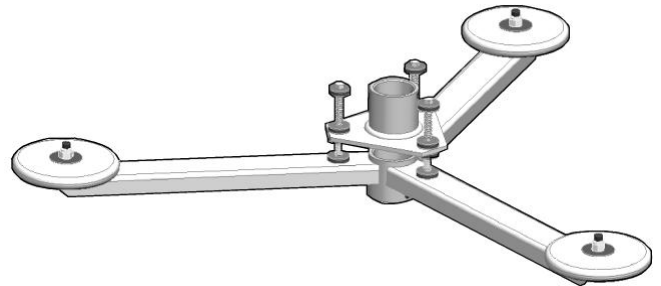

#### BEFORE YOU BEGIN

---

**CAUTION:** To prevent damage to the mount, which could void factory warranty and affect the attached equipment, thoroughly study all instructions and illustrations before you begin the installation. Pay particular attention to the "Important Warnings and Precautions" on Page 1.

- The maximum weight to be installed on the CMA-347 mount is 35 pounds (15.88 Kg).
- If you have any questions about this installation, contact Chief Manufacturing at 1-800-582-6480.



CHIEF MANUFACTURING INC.  
1-800-582-6480 952-894-6280 FAX 952-894-6918  
8401 EAGLE CREEK PARKWAY, STE 700  
SAVAGE, MINNESOTA 55378 USA

8803-000044 (Rev. D)  
©2007 Chief Manufacturing  
[www.chiefmfg.com](http://www.chiefmfg.com)  
09/07

---



**IMPORTANT WARNINGS AND CAUTIONS!**

**WARNING:** A WARNING alerts you to the possibility of serious injury or death if you do not follow the instructions.

**CAUTION:** A CAUTION alerts you to the possibility of damage or destruction of equipment if you do not follow the corresponding instructions.

**WARNING:** Improper installation can result in serious personal injury! Make sure that the structural members can support a weight factor five times the total weight of the equipment. If not, reinforce the structure before installing the mount.

**WARNING:** Be aware also of the potential for personal injury or damage to the unit if it is not adequately mounted.

**WARNING:** The installer is responsible for verifying that the structure to which the mount is anchored will safely support four times the combined load of all attached components or other equipment.

**WARNING:** The weight of the display placed on the CMA-347 must not exceed 35 lbs. (15.88 kg), the maximum load capacity of the CMA-347.

**CAUTION:** Check the unit for shipping damage before you begin the installation.

**CONTENTS**

IMPORTANT WARNINGS AND CAUTIONS! ..... 2  
 PARTS ..... 3  
 INSPECT MOUNT BEFORE INSTALLATION ..... 4  
 MOUNT INSTALLATION ..... 4  
 Set-Up ..... 5  
     Set-up For 15 Pounds and Under ..... 5  
     Set-up For Over 15 Pounds ..... 6  
 Mount Removal ..... 7

**PARTS**

Item	Nomenclature	Qty	Item	Nomenclature	Qty.
10	CMA-347 Top	1	130	WASHER, Fender, 1" OD	24
20	CMA-347 Bottom	1	140	NUT, Nylock, 3/8-16	3
30	WEIGHT, 2.5 Pound	3	150	SCREW, Cap, Hex Head, 3/8-16 x 1.5"	3
40	DAMPER, Sorbothane, Stepped	3	160	SCREW, Set, Socket Head, 5/16-18x3/8" (not shown)	2
50	DAMPER, Sorbothane	12	170*	KEY, Hex, 5/32" (not shown)	1
60	WASHER, Flat, 1/4"	3	180	Plate, Ceiling, Projector Mounting (not shown or supplied)	1
70	SPRING, Small	6	190	Pipe, Upper mounting, NPT 1 1/2" (not shown or supplied)	1
80	SPRING, Long Medium Gauge	3	200	Pipe, Lower Mounting, NPT 1 1/2" (not shown or supplied)	1
90*	SPRING, Long Heavy Gauge	3	210	Mount, Projector (not shown or supplied)	1
100*	BUSHING, Vibration, Stepped	6			
110	NUT, Nylock, 1/4-20	3			
120	BOLT, Hex Tap, 1/4-20 x 4"	3			

\* Items 90 - 100 are included in the accessory pack and used when configuring mount for applications over 15lbs..

Items 160 and 170 are located in the accessory pack and used in all applications to install the CMA-347 Vibration Mount.

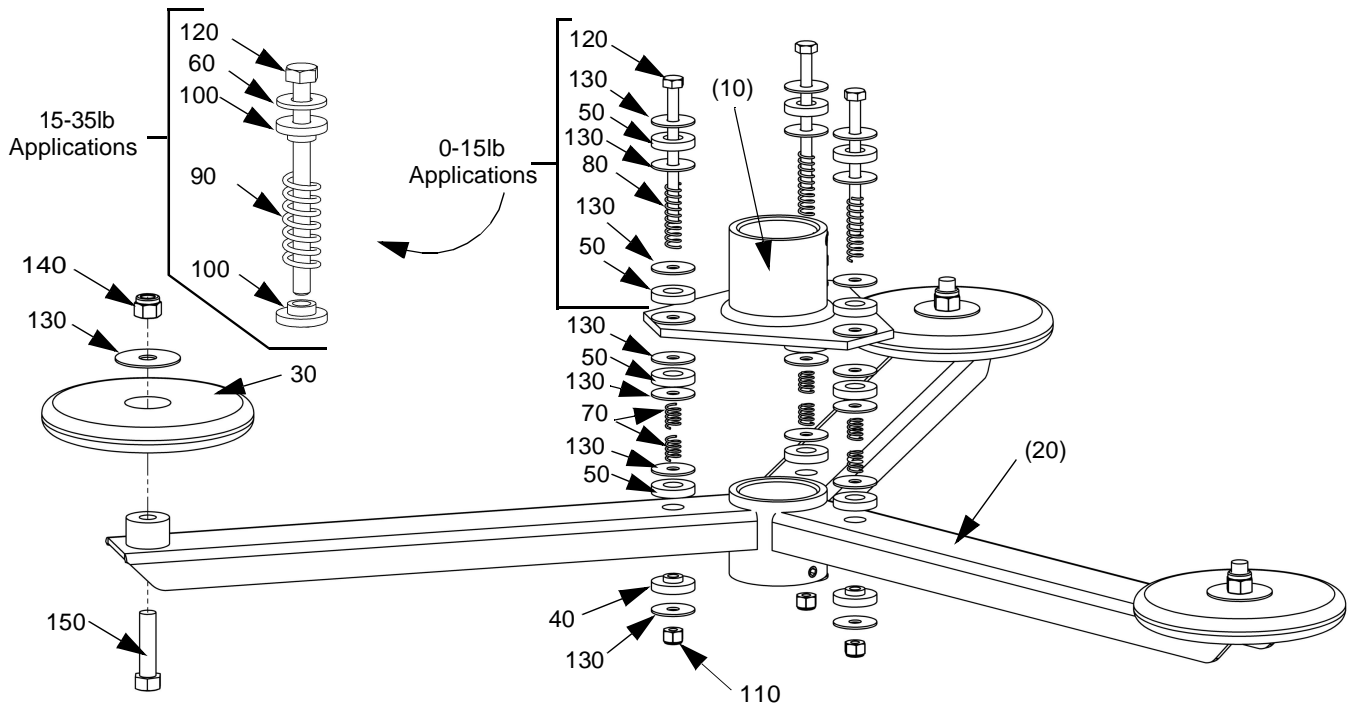

**Figure 1: CMA-347 Parts**

## INSPECT MOUNT BEFORE INSTALLATION

1. Carefully inspect the mount for shipping damage (see figure 1). If any damage is apparent, call your carrier claims agent and do not continue with the installation until the carrier has reviewed the damage.

**NOTE:** Read all assembly instructions before starting set-up or installation.

2. Carefully inspect mount components for damage.

## MOUNT INSTALLATION

The mount is shipped pre-assembled for applications under 15 pounds.

**CAUTION:** If the total combined weight of the projector, projector mount, and lower mounting pipe exceeds 15lbs, the CMA 347 vibration mount needs to be reconfigured for weights over 15lbs. Weigh all parts before beginning installation.

If the total combined weight of the projector, projector mount, and lower mounting pipe is 15lbs or below, proceed with mount installation. If the total combined weight of the projector, projector mount, and lower mounting pipe is over 15lbs, see Set-Up for Over 15 lbs on page 6.

**NOTE:** Keep the vibration mount as close as possible to the projector by minimizing the length of the lower mounting pipe.

1. Thread Upper mounting pipe (190) into Ceiling plate (180).
2. Secure NPT 1 1/2" upper mounting pipe (190) to ceiling plate (180) following the installation instructions provided with the ceiling plate (180).
3. Thread mount top (10) onto NPT 1 1/2" upper mounting pipe (190).

**NOTE:** Ensure there is no direct contact between mount and surrounding structure. Any contact could allow vibration transfer to the projector.

4. Secure NPT 1 1/2" upper mounting pipe (190) to mount top (10) using 5/16-18 x 3/8" socket head set screw (160). Turn 5/16/18 x 3/8" socket head set screw (160) until it contacts thread of NPT 1 1/2" upper mounting pipe (190).
5. Thread NPT 1 1/2" lower mounting pipe (200) into mount bottom (20).
6. Secure NPT 1 1/2" lower mounting pipe (200) to mount bottom (20) using 5/16-18 x 3/8" socket head set screw (160). Turn 5/16/18 x 3/8" socket head set screw (160) until it contacts thread of NPT 1 1/2"

lower mounting pipe (200).

7. Thread projector mount (210) onto lower NPT 1 1/2" lower mounting pipe (200).
8. Secure NPT 1 1/2" lower mounting pipe (200) to projector mount (210) following the installation instructions provided with the projector mount (210).
9. With the weight of the installation on the CMA-347, tighten the 1/4-20 x 4" tap bolts until a slight preload is on the springs.

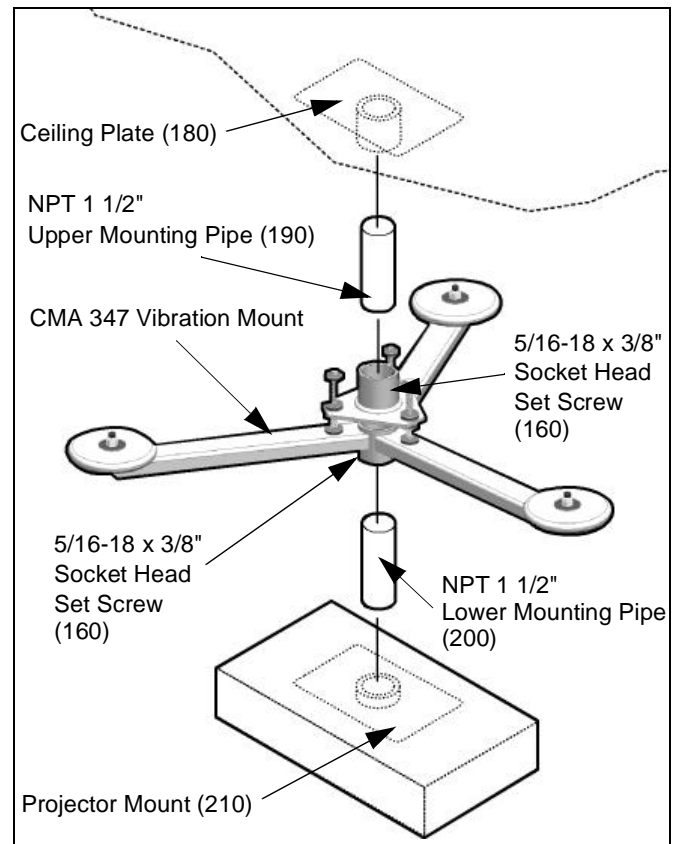

**Figure 2: CMA 347 Vibration Mount Installation**

## Set-Up

### Set-up For 15 Pounds and Under

The mount is shipped pre-assembled for applications under 15 pounds. If the total combined weight of the projector, projector mount, and lower mounting pipe is 15lbs or below, proceed with mount installation. (see MOUNT INSTALLATION on page 4)

For applications over 15 pounds, proceed to "Set-up For Over 15 Pounds".

If the mount has been previously set-up to accommodate a weight of 15-35lbs, it needs to be reconfigured to work properly with weights below 15lbs.

To set-up the mount for applications under 15lbs:

1. Un-install mount following the instructions outlined in the Removal section of this document. (see Mount Removal on page 7)
2. Loosen and remove 1/4-20 Nylock nut (110), 1/4" fender washer (130), and stepped sorbothane damper (40) located underneath mount arm and set aside for reuse. (see figure 3)
3. Slide 1/4-20 x 4" tap bolt (120) upward, out of mount top (10).

**NOTE:** Make certain hardware group B (see figure 3) and (see figure 4) stays in place when removing 1/4-20 x 4" tap bolt (120) and associated hardware.

4. Remove hardware group A (see figure 3) keeping 1/4-20 x tap bolt (120) for reuse in 0-15lb configuration.
5. Install 1/4" fender washers (130), sorbothane dampers (50), and long medium gauge spring (80), onto 1/4-20 x 4" tap bolt (120). (see figure 4)
6. Insert 1/4-20 x 4" tap bolt (120) with washers and dampers through mount top (10), group B hardware (see figure 6), and mount bottom (20). (see figure 4)
7. Install stepped sorbothane damper (40), fender washer (130), and Nylock nut (110) onto 1/4-20 x 4" tap bolt (120). (see figure 4)
8. Tighten until a slight preload is on the springs.

Repeat steps 2 through 8 for the remaining two hardware sets.

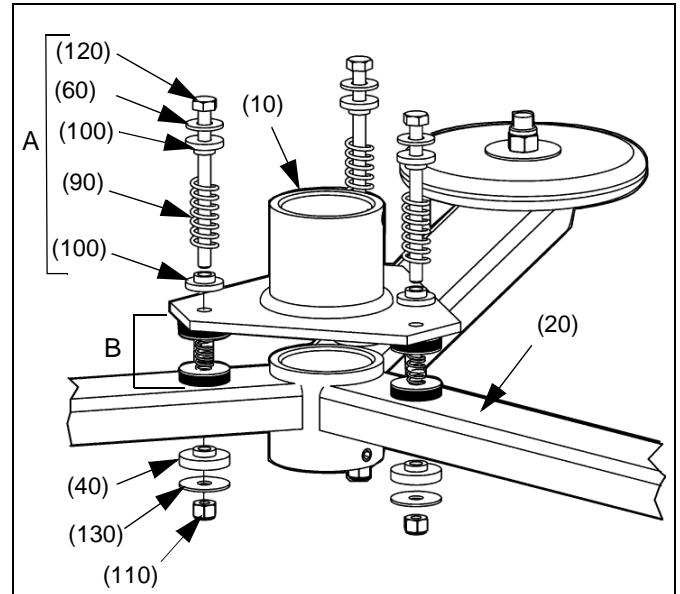

Figure 3: Remove 35lb-15lb Application Hardware.

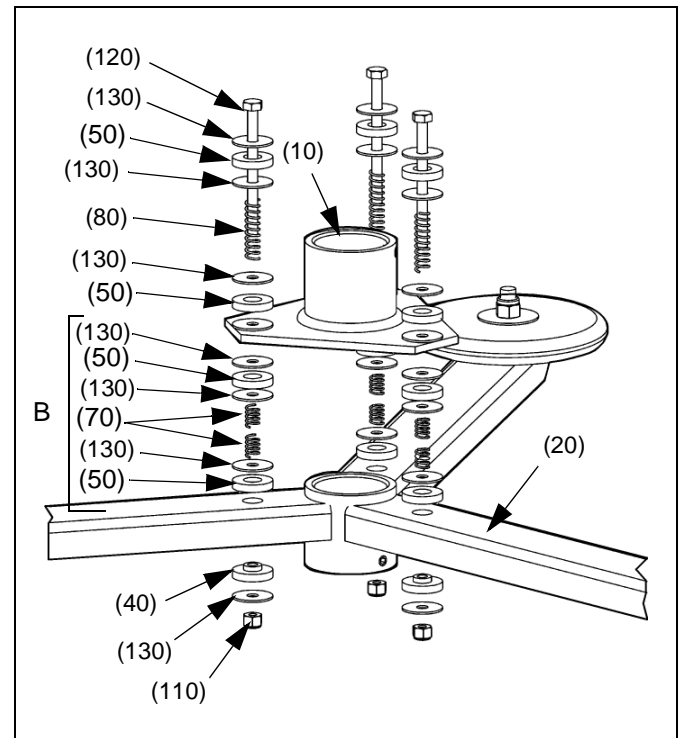

Figure 4: Install 0-15lb Application Hardware.

**Set-up For Over 15 Pounds**

The mount is shipped pre-assembled for applications under 15 pounds.

If the mount is set-up to accommodate a weight of up to 15lbs (as shipped), it needs to be reconfigured to work properly with weights over 15lbs.

**WARNING:** DO NOT attempt to reconfigure the mount while installed. Properly un-install mount and place on a flat stable surface before performing the procedure below.

To set-up the mount for applications over 15lbs:

1. Un-install mount following the instructions outlined in the Removal section of this document.
2. Loosen and remove 1/4-20 Nylock nut (110), 1/4" fender washer (130), and stepped sorbothane damper (40) located underneath mount arm and set aside for reuse. (see figure 5)
3. Slide 1/4-20 x 4" tap bolt (120) upward, out of mount top (10).

**NOTE:** Make certain hardware group B (see figure 5) stays in place when removing 1/4-20 x 4" tap bolt (120) and associated hardware.

4. Remove hardware group A (see figure 5) keeping 1/4-20 x tap bolt (120) for reuse in 15lb-35lb configuration.
5. Install 1/4" machine washer (60), stepped dampers (100), and long heavy gauge spring (90), onto 1/4-20 x 4" tap bolt (120). (see figure 6)
6. Insert 1/4-20 x 4" tap bolt (120) with washers and dampers through mount top (10), group B hardware (see figure 6), and mount bottom (20). (see figure 6)
7. Install stepped sorbothane damper (40), fender washer (130), and Nylock nut (110) onto 1/4-20 x 4" tap bolt (120).
8. Tighten all the parts installed in Step 1, Step 2 and Step 3 using a 1/4-20 x 4" tap bolt (120) and 1/4-20 Nylock nut (110) until a slight preload is on the springs.

**NOTE:** Repeat steps 2 through 8 for the remaining two hardware sets.

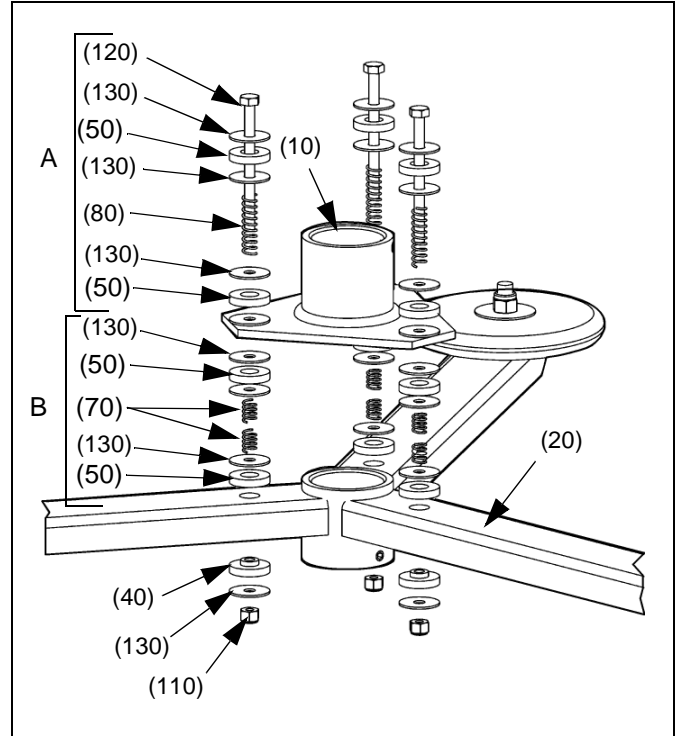

**Figure 5: Remove 0-15lb Application Hardware.**

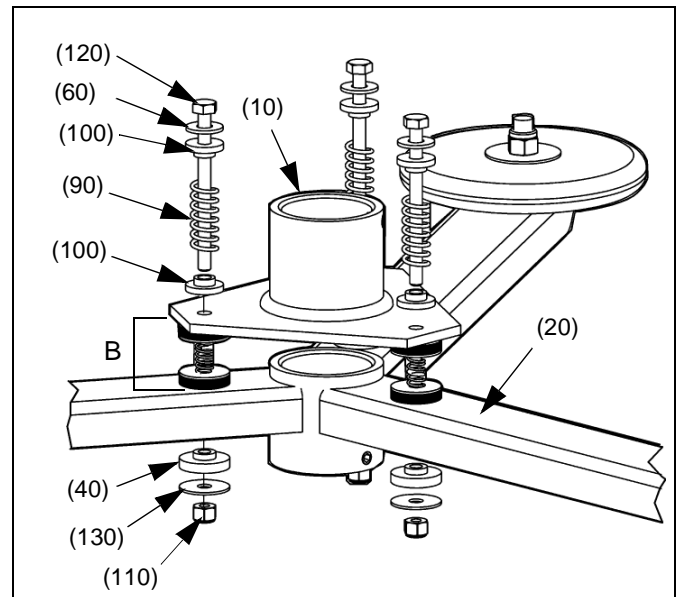
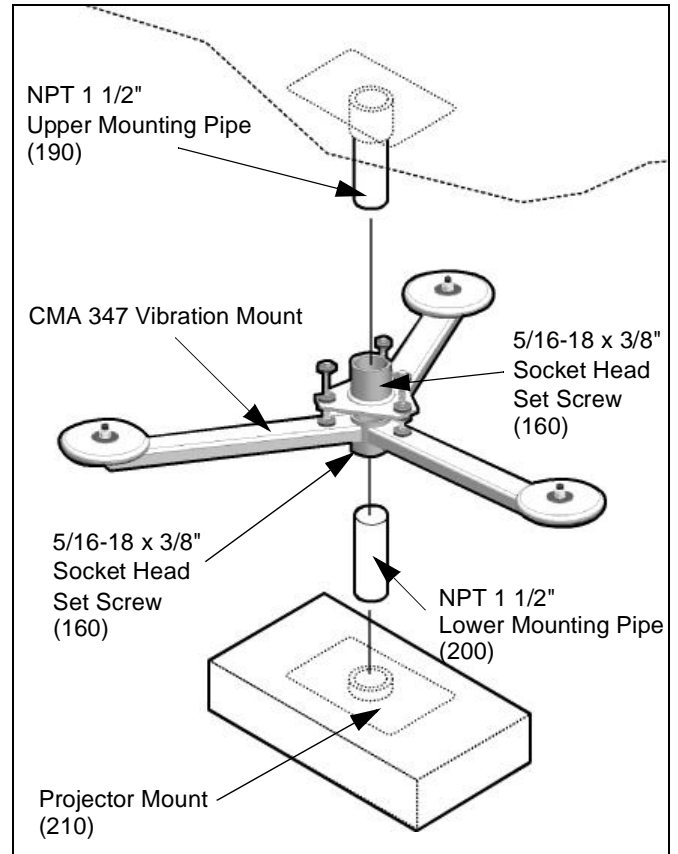

**Figure 6: Install 15lb-35lb Application Hardware.**

## Mount Removal

To remove the CMA 347 vibration mount:

1. Disconnect power cables and wires from projector.
2. Uninstall projector from projector mount (210).
3. Uninstall projector mount (210) from NPT 1 1/2" lower mounting pipe (200) following the instructions provided with the projector mount (210).
4. Loosen 5/16-18 x 3/8" socket head set screw (160) securing NPT 1 1/2" lower mounting pipe (200) to mount bottom (20).
5. Uninstall NPT 1 1/2" lower mounting pipe (200) from mount bottom (20) by turning NPT 1 1/2" lower mounting pipe (200) counterclockwise.
6. Loosen 5/16-18 x 3/8" socket head set screw (160) securing mount top (10) to NPT 1 1/2" upper mounting pipe (190).
7. Uninstall vibration mount from NPT 1 1/2" upper mounting pipe (190) by turning mount top (10) counterclockwise.



**Figure 7: CMA 347 Vibration Mount Removal**

