

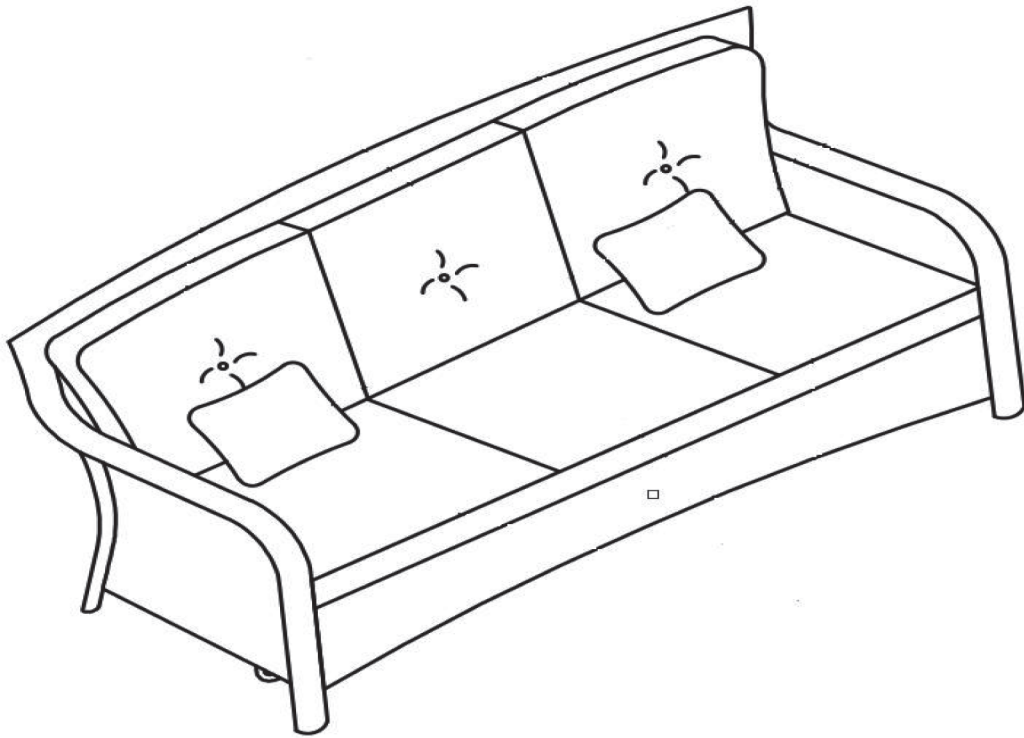





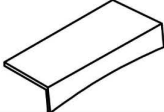
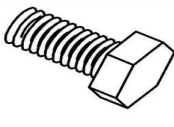

# Sofa

## Owner's Manual

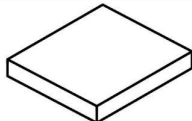
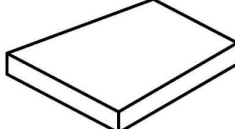

# PART LIST

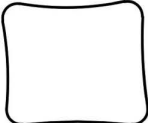
PART#	DESCRIPTION	PICTURE	Q'TY
A	Seat Frame		1
B	Seat		1
C	Bolt M6 x 20 mm		7
D	M6 Washer		7
E	M6 Bolt Cover		7
F	Open Wrench		1
G	Middle of Seat Cushion		1
H	2 Sides of Seat Cushion		2
I	Middle of Back Cushion		1
J	2 Sides of Back Cushion		2
K	Toss Pillow		2

### Assembly Steps:

**Note: Do not fully tighten bolts until assembly is completed and alignment is correct.**

Step 1. Carefully place the seat frame (A) upside down on a non-abrasive surface. (Figure 1)

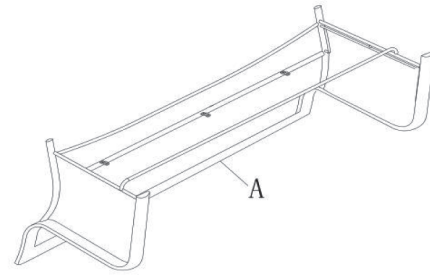

Figure 1

Step 2. With the help of another person, carefully place the seat (B) into the seat frame. Connect the seat to the seat frame with bolts (C), washers (D) by using open wrench (F), then cover the bolts with bolt covers (E) as show in Figure 2.(Figure 2&3)

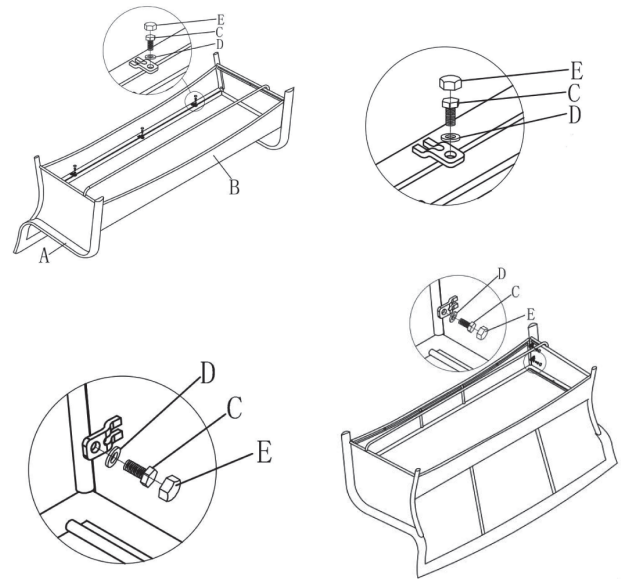

Figure 2

Step 3. Place the seat cushion (G&H), back cushion (I&J) and toss pillow (K) on the seat. Your sofa is now ready to use. (Figure 4).

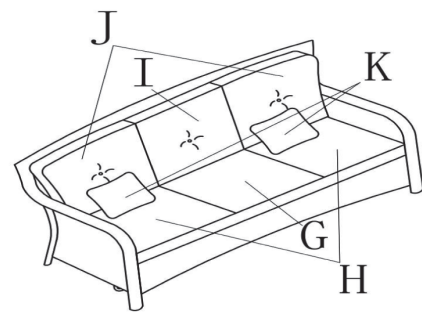
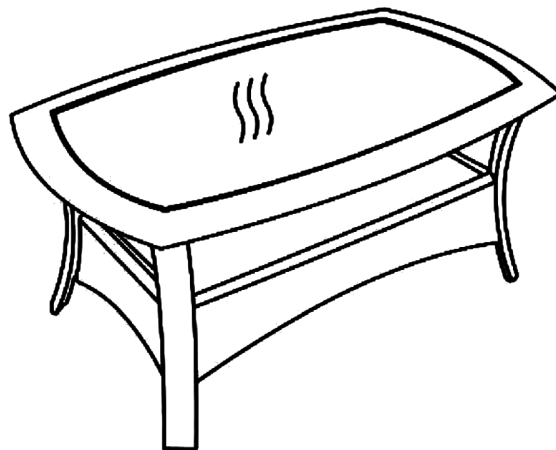

Figure 3

# Coffee Table

## Owner's Manual







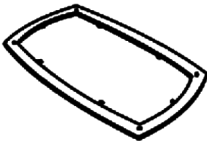

If you have any problems with this product, DO NOT RETURN IT TO  
THE STORE. CALL OUR CUSTOMER SERVICE HOT-LINE at

1-877-397-5144

8am-5pm (EST), Monday-Thursday, 8am-4pm(EST), Friday

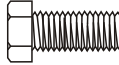
## PARTS LIST

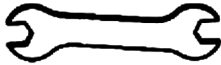
PART#	DESCRIPTION	PICTURE	Q'TY
A	Table Rim with Glass		1
B	Table Leg		4
C	Short Leg Connector		2
D	Long Leg Connector		2
E	Leg Connecting Plate		1
F	Bolt M6x15		20
G	M6 Washer		20
H	Bolt Cap		20
I	Open Wrench		2

## Assembly Steps:

**Note: Do not fully tighten bolts until assembly is completed and alignment is correct.**

Step 1. Take the glass top away from the table rim and place the glass top on a soft surface.

Step 2. Carefully place the table rim(A) upside down on a non-abrasive surface(See figure 1).

Step 3. Assemble the table legs (B) to the table rim (A) with bolts (F) and washers (G) by using open wrench(I) as shown in figure 2.

Step 4. Assemble the short leg connector (C) to the table legs (B) with bolts (F) and washers (G) by using open wrench(I) as shown in figure 3.

Step 5. Then assemble one of the long leg connector (D) to the table legs (B) with bolts (F) and washers (G) by using open wrench(I) as shown in figure 4.

Step 6. Insert the leg connecting plate(E) to the one of the long leg connector. as shown in figure 5.

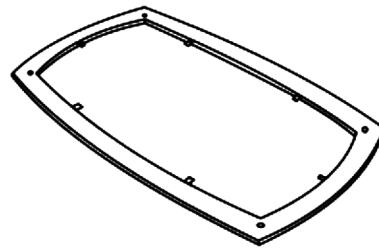

Figure 1

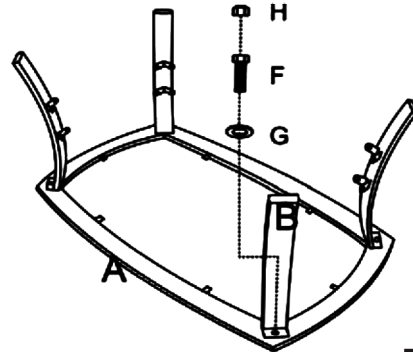

Figure 2

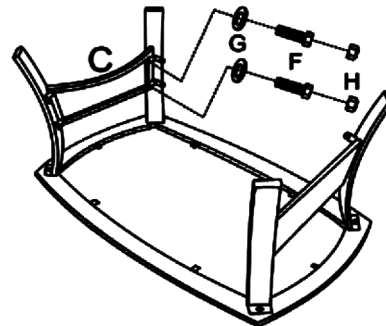

Figure 3

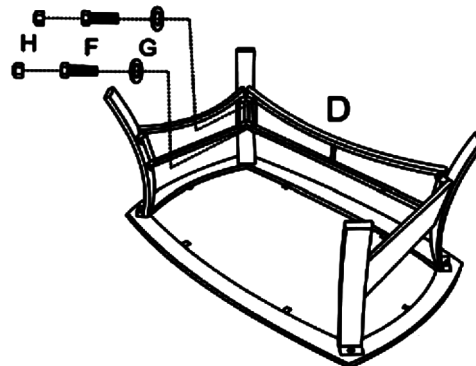

Figure 4

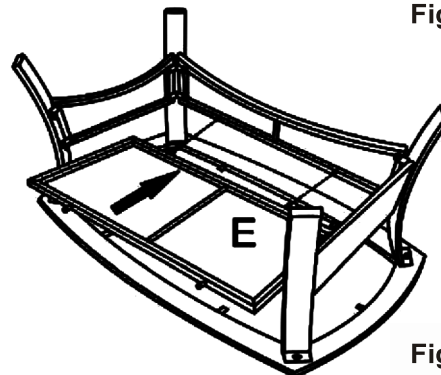

Figure 5

Step 7. Then insert the leg connecting plate to the other long leg connector(D) and at the same time assemble the long leg connector to the table legs with bolts(F) and washers(G) as shown in figure 6

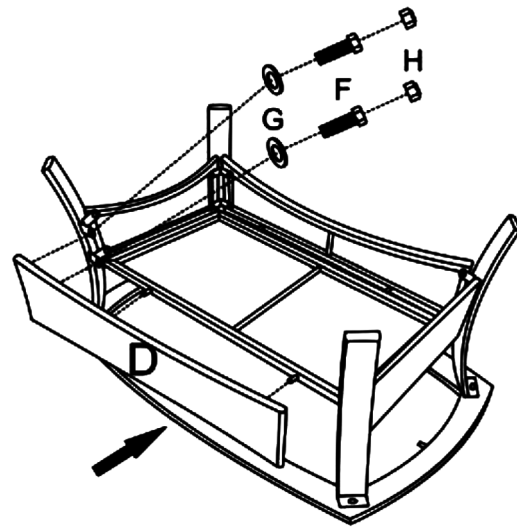

Figure 6

Step 8. Check the alignment and adjust if necessary. Once the alignment is correct, tighten all bolts with open wrench(I). Cover all bolts with bolt caps (H).

Step 9. Verify all bolts are securely tightened before use and turn your table right side up.

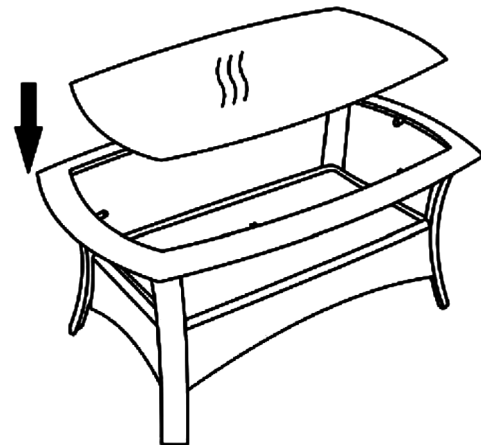

Figure 7

Step 10. Place the glass top on the table rim (See Figure7). Your table is now ready to use.

**Warning:**

**Do not crawl, stand, or sit on glass table tops.**

**Do not set or lay heavy items on glass table tops.**

**Avoid extreme hot & cold items being placed on glass table tops.**

**This glass table top is produced with tempered glass which is designed to safely shatter in small pieces when impacted or stressed beyond strength limitations.**