

MODEL PM500SS POWER PACK

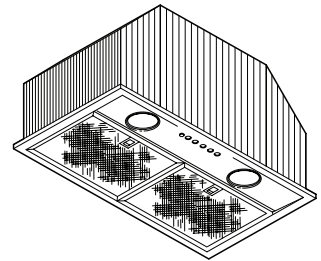

FEATURES

- Durable, 430 stainless steel with #4 brushed finish
- Non-exposed housing made with electro-galvanized steel
- Multi speed control
- Centrifugal blower, 500 CFM, 9.0 Sones
- 6" round duct connector/backdraft damper
- Accepts two halogen lamps, Type JC 12V 20W G4 Base (lamps included)
- Two washable aluminum mesh filters with quick-release latches
- Fully enclosed bottom
- One Year Limited Warranty
- Recommended for use with Models LB30, LB36, LT30, and LT36 Liners

OPTIONAL ACCESSORIES:

- Disposable charcoal filter kit (part no. 99010374)
- Non-duct kit (Model 359NDK)
- Universal make-up air damper (Models MD6TU, MD8TU, MD10TU)
- Fresh air inlet - required with universal make-up air damper (Models 641FA, 643FA, 610FA)

SPECIFICATIONS

VOLTS	AMPS	CFM	SONES	DUCT
120	2.8	500	9.0	6-in. round



TYPICAL SPECIFICATION

Power Pack shall be Broan® Model PM500SS.

Power Pack shall have a multi-speed fan switch and separate light switch.

Fan must be convertible between ducted and non-ducted discharge. Ducted mode uses a washable aluminum mesh filter. Non-ducted mode uses optional, disposable charcoal filter.

Air delivery to be at least 500 CFM and sound levels not greater than 9.0 Sones.

Unit shall be UL and cUL listed.

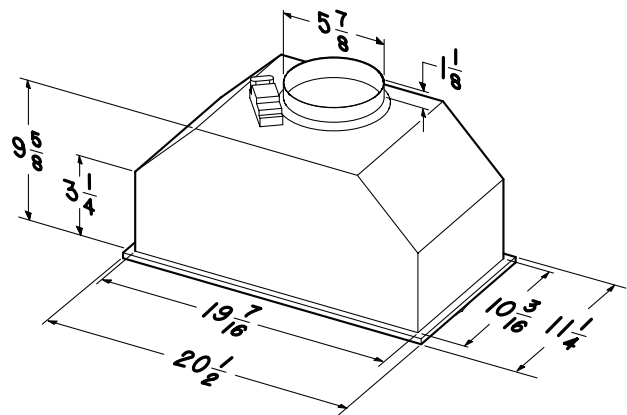

HVI-2100 CERTIFIED RATINGS comply with new testing technologies and procedures prescribed by the Home Ventilating Institute, for off-the-shelf products, as they are available to consumers. Product performance is rated at 0.1 in. static pressure, based on tests conducted in a state-of-the-art test laboratory. Sones are a measure of humanly-perceived loudness, based on laboratory measurements.

Broan-NuTone LLC Hartford, Wisconsin www.broan.com 800-558-1711
Broan-NuTone Canada Mississauga, Ontario www.broan.ca 877-896-1119

REFERENCE	QTY.	REMARKS	Project
			Location
			Architect
			Engineer
			Contractor
			Submitted by Date