

TLD+ lens 90° Short Throw (0.65-0.85:1)

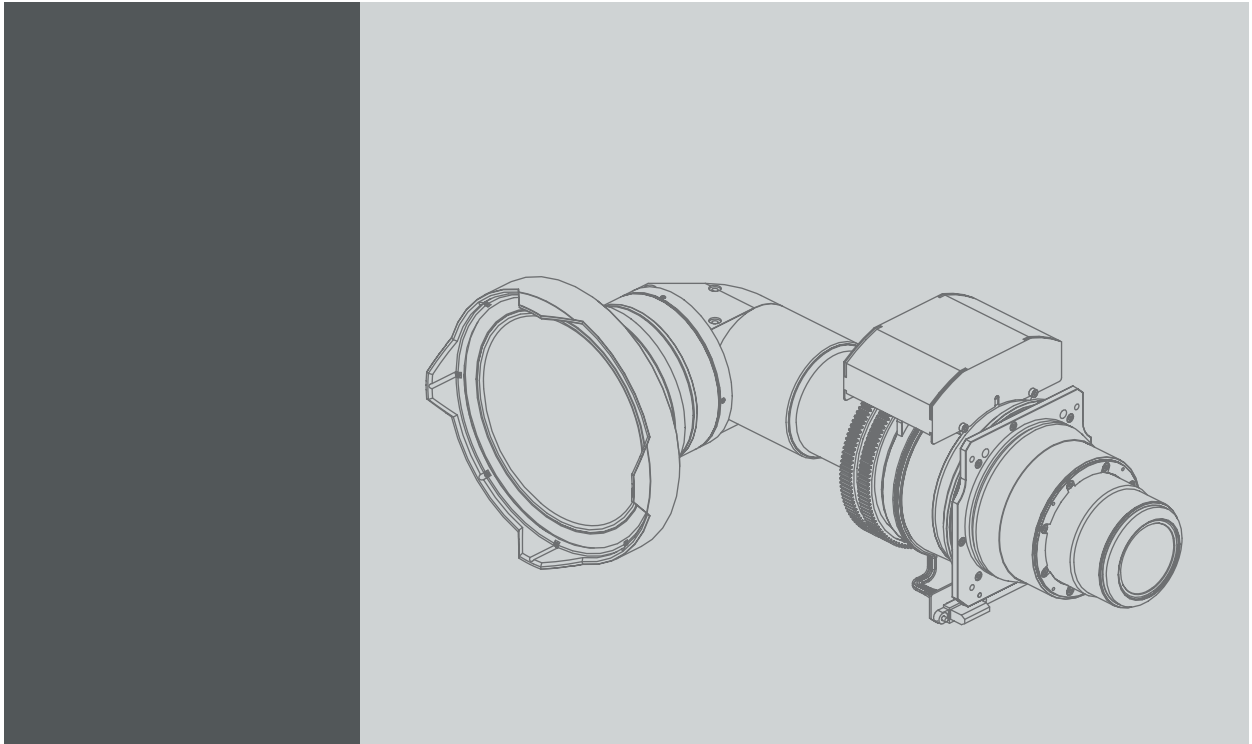

Installation manual

R9862001

Barco NV

Beneluxpark 21, 8500 Kortrijk, Belgium

Phone: +32 56.23.32.11

Fax: +32 56.26.22.62

Support: www.barco.com/en/support

Visit us at the web: www.barco.com

Registered address: Barco NV

President Kennedypark 35, 8500 Kortrijk, Belgium

Phone: +32 56.23.32.11

Fax: +32 56.26.22.62

Support: www.barco.com/en/support

Visit us at the web: www.barco.com

Copyright ©

All rights reserved. No part of this document may be copied, reproduced or translated. It shall not otherwise be recorded, transmitted or stored in a retrieval system without the prior written consent of Barco.

Changes

Barco provides this manual 'as is' without warranty of any kind, either expressed or implied, including but not limited to the implied warranties or merchantability and fitness for a particular purpose. Barco may make improvements and/or changes to the product(s) and/or the program(s) described in this publication at any time without notice.

This publication could contain technical inaccuracies or typographical errors. Changes are periodically made to the information in this publication; these changes are incorporated in new editions of this publication.

The latest edition of Barco manuals can be downloaded from the Barco web site www.barco.com or from the secured Barco web site <https://www.barco.com/en/signin>.

Disposal Information

Waste Electrical and Electronic Equipment



■ This symbol on the product indicates that, under the European Directive 2012/19/EU governing waste from electrical and electronic equipment, this product must not be disposed of with other municipal waste. Please dispose of your waste equipment by handing it over to a designated collection point for the recycling of waste electrical and electronic equipment. To prevent possible harm to the environment or human health from uncontrolled waste disposal, please separate these items from other types of waste and recycle them responsibly to promote the sustainable reuse of material resources.

For more information about recycling of this product, please contact your local city office or your municipal waste disposal service.

For details, please visit the Barco website at: <http://www.barco.com/en/AboutBarco/weee>

Guarantee and Compensation

Barco provides a guarantee relating to perfect manufacturing as part of the legally stipulated terms of guarantee. On receipt, the purchaser must immediately inspect all delivered goods for damage incurred during transport, as well as for material and manufacturing faults Barco must be informed immediately in writing of any complaints.

The period of guarantee begins on the date of transfer of risks, in the case of special systems and software on the date of commissioning, at latest 30 days after the transfer of risks. In the event of justified notice of complaint, Barco can repair the fault or provide a replacement at its own discretion within an appropriate period. If this measure proves to be impossible or unsuccessful, the purchaser can demand a reduction in the purchase price or cancellation of the contract. All other claims, in particular those relating to compensation for direct or indirect damage, and also damage attributed to the operation of software as well as to other services provided by Barco, being a component of the system or independent service, will be deemed invalid provided the damage is not proven to be attributed to the absence of properties guaranteed in writing or due to the intent or gross negligence or part of Barco.

If the purchaser or a third party carries out modifications or repairs on goods delivered by Barco, or if the goods are handled incorrectly, in particular if the systems are operated incorrectly or if, after the transfer of risks, the goods are subject to influences not agreed upon in the contract, all guarantee claims of the purchaser will be rendered invalid. Not included in the guarantee coverage are system failures which are attributed to programs or special electronic circuitry provided by the purchaser, e.g. interfaces. Normal wear as well as normal maintenance are not subject to the guarantee provided by Barco either.

The environmental conditions as well as the servicing and maintenance regulations specified in this manual must be complied with by the customer.

Trademarks

Brand and product names mentioned in this manual may be trademarks, registered trademarks or copyrights of their respective holders. All brand and product names mentioned in this manual serve as comments or examples and are not to be understood as advertising for the products or their manufacturers.

1. TLD+ ZOOM LENS 90° SHORT THROW

About this document

Read this document attentively. It contains important information on how to correctly install and adjust the Short Throw 90° zoom lens. The latest edition of this document can be downloaded from the Barco website: www.barco.com/td/R9862001.



Because this 90 degrees lens makes use of an intermediate image in the optics of the lens, Top becomes Bottom. For that the projector orientation settings have to be adapted accordingly: Ceiling Mount becomes Table Mount and Front Projection becomes Rear Projection. See user manual of the projector to modify the projector orientation.

Overview

- Introduction
- Install the Short Throw zoom lens on an UDX projector
- Install the Short Throw zoom lens on a HDX/HDF projector
- Adjustment of the Short Throw zoom lens
- Change the motor block orientation

1.1 Introduction

About the TLD+ 90° Short Throw Zoom Lens (0.65-0.85:1)

This lens is exclusively designed to be used on the Barco projector series UDX, HDX and HDF. The lens output is 90° turned. This allows an optimal use of the vertical shift range when projecting to the left seen from the rear side of the projector.

This lens is designed for ultra short throw video performance.

Lens shift +/-150%, depending on projector type, please use the Barco Lens calculator to calculate actual values.

Different motor block orientations

The HDX and HDF projector series have an different lens holder than the UDX series: the socket for the electrical connection has another orientation between these two types of lens holders.

For that the lens is designed with a motor block that easily can be rotated around the lens body. This allows that the lens output direction remains the same while the electrical plug on the motor block can be turned to matches the electrical plug on the lens holder front plate. See example illustration below.

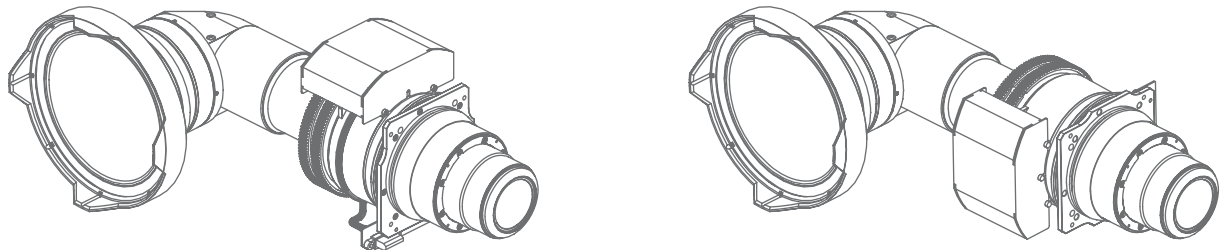

Image 1-1

For UDX series the motor block must always be located above the lens body (ref. 1) when facing the projector from the front side in table mount. For HDX/HDF series the motor block must always be located at the right side (ref. 2) of the lens body when facing the projector from the front side in table mount.

1. TLD+ zoom lens 90° Short Throw



Image 1-2

The lens body can be rotated per 90° relative to the motor block. However, the most common configuration is probably with the lens output oriented to the left seen from the rear side of the projector in table mount. Other directions (e.g. downwards) may cause interference of the projector housing/rigging frame in the light path of the projected image.

The Short Throw 90° zoom lens is delivered with the motor block mounted in the orientation for left projection of the UDX series in table mount. To change the motor block orientation see procedure "Change the motor block orientation", page 5 .

1.2 Install the Short Throw zoom lens on an UDX projector

How to install the Short Throw zoom lens on an UDX projector

1. Place the primary lens lock in "unlock" position. Handle (ref. 1) towards electrical socket (ref. 4).
2. Check if the secondary lens lock stands in the "unlock" position (ref. 2)
3. Check if the motor block (ref. 3) of the lens is oriented for UDX projectors. If not, see procedure , to adapt the orientation.
4. Check if the set screw (ref. 5) in the lower left corner of the mounting plate on the lens is inserted. The set screw should exceed 1.5 mm.

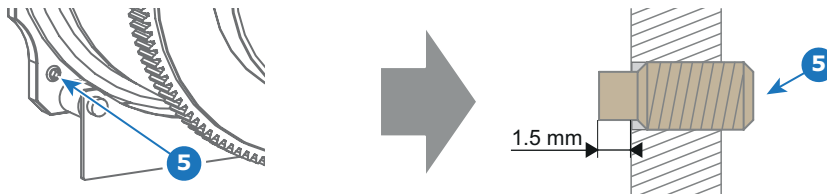

Image 1-3

5. Gently insert the lens. Ensure the lens connector matches the electrical socket on the lens holder.
6. Insert the lens until the connector seats into the socket.

Note: The secondary lens lock (ref. 2) makes an audible clicking sound when latching.

Caution: Do not release the lens yet, keep pushing the lens against the front plate!

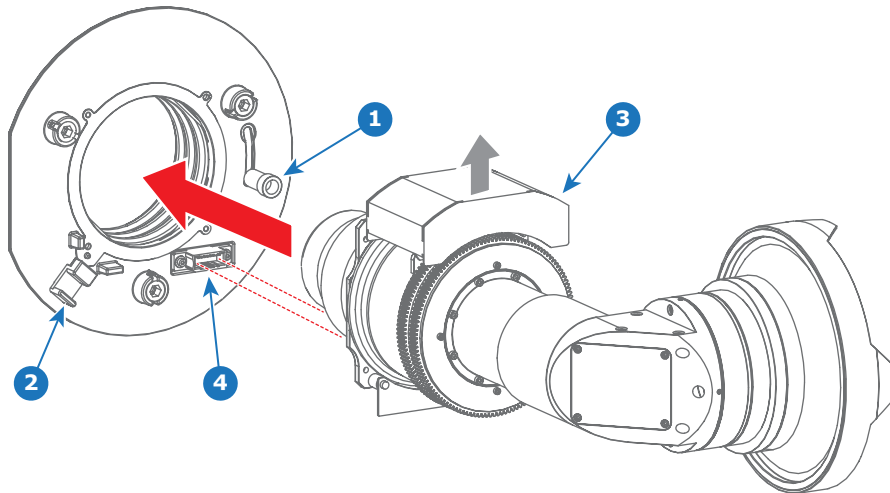

Image 1-4

7. Secure the lens in the lens holder by sliding the primary lens lock handle into the “locked” position.
8. Check if the lens touches the front plate of the Lens Holder.
9. Check if the lens is really secured by trying to pull the lens out of the lens holder.

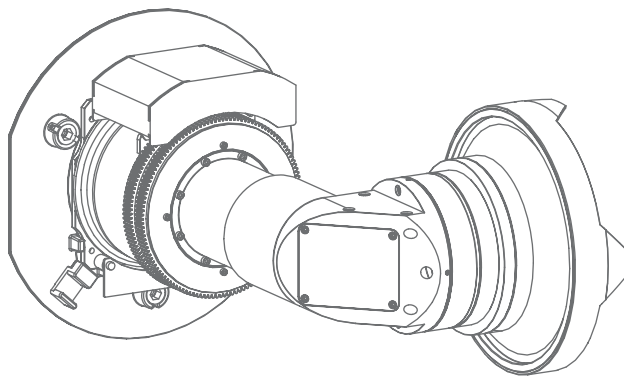

Image 1-5



After installation the lens needs to be adjusted. See procedure "Adjustment of the Short Throw zoom lens", page 5 .

1.3 Install the Short Throw zoom lens on a HDX/HDF projector

How to install the lens on a HDX/HDF projector

1. Place the lens lock in “unlock” position. Handle (ref. 1) towards electrical socket (ref. 4).
2. Check if the motor block (ref. 3) of the lens is oriented for HDX/HDF projectors. If not, see procedure "Change the motor block orientation", page 5 , to adapt the orientation.
3. Check if the set screw (ref. 5) in the lower left corner of the mounting plate on the lens does not exceed the mounting plate.

1. TLD+ zoom lens 90° Short Throw

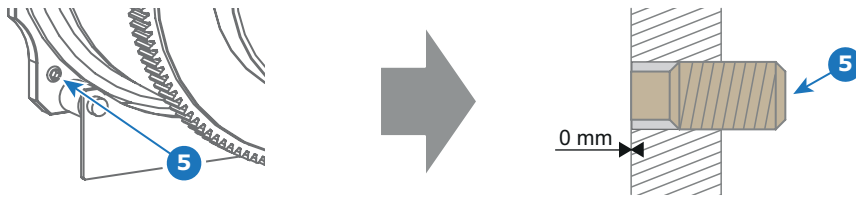

Image 1-6

4. Gently insert the lens. Ensure the lens connector matches the electrical socket on the lens holder.
5. Insert the lens until the connector seats into the socket.

Caution: Do not release the lens yet, keep pushing the lens against the front plate!

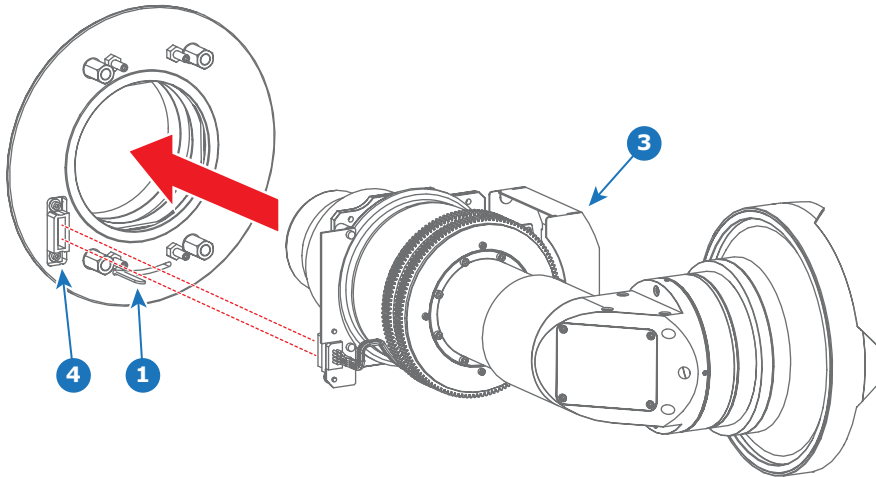

Image 1-7

6. Secure the lens in the lens holder by sliding the lens lock handle into the "locked" position.
7. Check if the lens touches the front plate of the Lens Holder.
8. Check if the lens is really secured by trying to pull the lens out of the lens holder.

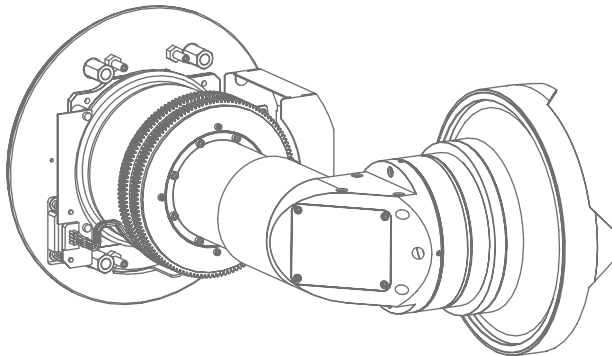

Image 1-8

9. Install the lens safety cable. Keep safety cable as short as possible. See user manual of the projector for detailed instructions.



After installation the lens needs to be adjusted. See procedure "Adjustment of the Short Throw zoom lens", page 5 .

1.4 Adjustment of the Short Throw zoom lens



Because this 90 degrees lens makes use of an intermediate image in the optics of the lens, Top becomes Bottom. For that the projector orientation settings have to be adapted accordingly: Ceiling Mount becomes Table Mount and Front Projection becomes Rear Projection. See user manual of the projector to modify the projector orientation.

How to adjust the lens

1. Start up the projector and project the focus pattern on the screen. See user manual of the projector for detailed instructions.
2. Rotate the "adjusting ring for various throw distance" (Ring-A) to the position of the throw distance you need.
If your throw distance is 3.4 m, the mark should be located between 3 m and 4 m. (as shown in image 1-9)
Note: Ring-A is not motorized. Manual adjustment is needed.
3. Rotate "the focusing gear" (Ring-B) to get good focus of CENTER.
Note: Ring-B is motorized. Use the remote control or local keypad of the projector to adjust.

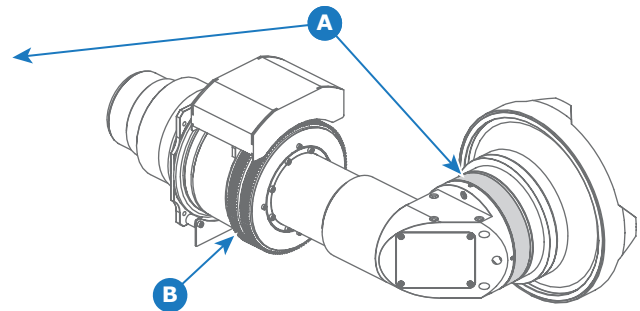
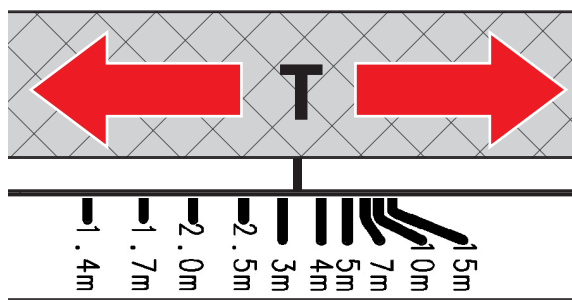

Image 1-9

- A Adjustment Ring-A : various throw distance
B Adjustment Ring-B : focusing gear
T Throw distance (projection distance)

4. If NOT getting good focus of both CENTER and CORNERS, rotate the Ring-A in the direction of getting better focus of CORNERS.
5. Rotate the Ring-B again to get good focus of CENTER.
6. Repeat from step 4 until both CENTER and CORNERS have good focus.

1.5 Change the motor block orientation



The illustrations in this procedure shows a motor block rotation from UDX left side projection to HDX/HDF left side projection (seen from the rear side of the projector in table mount)

Necessary tools

Allen wrench 2.5mm.

Necessary parts

Set screw M5x8 DIN915.

1. TLD+ zoom lens 90° Short Throw

Rotate the motor block of the lens

1. Remove the eight screws (reference 1) as illustrated. Use a 2.5mm Allen wrench

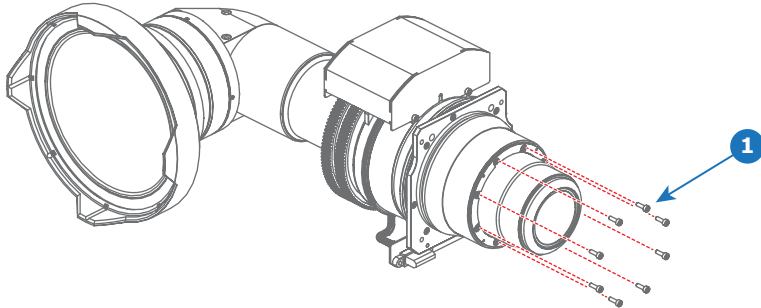

Image 1-10

2. Rotate the motor block around the lens body in to the desired position.

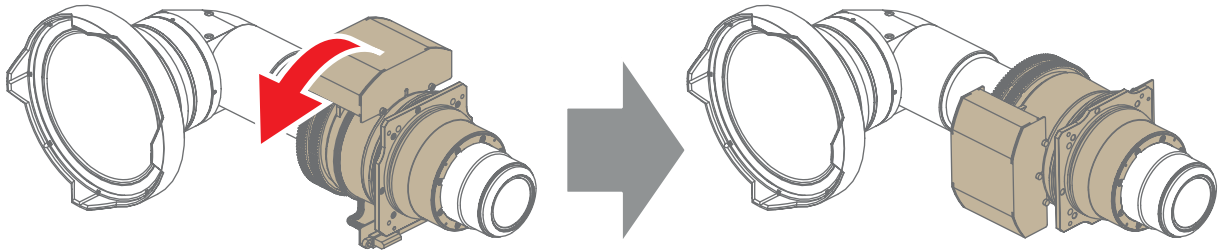

Image 1-11

3. Fasten the motor block with the eight screws which you have removed in step 1.

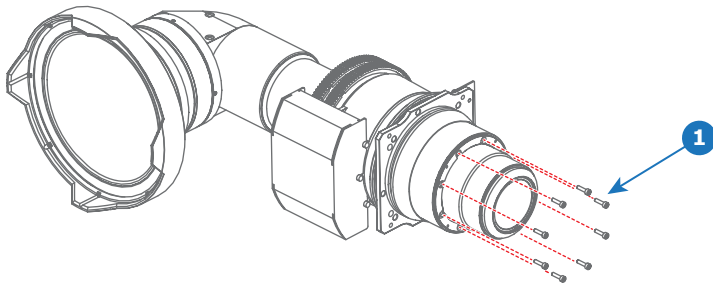

Image 1-12

4. Will the lens be installed on an UDX projector?

If yes, turn the set screw into the mounting plate until it exceeds 1.5 mm on the other side of the mounting plate.

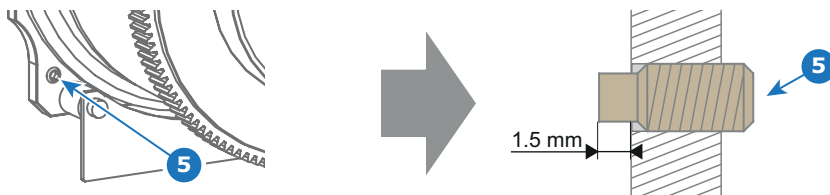

Image 1-13

If no, turn the set screw out of the mounting plate until it doesn't exceed on the other side of the mounting plate.

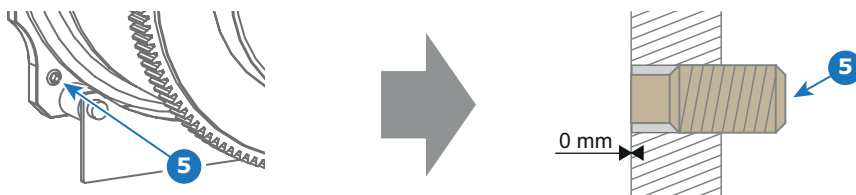

Image 1-14