

# G100



## Installation manual

**Barco NV**

Beneluxpark 21, 8500 Kortrijk, Belgium  
[www.barco.com/en/support](http://www.barco.com/en/support)  
[www.barco.com](http://www.barco.com)

**Registered office: Barco NV**

President Kennedypark 35, 8500 Kortrijk, Belgium  
[www.barco.com/en/support](http://www.barco.com/en/support)  
[www.barco.com](http://www.barco.com)



## Copyright ©

All rights reserved. No part of this document may be copied, reproduced or translated. It shall not otherwise be recorded, transmitted or stored in a retrieval system without the prior written consent of Barco.

## Changes

Barco provides this manual 'as is' without warranty of any kind, either expressed or implied, including but not limited to the implied warranties or merchantability and fitness for a particular purpose. Barco may make improvements and/or changes to the product(s) and/or the program(s) described in this publication at any time without notice.

This publication could contain technical inaccuracies or typographical errors. Changes are periodically made to the information in this publication; these changes are incorporated in new editions of this publication.

The latest edition of Barco manuals can be downloaded from the Barco web site [www.barco.com](http://www.barco.com) or from the secured Barco web site <https://www.barco.com/en/signin>.

## Trademarks

Brand and product names mentioned in this manual may be trademarks, registered trademarks or copyrights of their respective holders. All brand and product names mentioned in this manual serve as comments or examples and are not to be understood as advertising for the products or their manufacturers.

## Guarantee and Compensation

Barco provides a guarantee relating to perfect manufacturing as part of the legally stipulated terms of guarantee. On receipt, the purchaser must immediately inspect all delivered goods for damage incurred during transport, as well as for material and manufacturing faults. Barco must be informed immediately in writing of any complaints.

The period of guarantee begins on the date of transfer of risks, in the case of special systems and software on the date of commissioning, at latest 30 days after the transfer of risks. In the event of justified notice of complaint, Barco can repair the fault or provide a replacement at its own discretion within an appropriate period. If this measure proves to be impossible or unsuccessful, the purchaser can demand a reduction in the purchase price or cancellation of the contract. All other claims, in particular those relating to compensation for direct or indirect damage, and also damage attributed to the operation of software as well as to other services provided by Barco, being a component of the system or independent service, will be deemed invalid provided the damage is not proven to be attributed to the absence of properties guaranteed in writing or due to the intent or gross negligence or part of Barco.

If the purchaser or a third party carries out modifications or repairs on goods delivered by Barco, or if the goods are handled incorrectly, in particular if the systems are operated incorrectly or if, after the transfer of risks, the goods are subject to influences not agreed upon in the contract, all guarantee claims of the purchaser will be rendered invalid. Not included in the guarantee coverage are system failures which are attributed to programs or special electronic circuitry provided by the purchaser, e.g. interfaces. Normal wear as well as normal maintenance are not subject to the guarantee provided by Barco either.

The environmental conditions as well as the servicing and maintenance regulations specified in this manual must be complied with by the customer.



# Table of contents

<b>1</b>	<b>Safety</b>	<b>7</b>
1.1	General considerations	8
1.2	Important safety instructions	10
1.3	Product safety labels	14
1.4	Risk Group 3 Safety	15
1.4.1	General considerations	15
1.4.2	High Brightness precautions: Hazard Distance	15
1.4.3	HD for fully enclosed projection systems	17
1.5	Regulatory	19
<b>2</b>	<b>Prepare to install</b>	<b>21</b>
2.1	Installation requirements	22
2.2	Initial inspection	24
2.3	Getting to know the projector	25
2.4	Input/Output (I/O) Panel	28
2.5	Control panel	29
2.6	Overview of the RCU	30
2.7	Adjusting the projector's position	31
2.8	Lens selection	32
2.9	Lenses	33
2.10	Adjusting the image position on the screen	36
2.11	Download Projector Toolset	38
<b>3</b>	<b>Installation procedures</b>	<b>39</b>
3.1	RCU battery installation	40
3.2	Connecting the projector with the power net	41
3.3	Installing the lens	42
3.4	Installing the lens safety cable	43
3.5	Boresight (Scheimpflug) adjustment	47
3.6	Projector Address (ID)	52
3.7	Using the RCU	53
3.8	Software update	54
<b>4</b>	<b>UST lens</b>	<b>57</b>
4.1	About the UST lens	58
4.2	Parts indication	60

4.3	Adapting the lens for the projecting position.....	61
4.4	Mounting the lens adapter .....	63
4.5	When mounting the lens without the support .....	65
4.6	Mounting the UST lens .....	66
4.7	Lens adjustment .....	70
<b>5</b>	<b>Powering on/off the projector .....</b>	<b>73</b>
5.1	Powering on the projector .....	74
5.2	Powering off the projector .....	75
<b>A</b>	<b>Dimensional drawings.....</b>	<b>77</b>
A.1	Dimensions of the projector .....	78
A.2	Ceiling mount information .....	79
	<b>Index .....</b>	<b>81</b>

# Safety

# 1

1.1	General considerations .....	8
1.2	Important safety instructions .....	10
1.3	Product safety labels.....	14
1.4	Risk Group 3 Safety.....	15
1.5	Regulatory .....	19

## About this document

Read this document attentively. It contains important information to prevent personal injury while installing and using the G100 projector. Furthermore, it includes several cautions to prevent damage to the G100 projector. Ensure that you understand and follow all safety guidelines, safety instructions and warnings mentioned in this chapter before installing the G100 projector.

## Clarification of the term “G100” used in this document

When referring in this document to the term “G100” means that the content is applicable for following Barco products:

- G100-W16, G100-W19, G100-W22

## Model certification name

- G100



Barco provides a guarantee relating to perfect manufacturing as part of the legally stipulated terms of guarantee. Observing the specification mentioned in this chapter is critical for projector performance. Neglecting this can result in loss of warranty.

# 1.1 General considerations

## General safety instructions

- Before operating this equipment please read this manual thoroughly and retain it for future reference.
- Installation and preliminary adjustments should be performed by qualified Barco personnel or by authorized Barco service dealers.
- All warnings on the projector and in the documentation manuals should be adhered to.
- All instructions for operating and use of this equipment must be followed precisely.
- All local installation codes should be adhered to.
- IEC/EN 60825-1: 2014 Laser class 1 RG2 or RG3.
- IEC/EN 62471-5:2015 RG2 or RG3.
- Additional instructions to supervise children, no staring, and not use optical aids.
- Additional instructions to install above the reach of children.
- Notice is given to supervise children and to never allow them to stare into the projector beam at any distance from the projector.
- Notice is given to use caution when using the remote control for starting the projector while in front of the projection lens.
- Notice is given to the user to avoid the use of optical aids such as binoculars or telescopes inside the beam.
- “As with any bright light source, do not stare into the beam, RG2 IEC 62471-5:2015”.
- “WARNING: MOUNT ABOVE THE HEADS OF CHILDREN. The use of a ceiling mount is recommended with this product to place it above the eyes of children.

## Notice on safety

This equipment is built in accordance with the requirements of the applicable international safety standards. These safety standards impose important requirements on the use of safety critical components, materials and insulation, in order to protect the user or operator against risk of electric shock and energy hazard and having access to live parts. Safety standards also impose limits to the internal and external temperature rises, radiation levels, mechanical stability and strength, enclosure construction and protection against the risk of fire. Simulated single fault condition testing ensures the safety of the equipment to the user even when the equipment's normal operation fails.

## Laser safety precautions for G100 Series

This product is classified as CLASS 1 LASER PRODUCT - RISK GROUP 2 of IEC 60825-1 : 2014 and also complies with 21 CFR 1040.10 and 1040.11 except for conformance as a Risk Group 2 LIP as defined in IEC 62471-5:Ed. 1.0. For more information, see Laser Notice No. 57, dated May 8, 2019.

When installed with G LENS (2.0 - 4.0 : 1), G LENS (4.0-7.2 : 1) and G LENS (7.0 - 10.8 : 1) lens (throw ratio greater than 2.0), this projector may become Class 1 Laser Product-Risk Group 3 (RG3) according to IEC 60825-1:2014, IEC 62471-5: 2015, and also make a variance approvals under 21 CFR 1010.4 for RG3 LIP according to Classification and Requirements for Laser Illuminated Projectors (LIPs) (Laser Notice No. 57).

To ensure safety operation, read all laser safety precautions before installing and operating the projector.

- This projector uses extremely high brightness laser. Do not stare into the direct light beam, as the extremely high brightness may cause permanent eye damage. (Risk Group 2 of IEC 62471-5:2015).
- No direct exposure to the beam shall be permitted. (Risk Group 3 of IEC 62471-5:2015).
- This product is not for household use.
- Possibly hazardous optical radiation emitted from this product.
- This projector has a built-in Class 4 laser module. Never attempt to disassemble or modify the laser module.
- Any operation or adjustment not specifically instructed in the User manual creates the risk of hazardous laser radiation exposure.
- Do not stare into beam when the projector is on. When turning on the projector, make sure no one within projection range is looking into the lens.
- Follow the control, adjustment, or operation procedures to avoid damage or injury from exposure of laser radiation.

- The instructions for the assembly, operation, and maintenance include clear warnings concerning precautions to avoid possible exposure to hazardous laser radiation.

## Light Intensity Hazard Distance for G100 Series

This projector may become Laser Product-Risk Group 3 (RG3) when installed with lens with throw ratio greater than 2.0. Permanent eye injury is possible when exposed to the high intensity light beam within the hazard distance (HD).

Lens information with resolution WUXGA (0.96”):

		Hazard Distance (HD)	
Projection Lens Throw ratio	Risk Group	G100-W22	G100-W16, G100-W19
0.38 - 2.0	RG2	NA	NA
2.0 - 4.0	RG3	1940 mm	1165 mm
4.0 - 7.2	RG3	4565 mm	4120 mm
7.2 - 10.8	RG3	6400 mm	6400 mm

Follow the precautions to avoid light intensity hazard.

- NEVER look into the lens! High intensity light beam.
- Permanent eye injury is possible when exposed to the high intensity light beam within the hazard distance.
- Operators shall control access to the light beam within the hazard distance or install the product at a height that will prevent eye exposure within the hazard distance.
- Do not place any reflective objects in the light path of the projector.

## User definition

Throughout this manual, the term SERVICE PERSONNEL refers to Barco authorized persons having appropriate technical training and experience necessary to be knowledgeable of potential hazards to which they are exposed (including, but not limited to HIGH VOLTAGE ELECTRIC and ELECTRONIC CIRCUITRY and HIGH BRIGHTNESS PROJECTORS) in performing a task, and of measures to minimize the potential risk to themselves or other persons. Only Barco authorized SERVICE PERSONNEL, knowledgeable of such risks, are allowed to perform service functions inside the product enclosure. The term USER and OPERATOR refers to any person other than SERVICE PERSONNEL. When installing an interchangeable lens with a throw ratio that make the projector become RG3, refer to chapter “Risk Group 3 Safety”, page 9. Such combination of projector and lens are intended for professional use only, and are not intended for consumer use.

FOR PROFESSIONAL USE ONLY means installation can only be carried out by Barco AUTHORIZED PERSONNEL familiar with potential hazards associated with high intensity light beams.

## 1.2 Important safety instructions

### To prevent the risk of electrical shock

- This product should be operated from a mono phase AC power source.
- This apparatus must be grounded (earthed) via the supplied 3 conductor AC power cable. If none of the supplied power cables are the correct one, consult your dealer. If you are unable to insert the plug into the outlet, contact your electrician to replace your obsolete outlet. Do not defeat the purpose of the grounding-type plug.
- Do not allow anything to rest on the power cord. Do not locate this product where persons will walk on the cord. To disconnect the cord, pull it out by the plug. Never pull the cord itself.
- Use only the power cord supplied with your device. While appearing to be similar, other power cords have not been safety tested at the factory and may not be used to power the device. For a replacement power cord, contact your dealer.
- Do not operate the projector with a damaged cord. Replace the cord.
- Do not operate the projector if the projector has been dropped or damaged until it has been examined and approved for operation by a qualified service technician. Position the cord so that it will not be tripped over, pulled, or contact hot surfaces.
- If an extension cord is necessary, a cord with a current rating at least equal to that of the projector should be used. A cord rated for less amperage than the projector may overheat.
- Never push objects of any kind into this product through cabinet slots as they may touch dangerous voltage points or short out parts that could result in a risk of fire or electrical shock.
- Do not expose this projector to rain or moisture.
- Do not immerse or expose this projector in water or other liquids.
- Do not spill liquid of any kind on this projector.
- Should any liquid or solid object fall into the cabinet, unplug the set and have it checked by qualified service personnel before resuming operations.
- Do not disassemble this projector, always take it to an authorized trained service person when service or repair work is required.
- Do not use an accessory attachment which is not recommended by the manufacturer.
- Lightning - For added protection for this video product during a lightning storm, or when it is left unattended and unused for long periods of time, unplug it from the wall outlet. This will prevent damage to the device due to lightning and AC power-line surges.

### To prevent personal injury

- To prevent injury and physical damage, always read this manual and all labels on the system before connecting to the wall outlet or adjusting the projector.
- To prevent injury, take note of the weight of the projector.
- To prevent injury, ensure that the lens and all covers are correctly installed. See installation procedures.
- Warning: high intensity light beam. NEVER look into the lens ! High luminance could result in damage to the eye.
- Warning: extremely high brightness laser: This projector uses extremely high brightness laser. Never attempt to look directly into the lens or at the laser.
- Before attempting to remove any of the projector's covers, you must turn off the projector and disconnect from the wall outlet.
- When required to switch off the projector, to access parts inside, always disconnect the power cord from the power net.
- The power input at the projector side is considered as the disconnect device. When required to switch off the projector, to access parts inside, always disconnect the power cord at the projector side. In case the power input at the projector side is not accessible (e.g. ceiling mount), the socket outlet supplying the projector shall be installed nearby the projector and be easily accessible, or a readily accessible general disconnect device shall be incorporated in the fixed wiring.
- Do not place this equipment on an unstable cart, stand, or table. The product may fall, causing serious damage to it and possible injury to the user.
- It is hazardous to operate without lens or shield. Lenses, shields or ultra violet screens shall be changed if they have become visibly damaged to such an extent that their effectiveness is impaired. For example by cracks or deep scratches.
- Exposure to UV radiation: Some medications are known to make individuals extra sensitive to UV radiation. The American Conference of Governmental Industrial Hygienists (ACGIH) recommends



occupational UV exposure for an 8-hour day to be less than 0,1 micro-watts per square centimeters of effective UV radiation. An evaluation of the workplace is advised to assure employees are not exposed to cumulative radiation levels exceeding these government guidelines. The exposure of this UV radiation is allowed for only 1 hour per day for maintenance and service persons.

### To prevent fire hazard

- Do not place flammable or combustible materials near the projector!
- Barco large screen projection products are designed and manufactured to meet the most stringent safety regulations. This projector radiates heat on its external surfaces and from ventilation ducts during normal operation, which is both normal and safe. Exposing flammable or combustible materials into close proximity of this projector could result in the spontaneous ignition of that material, resulting in a fire. For this reason, it is absolutely necessary to leave an "exclusion zone" around all external surfaces of the projector whereby no flammable or combustible materials are present. The exclusion zone must be not less than 100 cm (39.4") for all DLP projectors. The exclusion zone on the lens side must be at least 5 m. Do not cover the projector or the lens with any material while the projector is in operation. Keep flammable and combustible materials away from the projector at all times. Mount the projector in a well-ventilated area away from sources of ignition and out of direct sun light. Never expose the projector to rain or moisture. In the event of fire, use sand, CO2 or dry powder fire extinguishers. Never use water on an electrical fire. Always have service performed on this projector by authorized Barco service personnel. Always insist on genuine Barco replacement parts. Never use non-Barco replacement parts as they may degrade the safety of this projector.
- Slots and openings in this equipment are provided for ventilation. To ensure reliable operation of the projector and to protect it from overheating, these openings must not be blocked or covered. The openings should never be blocked by placing the projector too close to walls, or other similar surface. This projector should never be placed near or over a radiator or heat register. This projector should not be placed in a built-in installation or enclosure unless proper ventilation is provided.
- Projection rooms must be well ventilated or cooled in order to avoid build up of heat.
- Let the projector cool down completely before storing. Remove cord from the projector when storing.

### To prevent projector damage

- Always remove lens cap before switching on the projector. If the lens cap is not removed, it may melt due to the high energy light emitted through the lens. Melting the lens cap may permanently damage the surface of the projection lens.
- Cleaning the booth area would be monthly minimum. Neglecting this could result in disrupting the air flow inside the projector, causing overheating. Overheating may lead to the projector shutting down during operation.
- The projector must always be installed in a manner which ensures free flow of air into its air inlets and unimpeded evacuation of the hot air from its cooling system.
- If more than one projector is installed in a common projection booth, the exhaust air flow requirements are valid for EACH individual projector system. Note that inadequate air extraction or cooling will result in decreased life expectancy of the projector as a whole as well as causing premature failure of the lasers.
- In order to ensure that correct airflow is maintained, and that the projector complies with Electromagnetic Compatibility (EMC) requirements, it should always be operated with all of its covers in place.
- Slots and openings in the cabinet are provided for ventilation. To ensure reliable operation of the product and to protect it from overheating, these openings must not be blocked or covered. The openings should never be blocked by placing the product on a bed, sofa, rug, or other similar surface. This product should never be placed near or over a radiator or heat register. The device should not be placed in a built-in installation or enclosure unless proper ventilation is provided.
- Ensure that nothing can be spilled on, or dropped inside the projector. If this does happen, switch off and unplug the mains supply immediately. Do not operate the projector again until it has been checked by qualified service personnel.
- Do not block the projector cooling fans or free air movement around the projector.
- Do not use this equipment near water.
- Special care for Laser Beams: Special care should be used when DLP projectors are used in the same room as high power laser equipment. Direct or indirect hitting of a laser beam on to the lens can severely damage the Digital Mirror Devices™ in which case there is a loss of warranty.
- Never place the projector in direct sun light. Sun light on the lens can severely damage the Digital Mirror Devices™ in which case there is a loss of warranty.
- Save the original shipping carton and packing material. They will come in handy if you ever have to ship your equipment. For maximum protection, repack your set as it was originally packed at the factory.

- Unplug this product from the wall outlet before cleaning. Do not use liquid cleaners or aerosol cleaners. Use a damp cloth for cleaning. Never use strong solvents, such as thinner or benzene, or abrasive cleaners, since these will damage the cabinet. Stubborn stains may be removed with a cloth lightly dampened with mild detergent solution.
- To ensure the highest optical performance and resolution, the projection lenses are specially treated with an anti-reflective coating, therefore, avoid touching the lens. To remove dust on the lens, use a soft dry cloth. Do not use a damp cloth, detergent solution, or thinner.
- Rated operating ambient temperature:  $t_a = 0\text{ }^{\circ}\text{C}$  (32 °F) to  $50\text{ }^{\circ}\text{C}$  (122 °F).
- Rated operating humidity: 10% RH to 85% RH (non-condensing). This projector can be set to any angle within 360° range.
- Allowing proper space around the projector is critical for proper air circulation and cooling of the unit. The dimensions shown here indicate the minimum space required.

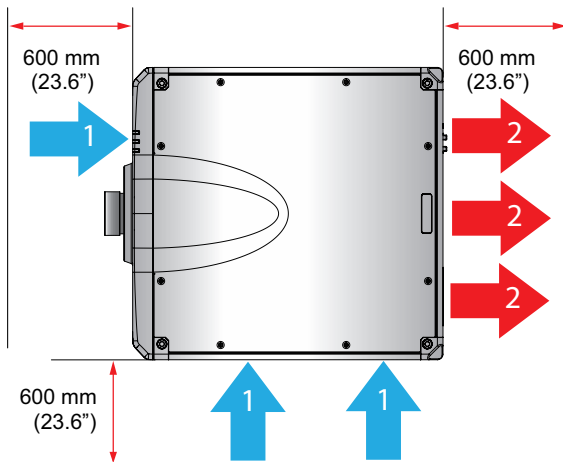
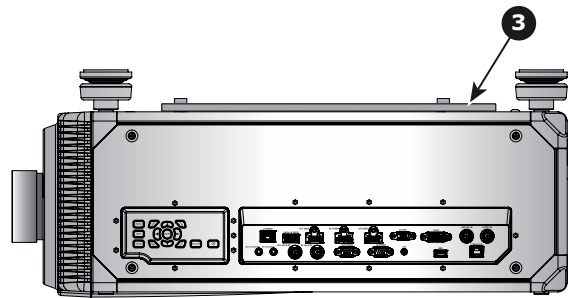

Image 1-1

- 1 Air Inlet.
- 2 Air outlet.
- 3 Ceiling mount plate.



## To prevent battery explosion

- Danger of explosion if battery is incorrectly installed.
- Replace only with the same or equivalent type recommended by the manufacturer.
- For disposal of used batteries, always consult federal, state, local and provincial hazardous waste disposal rules and regulations to ensure proper disposal.

## On servicing

- Do not attempt to service this product yourself, as opening or removing covers may expose you to dangerous voltage potentials and risk of electric shock.
- Refer all servicing to qualified service personnel.
- Attempts to alter the factory-set internal controls or to change other control settings not specially discussed in this manual can lead to permanent damage to the projector and cancellation of the warranty.
- Replacement parts: When replacement parts are required, be sure the service technician has used original Barco replacement parts or authorized replacement parts which have the same characteristics as the Barco original part. Unauthorized substitutions may result in degraded performance and reliability, fire, electric shock or other hazards. Unauthorized substitutions may void warranty.
- Safety check: Upon completion of any service or repairs to this projector, ask the service technician to perform safety checks to determine that the product is in proper operating condition.

## Malfunction unit

Remove all power from the projector and refer servicing to qualified service technicians under the following conditions:

- When the power cord or plug is damaged or frayed.
- If liquid has been spilled into the equipment.
- If the product has been exposed to rain or water.

- If the product does not operate normally when the operating instructions are followed. Adjust only those controls that are covered by the operating instructions since improper adjustment of the other controls may result in damage and will often require extensive work by a qualified technician to restore the product to normal operation.
- If the product has been dropped or the cabinet has been damaged.
- If the product exhibits a distinct change in performance, indicating a need for service.

### **Safety Data Sheets for Hazardous Chemicals**

For safe handling information on chemical products, consult the Safety Data Sheet (SDS). SDSs are available upon request via [safetydatasheets@barco.com](mailto:safetydatasheets@barco.com).

# 1.3 Product safety labels

## Light beam related safety labels for G100 Series

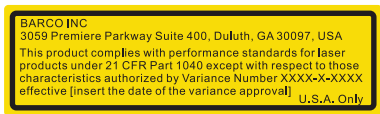
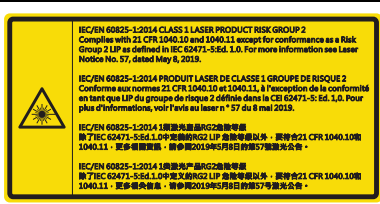
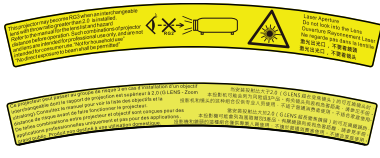
Label image	Label description
	<p>“WARNING: MOUNT ABOVE THE HEADS OF CHILDREN.”</p> <p>Additional warning against eye exposure for close exposures less than 1 m.</p>
	<p>FDA Variance Number (USA only).</p> <p>This product complies with performance standards for laser products under 21 CFR Part 1040 except with respect to those characteristics authorized by Variance Number [see applied label] effective [see applied label]</p>
	<p>This product is classified as Class 1 Laser Product-Risk Group 2 of IEC 60825-1:2014 and also complies with 21 CFR 1040.10 and 1040.11 as a Risk Group 2, LIP (Laser Illuminated Projector) as defined in IEC 62471-5:Ed.1.0. For more information, see Laser Notice No. 57, dated May 8, 2019.</p>
	<p>This projector may become Risk Group 3 product when an interchangeable lens with throw ratio greater than 2.0 (G lens - Ultra Long Zoom) is installed.</p> <p>Refer to the manual for the lens list and hazard distance before operation. Such combinations of projector and lens are intended for professional use only, and are not intended for consumer use.</p> <p>Not for household use.</p> <p>No direct exposure to beam shall be permitted, which can cause injury to the retina in the back of the eye.</p>

## 1.4 Risk Group 3 Safety

### 1.4.1 General considerations

#### Notice on optical radiation from G100 Projector when it becomes Risk Group 3.

- For RG3, no direct exposure to the beam shall be permitted.  
For RG3, operators shall control access to the beam within the hazard distance or install the product at a height that will prevent eye exposure within the hazard distance.
- This projector has one or several built-in Class 4 laser clusters. Disassembly or modification is very dangerous and should never be attempted.
- Any operation or adjustment not specifically instructed by the user's guide creates the risk of hazardous laser radiation exposure.
- Do not open or disassemble the projector as this may cause damage by the exposure of laser radiation.

FOR PROFESSIONAL USE ONLY means installation can only be carried out by Barco AUTHORIZED PERSONNEL familiar with potential hazards associated with high intensity light beams.



**WARNING:** No direct exposure to the beam within the hazard distance shall be permitted, RG3 (Risk Group 3) IEC EN 62471-5:2015



**CAUTION:** Use of controls or adjustments or performance of procedures other than those specified herein may result in hazardous radiation exposure.

#### PPE (Personal Protective Equipment) description.

A skilled person or service person shall be worn protective clothes and goggles when access to restricted area.

Possible skin or eye damage.

Disconnect power before servicing.

### 1.4.2 High Brightness precautions: Hazard Distance



#### HD

Hazard Distance (HD) is the distance measured from the projection lens at which the intensity or the energy per surface unit becomes lower than the applicable exposure limit on the cornea or on the skin. The light beam is considered (to be) unsafe for exposure if the distance from a person to the light source is less than the HD.

#### Restriction Zone (RZ) based on the HD

The HD depends on the amount of lumens produced by the projector and the type of lens installed. See chapter "[High Brightness precautions: Hazard Distance](#)", page 15.

To protect untrained end users (as cinema visitors, spectators) the installation shall comply with the following installation requirements: Operators shall control access to the beam within the hazard distance or install the product at a height that will prevent spectators' eyes from being in the hazard distance. Radiation levels in excess of the limits will not be permitted at any point less than 2.0 meter (SH) above any surface upon which persons other than operators, performers, or employees are permitted to stand or less than 1.0 meter (SW) lateral separation from any place where such persons are permitted to be. In environments where unrestrained behavior is reasonably foreseeable, the minimum separation height should be greater than or equal to 3.0 meter to prevent potential exposure, for example by an individual sitting on another individual's shoulders, within the HD.

These values are minimum values and are based on the guidance provided in IEC 62471-5:2015 section 6.6.3.5.

The installer and user must understand the risk and apply protective measures based upon the hazard distance as indicated on the label and in the user information. Installation method, separation height, barriers, detection system or other applicable control measure shall prevent hazardous eye access to the radiation within the hazard distance.

For example, projectors that have a HD greater than 1 m and emit light into an uncontrolled area where persons may be present should be positioned in accordance with “the fixed projector installation” parameters, resulting in a HD that does not extend into the audience area unless the beam is at least 2.0 meter above the floor level. In environments where unrestrained behavior is reasonably foreseeable, the minimum separation height should be greater than or equal to 3.0 meter to prevent potential exposure, for example by an individual sitting on another individual's shoulders, within the HD. Sufficiently large separation height may be achieved by mounting the image projector on the ceiling or through the use of physical barriers.

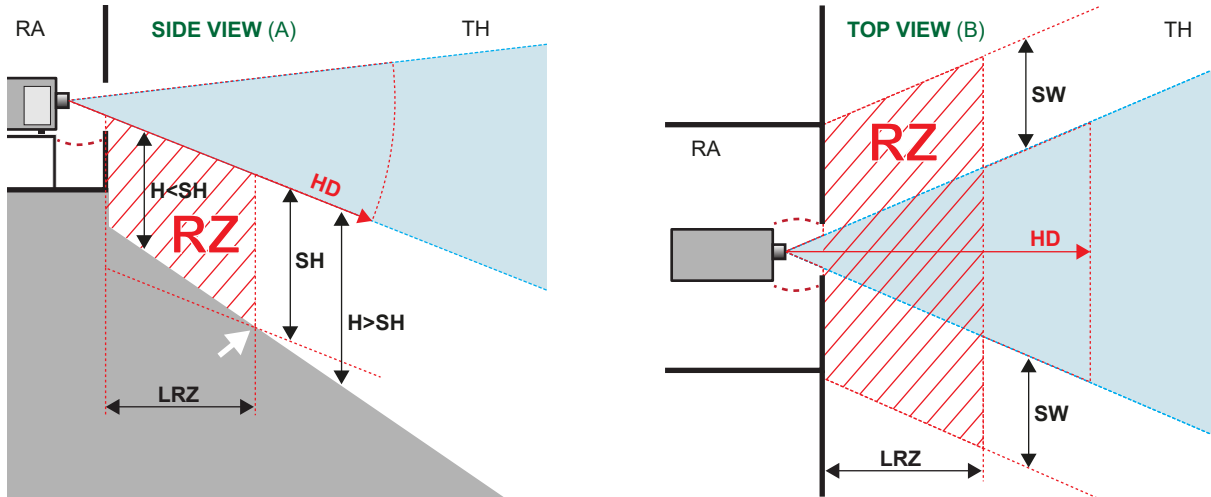

Image 1-2

- A** Side view
- B** Top view
- RA** Restricted Access location (boot area of projector).
- TH** Theater
- RZ** Restriction Zone in the theater
- HD** Hazard Distance
- LRZ** Length Restriction Zone in the theater
- H** Height between surface floor and the light beam
- SH** Separation Height
- SW** Separation Width

Based on national requirements, no person is allowed to enter the projected beam within the zone between the projection lens and the related hazard distance (HD). This shall be physically impossible by creating sufficient separation height or by placing barriers. The minimum separation height takes into account the surface upon which persons other than operator, performers or employees are permitted to stand.

On [Image 1-3](#) a typical setup is displayed. It must be verified if these minimum requirements are met. If required a restricted zone (RZ) in the theater must be established. This can be done by using physical barrier, like a red rope as illustrated in [Image 1-3](#).

The restricted area sticker can be replaced by a sticker with only the symbol.

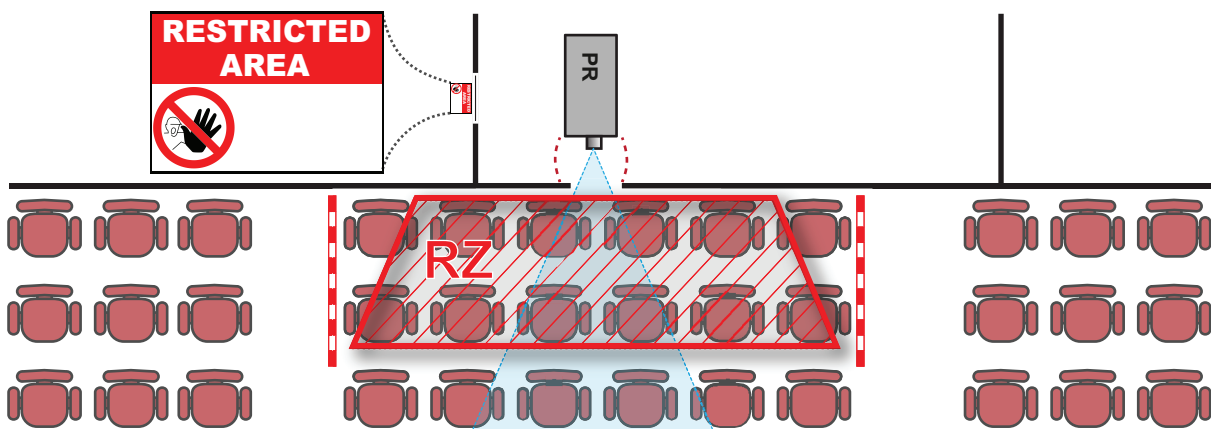

Image 1-3

### USA market

For LIPs (Laser Illuminated Projectors) installed in the USA market other restriction zone conditions apply.

LIPs for installation in restrained environment (cinema theaters, business rooms, class rooms, museums ...) shall be installed at height vertically above the floor such that the bottom plane of the hazard distance zone shall be no lower than 2.5 meters above the floor. Horizontal clearance to the hazard distance zone shall be

not less than 1 meter. Alternatively, in case the height of the separation barrier for the horizontal clearance is at least 1 meter high then the horizontal clearance (SW) can be reduced to:

- 0 meter if the height of the hazard zone is minimum 2.5 meter.
- 0.1 meter if the height of the hazard zone is minimum 2.4 meter.
- 0.6 meter if the height of the hazard zone is minimum 2.2 meter.

LIPs for installations in unrestrained environment (concerts, ...) shall be installed at a height vertically above the floor such that the bottom plane of the Hazard distance Zone shall be no lower than 3 meters above the floor. Horizontal clearance to the hazard distance zone shall be not less than 2.5 meters. Any human access horizontally to the Hazard Zone, if applicable, shall be restricted by barriers. If human access is possible in an unsupervised environment, the horizontal or vertical clearances shall be increased to prevent exposure to the hazard distance zone.

The LIP shall be installed by Barco or by a trained and Barco-authorized installer or shall only be transferred to laser light show variance holders. This is applicable for dealers and distributors since they may need to install the LIP (demo install) and/or they transfer (sell, rent, lease) the LIP. Dealers and distributors shall preserve sales and installation records for a period of 5 years. Variance holders may currently hold a variance for production of Class IIIB and IV laser light shows and/or for incorporating RG3 LIPs. Laser light show variance for RG3 LIPs can be requested by mailing the application to RadHealthCustomerService@fda.hhs.gov.

The installation checklist for laser illuminated RG3 projectors must be fully completed after the installation. The installation checklist can be downloaded from the Barco website. The installer shall preserve the checklist for a period of 5 years.

Install one or more readily accessible controls to immediately terminate LIP projection light. The power input at the projector side is considered as a reliable disconnect device. When required to switch off the projector, disconnect the power cord at the projector side. In case the power input at the projector side is not accessible (e.g. truss mount), the socket outlet supplying the projector shall be installed nearby the projector and be easily accessible, or a readily accessible general disconnect device shall be incorporated in the fixed wiring.

### 1.4.3 HD for fully enclosed projection systems

**HD**  
 Hazard Distance (HD) is the distance measured from the projection lens at which the intensity or the energy per surface unit becomes lower than the applicable exposure limit on the cornea or on the skin. The light beam is considered (to be) unsafe for exposure if the distance from a person to the light source is less than the HD.

#### Restriction Zone (RZ) based on the HD

The projector is also suitable for rear projection applications; projecting a beam onto a diffuse coated projection screen. As displayed in [Image 1-4](#) two areas should be considered: the restricted enclosed projection area (RA) and the observation area (TH).

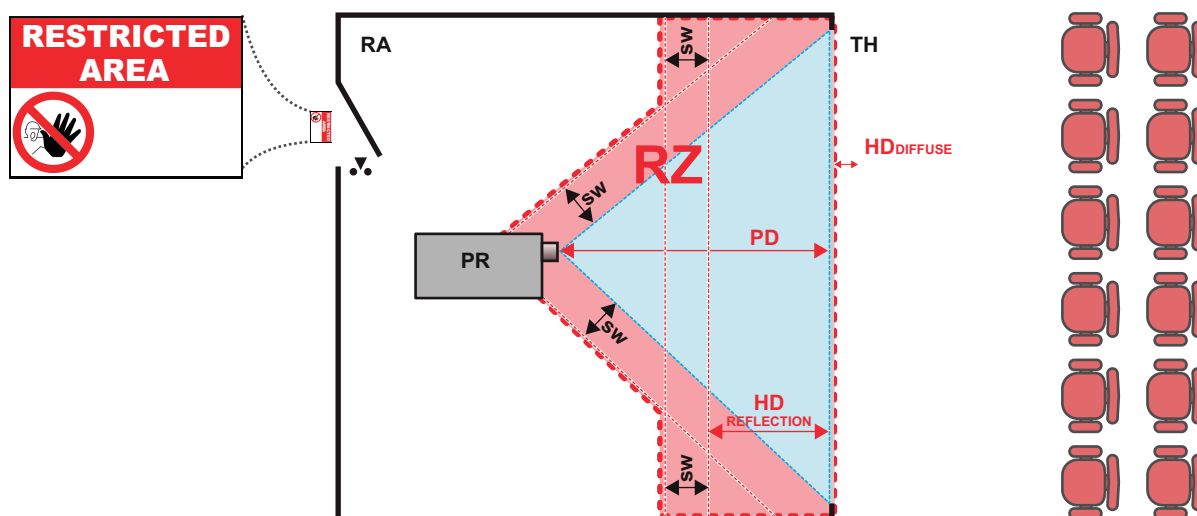

Image 1-4

**RA** Restricted Access location (enclosed projection area).  
**PR** Projector.  
**TH** Theater (observation area).

**RZ** Restriction Zone.  
**PD** Projection Distance.  
**SW** Separation Width. Must be minimum 1 meter.

For this type of setup 3 different HD shall be considered:

- HD as discussed in “[High Brightness precautions: Hazard Distance](#)”, page 15, relevant for intrabeam exposure.
- $HD_{\text{reflection}}$  : the distance that has to be kept restrictive related to the reflected light from the rear projection screen.
- $HD_{\text{diffuse}}$  : the relevant distance to be considered while observing the diffuse surface of the rear projection screen.

As described in “[High Brightness precautions: Hazard Distance](#)”, page 15, it is mandatory to create a restricted zone within the beam areas closer than any HD. In the enclosed projection area the combination of two restricted zones are relevant: The restricted zone of the projected beam toward the screen; taking into account 1 meter Separation Width (SW) from the beam onward. Combined with the restricted zone related to the rear reflection from the screen ( $HD_{\text{reflection}}$ ); also taking into account a 1 meter lateral separation.

The  $HD_{\text{reflection}}$  distance equals 25% of the difference between the determined HD distance and the projection distance to the rear projection screen. To determine the HD distance for the used lens and projector model see chapter “[High Brightness precautions: Hazard Distance](#)”, page 15.

$$HD_{\text{reflection}} = 25\% (HD - PD)$$

The light emitted from the screen within the observation shall never exceed the RG2 exposure limit, determined at 10 cm. The  $HD_{\text{diffuse}}$  can be neglected if the measured light at the screen surface is below 5000 cd/m<sup>2</sup> or 15000 LUX.



## 1.5 Regulatory

### UK Compliance

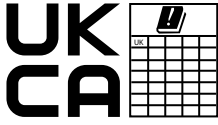

This product is fit for use in the UK.

**Authorised Representative:** Barco UK Ltd

**Address:** Building 329, Doncastle Road  
Bracknell RG12 8PE, Berkshire, United Kingdom

### L'information des consommateurs sur la règle de tri





# Prepare to install

# 2

2.1	Installation requirements .....	22
2.2	Initial inspection.....	24
2.3	Getting to know the projector .....	25
2.4	Input/Output (I/O) Panel .....	28
2.5	Control panel.....	29
2.6	Overview of the RCU .....	30
2.7	Adjusting the projector's position.....	31
2.8	Lens selection .....	32
2.9	Lenses.....	33
2.10	Adjusting the image position on the screen .....	36
2.11	Download Projector Toolset.....	38

## About this chapter

Read this chapter before installing G100 projector. It contains important information concerning installation requirements for the G100 projector, such as minimum and maximum allowed ambient temperature, humidity conditions, required safety area around the installed projector, required power net, etc.

Furthermore, careful consideration of things such as image size, ambient light level, projector placement and type of screen to use are critical to the optimum use of the projection system.



Barco provides a guarantee relating to perfect manufacturing as part of the legally stipulated terms of guarantee. Observing the specification mentioned in this chapter is critical for projector performance. Neglecting this can result in loss of warranty.

## 2.1 Installation requirements

### Environment conditions

Table below summarizes the physical environment in which the G100 projector may be safely operated or stored.

Environment	Operating	Non-Operating
Ambient Temperature	0 °C (41 °F) to 50 °C (122 °F)	-10°C (14°F) to 60°C (140°F)
Humidity	10% to 85% RH Non-Condensed	5% to 90% RH Non-Condensed
Altitude	10000 ft maximum at 0°C to 30°C	



Let the projector acclimatize after unpacking. Neglecting this may result in a startup failure of the Light Processor.

### Cooling requirements

The projector is fan cooled and must be installed with sufficient space around the projector head, minimum 100 cm (39.4") to ensure sufficient air flow. It should be used in an area where the ambient temperature, as measured at the projector air inlet, does not exceed +50°C (+122°F).

For 360° installations and multi-projector setups, make sure to have at least 100 cm (39.4") space around the air inlets and outlet of the projector.

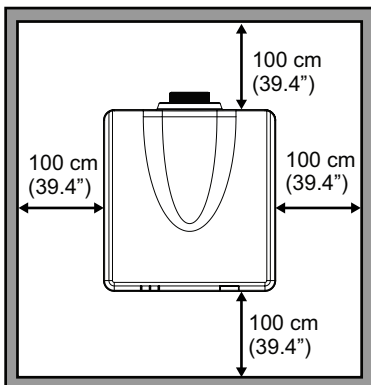

Image 2-1

### Clean air environment

The projector must always be mounted in a manner which ensures the free flow of clean air into the projectors ventilation inlets. For installations in environments where the projector is subject to airborne contaminants such as that produced by smoke machines or similar (these deposit a thin layer of greasy residue upon the projectors internal optics and imaging electronic surfaces, degrading performance), then it is highly advisable and desirable to have this contamination removed prior to it reaching the projectors clean air supply. Devices or structures to extract or shield contaminated air well away from the projector are a prerequisite, if this is not a feasible solution then measures to relocate the projector to a clean air environment should be considered.

Only ever use the manufacturer's recommended cleaning kit which has been specifically designed for cleaning optical parts, never use industrial strength cleaners on the projector's optics as these will degrade optical coatings and damage sensitive optoelectronics components. Failure to take suitable precautions to protect the projector from the effects of persistent and prolonged air contaminants will culminate in extensive and irreversible ingrained optical damage. At this stage cleaning of the internal optical units will be noneffective and impracticable. Damage of this nature is under no circumstances covered under the manufacturer's warranty and may deem the warranty null and void. In such a case the client shall be held solely responsible for all costs incurred during any repair. It is the clients responsibility to ensure at all times that the projector is protected from the harmful effects of hostile airborne particles in the environment of the

projector. The manufacturer reserves the right to refuse repair if a projector has been subject to knowingly neglect, abandon or improper use.

### Main power requirements

The G100 projector operates from a nominal mono phase power net with a separate earth ground PE.

Power requirements : 120-160 V / 200-240 V (+/-10%), 20 A, 50-60 Hz

The power cord required to connect the projector with the power net is delivered with the projector.

### Projector weight

Do not underestimate the weight of the projector. Be sure that the pedestal or ceiling mount on which the projector has to be installed is capable of handling five (5) times the complete load of the system.

Projector	Weight (without lens)
G100-W16, G100-W19	50.0 kg / 110.23 lb
G100-W22	53.5 kg / 117.95 lb

## 2.2 Initial inspection

### General

Before shipment, the projector was inspected and found to be free of mechanical and electrical defects. As soon as the projector is unpacked, inspect for any damage that may have occurred in transit. Save all packing material until the inspection is completed. If damage is found, file claim with carrier immediately. The Barco Sales and Service office should be notified as soon as possible.

### Box content

This projector comes with all the items shown below. Check to make sure your package is complete. Contact your dealer immediately if anything is missing.

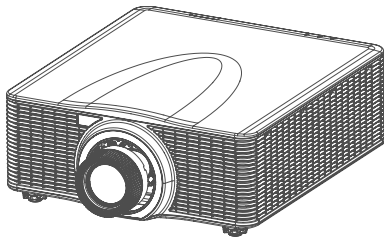

Image 2-2 Projector

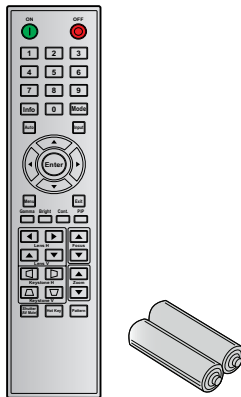

Image 2-3 Remote control with two AAA size batteries

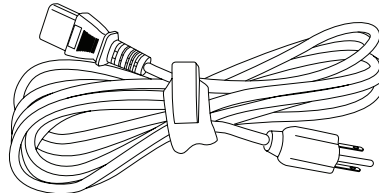

Image 2-4 Power cord

The product Safety Manual and Quick Start Guide are also included. Download the complete and latest updated installation manual and user guide from the Barco website.



The projection lens is an optional item, not a standard accessory in the package.



Due to the difference in applications for each country, some regions may have different accessories.

### Mechanical check

This check should confirm that there are no broken knobs or connectors, that the cabinet and panel surfaces are free of dents and scratches, and that the operating panel is not scratched or cracked. The Barco Sales and Service office should be notified as soon as possible if this is not the case.

## 2.3 Getting to know the projector

### Orientation convention

This manual refers to the left side of the projector as the side at your left hand when standing behind the projector and looking at the projection screen in front of the projector.

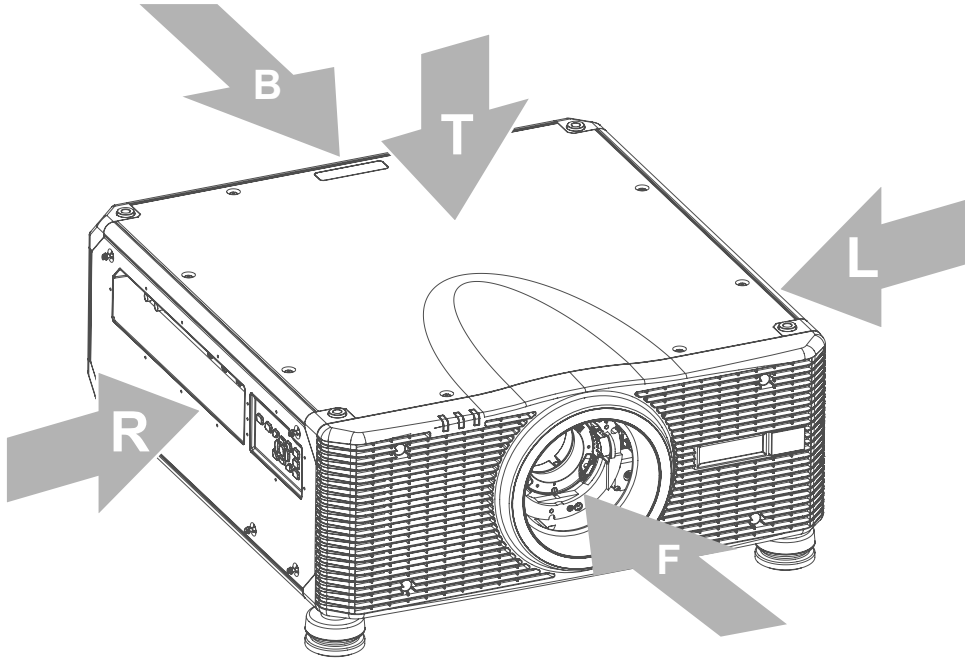

Image 2-5

- |                |                |
|----------------|----------------|
| <b>T</b> Top   | <b>R</b> Right |
| <b>L</b> Left  | <b>B</b> Back  |
| <b>F</b> Front |                |

### Component location

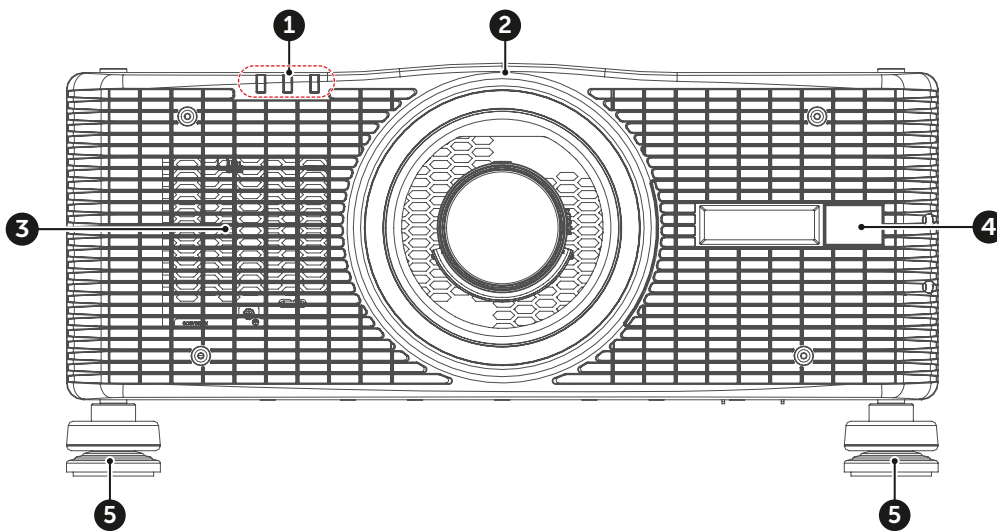

Image 2-6 Front view

- |                                     |                          |
|-------------------------------------|--------------------------|
| <b>1</b> Status LEDs                | <b>4</b> Front IR sensor |
| <b>2</b> Projection lens            | <b>5</b> Adjustment feet |
| <b>3</b> Cooling air vents (intake) |                          |

Prepare to install

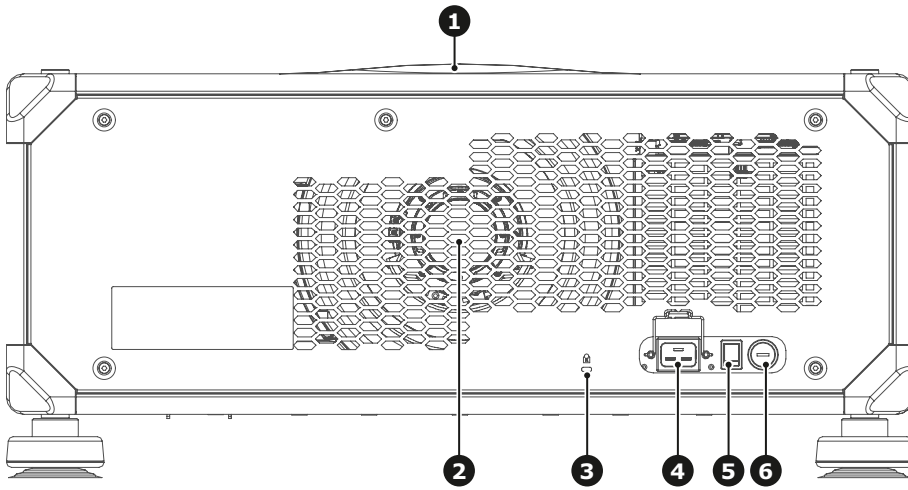

Image 2-7 Rear view

- |   |                             |   |               |
|---|-----------------------------|---|---------------|
| 1 | Top IR sensor               | 4 | AC input      |
| 2 | Cooling air vents (exhaust) | 5 | Power switch  |
| 3 | Kensington lock             | 6 | Fuse location |

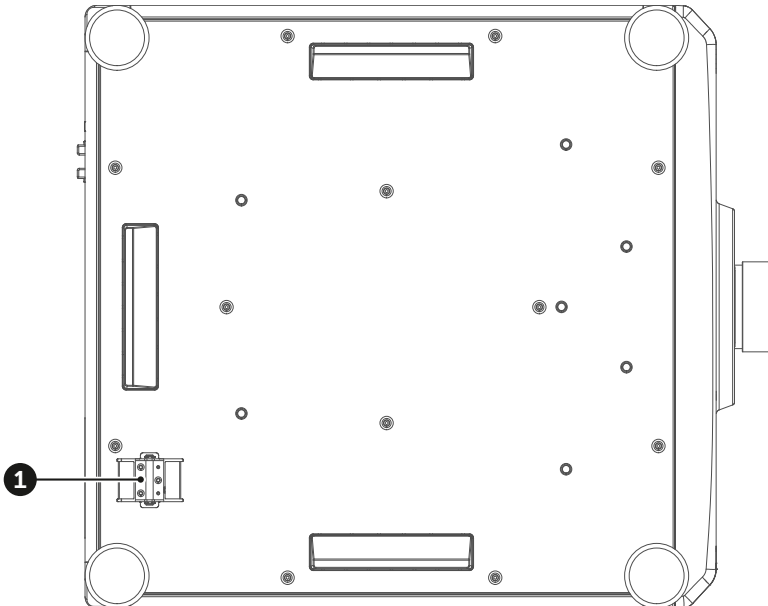

Image 2-8 Bottom view

- 1 Anti-theft bar

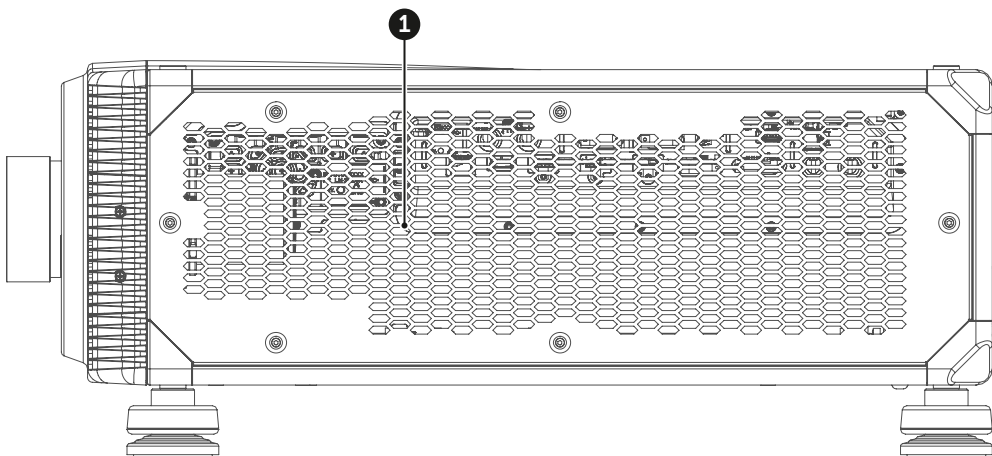

Image 2-9





## 2.4 Input/Output (I/O) Panel

### Input and output ports location

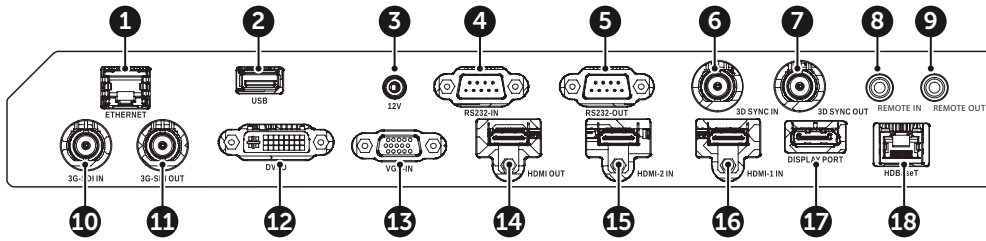

Image 2-12

N-r.	Name	Type	Cable	Example connections <sup>1</sup>
1	Ethernet	Control port	RJ-45 cable	Local or company network
2	USB Type A	Control port	USB power cable	PC, USB flash drive
3	12V	Control port	12V trigger cable	motorized screen, curtain, etc
4	RS-232-IN	Control port	RS-232 cable	PC
5	RS-232-OUT	Control port	RS-232 cable	PC
6	3D Sync IN	Input	3D sync cable	PC
7	3D Sync OUT	Output	3D emitter cable	3D emitter
8	Remote IN	Control port	Wired remote cable	RCU
9	Remote OUT	Control port	Wired remote cable	RCU
10	3G-SDI IN	Input	3G-SDI cable	Camera
11	3G-SDI OUT	Output	3G-SDI cable	Screen, other projectors
12	DVI-D	Input	DVI-D cable	PC
13	VGA-IN	Input	VGA cable	PC
14	HDMI OUT (HDMI 2.0)	Output	HDMI cable	Screen
15	HDMI-2 IN (HDMI 2.0)	Input	HDMI cable	PC, game console, media player
16	HDMI-1 IN (HDMI 2.0)	Input	HDMI cable	PC, game console, media player
17	DisplayPort 1.2a	Input	DisplayPort cable	PC, Mac
18	HDBaseT	Input	RJ-45 cable	Media player

1. These are just a few examples of what you can connect. There may be more options available for each port.

## 2.5 Control panel

### Button location

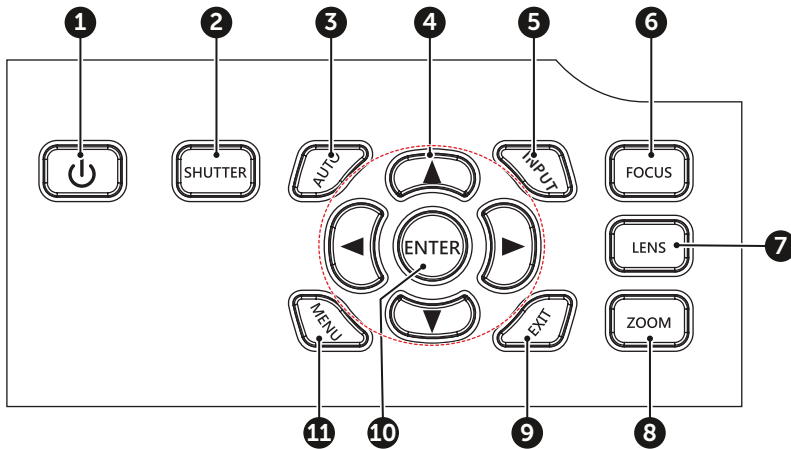

Image 2-13

<b>1</b>	Power	<b>7</b>	Lens
<b>2</b>	Shutter	<b>8</b>	Zoom
<b>3</b>	Auto	<b>9</b>	Exit
<b>4</b>	Arrow keys	<b>10</b>	Enter
<b>5</b>	Input	<b>11</b>	Menu
<b>6</b>	Focus		

### Button function

Button	Function
Power	Turns the projector on or off
Shutter	Opens or closes the shutter
Auto	Automatic setup
Arrow keys	Navigation keys
Input	Selects an input source
Focus	Adjusts the image focus
Lens	Adjusts lens position
Zoom	Adjusts the image size
Exit	Returns to previous menu or exit menu if at top level
Enter	Confirms the settings
Menu	Shows the main menu on screen

## 2.6 Overview of the RCU

### Button identification

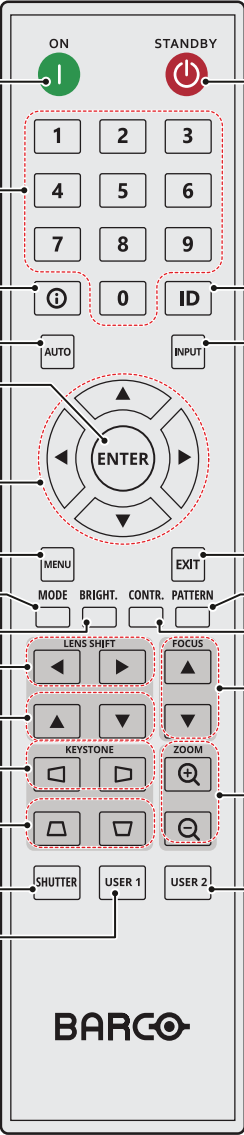
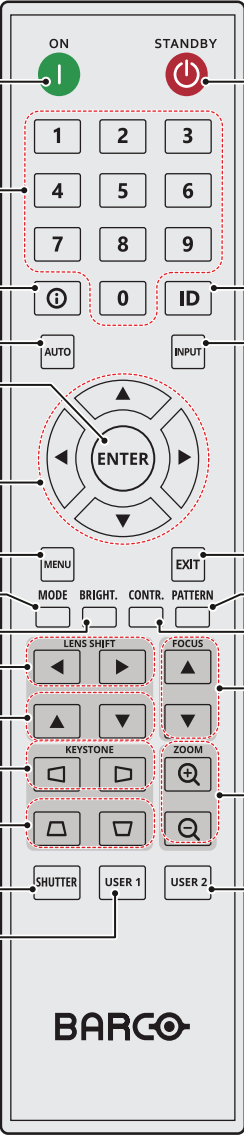
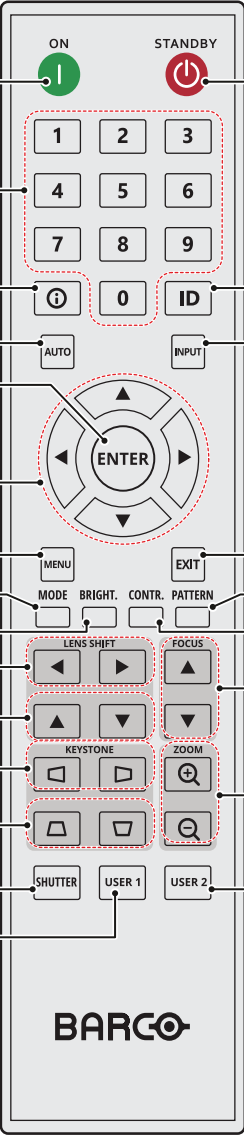
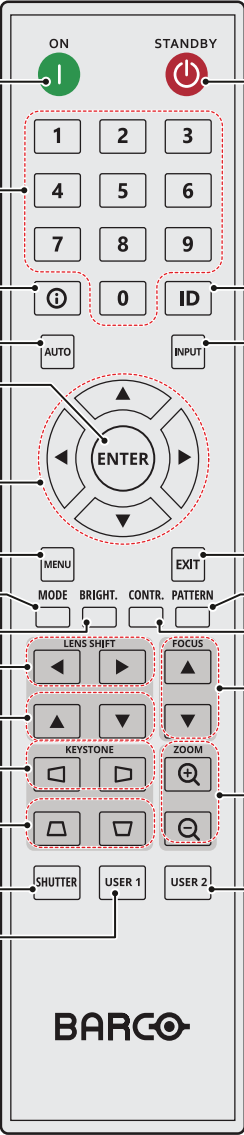
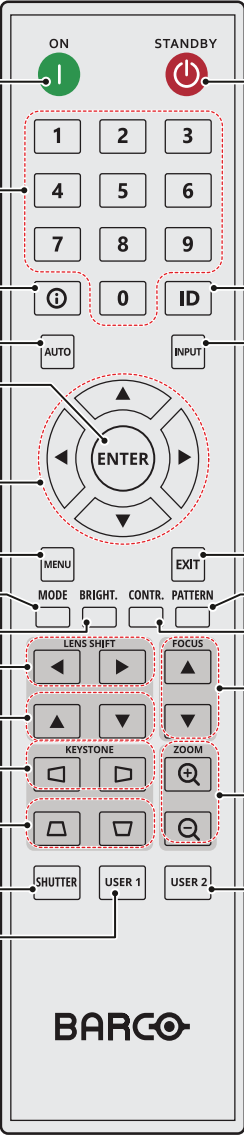
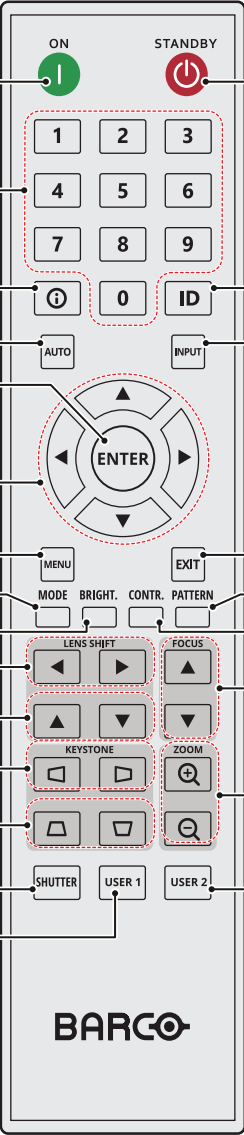
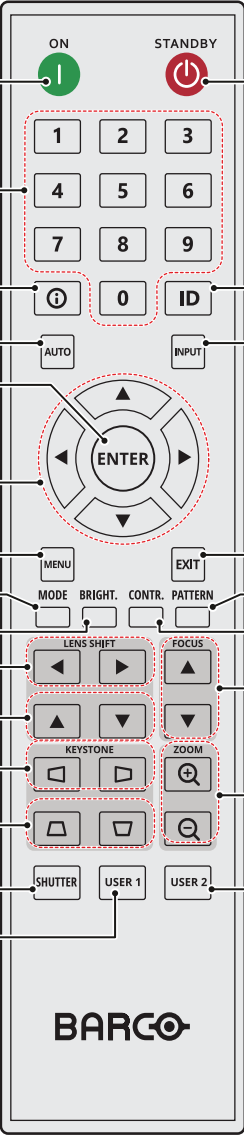
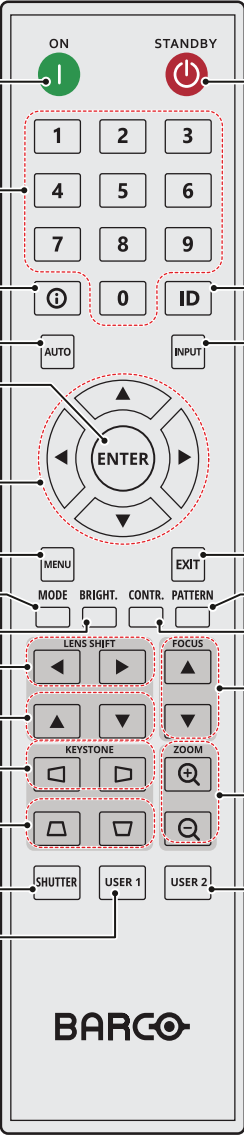
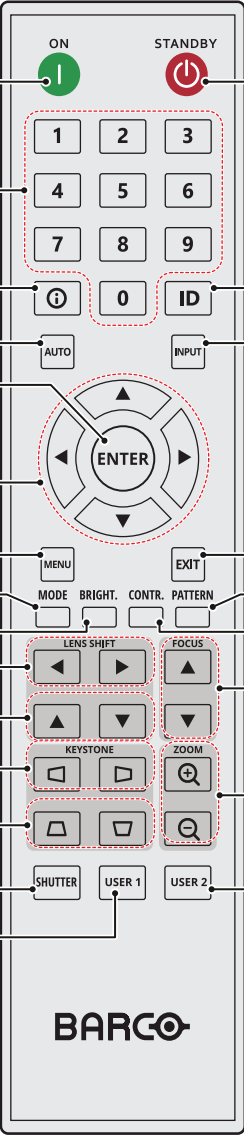
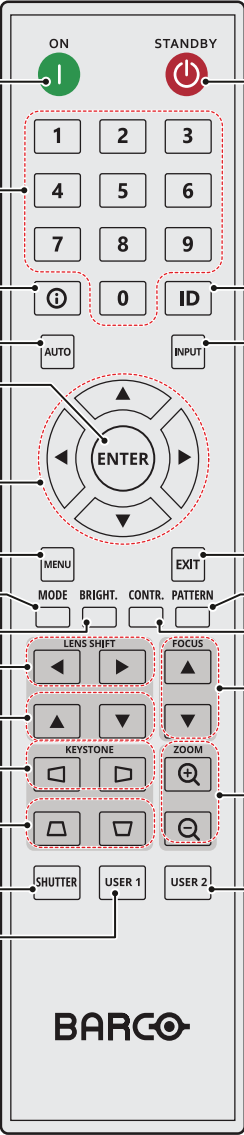
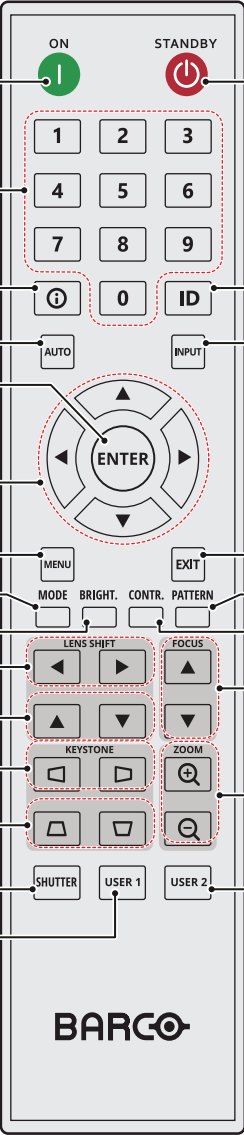
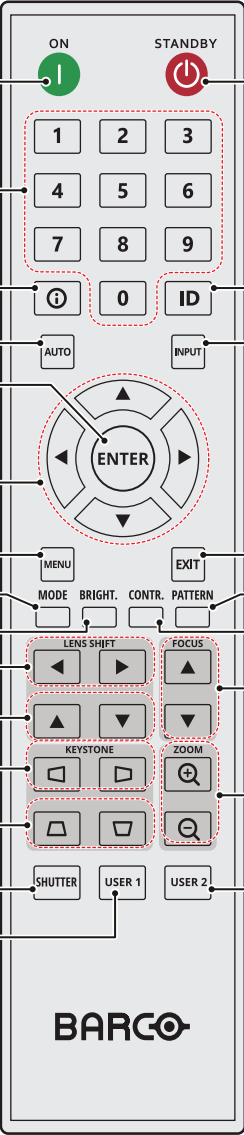
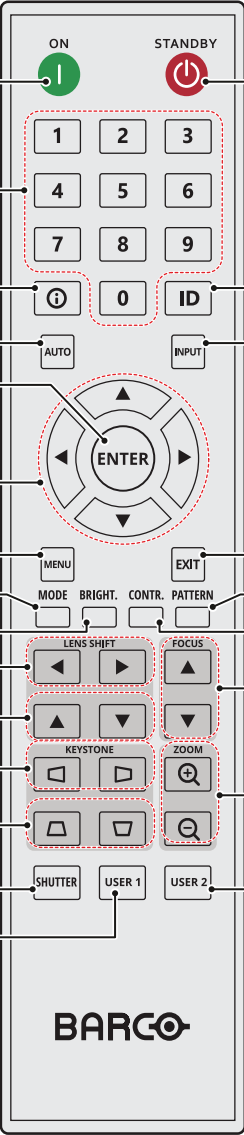
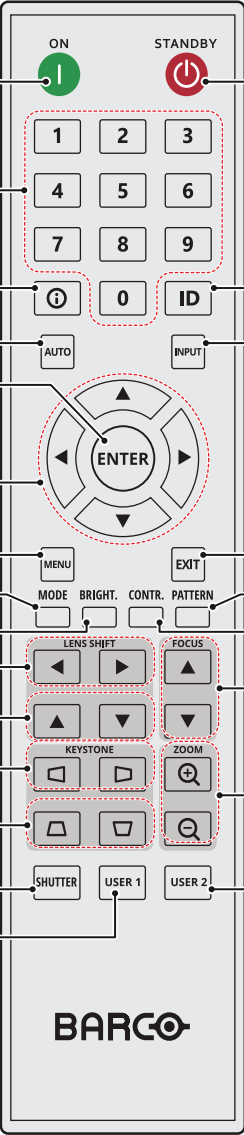
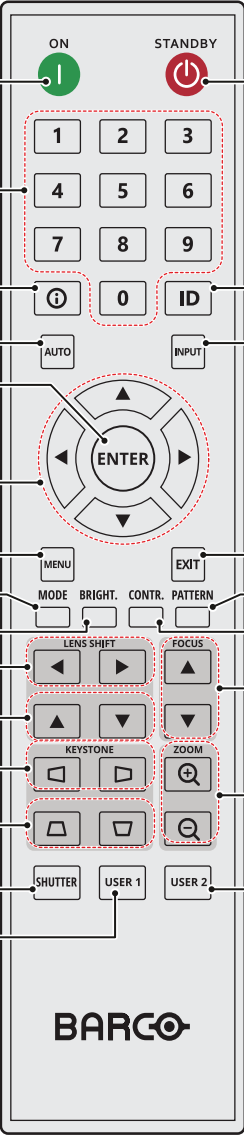
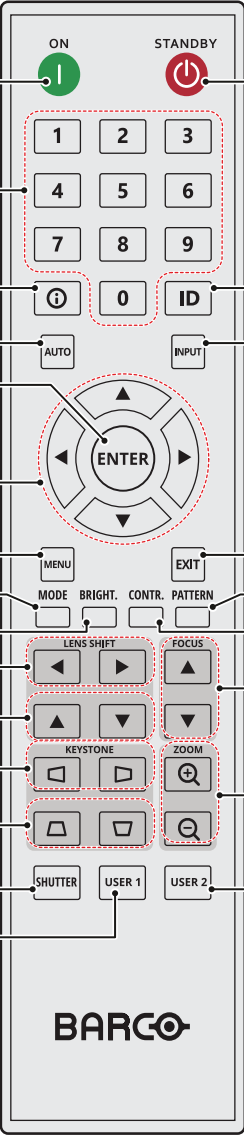
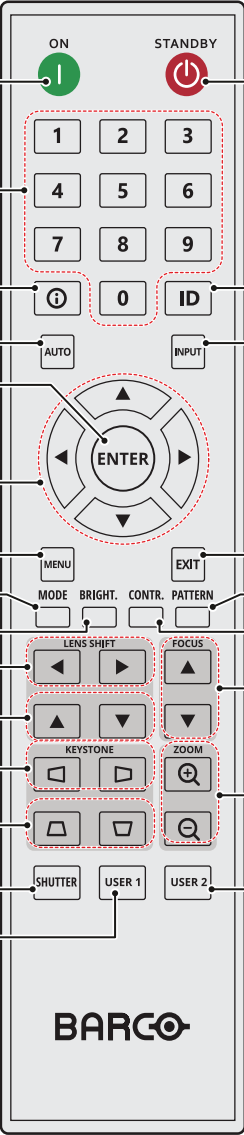
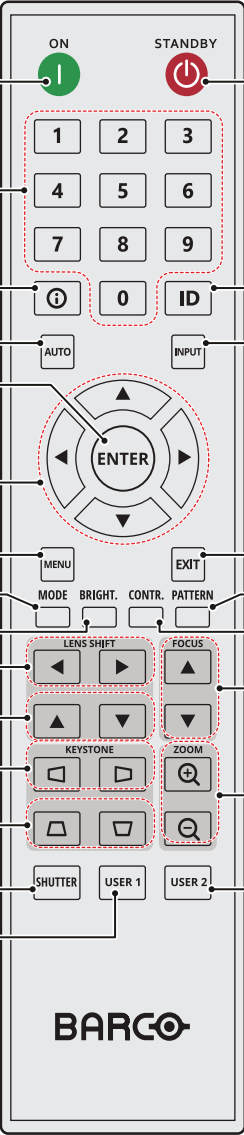
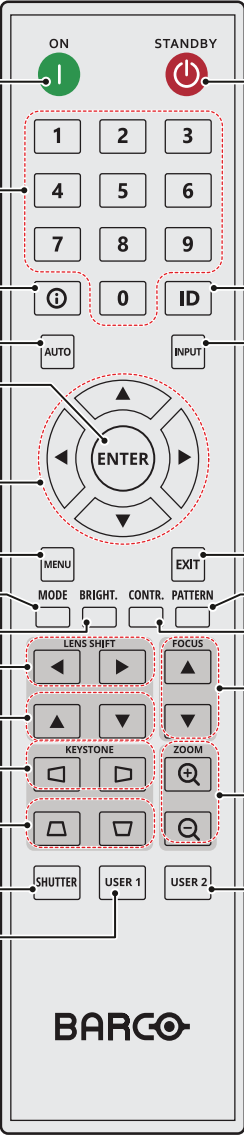
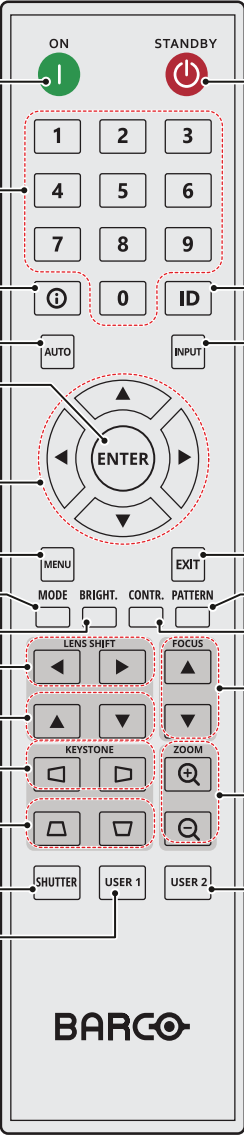
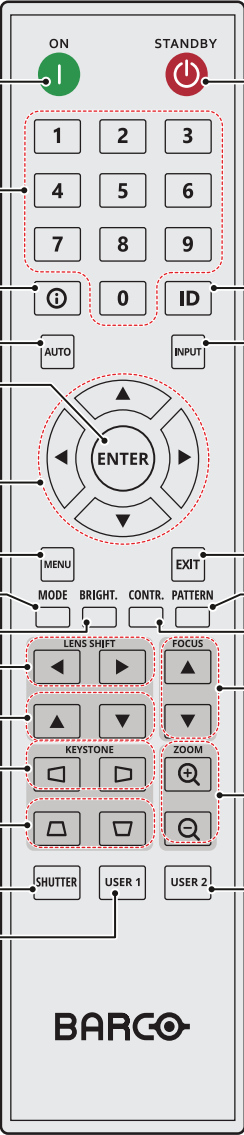
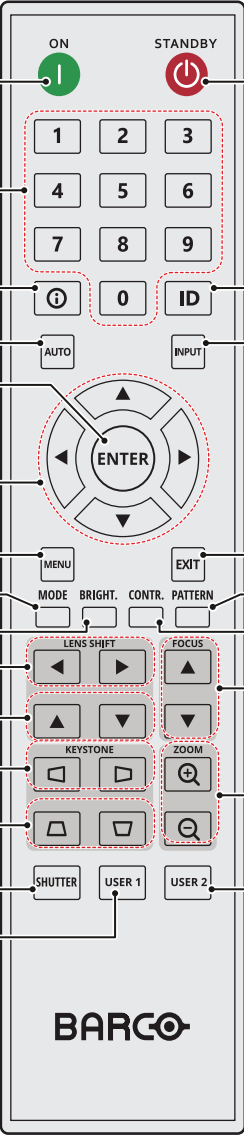
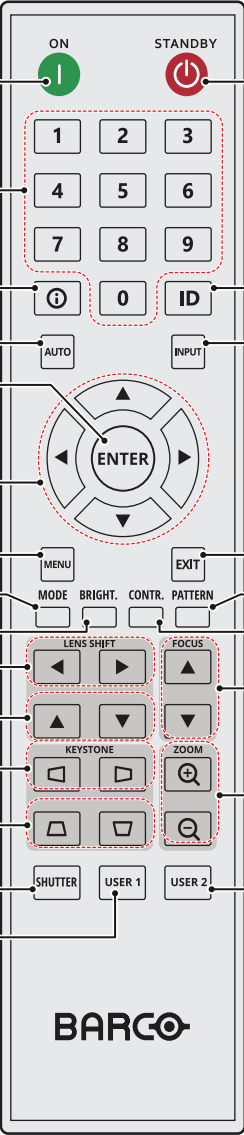
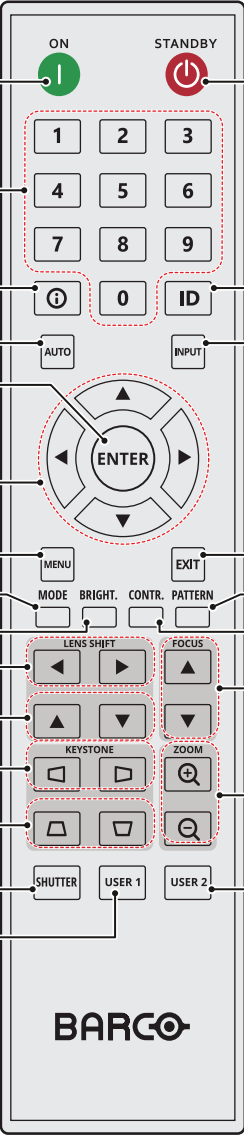
Button location	No.	Button	Function
	1	ON	Turn the projector on.
	2	Standby	Turn the projector off.
	3	Number	Input numbers (0-9)
	4	Info	Display information on the source image.
	5	ID	Set the projector address.
	6	Auto	Automatically synchronize the projector to an input source.
	7	Input	Select an input source manually.
	8	Enter	Confirm an selection.
	9	Arrow keys	Use arrow keys to navigate through the menu or select the appropriate settings.
	10	Menu	Show the main menu on the screen.
	11	Exit	Back to previous menu.
	12	Mode	Press to select the preset display mode.
	13	Pattern	Displays test patterns
	14	Brightness	Set the brightness of the image.
	15	Contrast	Set the contrast of the image.
	16	Lens shift H	Adjust the image position horizontally.
	17	Lens shift V	Adjust the image position vertically.
	18	Focus	Adjust the image focus.
	19	Keystone H	Adjust a horizontally keystone image.
	20	Keystone V	Adjust a vertically keystone image.
	21	Zoom	Adjust the image size.
	22	Shutter	Momentarily turn off/on the screen (AV Mute).
	23	User1	Press to assign custom functions. See user guide for more info.
	24	User2	Press to assign custom functions. See user guide for more info.

## 2.7 Adjusting the projector's position

### Positioning the projector

To determine where to position the projector, consider the size and shape of your screen, the location of your power outlets, and the distance between the projector and the rest of your equipment. Here are some general guidelines:

- Position the projector on a flat surface at a right angle to the screen.
- Position the projector to the desired distance from the screen. The distance between the lens and the screen, the zoom settings, and the video format determine the size of the projected image. For projection distances of each lens, see chapter “[Lenses](#)”, page 33.
- 360 degree free orientation installation:

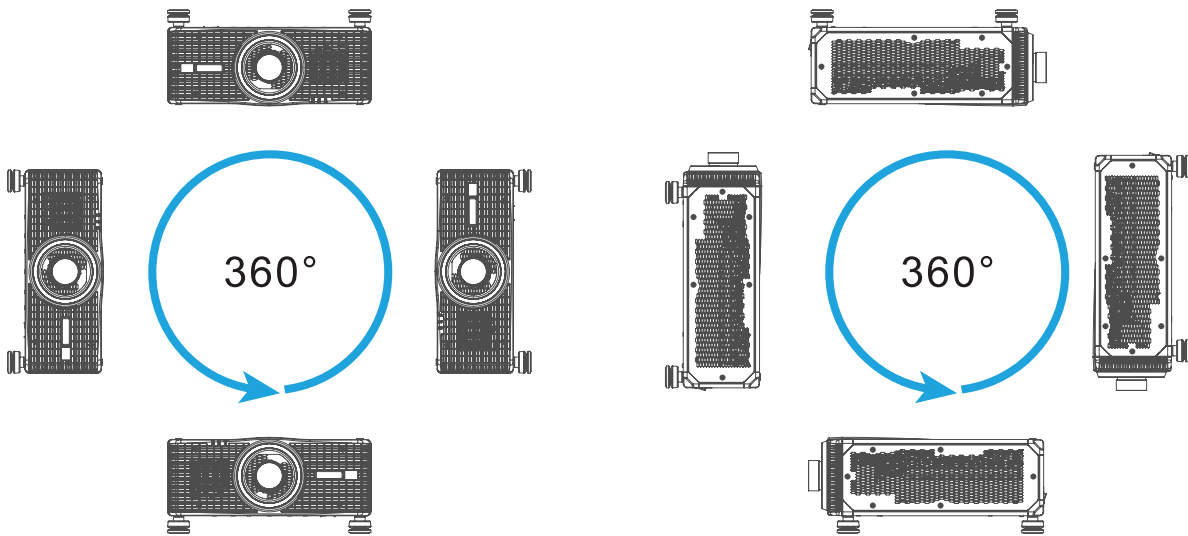

Image 2-14

## 2.8 Lens selection

### How to select the right lens

1. Determine the required screen width (SW).
2. Determine the approximate position of the projector in the room.
3. Start up the *Lens Calculator* on the Barco website: <https://lenscalculator.barco.com/> to determine the possible lenses for your configuration.

The Lens Calculator window opens.

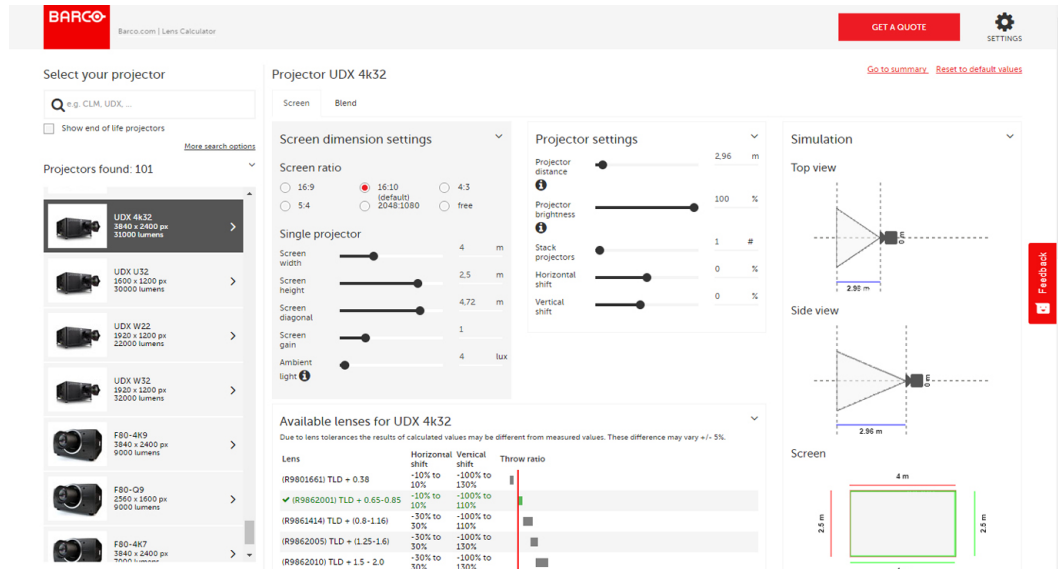

Image 2-15 Lens calculator



The Lens Calculator can also be used to determine the position of the projector when the lens type and screen width is known.







Due to lens tolerances the results of calculated values may be different from measured values. These difference may vary +/- 5%.

## 2.9 Lenses

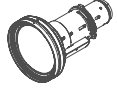

The table below is subject to changes and was last updated on 2022-08-30. Consult Barco's web site for the most recent information about available lenses.

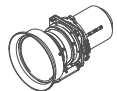
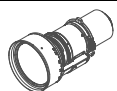
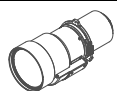
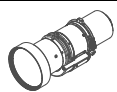
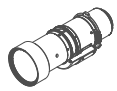
### Available lenses

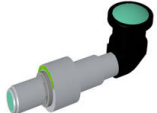
Order No	Description	Image
R9802188	GC+ LENS (0.65 - 0.75 : 1)	
R9802181 <sup>2</sup>	GC LENS (0.84 - 1.02 : 1)	
R9802182 <sup>2</sup>	GC LENS (1.02 - 1.36 : 1)	
R9802183	GC LENS (1.2 - 1.5 : 1)	
R98021831 <sup>3</sup>	GC+ LENS (1.2 - 1.5 : 1)	
R9802184	GC LENS (1.5 - 2.0 : 1)	
R98021841 <sup>3</sup>	GC+ LENS (1.5 - 2.0 : 1)	
R9802185	GC LENS (2.0 – 4.0 : 1)	
R98021851 <sup>3</sup>	GC+ LENS (2.0 – 4.0 : 1)	
R9802186	GC LENS (4.0 - 7.2 : 1)	
R98021861 <sup>3</sup>	GC+ LENS (4.0 - 7.2 : 1)	
R9802187	GC+ LENS (7.2 - 10.8 : 1)	
R9801832	FLDX LENS (0.38 : 1) UST 90° (Requires lens adapter <b>R9802360</b> and lens support <b>R9802365</b> . For installation instructions see chapter “UST lens”, page 57.)	

### Lens specification table

Projection Lens	R9802188	R9802181	R9802182	R9802183 R98021831 <sup>3</sup>	R9802184 R98021841 <sup>3</sup>
	Short Zoom	Wide Zoom	Wide Zoom	Wide Zoom	Standard
Throw Ratio	0.65 - 0.75	0.84 - 1.02	1.02 - 1.36	1.2 - 1.5	1.5 - 2
Zoom Ratio	1.15X	1.2X	1.33X	1.25X	1.33X
Throw Distance	0.70~8.08	0.90~10.98	1.10~14.65	1.34~16.69	1.64~21.75
Vertical Lens Shift (optical)	+/- 102%	+/- 74%	+/- 82%	+/- 120%	+/- 120%
Horizontal Lens Shift (optical)	+/- 48%	+/- 26%	+/- 30%	+/- 50%	+/- 50%

- This lens does not support the lens memory feature.
- Lens memory for focus, zoom and shift.

Projection Lens			R9802188		R9802181		R9802182		R9802183 R98021831 <sup>3</sup>		R9802184 R98021841 <sup>3</sup>	
			Short Zoom		Wide Zoom		Wide Zoom		Wide Zoom		Standard	
Screen size			Projection distance (m)									
Diagonal (inch)	Height (m)	Width (m)	Wide (m)	Tele (m)	Wide (m)	Tele (m)	Wide (m)	Tele (m)	Wide (m)	Tele (m)	Wide (m)	Tele (m)
50	0.67	1.08	0.70	0.81	0.90	1.10	1.10	1.46	1.34	1.67	1.64	2.18
60	0.81	1.29	0.84	0.97	1.09	1.32	1.32	1.76	1.60	2.00	1.96	2.61
70	0.94	1.51	0.98	1.13	1.27	1.54	1.54	2.05	1.87	2.34	2.29	3.05
80	1.08	1.72	1.12	1.29	1.45	1.76	1.76	2.34	2.14	2.67	2.62	3.48
90	1.21	1.94	1.26	1.45	1.63	1.98	1.98	2.64	2.40	3.00	2.95	3.92
100	1.35	2.15	1.40	1.62	1.81	2.20	2.20	2.93	2.67	3.34	3.27	4.35
110	1.48	2.37	1.54	1.78	1.99	2.42	2.42	3.22	2.94	3.67	3.60	4.79
120	1.62	2.58	1.68	1.94	2.17	2.64	2.64	3.52	3.21	4.01	3.93	5.22
130	1.75	2.80	1.82	2.10	2.35	2.86	2.86	3.81	3.47	4.34	4.26	5.66
140	1.88	3.02	1.96	2.26	2.53	3.08	3.08	4.10	3.74	4.67	4.58	6.09
150	2.02	3.23	2.10	2.42	2.71	3.30	3.30	4.39	4.01	5.01	4.91	6.53
160	2.15	3.45	2.24	2.58	2.89	3.52	3.52	4.69	4.27	5.34	5.24	6.96
170	2.29	3.66	2.38	2.75	3.08	3.73	3.73	4.98	4.54	5.68	5.57	7.40
180	2.42	3.88	2.52	2.91	3.26	3.95	3.95	5.27	4.81	6.01	5.89	7.83
190	2.56	4.09	2.66	3.07	3.44	4.17	4.17	5.57	5.07	6.34	6.22	8.27
200	2.69	4.31	2.80	3.23	3.62	4.39	4.39	5.86	5.34	6.68	6.55	8.70
250	3.37	5.38	3.50	4.04	4.52	5.49	5.49	7.32	6.68	8.35	8.18	10.88
300	4.04	6.46	4.20	4.85	5.43	6.59	6.59	8.79	8.01	10.02	9.82	13.05
350	4.71	7.54	4.90	5.65	6.33	7.69	7.69	10.25	9.35	11.68	11.46	15.23
400	5.38	8.62	5.60	6.46	7.24	8.79	8.79	11.72	10.68	13.35	13.10	17.40
450	6.06	9.69	6.30	7.27	8.14	9.89	9.89	13.18	12.02	15.02	14.73	19.58
500	6.73	10.77	7.00	8.08	9.05	10.98	10.98	14.65	13.35	16.69	16.37	21.75
550	7.40	11.85	-	-	-	-	-	-	-	-	-	-
600	8.08	12.92	-	-	-	-	-	-	-	-	-	-

Projection Lens			R9802185 R98021851 <sup>3</sup>		R9802186 R98021861 <sup>3</sup>		R9802187		R9801832	
			Long Zoom		Ultra Long Zoom		Ultra Long Zoom		Ultra Short Throw	
Throw Ratio			2 - 4		4 - 7.2		7.2 - 10.8		0.38	
Zoom Ratio			2X		1.8X		1.5X		N.A.	
Throw Distance			2.10~42.43		4.25~76.89		7.75~116.31			
Vertical Lens Shift (optical)			+/- 120%		+/- 120%		+/- 120%			
Horizontal Lens Shift (optical)			+/- 50%		+/- 50%		+/- 50%			
Screen size			Projection distance (m)							
Diagonal (inch)	Height (m)	Width (m)	Wide (m)	Tele (m)	Wide (m)	Tele (m)	Wide (m)	Tele (m)	(m)	
50	0.67	1.08	2.10	4.24	4.25	7.69	7.75	11.63		



Projection Lens			R9802185 R98021851 <sup>3</sup>		R9802186 R98021861 <sup>3</sup>		R9802187		R9801832	
			Long Zoom		Ultra Long Zoom		Ultra Long Zoom		Ultra Short Throw	
60	0.81	1.29	2.52	5.09	5.10	9.23	9.30	13.96		
70	0.94	1.51	2.94	5.94	5.96	10.77	10.86	16.28		
80	1.08	1.72	3.36	6.79	6.81	12.30	12.41	18.61		
90	1.21	1.94	3.78	7.64	7.66	13.84	13.96	20.94		
100	1.35	2.15	4.20	8.49	8.51	15.38	15.51	23.26		
110	1.48	2.37	4.62	9.34	9.36	16.92	17.06	25.59		
120	1.62	2.58	5.04	10.18	10.21	18.45	18.61	27.91		
130	1.75	2.80	5.46	11.03	11.06	19.99	20.16	30.24		
140	1.88	3.02	5.88	11.88	11.91	21.53	21.71	32.57		
150	2.02	3.23	6.30	12.73	12.76	23.07	23.26	34.89		
160	2.15	3.45	6.72	13.58	13.61	24.61	24.81	37.22		
170	2.29	3.66	7.14	14.43	14.46	26.14	26.36	39.55		
180	2.42	3.88	7.56	15.28	15.31	27.68	27.91	41.87		
190	2.56	4.09	7.98	16.12	16.17	29.22	29.47	44.20		
200	2.69	4.31	8.40	16.97	17.02	30.76	31.02	46.52		
250	3.37	5.38	10.50	21.22	21.27	38.45	38.77	58.16		
300	4.04	6.46	12.60	25.46	25.52	46.14	46.52	69.79		
350	4.71	7.54	14.70	29.70	29.78	53.83	54.28	81.42		
400	5.38	8.62	16.80	33.95	34.03	61.52	62.03	93.05		
450	6.06	9.69	18.90	38.19	38.29	69.21	69.79	104.68		
500	6.73	10.77	21.00	42.43	42.54	76.89	77.54	116.31		
550	7.40	11.85	-	-	-	-	-	-		
600	8.08	12.92	-	-	-	-	-	-		

## 2.10 Adjusting the image position on the screen

### On axis / off axis projection

The position of the projector with reference to the screen may also be different depending on the installation. Basically the projector can be positioned in On-Axis or Off-Axis configuration. On-Axis configuration means that the projector is positioned so as to have the centre of the lens coinciding with the centre of the screen. Off-Axis projection is obtained by shifting the lens up, down, left or right.

### Shift range

The lens can be shifted with respect to the DMD (P) which result in a shifted image on the screen (Off-Axis). A 100% shift means that the centre point of the projected image is shifted by half the screen size. In other words, the centre point of the projected image falls together with the outline of the image in an On-Axis projection. Due to mechanical and optical limitations it's recommended to keep the shift values within the field of view (F) as illustrated below. Within these shift ranges the projector and lens perform excellently. Configuring the projector outside these shift ranges will result in a slight decline of image quality.

G100 Vertical Shift range: 120%

G100 Horizontal Shift range: 50%

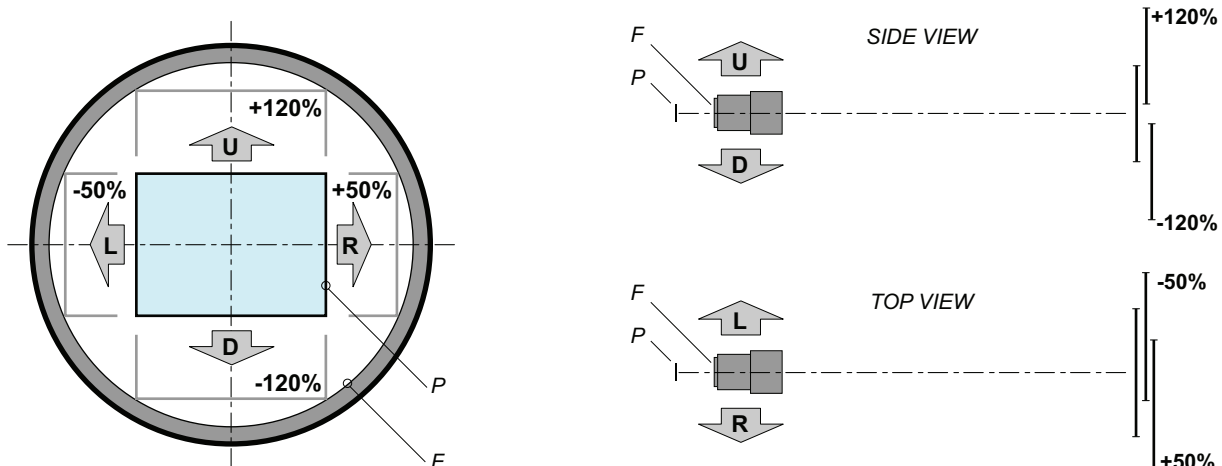

Image 2-16

**D** DMD  
**F** Field of view



It is mechanically possible to shift outside the recommended field of view, but it will result in a decline of image quality depending on the used lens and the zoom position of the used lens. Furthermore, shifting too much in both directions will result in a blurred image corner.

See user guide for instructions on how to shift the lens holder (*Installation* menu > *Lens Shift*).

### Recommendations concerning image reflections in dark images

Image artefacts are reflections of the off-state light on the first lens element back to the chip. In order to avoid these type of image artefacts becoming visible in dark images, it is advised to shift the lens until the reflections are outside of the visual area.

- For lens **R9802181**, you do not have image artefacts when you shift up over +56% vertically.
- For lens **R9802182**, you do not have image artefacts when you shift up over +64% vertically, or if you shift down below -22% vertically.

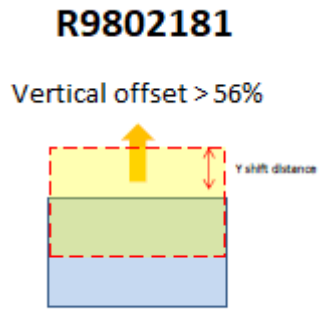

Image 2-17

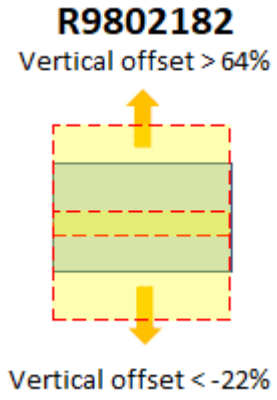

Image 2-18

## 2.11 Download Projector Toolset

### About Projector Toolset

Projector Toolset is a software tool to set up, configure, manage and control Barco projectors.

The Projector Toolset software works with configurations that can be loaded. Several configurations can be controlled simultaneously. Even when the configurations are connected via different ways.

Projector Toolset is a standalone application that runs on a Java Virtual Machine and that does not require extra services to run.



Projector Toolset is only available in a download version, no CD can be ordered.

### Where to find the download file(s)

The program and all necessary plug-ins, as well as the Reference manual can be downloaded for free from [my.barco.com](http://my.barco.com). Registration is necessary.

1. Go to the Barco website [www.barco.com](http://www.barco.com).
2. On the home page, click on **myBarco log in**.
3. On the Sign In page, enter your Email address and your password to login.  
If you are not yet registered click on **New to myBarco?** and follow the instructions. With the created login and password, it is possible to enter the Partner zone of Barco.  
When your login is correct, the Partner zone is free accessible.
4. In the search field, enter Projector Toolset and click on the search icon.
5. Select **Technical Downloads**.
6. Click on Application Software and download the Projector Toolset software package, which includes the device plug-in updates.

When downloading the complete Projector Toolset, this software contains already the latest device plug-ins. When you already have the latest core version of Projector Toolset, it is possible to download only device plug-in updates from the same web site location.

As Projector Toolset is a stand alone application, it is not necessary to install any other software. A Java virtual machine is included with this download.

To download the reference manual, select Reference Guide and download the latest version of the manual for your projector.

### Installation

Download first the reference manual and follow the installation instructions as written in this manual.

# Installation procedures

# 3

3.1	RCU battery installation .....	40
3.2	Connecting the projector with the power net.....	41
3.3	Installing the lens.....	42
3.4	Installing the lens safety cable .....	43
3.5	Boresight (Scheimpflug) adjustment.....	47
3.6	Projector Address (ID).....	52
3.7	Using the RCU .....	53
3.8	Software update .....	54

## 3.1 RCU battery installation

### How to install the batteries of the Remote Control Unit

1. Remove the cover by sliding it in the direction indicated by the arrow
2. Insert two new AAA batteries (observe the polarity).
3. Replace the cover.

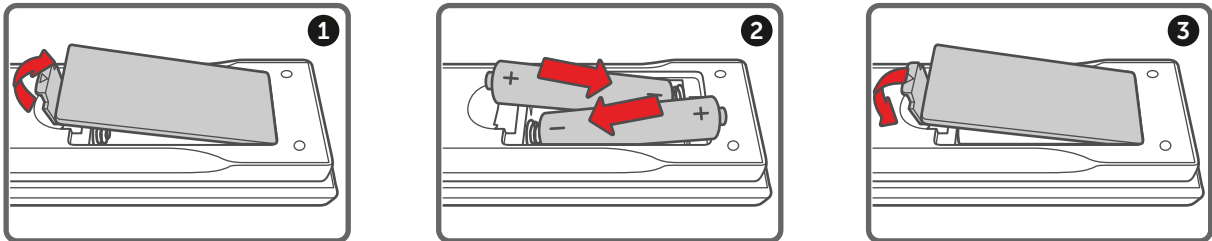

Image 3-1

### Notes for the Remote Control Unit

- Be sure to insert the batteries in the corresponding orientations to match the polarities.
- Do not mix new batteries with used batteries as it would shorten the life of new batteries or cause leakage.
- Only used AAA batteries as instructed; do not attempt to insert different types of batteries into the remote control.
- If the remote is going to be unused for long periods of time, be sure to remove the batteries to prevent leakage, which could damage the remote control.
- The liquid contents in the batteries is harmful to the skin; do not touch the leakage with your bare hands directly. When installing fresh batteries, be sure to clean up the leakage thoroughly.
- Under most circumstances, you only need to point the remote control towards the screen and the IR signal would be reflected off the screen and picked up by the IR sensor on the projector. But under specific circumstances, the projector may fail to receive signals from the remote control due to environmental factors. When this happens, orient the remote control at the projector and try again.
- If the range of effective remote control signal reception decreases or if the remote control stops working, replace the batteries.
- If the infrared receiver is exposed to fluorescent lamp or strong sunlight, the remote control may not operate normally.
- Refer to the regulations enforced by your local government on the disposal of used batteries; improper disposal could damage the environment.

## 3.2 Connecting the projector with the power net



**CAUTION:** Use only the power cord provided with the projector.

### How to connect with local power net

1. Ensure that the power switch stands in the '0' (OFF) position (reference 1)
2. Connect the female side of the power cord with the power input socket of the projector (reference 2).

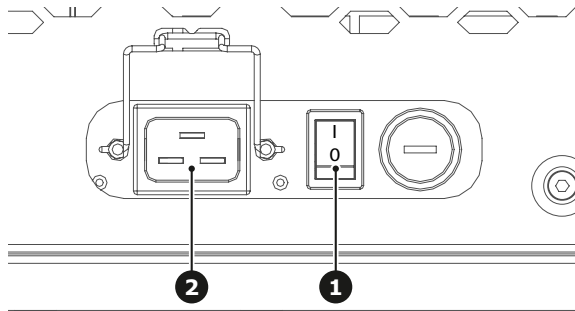

Image 3-2

3. Connect the male side of the power cord to the local power net.



**Caution:** Ensure that the power net meets the power requirements of the projector.



**Warning:** Do not attempt operation if the AC supply and cord are not within the specified voltage and power range.

## 3.3 Installing the lens



This procedure is not applicable for the 90° UST lens. For installation instructions of the 90° UST lens see chapter “UST lens”, page 57.

### How to install the lens

1. Remove the lens cap. Rotate the cap counterclockwise to help remove it.



**Caution:** Lens cap should be removed before installing the lens. If not it will damage the projector.

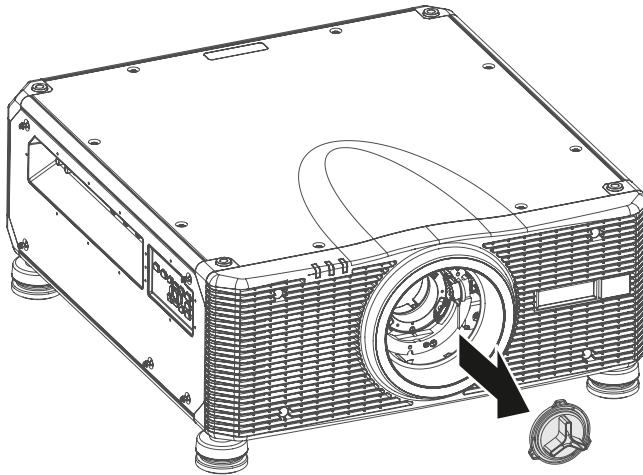

Image 3-3

2. Gently insert the lens in the lens holder.
3. Rotate the lens clockwise to lock the lens.

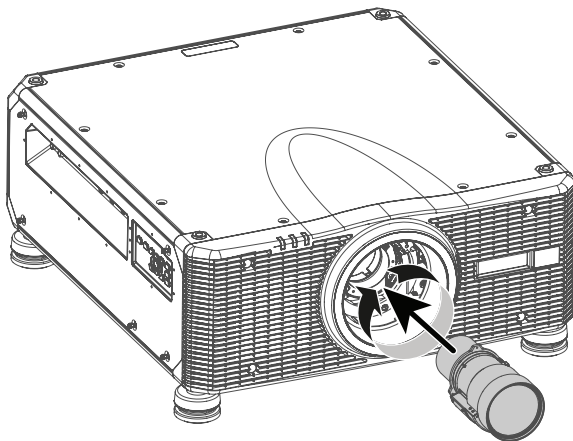

Image 3-4

4. Is the projector installed above the head of people?  
▶ If **yes**, install the lens safety cable. See chapter “Installing the lens safety cable”, page 43.



**CAUTION:** Do not transport the projector with any lens installed.



## 3.4 Installing the lens safety cable

### When to use the lens safety cable

The lens safety cable must be used in any circumstance where the projector is mounted above people. Do this to secure the mounted lens in the lens holder.

### Content of the lens safety cable kit (R9801196)

- Safety Cable (750 mm, Ø3 mm)
- Cable clamp M4 (U-bolt)
- Shackle 7x70 mm
- 20 x Cable clip (16x16 mm, Ø4 mm)<sup>4</sup>

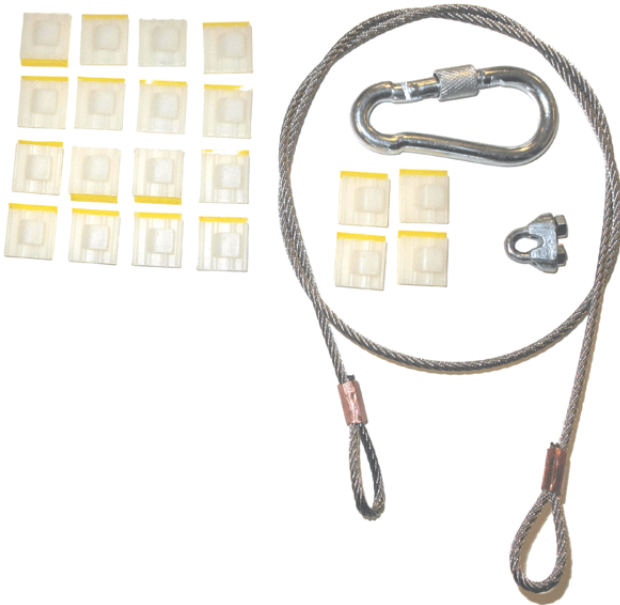

Image 3-5

### How to install the lens safety cable

1. Ensure that the safety cable and its accessories are in good condition (not damaged)
2. Paste four cable clips on the lens body between motor block and lens flange as illustrated (reference 1). Orient the open side of the clips towards the front of the lens.

4. Only four pieces are needed to assemble the safety cable to a lens. When the safety cable is used on another lens, you should not remove the cable clips. Instead, use four new ones. There are enough cable clips in the kit to secure up to five different lenses.

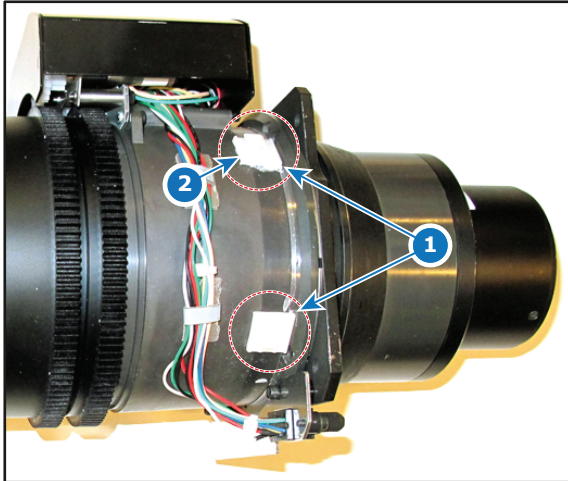

Image 3-6

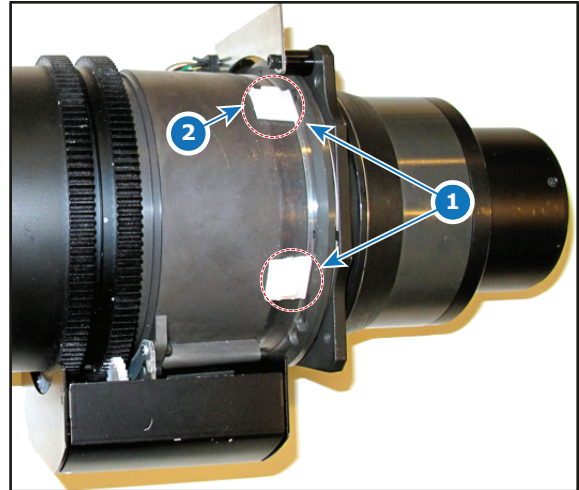

Image 3-7

3. Snap the first loop end of the safety cable into one of the following clips and let the loop end point downwards.
  1. Configuration A: Use the upper clip on the side of the cable bundle (reference 2, [Image 3-6](#)).
  2. Configuration B: Use the upper clip on the non-wired side (reference 2, [Image 3-7](#)).
4. Slide the rest of the cable around the lens counterclockwise. Click the cable into every clip it passes in this loop.



*Note:* Make sure the cable passes between the lens and the cable bundle.

5. Slide the cable through the loop end at the beginning of the cable to create a lasso..

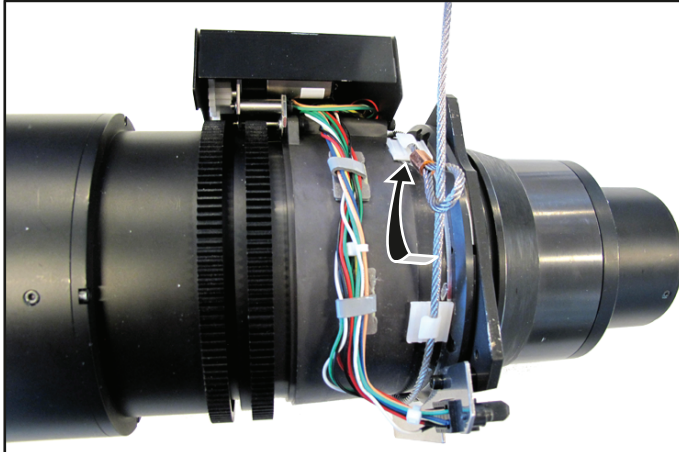

Image 3-8 Example of configuration A

6. Pull the lasso tight around the lens body and install the U-bolt on the lens holder, with the open ends oriented outwards (reference 3). Make sure that both a part of the loop end and the outgoing part of the safety cable are placed in the enclosure.

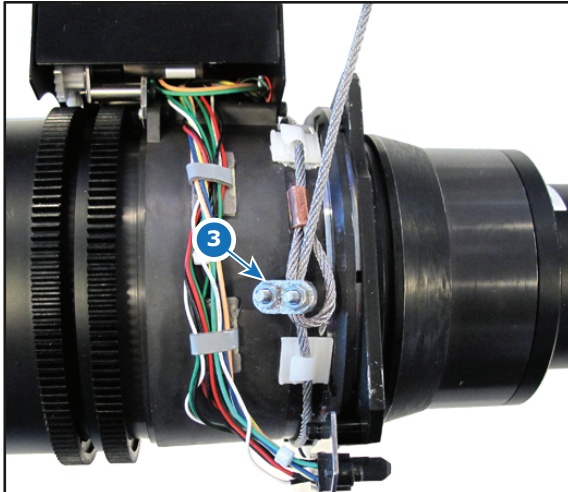

Image 3-9 Example of Configuration A

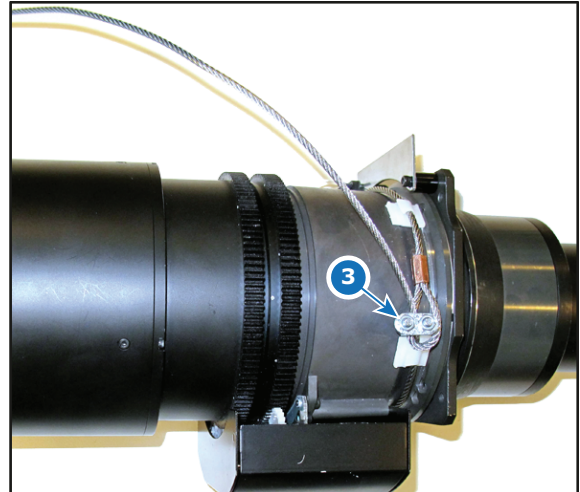



Image 3-10 Example of Configuration B

7. Close the U-bolt and tighten it.

 **Note:** Make sure the safety cable is tightened around the lens before tightening the U-bolt nuts.

8. Place the shackle through the free loop end of the safety cable.
9. Connect the shackle on the truss or rigging frame.

 **Caution:** The safety cable is mounted as backup so that the drop distance is as small as possible. Keep the possible drop distance of the lens as short as possible!

### How to mount the cable to a short barrel lens

1. Paste two cable clips on both sides of the lens as illustrated (reference 1). Orient the open side of the clips towards the outside of the lens.

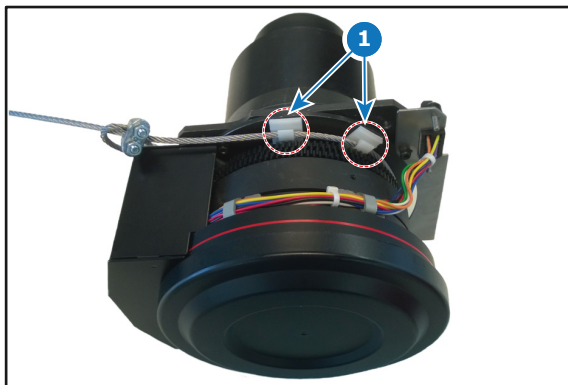

Image 3-11

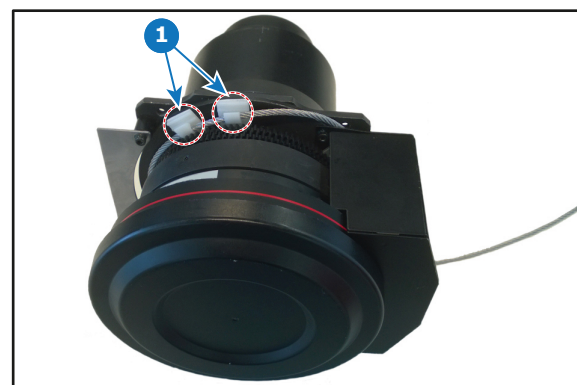

Image 3-12

2. Paste two extra cable clips on the motor block of the lens. Orient the open side to the outside of the lens.

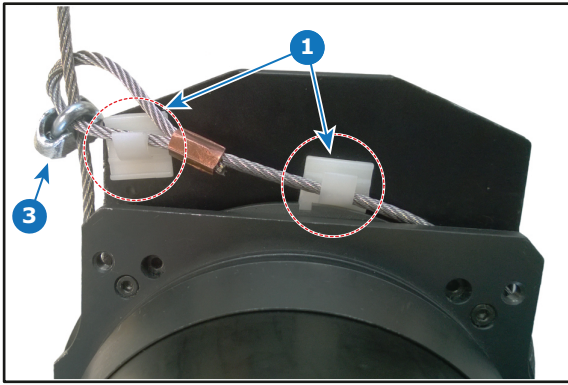



Image 3-13

3. Carefully slide the safety cable through the cable clips. Make sure the cable is placed between the motor block and the cover plate.
4. Slide the cable through the loop end at the beginning of the cable.
5. Mount a U-bolt on the cable, with the open ends oriented outwards (reference 3, [Image 3-13](#)). Make sure that both a part of the loop end and the outgoing part of the safety cable are placed in the enclosure.
6. Close the U-bolt and tighten it.

 **Note:** Make sure the safety cable is tightened around the lens before tightening the U-bolt nuts.

The result should look similar to the following example.

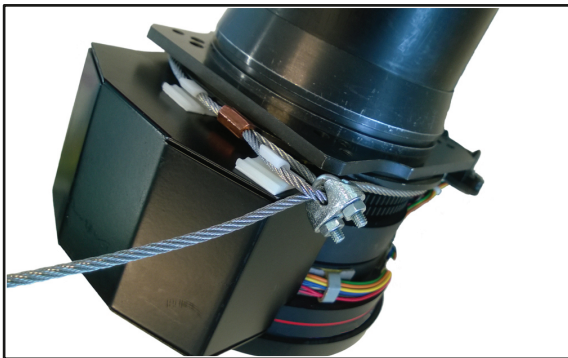

Image 3-14

7. Lead the cable end with the shackle around rigging frame bar or truss bar
  8. Snap the shackle to the straight part of the cable.
- Secure the shackle by screwing the safety ring of the shackle over the open end.

## 3.5 Boresight (Scheimpflug) adjustment

### What is Boresight (Scheimpflug)?

The lens holder has to be adjusted so that the “sharp focus plane” of the projected image falls together with the plane of the screen ( $Fp1 \rightarrow Fp2$ ). This is achieved by changing the distance between the DMD plane and the lens plane ( $Lp1 \rightarrow Lp2$ ). The closer the lens plane comes to the DMD plane the further the sharp focus plane will be. It can occur that you won't be able to get a complete focused image on the screen due to a tilt (or swing) of the lens plane with respect to the DMD plane. This is also known as Scheimpflug's law. To solve this the lens plane must be placed parallel with the DMD plane. This can be achieved by turning the lens holder to remove the tilt (or swing) between lens plane and DMD plane ( $Lp3 \rightarrow Lp4$ ).

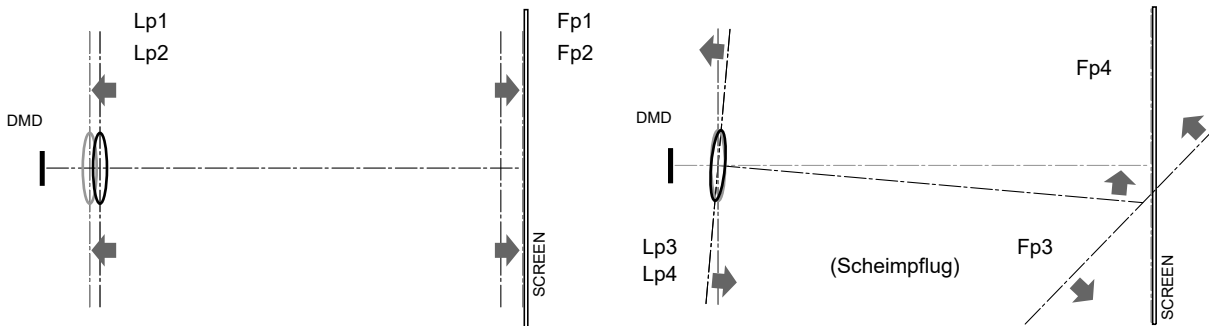

Image 3–15 Boresight (scheimpflug) principle

### Preparations

1. Choose the test pattern of the OSD. Switch to full screen mode
2. Prepare the test area. Verify that the throw ratio of the installed lens matches the requirements of the installation area (projection distance and screen size).
3. Check that the lens is correctly installed.
4. Zoom the lens to its widest opening (maximum image size on the screen).
5. Adjust the focus control to search for the best sharpness of the projected image



#### Boresight tool:

Allen key, hex size 4mm

For lens G LENS (0.65-0.75 : 1), you need 3 boresight extenders (84 mm) and 1 L shape tool or 3 boresight extenders (64 mm and 1 U shape tool).

For G LENS (0.65-0.75 : 1) the floating ring indication must be checked.

## Floating ring for G LENS (0.65-0.75 : 1) lens

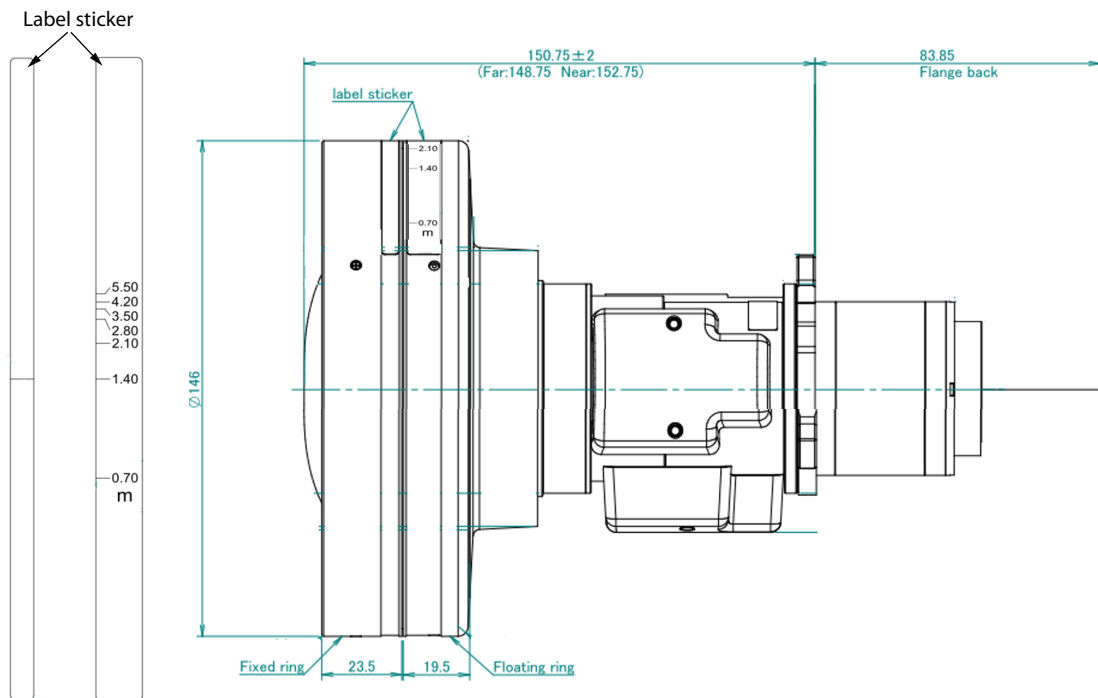

Image 3-16

- Manual adjust floating ring before adjust Zoom& Focus for better optical performance.
- Label scale shows the projection distance.
- The projection distance is from projector lens to screen.

Example:

When the distance between screen and projector lens is 1.4 meter, adjust floating ring scale to “1.40” to have better performance.

### How to adjust

1. Install the extenders.
2. If zone C is in focus on the screen, please check the focal plane of zone A.
  - If clear position is just on the screen → No need to adjust.
  - If clear position is out of the screen (close to projector), rotate screw ① CCW and then screw ②&③ CW for half amount that ① rotated. → repeat until both A and C are clear. (e.g. turning ① CCW in a circle, then turn ②&③ CW in half circle).
  - If clear position is in the screen (far from projector), rotate screw ① CW and then screw ②&③ CCW for half amount that ① rotated. → repeat until both A and C are clear.



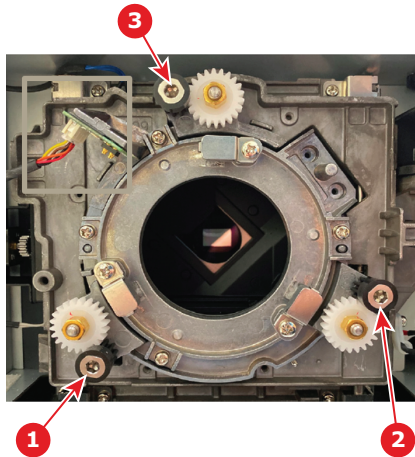
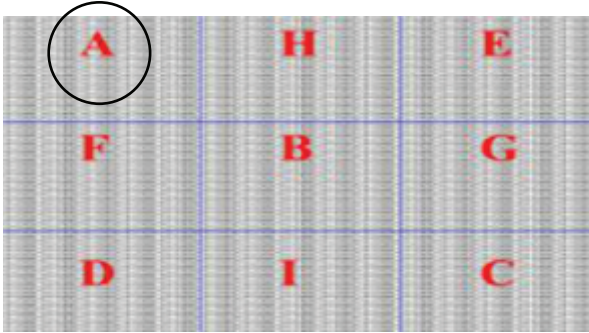



Image 3-17

 **Note:** This process may cause the other areas of the image to slide out of focus. This is totally normal.

3. If zone D is in focus on the screen, please check the focal plane of zone E.
  - If clear position is just on the screen → No need to adjust.
  - If clear position is out of the screen (close to projector), rotate screw ② CCW and then screw ① & ③ CW for half amount that ② rotated. → repeat until both D and E are clear. (e.g. turning ② CCW in a circle, then turn ① & ③ CW in half circle)
  - If clear position is in the screen (far from projector), rotate screw ② CW and then screw ① & ③ CCW for half amount that ② rotated. → repeat until both D and E are clear.

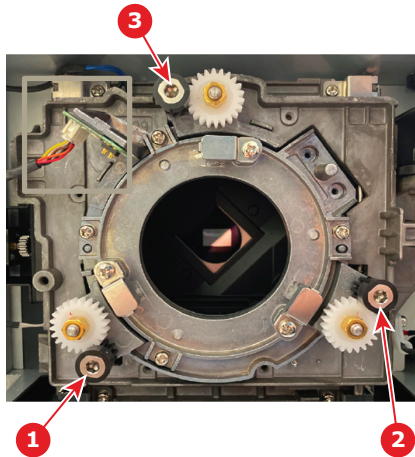
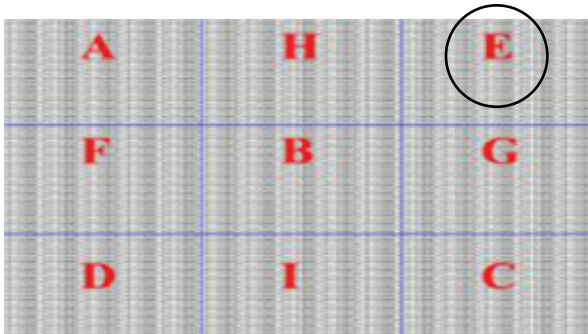



Image 3-18

 **Note:** This process may cause the other areas of the image to slide out of focus. This is totally normal.

4. If zone H is in focus on the screen, please check the focal plane of zone I.
  - If clear position is just on the screen → No need to adjust.
  - If clear position is out of the screen (close to projector), rotate screw ③ CCW and then screw ① & ② CW for half amount that ③ rotated. → repeat until both H and I are clear. (e.g. turning ③ CCW in a circle, then turn ① & ② CW in half circle).
  - If clear position is in the screen (far from projector), rotate screw ③ CW and then screw ① & ② CCW for half amount that ③ rotated. → repeat until both H and I are clear.



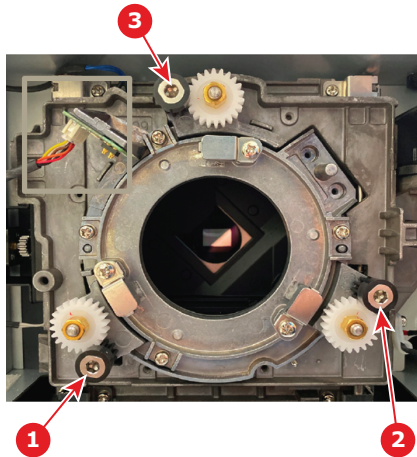
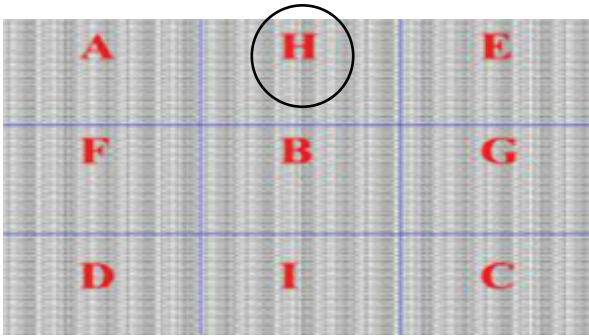

Image 3-19



*Note:* This process may cause the other areas of the image to slide out of focus. This is totally normal.

5. After the above adjustment of the viewing axis, the projected image from zone A to zone I still cannot achieve a clear focus on the screen. Please turn the boresight screws ① to ③ counterclockwise to the end (STOP), and then turn clockwise 2 circles to the design value position. To improve the focus, go to step 2 and repeat the complete procedure.

## 3.6 Projector Address (ID)

### About the projector address

The Remote Control supports individual addressing of multiple projectors. The remote receiver on the projector can be set with a specific number from 00 to 99, and the projector only responds to the IR remote set to the same number. The default ID code of the RCU (also known as the broadcast address) is 00. This specific address allows the RCU to control all projectors within its effective range.

### How to set the projector address on the RCU

1. Keep **ID Key** pressed in.
2. After few seconds, enter the address with the numeric keys while keeping the **ID Key** pressed in.



*Tip:* Always enter two digits. E.g. for address 2, enter 02.

3. Release the **ID Key**.



The projector address can be set in: *Communication > Remote setup > Remote code.*

## 3.7 Using the RCU

### Effective range

The Infrared (IR) remote control sensors are located on the front and top sides of the projector. To have the remote control functions correctly, make sure of the following:

- The maximum range between the remote control and the sensor is 30 m (98.4 ft).
- Ensure to hold the remote at the following angles towards one of the IR remote control sensors:
  - horizontally:  $\pm 30^\circ$
  - vertically:  $\pm 20^\circ$
- Make sure there are no obstacles between the remote control and the IR sensors on the projector.
- Make sure the IR transmitter of the remote control is not directly being shined by sunlight or fluorescent lamps.
- Keep a minimum distance of 2 m between the remote control and nearby fluorescent lamps. If not, the RCU might malfunction.
- If the projector and remote are within very short distance, the RCU may become ineffective.
- When you aim at the screen, the effective distance is less than 5 m from the remote control to the screen and reflecting the IR beams back to the projector. However, the effective range might change depending on type of screen used.

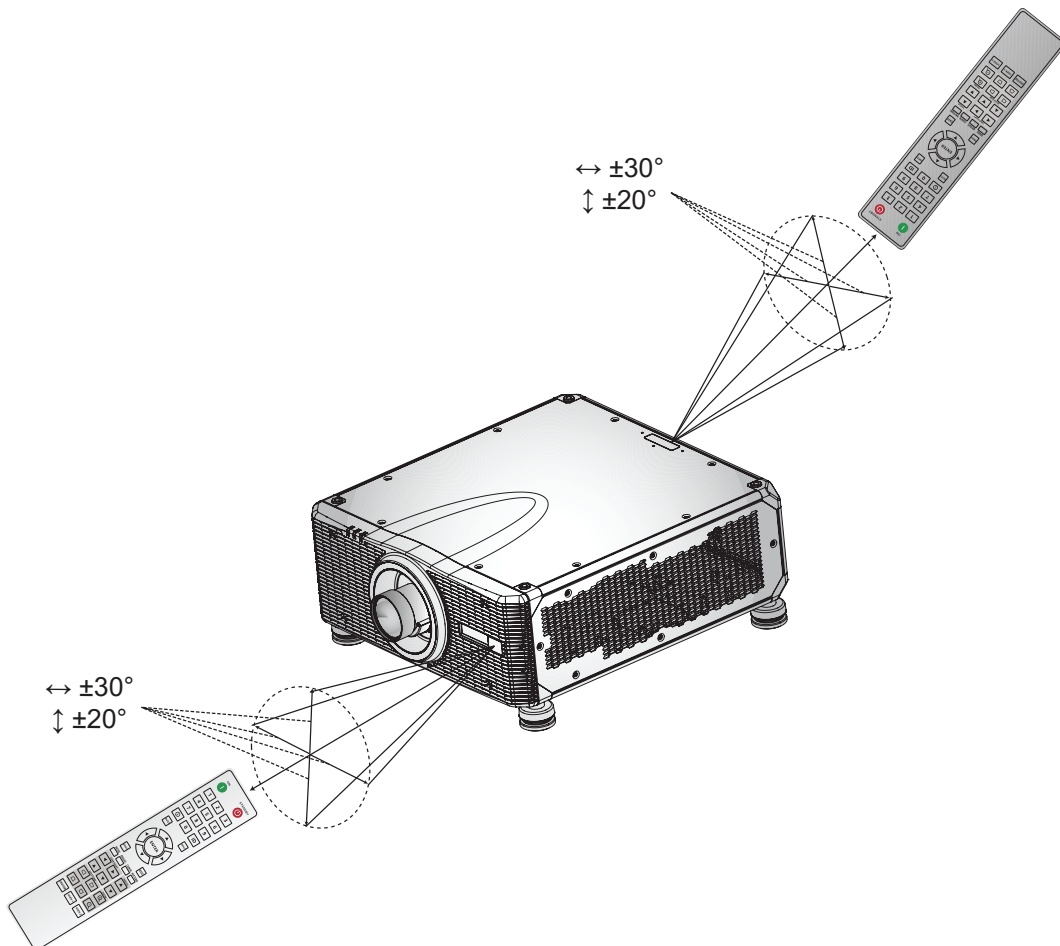

Image 3-20

## 3.8 Software update



**CAUTION:** Do not power off or unplug the projector while the software update is ongoing.

### How to update the software using the web interface.

1. Power on the projector.
2. Download the latest firmware file ( format .iso) from Barco's website. The firmware can be downloaded for free from Barco's website, (URL: <http://www.barco.com>). Click on *myBarco* and log in to get access to secured information. Registration is necessary.

If you are not yet registered, click on *New to myBarco* and follow the instructions. With the created login and password, it is possible to log in where you can download the software.

3. Connect your computer to the projector, using a LAN cable.
4. Browse to the IP address of the projector (e.g. the default 192.168.1.100).

The login screen will be displayed.

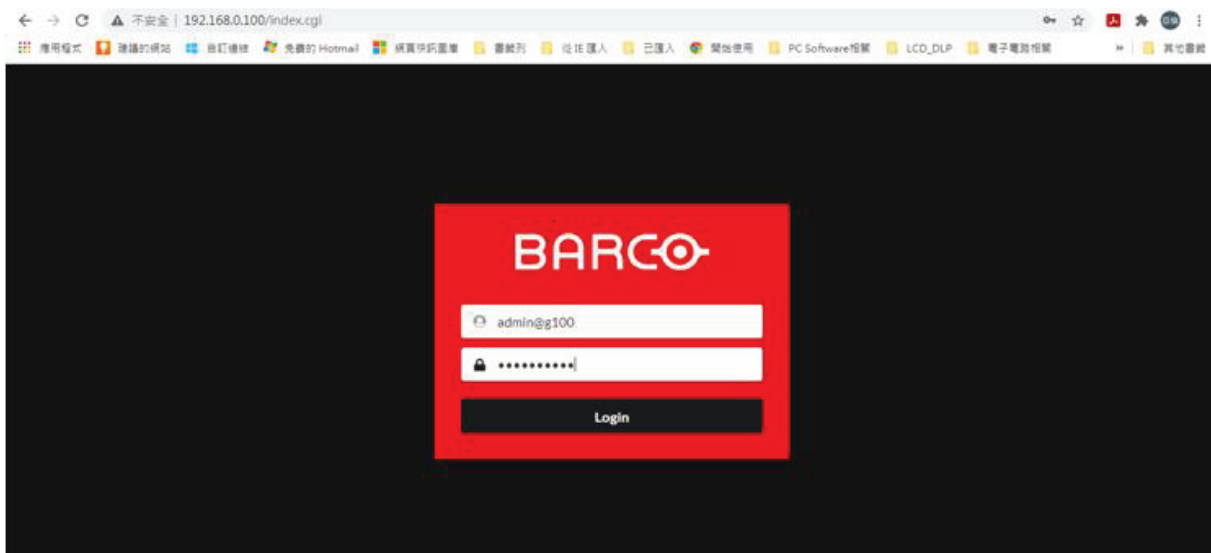

Image 3–21 Example of the login page

5. Log in, using the following (default) settings:

- Username: admin@g100
- password: admin@g100



*Tip:* It is advised to change the username and password once you have logged in. It is also advised to use a strong password.

6. Navigate to System Settings > Upgrade (reference 1).

The upgrade page will be displayed.

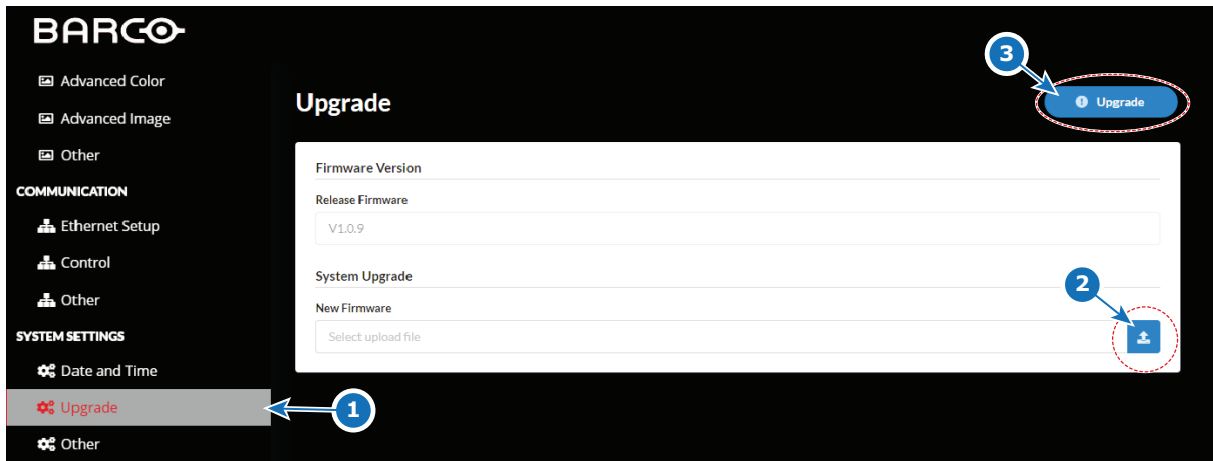

Image 3–22 Example of the upgrade page

7. Browse to the desired update package (format .iso) and confirm (reference 2). Click **Upgrade** (reference 3) to start the upgrade process.

The update file will be transferred to the projector and installed. The projector will reboot when completed.



Take note that the update process can take a long time to complete.



# UST lens

# 4

4.1	About the UST lens.....	58
4.2	Parts indication.....	60
4.3	Adapting the lens for the projecting position .....	61
4.4	Mounting the lens adapter .....	63
4.5	When mounting the lens without the support.....	65
4.6	Mounting the UST lens.....	66
4.7	Lens adjustment.....	70



**CAUTION:** When mounting the lens without the support, **always** use a safety cable as shown in the image.

## 4.1 About the UST lens

### Possible mounting positions

This lens can be mounted on the G100 series of projectors and can be mounted in two positions: facing upwards and to the left. The motor housing must be turned to the correct position before the lens is mounted in the projector.

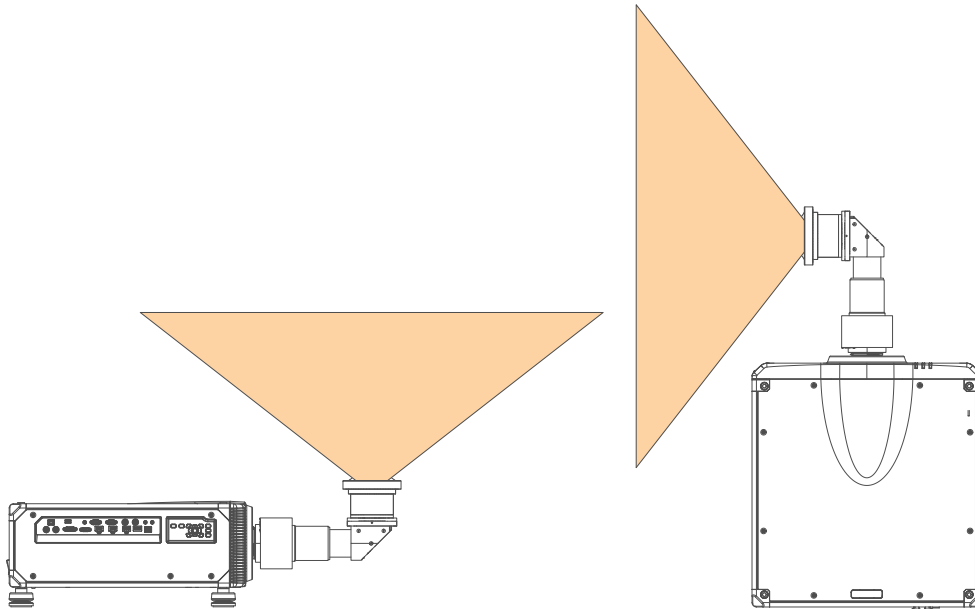

Image 4-1

### How your image is displayed

Projection to the side for any projector:

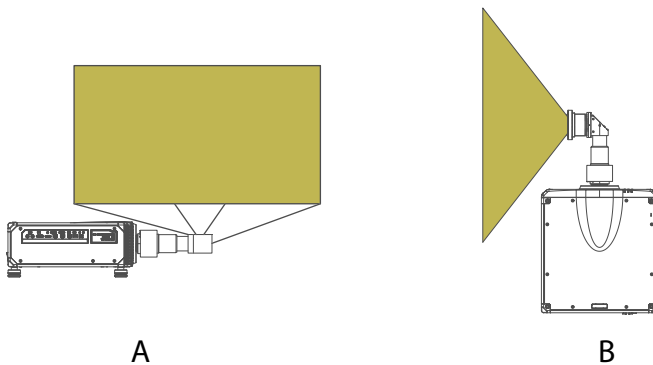
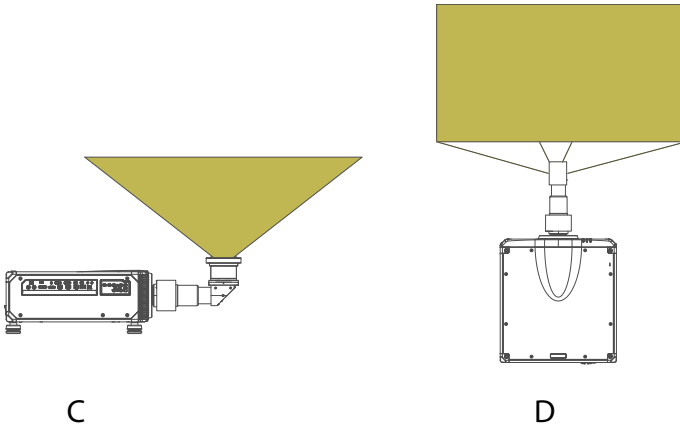

Image 4-2

- A** Side view
- B** Top view

Up projection for any projector:





C  
Image 4-3  
C Side view  
D Bottom view

## 4.2 Parts indication

### UST Lens adapter kit

The UST lens adapter kit for the G100 includes an adapter cover, hook and 7 hex screws. The cover and hook slide into each other as depicted in the following illustration.

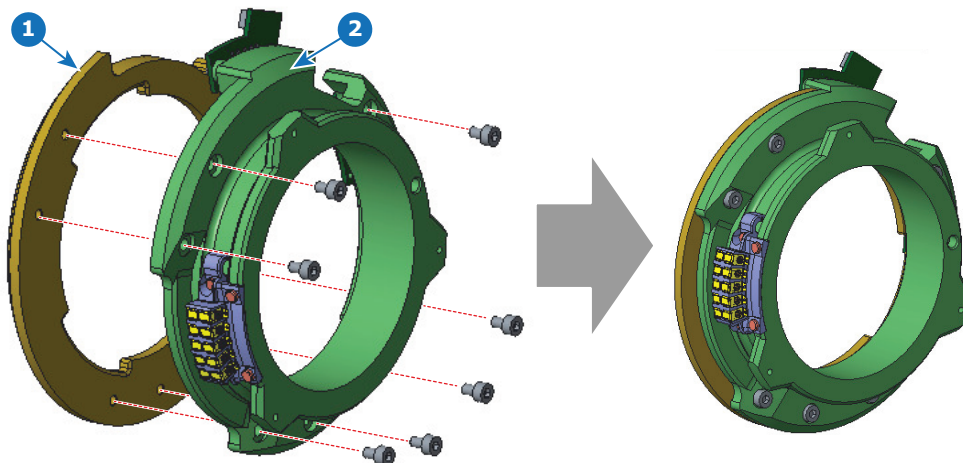

Image 4-4

- 1 UST-adapter cover
- 2 UST-adapter hook

### Lens support frame kit

The UST lens support kit for the G100 includes 3 mechanical parts and some screws. These parts are the following:

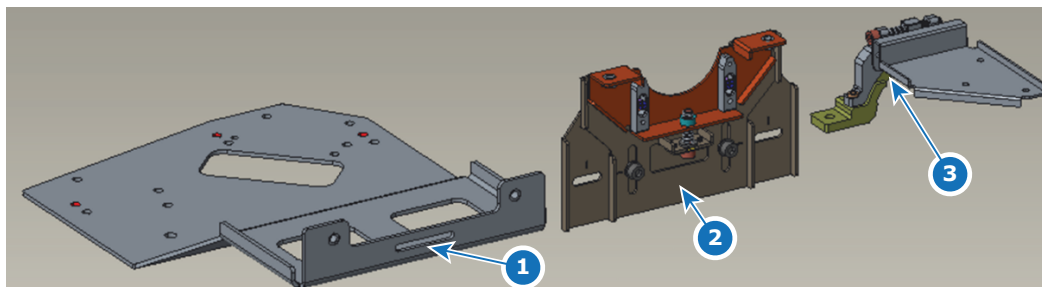

Image 4-5

- 1 Base plate
- 2 Lens holder module
- 3 Lens clamp module

## 4.3 Adapting the lens for the projecting position

### Required tools

Allen wrench with long shaft 2 mm

### How to adapt

1. Place the lens on a table. Turn out the 6 screws (1). Use an Allen key with a long shaft so that you do not damage the screw head. These screws will not be reused.

 **Note:** Always use the correct tool (delivered with the kit) to avoid damage to the screw heads !



Image 4-6

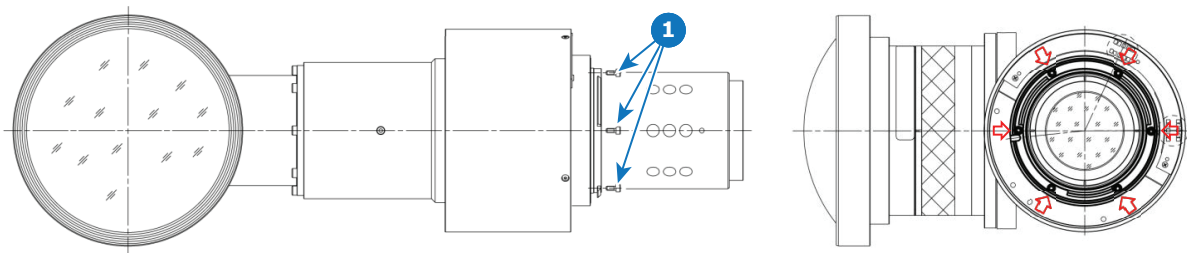

Image 4-7

2. Slide the motor housing a few mm to the backside of the lens (2) to disengage focusing gear and motor gear.

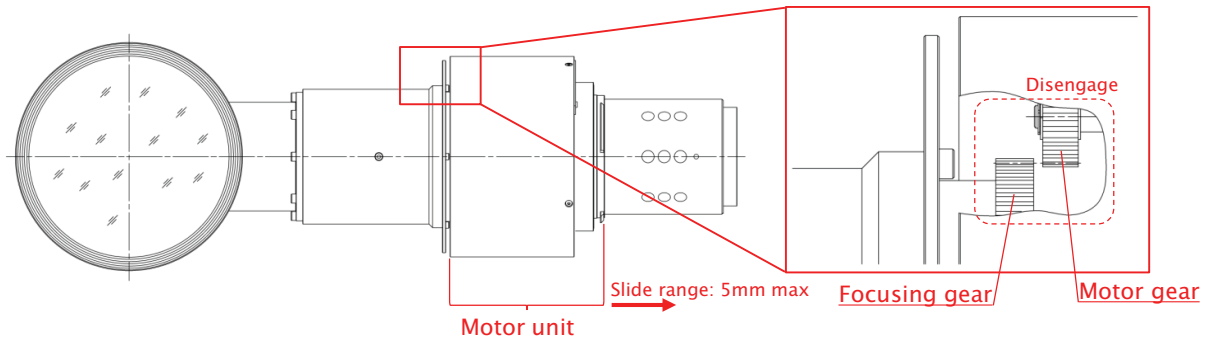

Image 4-8

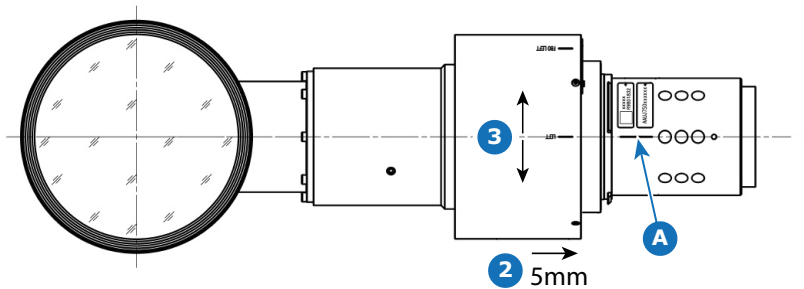

Image 4-9

**A** reference marking

3. Rotate the motor housing until the chosen marker on the housing corresponds with the reference marking on the lens body (steps of 30°). See if the mounting holes matches the holes in the lens body.

E.g. if you want to project to the left, then turn the motor housing until the left marking on the motor housing corresponds with the reference marking on the lens housing.

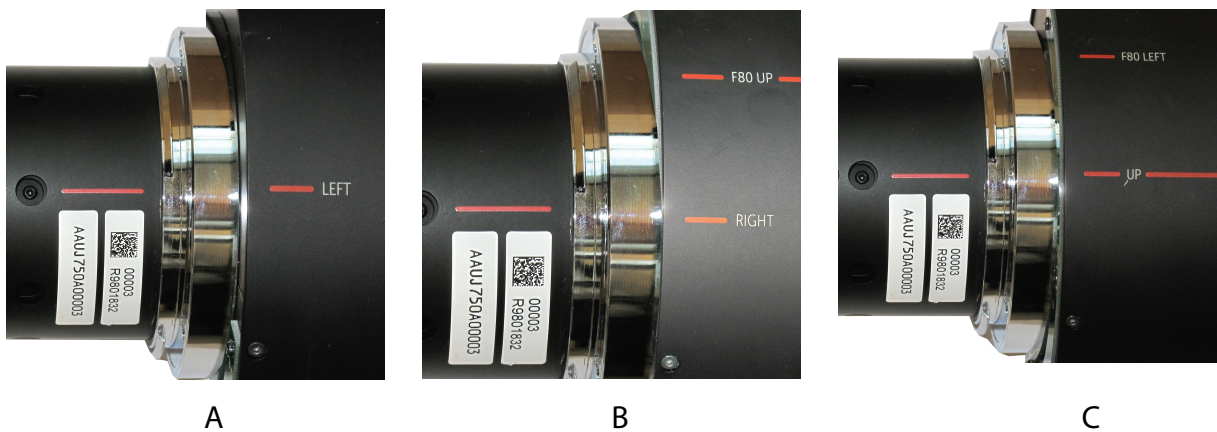

Image 4-10

- A** Project LEFT
- B** Project RIGHT (not used on G100)
- C** Project UP

4. Slide the motor housing back to the front of the lens to re-engage focusing gear and motor gear.
5. Drive in 6 **new** Allen screws with glue (screws are delivered with the kit). These screws can be multiple times reused. The turned out old screws can be thrown away.

Use again a tool with a long shaft (Allen wrench 2 mm, delivered with the kit).

The lens is ready to be mounted on the projector.

## 4.4 Mounting the lens adapter

### How to mount

1. Slide the UST-adapter-hook onto the lens input side until it matches the bayonet flang.
2. Secure the adapter hook by turning it clockwise (bayonet fitting).

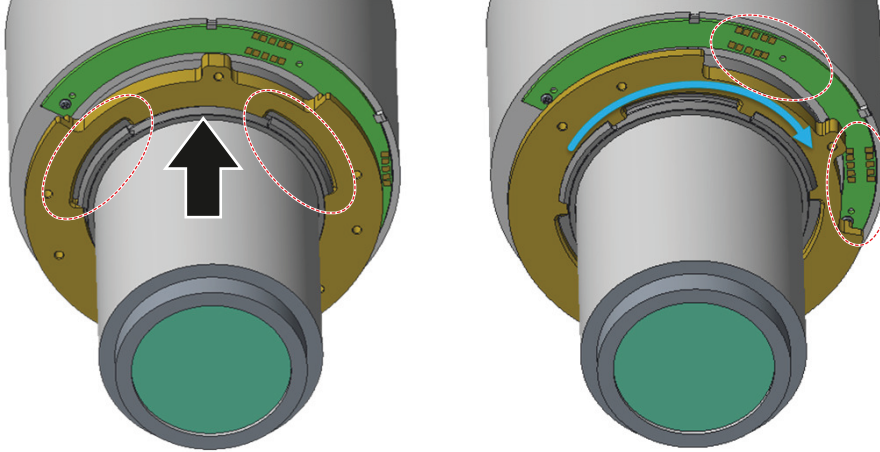

Image 4–11



*Tip:* Make sure that the contact points (C) of the lens are not covered by the adapter hook.



Image 4–12

**C** Contact points

3. Slide the UST-adapter cover onto the lens input and over the adapter hook as illustrated. Make sure the contact points of the cover touch the contact points of the lens.
4. Fasten the adapter cover and hook, using the 7 hex screws provided in the kit.

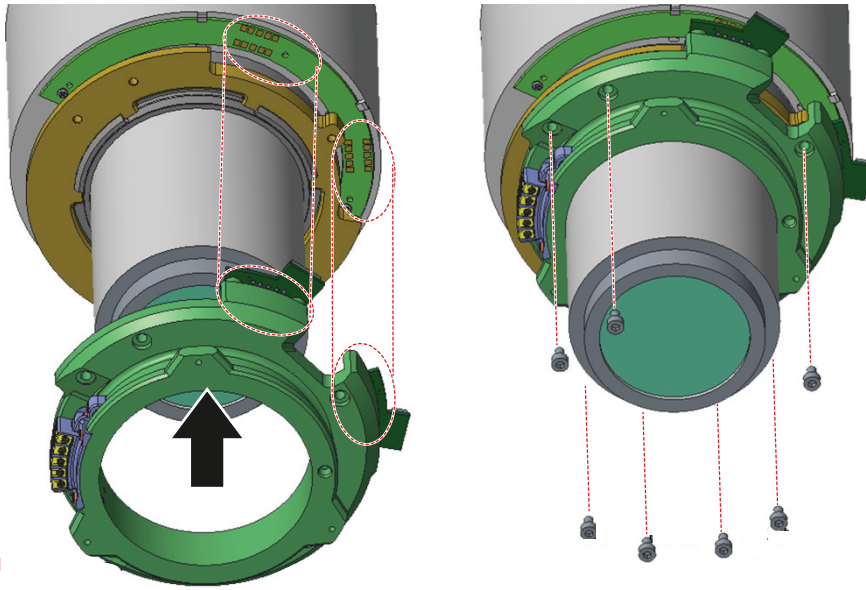

Image 4-13

## 4.5 When mounting the lens without the support

### When to use the safety cable

While it is strongly recommended to use the specifically designed mounting support for this lens in combination with this lens, it is not mandatory.

When mounting the UST lens in a projector without using the mounting support (not recommended), it is strongly advised to use the safety cable set provided by Barco instead. Failing to use either the correct type of safety cable or the mounting support may damage the lens and/or projector.

### How to prepare the lens with the safety cable

1. Stick 3 to 4 clips on the surface of the lens body (1).
2. Snap the first loop end of the safety cable into one of the clips.

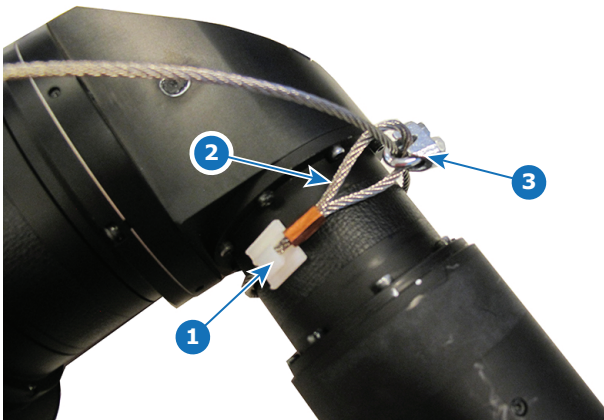



Image 4-14

3. Slide the rest of the cable around the lens. Click the cable into every clip it passes in the loop.
4. Slide the cable through the loop end at the beginning of the cable (2).
5. Install an U-bolt on the lens holder with the open ends oriented outwards (3). Make sure that both a part of the loop end and the outgoing part of the safety cable are placed in the enclosure.
6. Close the U-bolt and tighten it.
  -  *Note:* Make sure the safety cable is tightened around the lens before tightening the U-bolt nuts.
7. Place the shackle through the free loop end of the safety cable.
8. Mount the lens in the projector.
9. Secure the safety cable around the truss and secure the shackle by turning the safety ring of the shackle over the open end.



## 4.6 Mounting the UST lens



It is not recommended to use the UST lens in a dual setup when the projectors are mounted in their rigging frame.

### Required tools

- Allen wrench 5 mm
- Allen wrench 3 mm

### Required parts

- Base plate
- Lens holder module
- Lens clamp module
- Hex screws M6 (x3)

### How to mount?

1. Turn the projector on its top cover.
2. Place the bottom support plate on the bottom plate of the projector as illustrated. Make sure that the fixation holes match the holes in the bottom plate.

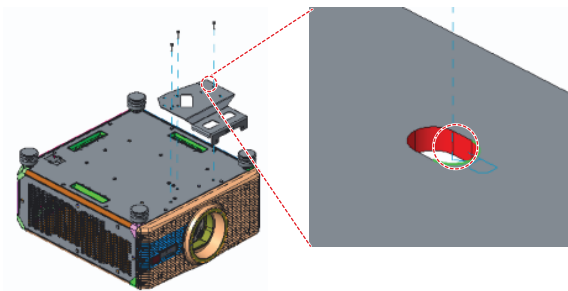

Image 4–15 Mount bottom plate on the front side of the projector



*Tip:* The blue circle is the ideal screw location

3. Drive in the three M6 screws. Use a 5 mm Allen wrench.
4. Turn the projector back on its feet.



*Note:* If the projector is to be mounted in the rigging frame, do this first. For more information, see the installation manual of the G100.

5. Carefully insert the lens into the lens holder.

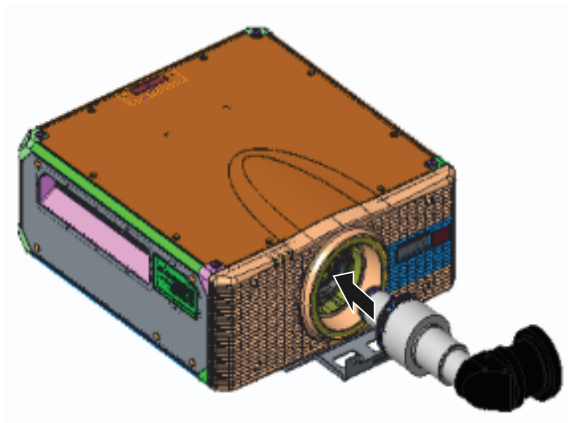

Image 4–16



6. Slide the lens holder module onto the base plate.
7. Drive in the screws partially, but do not fasten yet! It must be possible to move the plate a little bit while mounting the other plates.

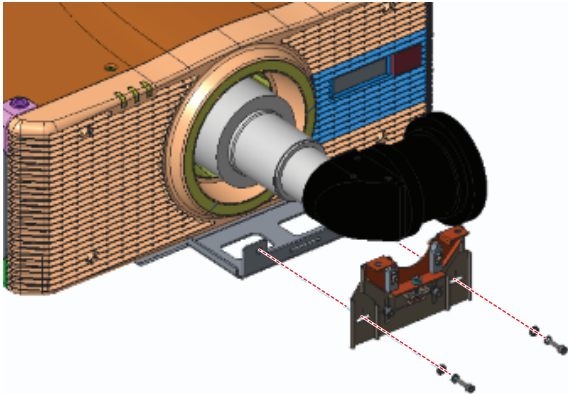

Image 4-17

8. Mount the lens clamp module onto the lens holder module, using screws and washers..

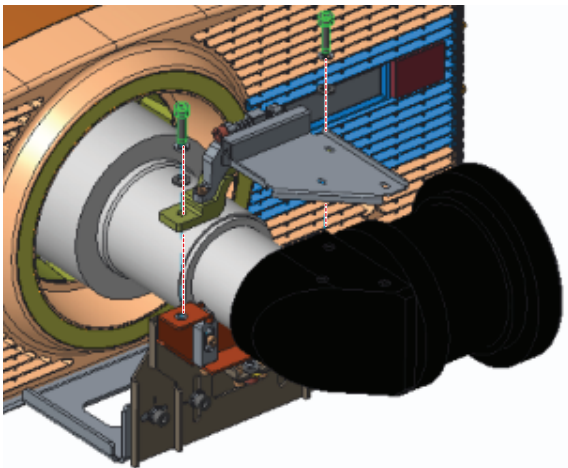



Image 4-18

 *Tip:* Adapt the lens clamp module, depending on how the lens has been mounted. If the lens points to the left, use the full lens clamp. If the lens points upward, only use the bottom part.

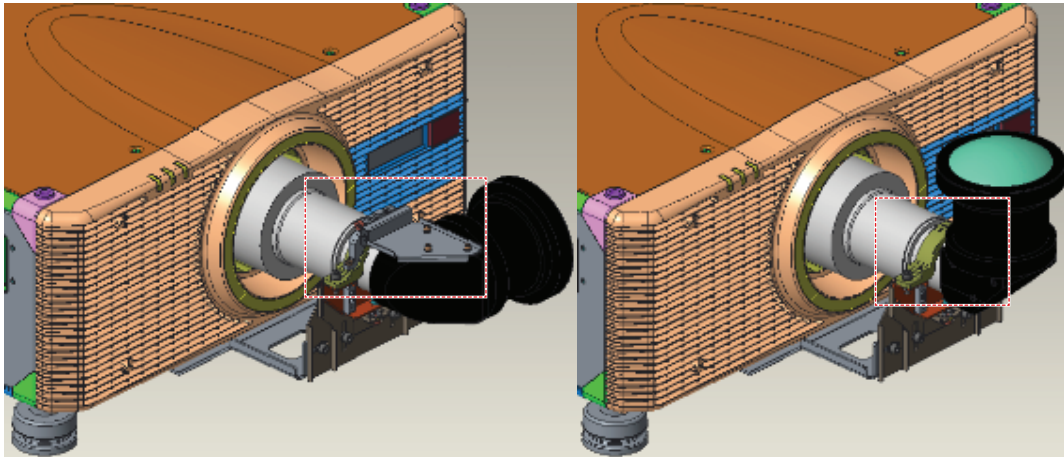

Image 4-19

Use a 3 mm Allen wrench to release the 3 screws holding the parts together

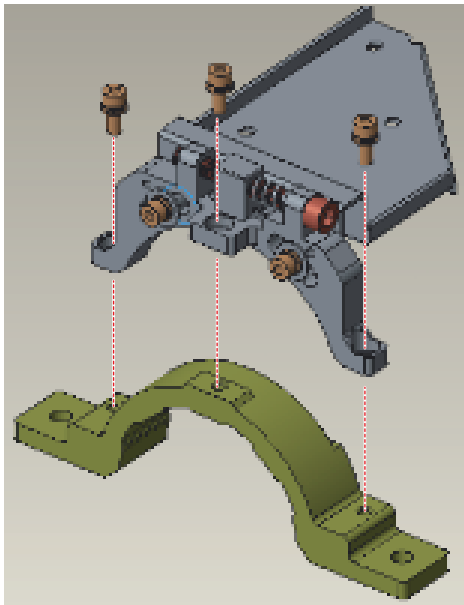

Image 4-20

9. In the case the lens points to the left side of the projector, you can also secure the lens and adapter plate with 3 hex screws.

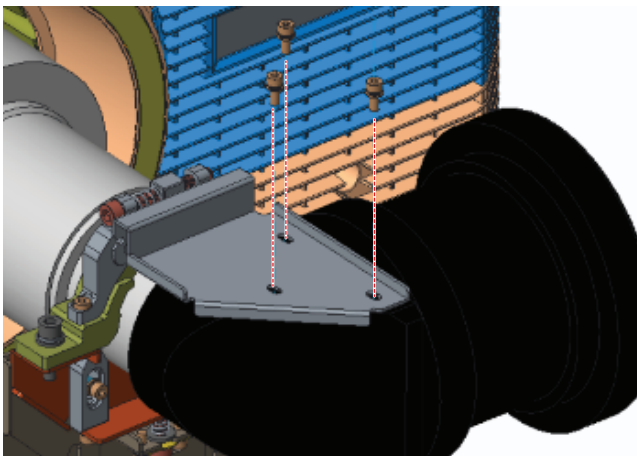

Image 4-21

**10.** Is the projector installed above the head of people?

- ▶ If **yes**, install the lens safety cable. See chapter [“Installing the lens safety cable”](#), page 43.

## 4.7 Lens adjustment

### Read this first when using the UST lens with the G100 rigging frame (R9802681)



It is not recommended to use the UST lens in a dual setup when the projectors are mounted in their rigging frame.

- When the UST lens is combined with the G100 rigging frame (R9802681), a minimum lens shift is required to avoid shadows.
- Relative to the center position the lens needs to be shifted upwards by a minimum of 10%, and to the right by a minimum of 25%. (100% = half the image height/width)
- The removable front bar of the frame should also be removed. For how to remove this bar, see documentation which is included in the packing of rigging frame.

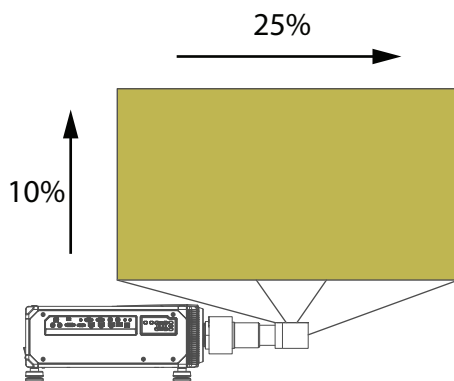

Image 4-22



**CAUTION:** When lens shift has to be used, loosen screws 1, 2, 3 and 4 (Image 4-23) before starting with this lens shift and that to avoid damage to the shift motors and lens holder.

### Location of the adjustment screws

Before adjusting the lens, make sure that screws 1–4 on the adapter are not tightened, and that screws 5 and 6 are in mid position.

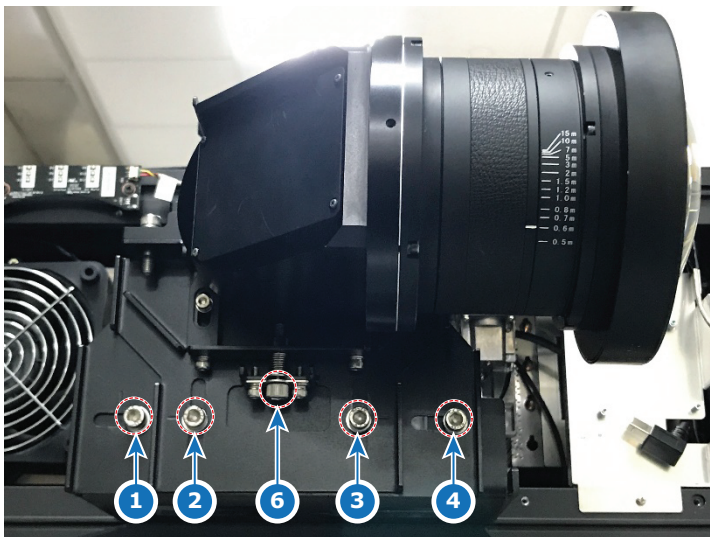
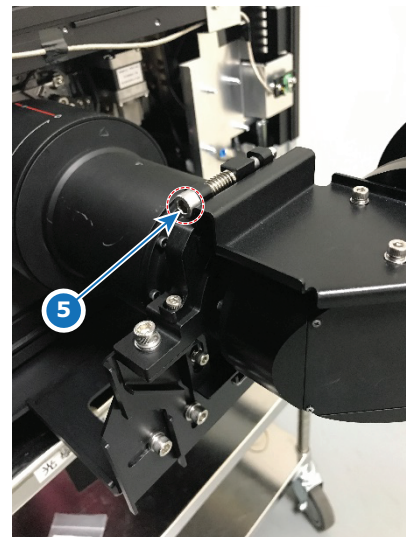

Image 4-23



- 1 Screw for horizontal shifting
- 2 Screw for vertical shifting
- 3 Screw for vertical shifting

- 4 Screw for horizontal shifting
- 5 Tilt adjustment screw
- 6 Focus adjustment screw



## How to adjust the lens

1. Shift the lens to the desired position as much as possible using the lens holder and software. Adjust with hand if necessary.

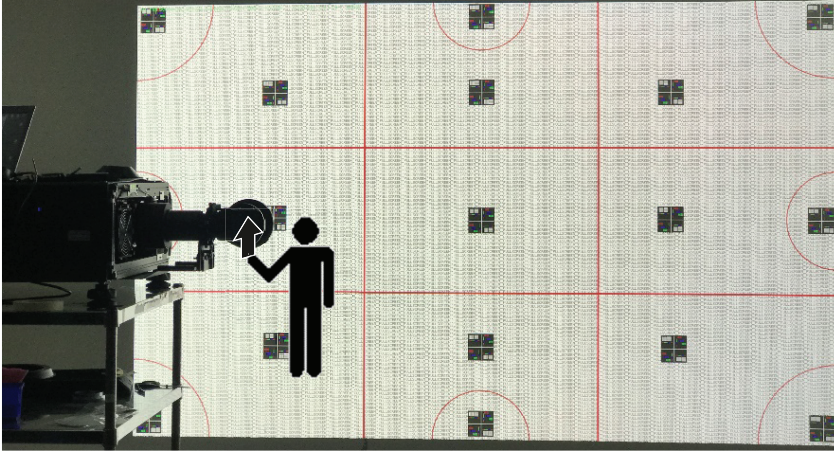

Image 4-24

2. Once the desired position has been reached, tighten the vertical shifting screws (2 and 3).
3. Fine-tune the tilt of the projected image, using screw 5. Using this method, you can adjust  $\pm 7.5^\circ$ .

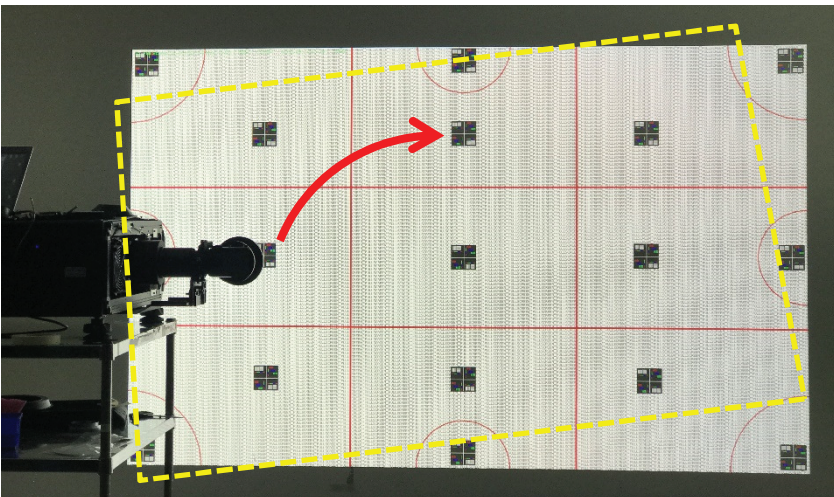

Image 4-25



*Tip:* Turning screw 5 clockwise will tilt the image counterclockwise. Turning the screws counterclockwise will tilt the image clockwise.

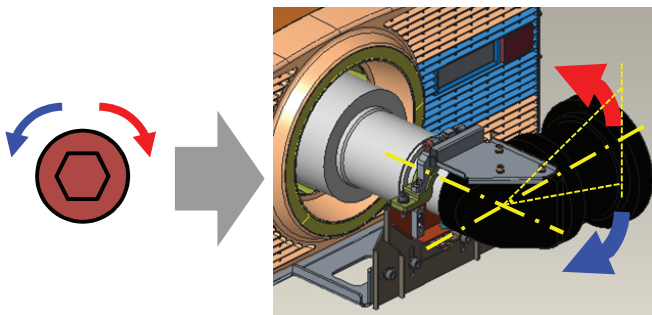

Image 4-26

4. Fine-tune the focus of the projected image vertically, using points A and B on the following image as reference points. The resolution/balance between both points should be the same.
  - Use the focus software feature to help focus the image.
  - Use adjustment screw 6 to help focus the image.

- Use the focus ring at the end of the lens to help focus the image.
- If necessary, loosen screws 2 and 3 a bit to push the lens a bit upward or downward to spot any variation in image quality.

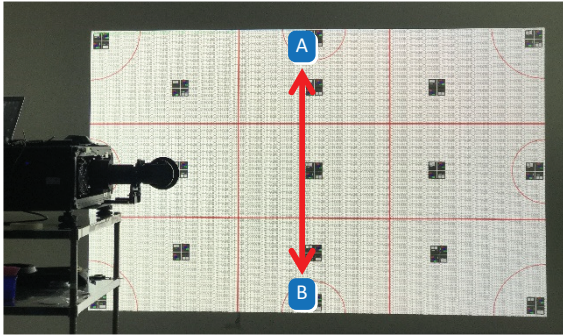

Image 4-27

5. Fine-tune the focus of the projected image horizontally, using points C and D on the following image as reference points. The resolution / balance between both points should be the same.
  - If the balance is a bit off, gently move the lens horizontally to see if this makes any difference.
  - Use the focus ring at the end of the lens to help focus the image.

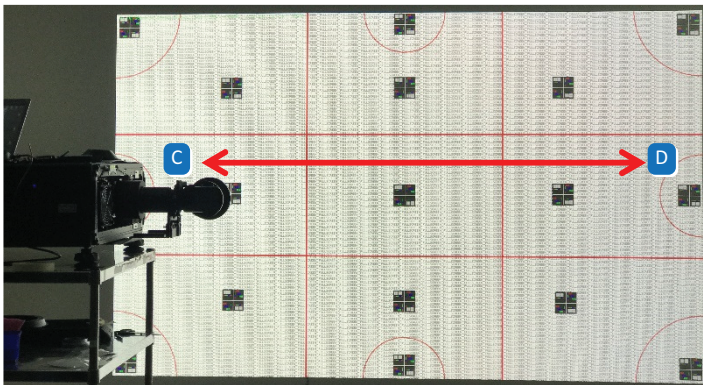

Image 4-28

6. Once shift, tilt and focus is all as desired, tighten adjustment screws 1 – 4.
7. Have a final check, using the focus feature and the focus ring of the lens. Repeat all previous steps if the end result is not as desired.

# Powering on/off the projector

# 5

5.1	Powering on the projector.....	74
5.2	Powering off the projector.....	75

## 5.1 Powering on the projector

### How to power on the projector

1. Power on the AC switch (1) and wait until the power button on the control panel is solid orange.

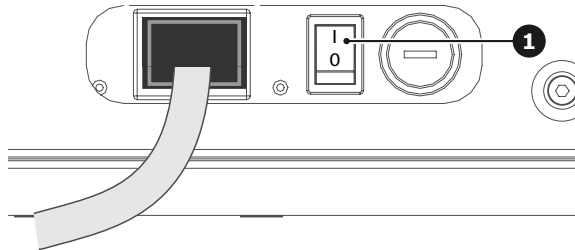

Image 5-1

2. Turn on the projector by pressing the POWER button (2) on the control panel or the ON key (3) on the remote control.

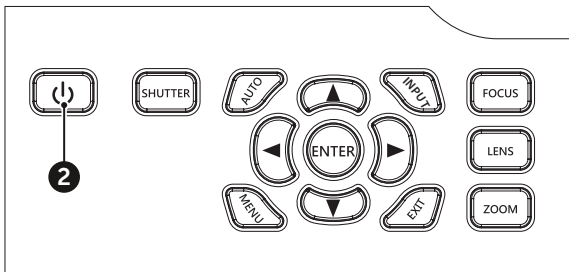

Image 5-2

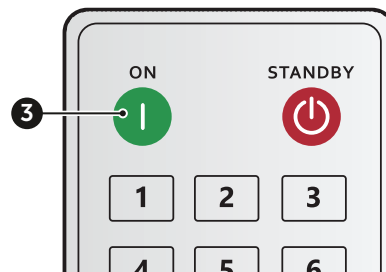

Image 5-3

The status LED (4) will flash orange. The startup screen will display and the status LED will turn to solid green.

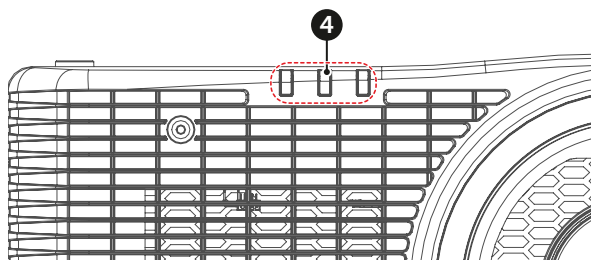

Image 5-4

3. Turn on your source. The projector detects the source you selected and displays the image.



*Note:* If you connect multiple sources at the same time, press “Input” key on the control panel or on the remote control to switch inputs.



If this is the first time you powered up the projector, you will be prompted to select the projector language, projector orientation and other basic settings.



**WARNING:** Do not look directly into the lens when the projector is turned on. The strong light might cause permanent eye damage.



## 5.2 Powering off the projector

### How to power the projector off

1. Press the POWER button (2) on the control panel or the OFF key (5) on the remote control.  
A message will be prompted on screen to confirm if you want to turn off the projector.
2. Press the POWER button or OFF key again to confirm. If not, the message will disappear after 10 seconds and the projector will remain on.  
The projector will go to standby mode.
3. Once the projector has entered standby mode and you want to turn the projector off completely, power off the AC switch.



*Tip:* If you still plan to use the projector in the foreseeable future, it is recommended to keep the projector in standby mode. Only turn off the projector completely if you want to physically move the projector, or if you do not plan on using the projector for the foreseeable future.



**CAUTION:** It is not recommended to turn the projector on immediately after powering off the projector.



# Dimensional drawings

# A

A.1	Dimensions of the projector .....	78
A.2	Ceiling mount information.....	79

# A.1 Dimensions of the projector

## Overview

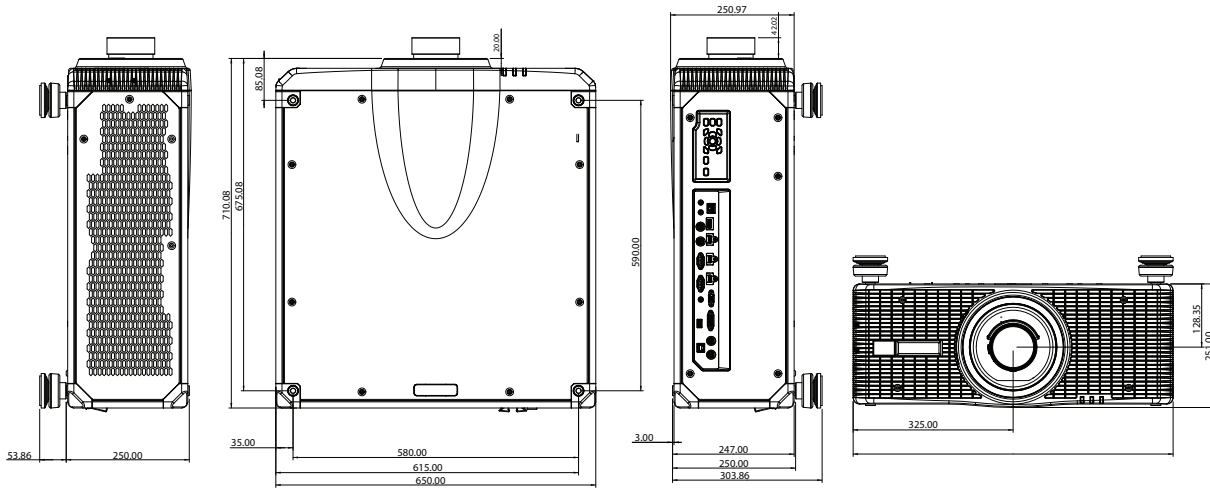

Image A-1

## A.2 Ceiling mount information

### Projector dimensions

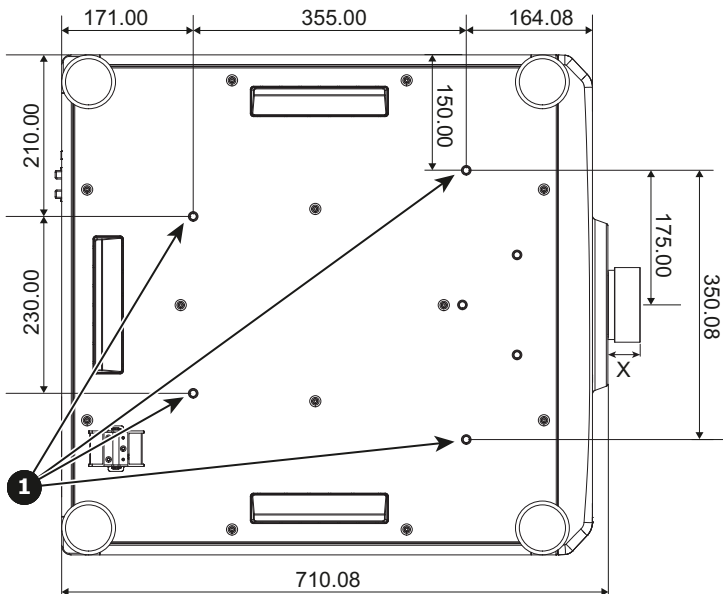

Image A-2 All dimensions given in mm

- 1** Mounting holes for ceiling mount
- X** Distance between projector and end of lens

Lens type	Distance X (in mm)
R9802188	82.94
R9802181	53.12
R9802182	56.42
R9802183	56.79
R9802184	42.02
R9802185	76.23
R9802186	106.9
R9802187	143.32

### Ceiling mount information

To prevent damage to your projector, please use a Barco recommended ceiling mount. Ensure the screws used to install the mount to the projector meet the following specifications:

- Screw type: M8 x 4
- Minimum screw length: 18 mm



Damage resulting from incorrect installation will void the warranty.



# Index

## B

Boresight  
Adjustment 47  
Box content 24

## C

Ceiling mount 79  
Control panel 29  
Cooling requirements 22

## D

Dimensions 79  
Projector 78  
Download  
Projector Toolset 38

## E

Electrical shock 10  
Enclosed projection 17  
Environment conditions 22

## F

Fire hazard 11

## G

General considerations 15  
Safety 8

## H

Hazard Distance 15, 17  
Hazardous Chemicals 13  
HD for G100 Series

Safety 9  
High Brightness precautions 15

## I

ID 52  
Info tri 19  
Initial inspection  
Box content 24  
Input/Output 28  
Install  
Lens 42  
Procedures 39  
Installation preparations 21  
Installation requirements 22  
Clean air 22  
Environment conditions 22  
Instructions  
Safety 10

## L

Labels  
Safety 14  
Safety G100 14  
Laser safety precautions G100 Series  
Safety 8  
Lens  
adjustment 70  
Boresight  
Adjustment 47  
Overview 58  
Preparation 61  
Safety cable 43  
Scheimpflug  
Adjustment 47  
Lens adapter  
Mount 63  
Lens offset 36  
Lens selection 32  
Lens specifications 33  
Lenses 33

Lens selection 32

## M

Mechanical check 24  
Mounting  
  Lens 66  
  Safety cable 65

## N

Notice on safety 8

## O

Off axis 36  
On axis 36  
On/Off 73  
Overview 30

## P

Parts 60  
Personal injury 10  
Physical Installation 39  
Position 31  
Power 73  
Power cord 41  
Power off 75  
Power on 74  
Procedures  
  Install 39  
Projector  
  Components 25  
Projector Address 52  
Projector damage 11  
Projector Toolset 38

## R

RCU  
  Battery 40  
Rear projection 17  
Regulatory 19  
Remote control  
  Usage 53

## S

Safety 7  
  Battery explosion 12  
  General considerations 8  
  Hazard Distance 15, 17  
  Hazardous Chemicals 13  
  HD for G100 Series 9  
  Instructions 10  
  Labels 14  
  Labels G100 14  
  Laser safety precautions G100 Series 8  
  Prevent electrical shock 10

Prevent fire hazard 11  
Prevent personal injury 10  
Prevent projector damage 11  
Safety Data Sheet (SDS) 13  
  Servicing 12  
  User definition 9  
Safety cable  
  Lens 43  
Safety Data Sheet (SDS) 13  
Scheimpflug 47  
  Adjustment 47  
Scheimpflug's law 47  
Shift range 36  
Software update 54  
Specifications 77

## U

UK Compliance 19  
User definition  
  Safety 9  
UST lens  
  Installation 57  
  Mounting 66

## W

WEEE 19







R5913458 /05 | 2022-08-30

[www.barco.com](http://www.barco.com)