

FS 12T-66

FS Series Arena Horn Loudspeaker



FS12T-66

Features

- Ideal for a Wide Array of Outdoor and Indoor Applications
- Integrated 400-Watt 70.7V Transformer
- Constant Directivity Design Offers Controlled Coverage of 60° Horizontal by 60° Vertical
- All-Weather Construction Ensures Long-Term Reliability Through Varying Seasons
- Flexible Mounting System Ensures Versatile Install Mounting Angles
- Easy Service Design Allows Transducers to be Serviced in the Field without Uninstalling the Enclosure from the Mount
- Neutral Finish Blends into Any Environment

Applications

The FS12T-66 features a lightweight and compact all-weather enclosure that can be used in multiple outdoor and indoor installation applications including arenas, stadiums, fairgrounds, racetracks, theme parks, outdoor entertainment centers, convention centers, aquatic centers, and multipurpose venues.

General Description

The FS12T-66 is two-way, full-range loudspeaker system engineered to provide excellent voice and music reproduction in applications requiring weather resistance. It was designed to withstand exposure to environmental conditions and provide long-lasting reliability.

It incorporates a 12" LF driver and 1" exit HF compression driver concentrically mounted to a high-directivity waveguide. It provides 60° x 60° coverage and is tuned for optimal source reproduction.

The unit is constructed using molded linear low-density polyethylene (LLDPE), creating an incredibly strong yet lightweight enclosure. The unit includes a stainless steel U-bracket and fly-points allowing for easy mounting. Input is via an integrated 70.7V transformer with low insertion loss and full frequency response with power taps up to 400-watts including an 4Ω bypass. The transformer is discretely mounted under the rear cover for weather protection. The finish is neutral "battle ship grey" that is UV resistant and allows for years of durability.

System	
Type	Full-Range, Outdoor, Horn Loudspeaker
Operation Mode	Non-Powered Passive
Operating Range (-10db)	57Hz - 18.6kHz
Frequency Response (+/- 5dB)	80Hz - 17.6kHz
Sensitivity (2.83V @1m)	102.5 dB
Vertical Coverage	60°
Horizontal Coverage	60°
Max Input Ratings (4 ohm)	400 W Continuous, 800 W Program
Transformer Taps - 70V	400W, 200W, 100W, 50W
Transformer Taps - 100V	400W, 200W, 100W
Directivity Factor (Q)	36.4 @ 4kHz
Directivity Factor (DI)	15.6 @ 4kHz
Max SPL at 1m (passive)	128.5
Crossover Frequency	1.1kHz
Recommended Signal Processing	70 Hz High Pass Filter
Recommended Power Amplification	400W @ 4Ω
Transducers	
LF Transducer Qty and Size	1 x 12"
LF Voice Coil Size	2.5"
MF Transducer Qty and Size	N/A
MF Voice Coil Size	N/A
HF Transducer Qty and Size	1 x Compression Driver 1" Throat
HF Voice Coil Size	1.75"
Maximum Output (System)	128.5 dB
Nominal Impedance (System)	4Ω
Minimum Impedance (System)	4.1Ω @ 1050Hz
Driver Protection	HF and LF Driver Protection Circuits
Enclosure	
Color	Light Gray
Enclosure Material	LLDPE (Linear Low-Density Polyethylene)
Grille Material	Aluminum
Baffle Material	N/A
Mount Material	Stainless Steel
Input Connection	Barrier Terminal, Transformer/ 4Ω Direct
Controls	N/A
Mounting/Rigging Provisions	6mm Stainless Steel U-Bracket
Ingress Protection	IP45 When Tilted 5° Downwards
Environmental Testing	MIL-DTL-12606
Cutout Diameter	N/A
Logo	2 Sides, Rear Cover, and Grill
Product Dimensions (HxWxD)	19.56" x 18.5" x 18.5" (497.84mm x 469.9mm x 496.9mm)
Shipping Dimensions (HxWxD)	24.5" x 23.5" x 23.5" (622.3mm x 596.9mm x 596.9mm)
Net Weight	48 lbs. (21.77 kgm)
Shipping Weight	60 lbs (27.21 kgm)
Warranty Coverage	
Warranty Period	5 Years

NOTES:

1. Sensitivity: 1 meter, 2.83 volts RMS.
2. Power: All power figures are calculated using the rated nominal impedance.
3. Frequency response and sensitivity are anechoic measurements.

©2016 Atlas Sound L.P. and Innovative Electronic Designs, LLC. All Rights Reserved. Atlas Sound is a trademark of Atlas Sound L.P. IED is a registered trademark of Innovative Electronic Designs, LLC. All other trademarks are the property of their respective owners. All specs are subject to change without notice. ATS005225 RevA 6/16

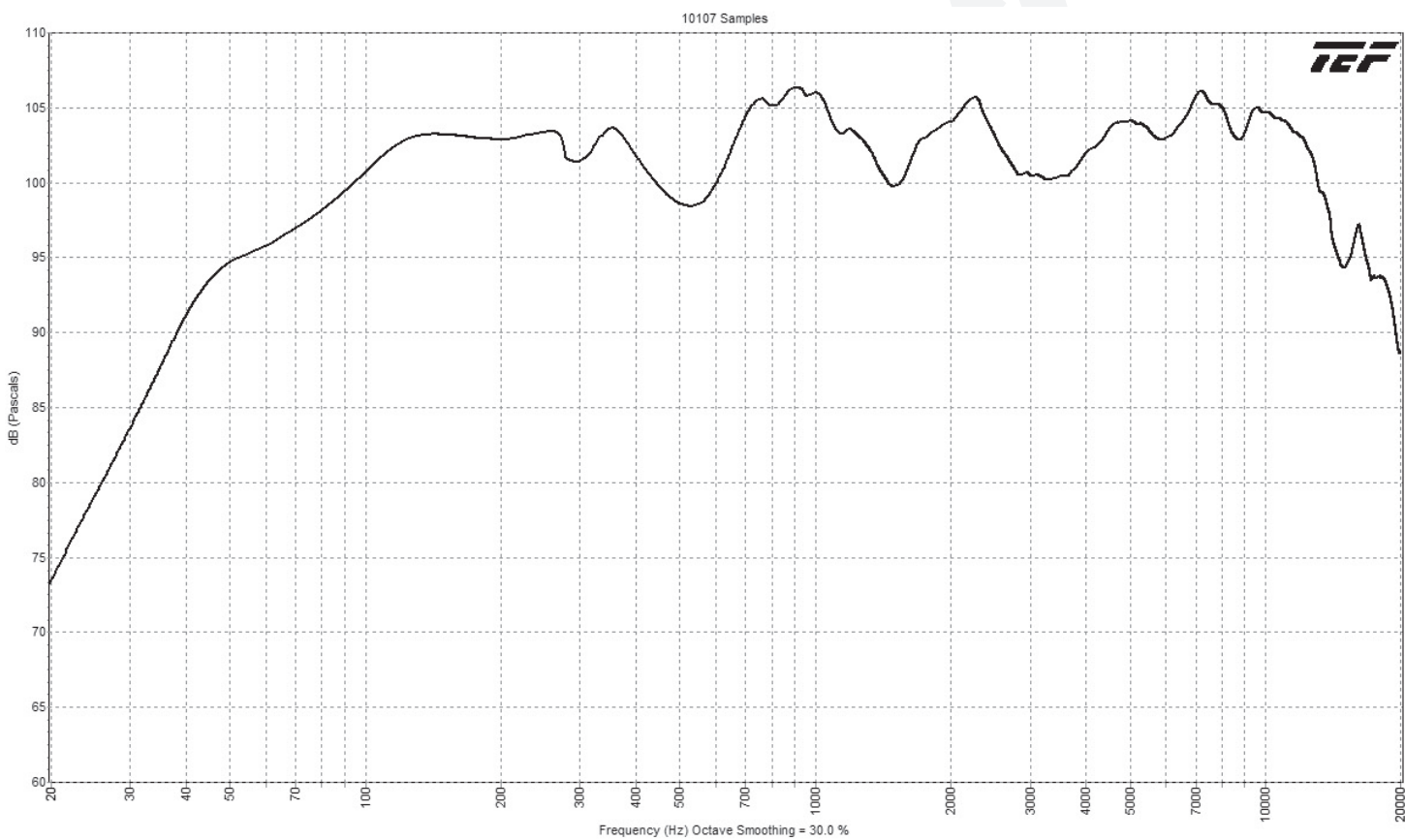
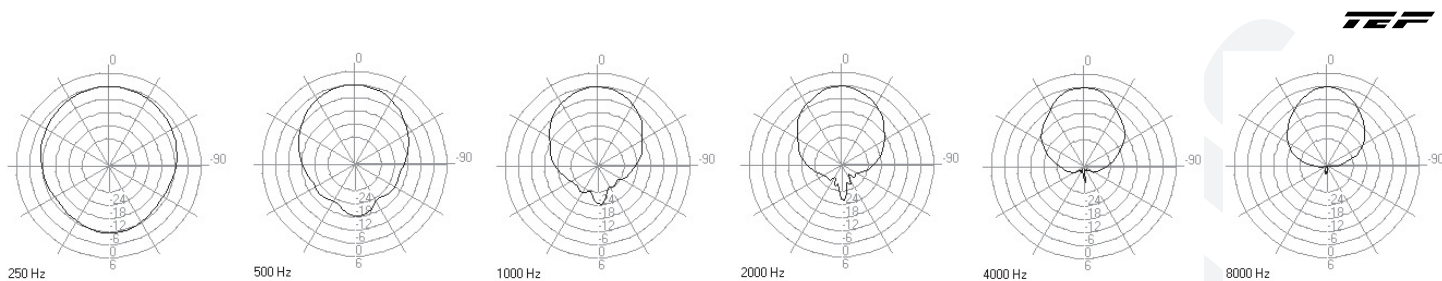

©2016 Atlas Sound L.P. and Innovative Electronic Designs, LLC. All Rights Reserved. Atlas Sound is a trademark of Atlas Sound L.P. IED is a registered trademark of Innovative Electronic Designs, LLC. All other trademarks are the property of their respective owners. All specs are subject to change without notice. ATS005225 RevA 6/16

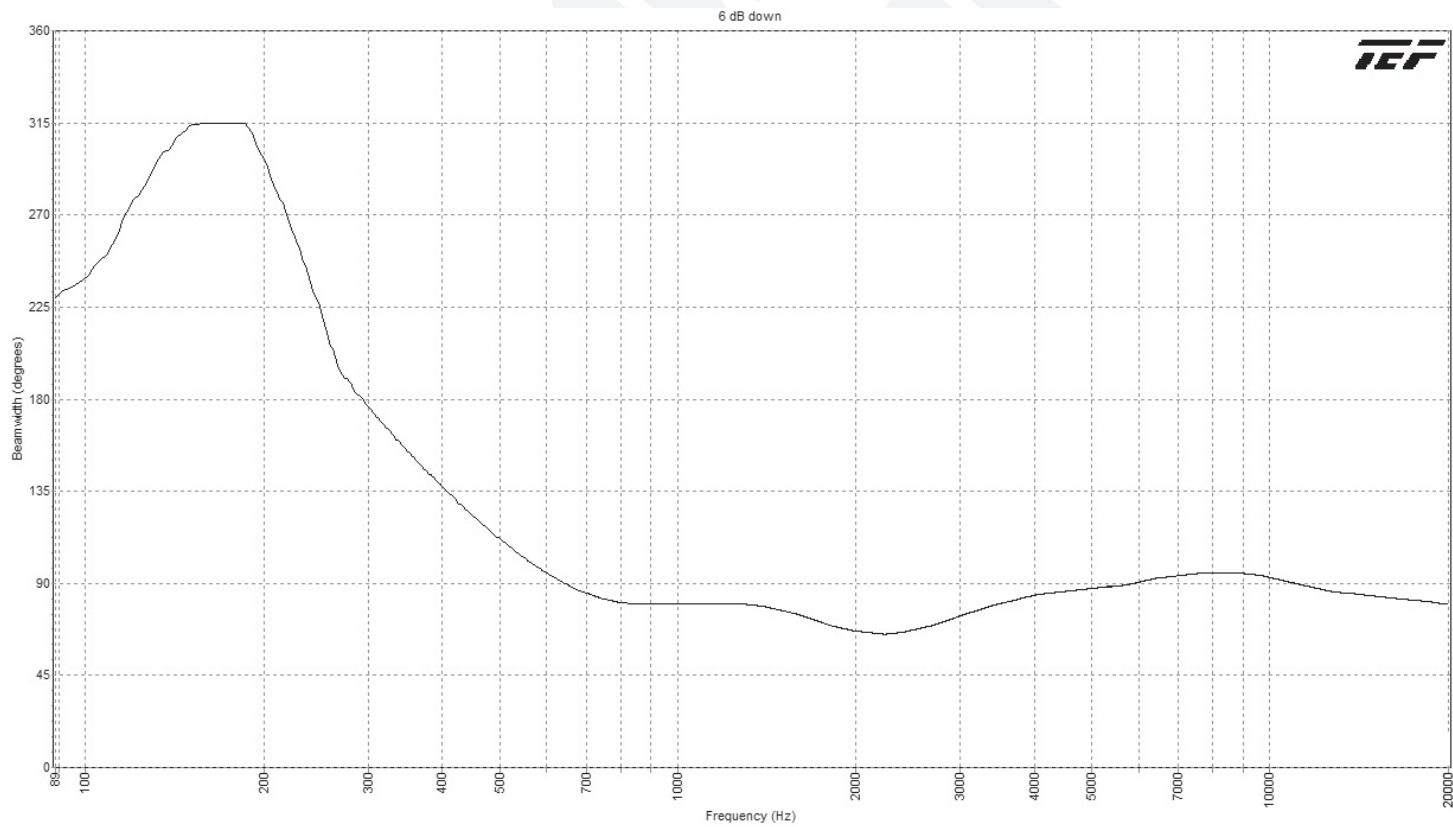
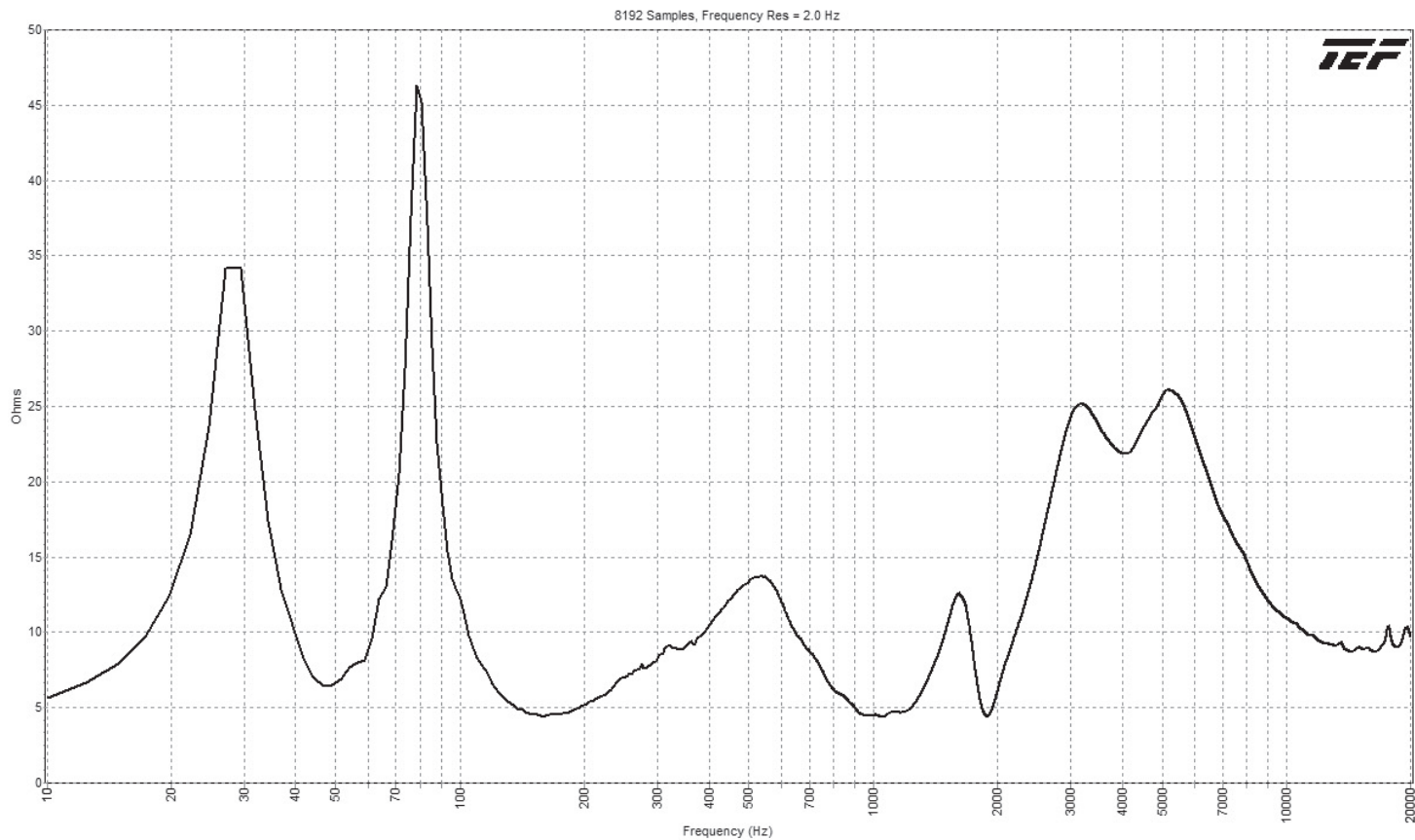

Dimensional Drawings

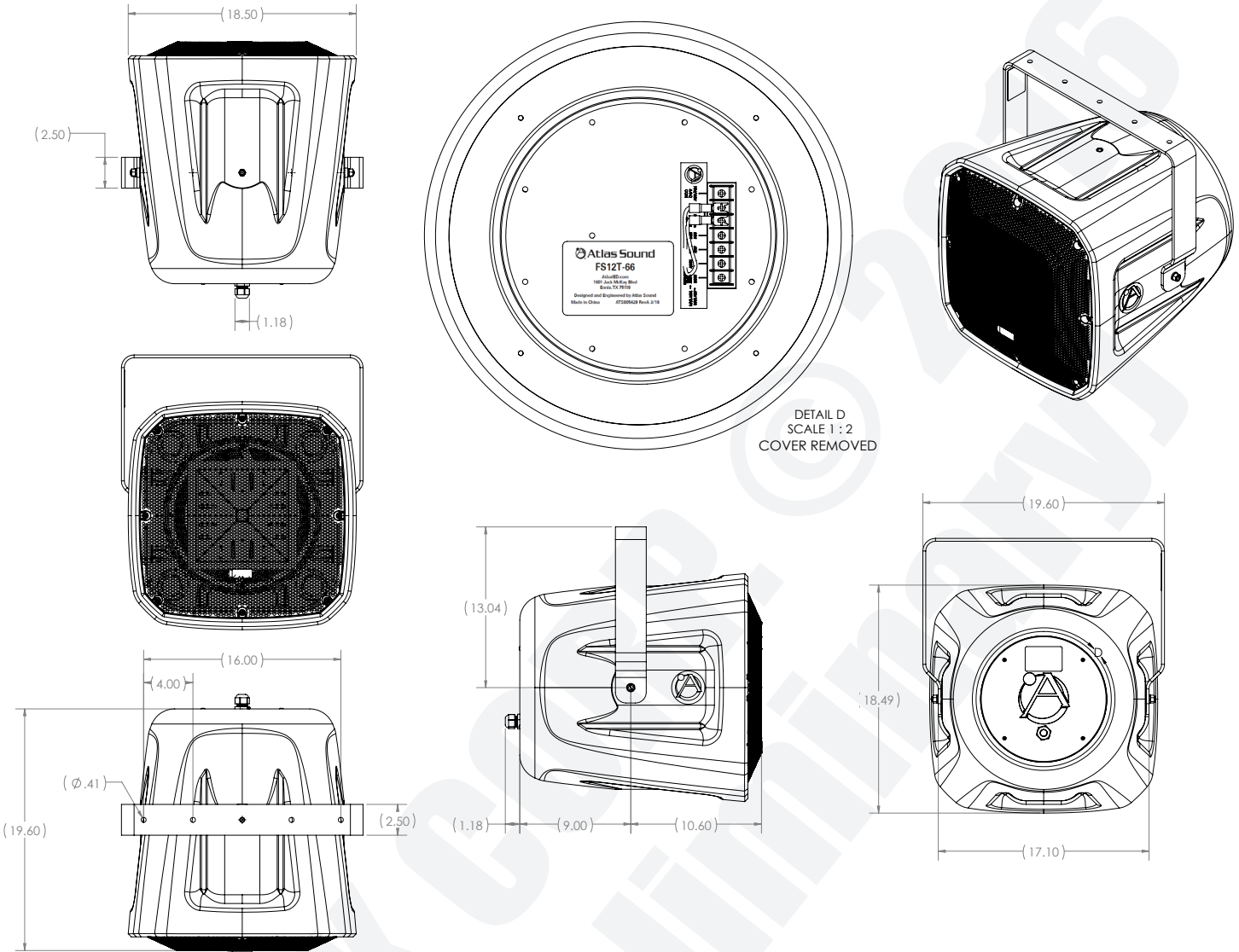

Angle Set Strap

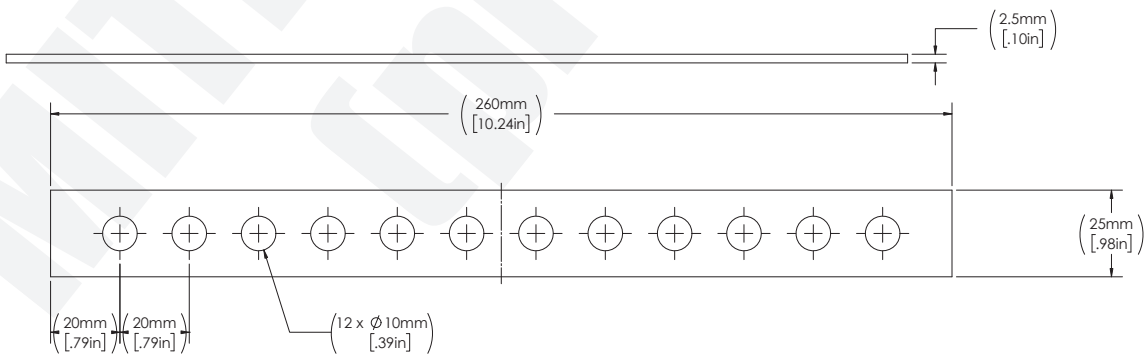

©2016 Atlas Sound L.P. and Innovative Electronic Designs, LLC. All Rights Reserved. Atlas Sound is a trademark of Atlas Sound L.P. IED is a registered trademark of Innovative Electronic Designs, LLC. All other trademarks are the property of their respective owners. All specs are subject to change without notice. ATS005225 RevA 6/16

Architect and Engineer Specifications

Loudspeaker shall be Atlas Sound model FS12T-66 or approved equal.

The loudspeaker system shall be a two-way, full-range design with an IP45 rating. It shall include a 12" cast frame LF woofer and an integral, concentrically mounted 1" exit compression driver coupled to a constant directivity high frequency waveguide. The three pole (18dB/octave) dividing network shall have a crossover frequency of 1.6kHz. The dividing network shall include a poly switch protection circuit for the high-frequency component.

The loudspeaker system shall be capable of providing a sound dispersion angle of 60° _horizontal by 60° _vertical in the 2kHz octave band. Rated power shall be 400 watts RMS based on EIA Standard RS-426B.

Enclosure shall be UV-resistant, linear low-density polyethylene (LLDPE) and shall include a 2-stage multiple mesh filter system for weather and rodent resistance: to include a 20-gauge perforated aluminum screen on front mouth assembly, a 100 x 100 weave stainless steel mesh between HF horn and HF driver and a 100 x 100 weave stainless steel mesh over 12" woofer. The loudspeaker shall include a stamped and formed, 2mm stainless steel powder coated mounting bracket assembly for surface mounting.

Sensitivity shall be 102.5dB SPL (80Hz to 15kHz in 1/3 octave bands) measured at a distance of one meter on axis with a one watt input half space (2.83V).

Overall frequency response shall be 80Hz – 17.6kHz. The input section located on the bottom rear of the loudspeaker shall be via 7 position screw down terminal strip internally configured to allow input to an internally mounted 70.7V transformer with 50, 100, 200, 400-watt taps and a bypass jumper direct coupled to the speaker for nominal 4 Ω operation. The system connections shall be protected from the elements by a screw affixed weather resistant cover.