



PROFESSIONAL QUALITY COOKING EQUIPMENT

USE AND CARE MANUAL FOR
LEGEND RANGETOP

MODEL NUMBERS:

ARSCT-244, ARSCT-304, ARSCT-366, ARSCT-364GD, ARSCT-364GR, ARSCT-486GD,
ARSCT-486GR, ARSCT-4842GD, ARSCT-4842GR, ARSCT-6062GD, ASRSCT-6062GR,
ARSCT-606GDGR, ARSCT-244S, ARSCT-304S, ARSCT-366S



DESIGN



CLASS



FUNCTION

RETAIN THIS MANUAL FOR FUTURE REFERENCE



FOR  
YOUR  
SAFETY

**FOR YOUR SAFETY!**

Do not store or use gasoline or other flammable vapors or liquids in the vicinity of this or any other appliance.

FOR  
YOUR  
SAFETY

WARNING

IMPROPER  
INSTALLATION

**WARNING!**

Improper installation, adjustment, alteration, service or maintenance can cause property damage, injury or death and will void warranty. Read the installation, operating and maintenance instructions thoroughly before installing or servicing this equipment.

WARNING

IMPROPER  
INSTALLATION

**IMPORTANT SERVICE NOTICE!**

Using any part other than genuine American Range factory supplied parts relieves the manufacturer of all liability. American Range reserves the right to change specifications and product design without notice. Such revisions do not entitle the buyer to corresponding changes, improvements, additions or replacements for the previously purchased equipment.

Instruction to be followed in the event the user smells gas should be posted in a prominent location. This information should be obtained by consulting the local gas supplier.

**RETAIN THIS MANUAL FOR FUTURE REFERENCE.**

This equipment is design engineered for commercial use only.

Model Number: \_\_\_\_\_

Serial Number: \_\_\_\_\_

Purchase Date: \_\_\_\_\_

Installed By: \_\_\_\_\_ Install Date: \_\_\_\_\_

Gas Type: \_\_\_\_\_

Electrical Information: \_\_\_\_\_



## PROFESSIONAL QUALITY COOKING EQUIPMENT

To Our Most Valued Customer:

Congratulations on your purchase of an American Range product. We hope you will enjoy the design, manufactured quality, innovative features and cooking performance of this product – it represents our continuing dedication to satisfying the most demanding needs of customers like you.

Please read this manual and become familiar with important safety information about how to install and set-up the unit, basic operating instructions, and how to maintain that just-like-brand-new appearance and performance - over years of day-to-day and special holiday use.

If you should encounter any sort of problem, turn to the section of the manual entitled, "Troubleshooting" – for a quick solution or guidance regarding the next step required to get back to tip-top condition.

Thank you for choosing an American Range product for your home. As you can expect, this appliance is designed for years of reliable service. If you have any questions or comments, please contact the dealer from whom you purchased the unit, or contact American Range Customer Service at [www.americanrange.com](http://www.americanrange.com) or 818.897.0808.

Sincerely,

*Shane Demirjian*

President, American Range Corporation

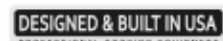

## Table of Contents

<b>GENERAL</b> .....	<b>1-5</b>
General Information.....	1
About This Manual.....	2
Shipping Damage Information.....	3
Precautions.....	3-5
<b>INSTALLATION</b> .....	<b>6-16</b>
Cabinet Preparation.....	6
Electrical Connection.....	6
Gas Connection.....	6
Pressure Regulator.....	7
Gas Requirements.....	7
Flexible Couplings, Connectors, Casters.....	7
Installation Diagrams.....	9-14
Installation Checklist.....	15
Model & Parts Identification Table.....	16
Typical Model and Parts Identification.....	17
<b>BEFORE USING RANGETOP</b> .....	<b>18</b>
<b>BURNER OPERATION</b> .....	<b>18</b>
<b>AUTO RE-IGNITION</b> .....	<b>18</b>
<b>COOKWARE</b> .....	<b>19</b>
<b>SUGGESTED BURNER SETTINGS</b> .....	<b>19</b>
<b>GRILL</b> .....	<b>20</b>
Operation.....	20
Using Grill.....	20
Best Cooking Results.....	20
Grill Chart.....	20
<b>GRIDDLE</b> .....	<b>21</b>
Seasoning.....	21
Cleaning.....	21
To Start Cooking.....	21
<b>CLEANING THE RANGETOP</b> .....	<b>22</b>
<b>TROUBLESHOOTING</b> .....	<b>23</b>

## WARNING

If the information in this manual is not followed exactly, a fire or explosion may result causing damage, personal injury or death.

- INSTALLATION AND SERVICE MUST BE PERFORMED BY A CERTIFIED / LICENSED INSTALLER, SERVICE AGENCY OR THE GAS SUPPLIER
- Do not store or use gasoline or other flammable vapors or liquids in the vicinity of this or any other appliance.

- WHAT TO DO IF YOU SMELL GAS
  - Do not try to light any appliance.
  - Do not touch any electrical switch, do not use any phone in your building.
  - Immediately call your gas company. Follow the gas supplier instructions.
  - If you cannot reach your gas supplier, call the Fire Department.

### WARRANTY REQUIREMENT

For reliable operation and for your own safety, this professional cooking equipment must be installed by a certified/licensed contractor.

Failure to comply will void any written or implied warranty.

Should the equipment require service during the standard warranty period, the receipt proving certified installation must be made available to American Range for verification.

If installation was not performed by a certified/licensed contractor be prepared to submit a major credit card for payment for proper installation.

- Please observe all local and national codes and ordinances.
- Do not remove any permanent warning labels or plates from this product.
- Please ensure that this product is electrically grounded.
- Consumers should retain these instructions for local inspectors and for future use.

## ABOUT THIS MANUAL

The Use and Care Manual is divided into several sections:

**The Safety Section** informs you about significant safety precautions when installing and operating your new fryer. This is a must read section of the manual.

**Quick Start and Installation Section** describes how to unpack the unit, what to save and what to discard, installation dimensions, gas and electrical connections and how to identify the primary parts of the product so you can better understand what's going on "under the hood".

**How to Use Your Product** shows you how to light the pilot and set frying temperatures.

**The Care and Maintenance and Troubleshooting and Service Sections** discuss how to keep your product in good operating condition, how to identify what might be going wrong with the unit, and how to communicate your observations with authorized field service technicians.

**Before using your appliance, please read this manual paying special attention to the important safety instructions located in the next several pages.**



This is the SAFETY ALERT SYMBOL. This symbol alerts you to hazards which will result in severe injury or death.



### DANGER

Hazards or unsafe practices which will result in severe personal injury or death.



### WARNING

Hazards or unsafe practices which may result in severe personal injury or death.



### CAUTION

Hazards or unsafe practices which may result in minor personal injury or property damage.

### CALIFORNIA PROPOSITION 65 WARNING

The burning of gas cooking fuel generates some by-products which are on the list of substances known by the State of California to cause cancer or reproductive harm. California law requires businesses to warn customers of potential exposure to such substances. To minimize exposure to these substances, always operate this unit according to the Owners Manual, ensuring you provide proper ventilation when cooking with gas.

## PRECAUTIONS

### SHIPPING DAMAGE CLAIM PROCEDURE

The equipment is crafted and inspected carefully by skilled personnel before leaving the factory. The transportation company assumes full responsibility for the safe delivery upon acceptance of the equipment.

If you receive a damaged product, immediately contact your delivery company, your dealer, your builder or installer. Do not install or attempt to operate a damaged appliance.

1. Note on the freight bill or express delivery any visible loss or damage and have the note signed by the person making the delivery.
2. File claim for damages immediately regardless of the extent of damages.
3. For damage noticed after unpacking (concealed loss or damage), notify the transportation company immediately and file a "Concealed Damage" claim with them. This should be done within fifteen (15) days from the date that delivery is made to you. Retain the shipping container for inspection.

### CAUTION

Check your local building codes for proper installation methods. In the absence of local codes, this appliance should be installed in accordance with the National Fuel Gas Code No. Z223.1 current issue, and the National Electrical Code ANSI/NFPA No. 70 current issue, or the CAN – B149 Installation Codes for Gas Burning Appliances, and C22.1 Canadian Electrical Code Part I. Verify the type of gas supplied to the location, being sure that the appliance is connected to the type of gas for which it is certified. Models come from the factory certified for use with Natural Gas (NG) or Liquid Propane (LP) gas. Your product, shown on the rating label and the supplied gas type must be the same. Upon opening your product, the rating label can be located on the front panel if it is a range or oven. If it is a rangetop it can be found on the side panel underneath the left burner.

If connecting this appliance to propane gas, make certain the propane gas tank is equipped with its own high-pressure regulator - in addition to the pressure regulator supplied with this product when applicable. The maximum propane gas pressure to this appliance must not exceed 14.0 inches of water column (34.9 millibar) from the propane gas tank to the pressure regulator.

Your appliance must be installed by a qualified gas installation technician. Have the technician show you the exact location of the gas shut-off valve on the incoming gas line so you know how to turn off the gas if necessary.

### CAUTION

For personal safety, this appliance must be connected to a properly grounded and polarized electrical power supply. If only a two-prong outlet is available, it is the customer's responsibility to have it replaced with a dedicated, grounded, three-prong electrical outlet by a licensed technician. The gas surface burner re-ignition system when applicable depends on a low resistance electrical ground connection for reliable operation.

- Do not cut or remove the third (ground) prong from the power cord
- Do not use an adapter plug
- Do not use an extension cord
- Do not use a power cord that is frayed or damaged
- Do not plug the appliance into an electrical outlet with a Ground Fault Circuit Interrupter (GFCI)

**⚠ DANGER**

To avoid the possibility of explosion or fire, do not store or use combustible, flammable or explosive liquids (such as gasoline) or vapors inside or in the vicinity of this or any other appliance. Keep items that could explode, such as aerosol cans, away from the product. Do not store explosive or flammable materials in nearby cabinets or areas. When operating the oven or broiler, do not touch the surfaces of the ceramic tile broiler, the rack or rack supports, the walls of the oven or the inside surfaces of the oven door - interior surfaces become hot enough to cause burns. The heat deflector, which deflects heat away from the control panel, and the oven door sides will also be hot during use.

**⚠ DANGER**

Do not store items of interest to children above or near the appliance. Children, as well as adults, should never be allowed to sit, stand or climb on any part of the appliance. Serious personal injury may occur.

**⚠ WARNING**

Always disconnect the electrical plug from the wall outlet before servicing the unit. It is recommended that a dedicated electrical circuit be used for this appliance.  
Always turn gas shut-off valve to OFF position before servicing unit.

**⚠ WARNING****POWER FAILURE WARNING**

Due to safety considerations and the possibility of personal injury, do not attempt to light or operate rangetop burners, grills, griddles, the oven or broiler during a power failure. Safety systems which detect the presence of an ignition source and operate the gas safety valve do not function during a power failure. Be sure all gas valve knobs are turned to and remain in the OFF position during a power failure.

**IMPORTANT SAFETY NOTICE AND WARNING**

The California Safe Drinking Water and Toxic Enforcement Act of 1986 (Proposition 65) requires the Governor of California to publish a list of substances known to the State of California to cause cancer or reproductive harm, and requires businesses to warn customers of potential exposures to such substances. Users of this appliance are hereby warned that when the oven is operated, there may be some low-level exposure to some of the listed substances including carbon monoxide. Exposure to these substances can be minimized by properly venting the oven to the outdoors using approved overhead ventilation equipment or by opening the windows and/or doors in the room where the appliance is located.

This is a vented appliance. The appliance should not be installed with a ventilation system that blows air downward towards the rangetop. This type of ventilation system may cause ignition and combustion problems with the gas cooking appliance resulting in personal injury or unintended operation.

Air curtain or other overhead rangetop hood, which operates by blowing a downward airflow onto a rangetop, shall not be used in conjunction with this appliance.

This appliance should not be operated without a properly sized and functional ventilation hood.

**⚠ WARNING**

To reduce the risk of appliance tipping, it must be secured to the wall with a properly installed anti-tip bracket. To make sure the bracket has been installed properly, inspect behind the rangetop using a flashlight.

- Anti-tip devices are only necessary for rangetop products.
- This rangetop can tip causing personal injury
- See Installation Instructions supplied with the rangetop and install the anti-tip device packaged with the rangetop
- If the anti-tip device cannot be located, contact American Range Customer Service by calling 818.897.0808 or by contacting us at [www.americanrange.com](http://www.americanrange.com)



 CAUTION

Purchase a kitchen fire extinguisher for your home and store it in close proximity to your appliance. Should an uncontrolled fire occur, never use water on grease fires. Never pick up a flaming pan. The oven door interior and exterior, especially the oven door glass can get hot during operation. Do not touch the glass – use the door handle to open or close the range door.

The push-to-turn gas valve knobs on the appliance are designed to be child-safe, however, they are not a guarantee of operation. Children should not be left alone or unattended in the kitchen while the appliance is in use. Never leave the appliance unattended during use. Boil-overs may occur, causing spills which may ignite.

Never wear loose fitting or long sleeved apparel while cooking. Never wear garments made of flammable materials. Clothing may ignite or catch utensil handles. **DO NOT** drape towels or other items on door handles. These items could ignite and cause burns.

If your product is a range or oven **ALWAYS** place oven racks in the desired position before you start cooking and while the oven is cool. Always use dry and sturdy pot-holders to carefully slide the oven rack out to add or remove food.

If your product is a range or rangetop located near a window, be certain window curtains or other flammable objects do not blow over or near the range burners; the items could catch on fire.

If operating the surface burners, the flame should be adjusted to just cover the bottom of the pan or pot. Excessive high flame settings may cause scorching of the nearby counter-top surface, as well as the outside of the utensil and handles.

**ALWAYS** turn the appliance off at the end of cooking.

When dehydrating food items, periodically check during the process to ensure that they do not catch on fire.

If you are "flaming" liquor or other spirits under an exhaust, **TURN THE FAN OFF**. The draft from the fan could cause the flames to spread out of control.

Care should be exercised if your appliance is equipped with a high-shelf. During heavy or continuous use, this shelf may be come hot. Do not place combustible materials or plastic items on the shelf.

Turn the knobs to the **OFF** position prior to removing them from the valve stems for cleaning.

 WARNING

**NEVER** use this appliance as a space heater to heat or warm the room. Doing so may result in carbon monoxide poisoning and overheating of the appliance. Do not use the rangetop or oven as a food or kitchen item storage area.

Never block or cover any slots, holes or passages located anywhere inside or outside the rangetop. These structures are important to safe operation of the appliance and doing so may block airflow through the oven or rangetop possibly causing carbon monoxide poisoning or fire. Routinely keep all slots free of grease and other materials.

This appliance has been tested for safe performance using conventional cookware. **DO NOT USE** any device or accessory not specifically recommended in this guide. **DO NOT USE** pan or pan covers on surface units, grills or griddles. These devices can create serious safety hazards including personal injury, create performance problems and may damage the appliance.

Do not store or use corrosive chemicals, vapors, flammables or non-food products in or near this appliance. It is specifically designed for use when heating or cooking food. The use of corrosive chemicals while heating or cleaning could result in personal injury or damage to the appliance.

## INSTALLATION INSTRUCTIONS

The location selected for the rangetop must meet the following criteria. If any of these criteria are not met, select another location.

### CABINET PREPARATION

- This rangetop is a free standing unit.
- The rangetop can be placed in various positions with respect to the cabinet front, with the front either flush or projecting, depending on the countertop width.
- The rangetop is zero-clearance safe against non-combustible surfaces.
- The maximum depth of overhead cabinets installed on either side of the hood is 13".
- Any openings in the wall behind the rangetop and in the floor under the rangetop must be sealed.
- When there is less than 12" clearance between combustible material and the back edge of the rangetop above the cooking surface, a backguard must be installed.
- When clearance to combustible material is over 12" no backguard is necessary.
- Back guards must be ordered separately. To order, measure the space that the back guard must have and order accordingly.

### ELECTRICAL CONNECTION

- The rangetop must be electrically grounded in compliance with local codes or, in the absence of local codes, with the National Electrical Code, ANSI/NFPA70.
- This rangetop requires a 120 volt supply to operate the ignition system. The supply cord provided on the rangetop is equipped with a three-prong (grounding) plug for protection against electrical shock.
- The electrical service in the building must be equipped with a properly grounded three-prong receptacle.
- Do not cut or remove grounding prong from this plug.**

### POWER REQUIREMENTS FOR THIS RANGETOP

- 120 VAC, 60 Hz, single phase, 15 AMP Max

### GAS CONNECTION

Be certain the appliance being installed is correct for the gas service being provided. Refer to the appliance data plate for the gas supply requirements.

A manual gas shut-off valve must be remotely installed and easily accessible in the adjacent cabinet. The regulator inlet is for a 3/4 inch gas line. The appliance ships with a 1/2 inch to 3/4 inch adapter connected to the regulator.

- Use at least a 1/2" commercial flex hose to connect rangetop to the gas supply (service line).
- A manual gas shut-off valve must be installed, in easy access in front of the gas supply (service line) and ahead of the rangetop for safety and ease of maintenance.
- All valves must be in the OFF position before connecting to the gas supply line.

## INSTALLATION INSTRUCTIONS

### PRESSURE REGULATOR

- ☑ The regulator installed in the rangetop is adjusted at the factory for 5" WC (natural gas) or 10" WC (L.P.) depending on the customer's request. Regulators must not be removed.
- ☑ The regulator can withstand a maximum pressure of 1/2 PSIG (14" WC). If the line pressure is beyond this limit, a step-down regulator will be required.
- ☑ Any adjustment to regulators must be made **ONLY BY QUALIFIED** service personnel with proper test equipment.

### GAS REQUIREMENTS

- ☑ Ensure supplied gas matches the rangetop's gas type.
- ☑ Natural gas connection is 1/2" N.P.T. minimum 1/2" diameter flex line.
- ☑ Natural gas inlet pressure to measure 7" to 10" W.C.
- ☑ Propane gas connection is 1/2" N.P.T. minimum 1/2" diameter flex line.
- ☑ LP gas inlet pressure to measure 11" to 14" W.C.
- ☑ A step-down regulator in addition to the regulator provided with the LP rangetop is required at the LP (Propane) source to limit pressure to a maximum of 14" W.C.

Check that all gas connections are properly sealed with a suitable gas joint compound.

### TEST ALL JOINTS WITH A SOAPY WATER SOLUTION BEFORE LIGHTING THE BURNERS.

1. Turn ON the manual gas valve at the inlet side of the gas supply line.
2. Check for gas leaks at the flexible coupling or gas connector fitting using a solution of one part soap and three parts water.
3. Sparingly spray or brush the soapy solution at the gas fittings; active bubbling indicates location of gas leak.
4. If a gas leak is detected turn off the manual gas valve at the inlet side of the gas line. Call your certified service technician.

### FLEXIBLE COUPLINGS, CONNECTORS AND CASTERS

- ☑ Flexible couplings and/or quick-disconnect fittings must be heavy duty, CSA/UL design certified of at least 1/2" NPT with suitable strain reliefs.
- ☑ The flexible connector must comply with the standard for Connectors for Movable Gas Appliances, ANSI Z21.69-CSA 6.16 and any Quick-Disconnect Devices For Use With Gas Fuel Appliances should comply with ANSI Z21.41 CSA 6.9.
- ☑ All connections must be sealed with joint compound specified for LP or Natural gas; and all connections must be tested with a soapy water solution before using.
- ☑ When disconnection of the restraint is necessary, make sure to reconnect the restraint after the rangetop has been returned to its original position.

# INSTALLATION INSTRUCTIONS

- Do not remove protective packaging until you are ready to perform the installation.
- Do not remove the protective wrapping from the product control panel until the product is installed.
- Caution - the appliance is heavy. Use extreme care when handling!
- Use proper equipment to move products.
- Any openings in the wall and in the floor behind or under the oven must be sealed.
- Do not use an extension cord with this appliance. Such use may result in fire, electrical shock or other personal injury.
- Installation of this appliance should be performed by qualified, licensed contractors.
- To remove the packaging, first remove the staples located at the bottom perimeter of the corrugated cardboard cover.
- Remove the corrugated cardboard carton by lifting it off the product and remove the inner packing.
- Detach the product from the metal anchor strip by removing the attachment screw.
- Confirm access to adequate power and gas. See specifications & electrical requirements table.
- Fill out the inside cover of this installation manual with the requested data. Model Number and Serial Number can be found on the plate located underneath the control panel on the front of the appliance.

## ⚠ WARNING

For optimal performance, the rangetop should be installed away from drafts that may be caused by doors, windows, and heating and air conditioning outlets.

**RATING PLATE** - The information on the rating plate defines the model, serial number, gas type (natural or liquid propane), operating pressures and burner BTU ratings. Keep this information for future reference. It is essential for proper identification of the unit when requesting additional information or factory support.

		<b>AMERICAN RANGE</b> <small>American Range (www.americanrange.com)                  13592 DESMOND ST., PACOIMA, CA 91331</small>	
MODEL NO. <b>ARSC-T-304</b>	GAS TYPE <b>XXX</b>	MAN. PRESS. <b>XX</b> IN W.C. <b>XX</b>	
SERIAL NO. <b>XXXXXX-XXX</b>	BTU INPUT/HR/SECTION		
COOK TOP Large <b>17,000</b> Medium <b>13,500</b> Small <b>9,000</b>	GRILL <input type="checkbox"/>		
VOLTS <b>120</b> AMPS <b>9</b> OVEN BK 18 <input type="checkbox"/>	BROIL 18 <input type="checkbox"/>		
CYCLES <b>60</b> PHASE <b>1</b> BK 24,30,36 <b>28,000</b>	BR 24,30,36 <input type="checkbox"/>		
ANSI Z21. 1b - 2003 HOUSEHOLD COOKING APPLIANCES		GRIDDLE <input type="checkbox"/>	

Rating Plate

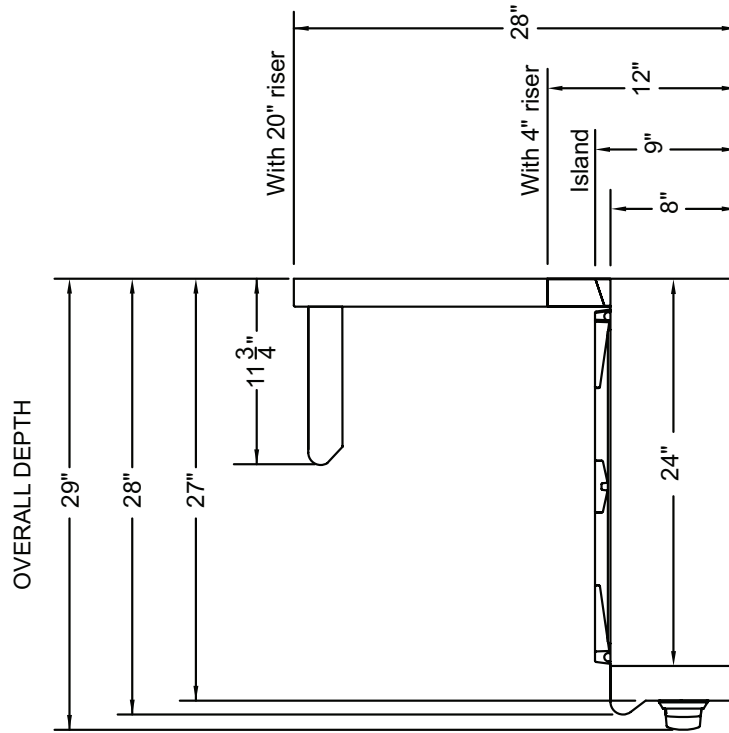

Overall Dimensions  
RANGETOP

SIZE	"A"	"B"
24"	24"	23.875"
30"	30"	29.875"
36"	36"	35.875"
48"	48"	47.875"
60"	60"	59.875"

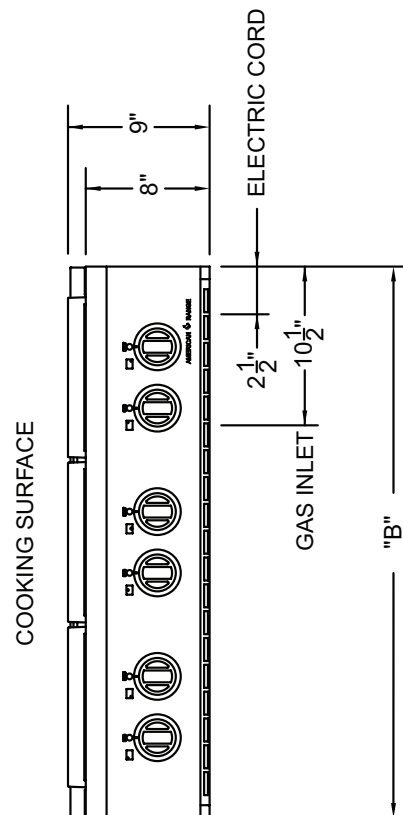

Installations Specifications  
RANGETOP

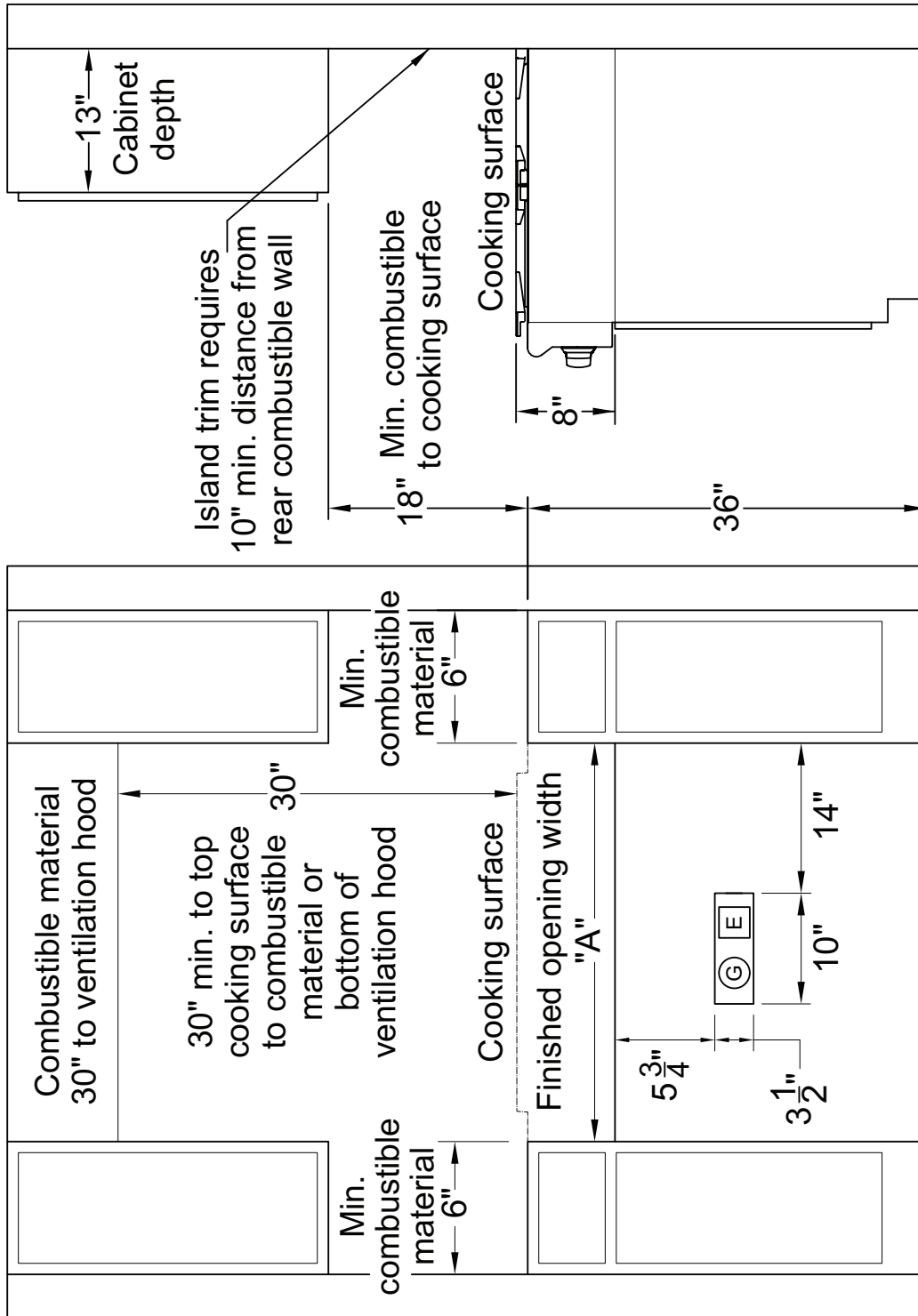

ⓐ ⓔ Location of gas and electrical supply



Installations Specifications  
Step Up Rangetop

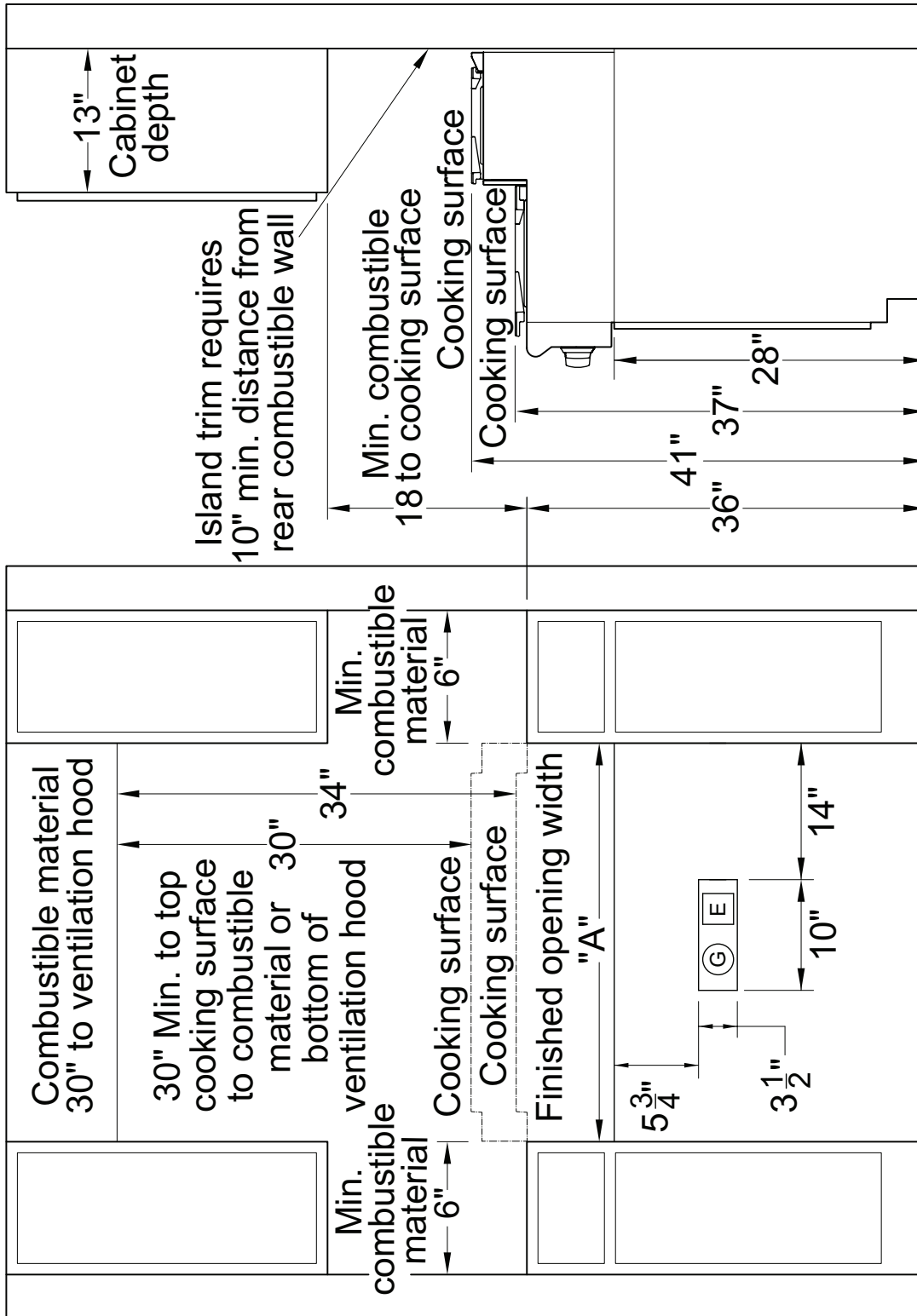



OVERALL DIMENSIONS LEGEND RANGETOP

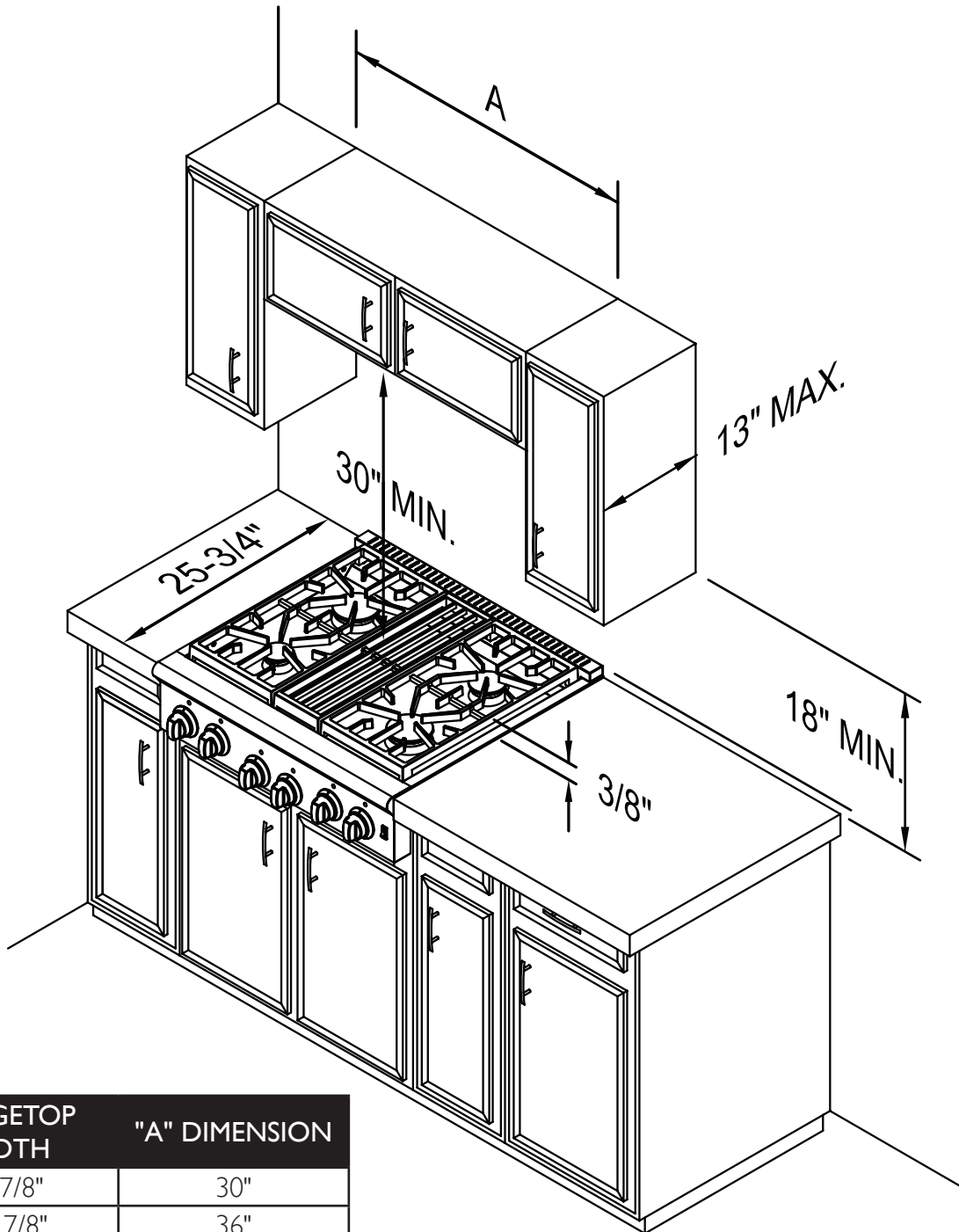

RANGETOP WIDTH	"A" DIMENSION
23-7/8"	30"
29-7/8"	36"
35-7/8"	48"
47-7/8"	60"
59-7/8"	66"

## VENT HOOD CLEARANCE DIMENSIONS

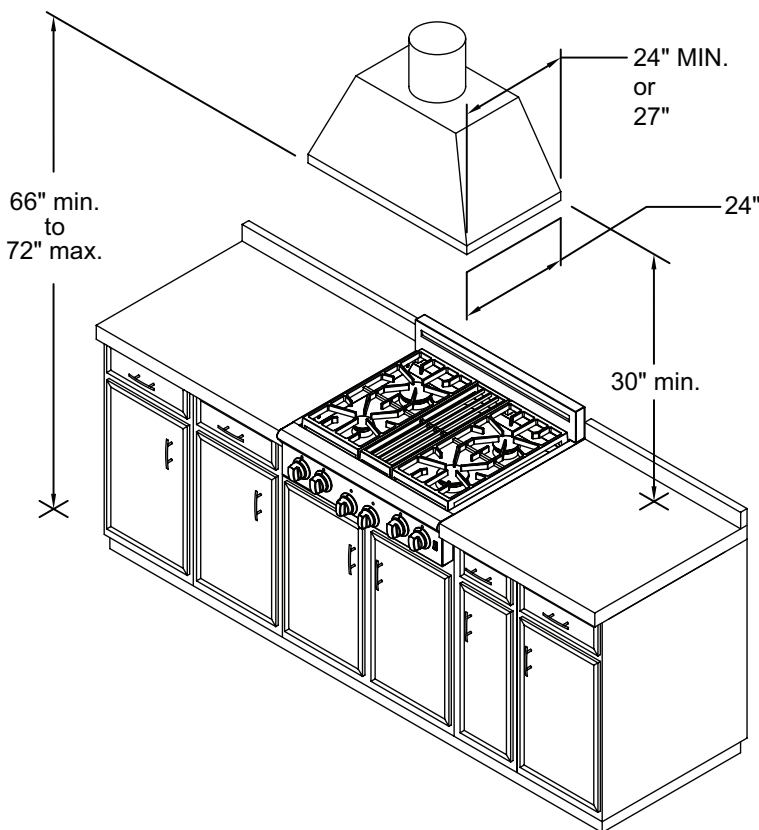

### **⚠ WARNING**

This is a vented appliance. The appliance should not be installed with a ventilation system that blows air downward towards the rangetop. This type of ventilation system may cause ignition and combustion problems with the gas cooking appliance resulting in personal injury or unintended operation.

Air curtain or other overhead rangetop hood, which operates by blowing a downward airflow onto a rangetop, shall not be used in conjunction with this appliance.

### VENT HOOD REQUIREMENTS & RECOMMENDATIONS

VENTILATION UNIT	STANDARD COUNTER	ISLAND INSTALLATION
Hood Size	24" Deep x Unit Width	30" Deep x Unit Width
Blower Size	48" Rangetop 600-1200 CFM	600-1200 CFM
	36" Rangetop 600-800 CFM	600-1200 CFM
	30" Rangetop 300 CFM	300 CFM

## INSTALLATION CHECKLIST

This checklist has been developed to assure proper installation of your oven.

To validate warranty, you must mail, e-mail or fax this form and a copy of your receipt to:

AMERICAN RANGE CUSTOMER SERVICE, 13592 DESMOND STREET, PACOIMA, CA 91331

service@americanrange.com

818.897.8839 FAX

Street: \_\_\_\_\_

Purchase Date: \_\_\_\_\_

City, State, Zip Code: \_\_\_\_\_

Installation Date: \_\_\_\_\_

E-mail: \_\_\_\_\_

Installer's Name: \_\_\_\_\_

Telephone: \_\_\_\_\_

Company: \_\_\_\_\_

Dealer: \_\_\_\_\_

Telephone: \_\_\_\_\_

### CHECK ALL THAT APPLY

#### Appearance and Aesthetics

- Exterior
- Top section
- Oven interior

#### Installation

- Read User Manual
- Review Safety Instructions
- Proximity to cabinets
- Backguard in place
- Level
- Ventilation system

#### Ignition

- Top Burners
- Griddle
- Char Broiler
- Oven Burner
- Infrared Broiler

#### Controls

- Burner Knobs
- Thermostats
- Char Broiler
- Convection Oven Fan & Switch
- Oven Light Switch

#### Electrical Connection

- Correct voltage
- Grounded outlet
- Polarized outlet
- No GFCI

#### Gas Connection

- Verify fuel:  Natural -or-  LP
- Gas shut-off present and accessible
- Gas Supply line properly sized
- Gas Supply pressure checked
- Operating pressure checked
- All connections checked for leaks

#### Flame Adjustment

- Top Burners
- Griddle
- Char Broiler
- Oven Burner
- Infrared Broiler

#### Air/Gas Mixture

- Top Burners
- Griddle
- Char Broiler
- Oven Burner
- Infrared Broiler

#### Valve Operation

- Top Burners
- Griddle
- Char Broiler
- Oven Burner
- Infrared Broiler

Customer Copy

## MODEL AND PARTS IDENTIFICATION

DESCRIPTION	LEGEND SERIES - RANGETOP														
	ARST-244	ARST-304	ARST-366	ARST-364GD	ARST-364GR	ARST-486GD	ARST-486GR	ARST-4842GD	ARST-4842GR	ARST-6062GD	ARST-6062GR	ARST-606GDGR	ARST-244S	ARST-304S	ARST-366S
Total Control Knobs	4	4	6	5	5	7	7	6	6	8	8	8	4	4	6
Sealed Burners	4	4	6	4	4	6	6	4	4	6	6	6	4	4	6
Griddle				1		1	0	2		2	0	1	0	0	0
Backyard Grill					1		1		2		2				
Burner Grates	2	3	3	2	2	3	3	2	2	3	3	3	2	2	3
Center Plate	0	1	0	0	0	0	0	0	0	0	0	0	0	1	0
Island back	1	1	1	1	1	1	1	1	1	1	1	1	1	1	1
4" Stub back	0	0	0	0	0	0	0	0	0	0	0	0	0	0	0
Regs. Card	1	1	1	1	1	1	1	1	1	1	1	1	1	1	1
U&C Manual	1	1	1	1	1	1	1	1	1	1	1	1	1	1	1

# TYPICAL MODEL & PARTS IDENTIFICATION

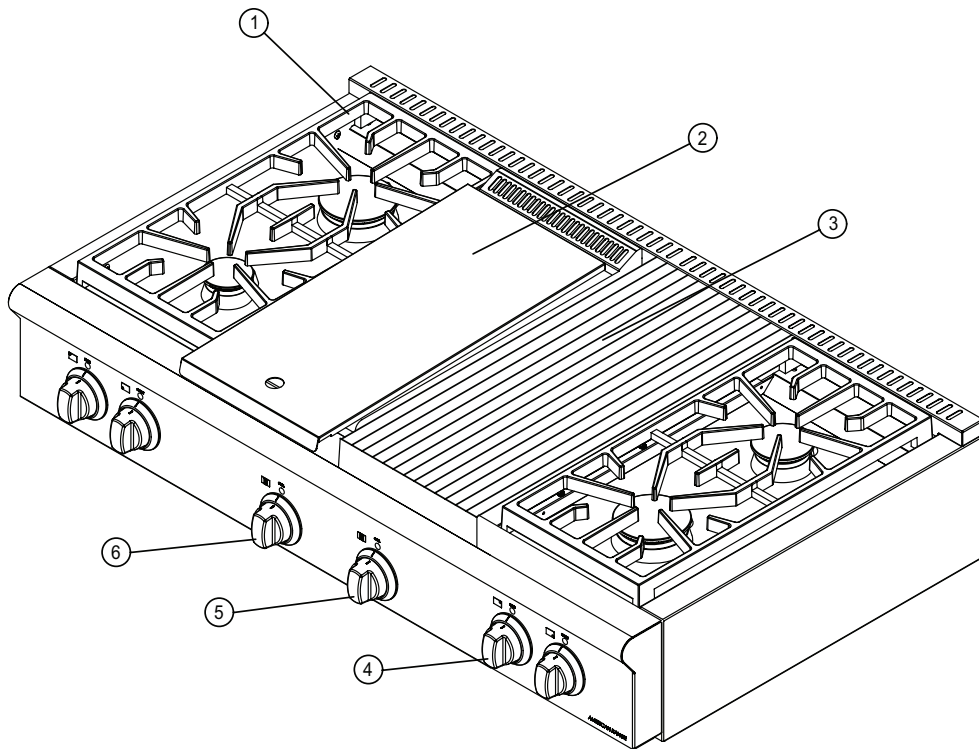
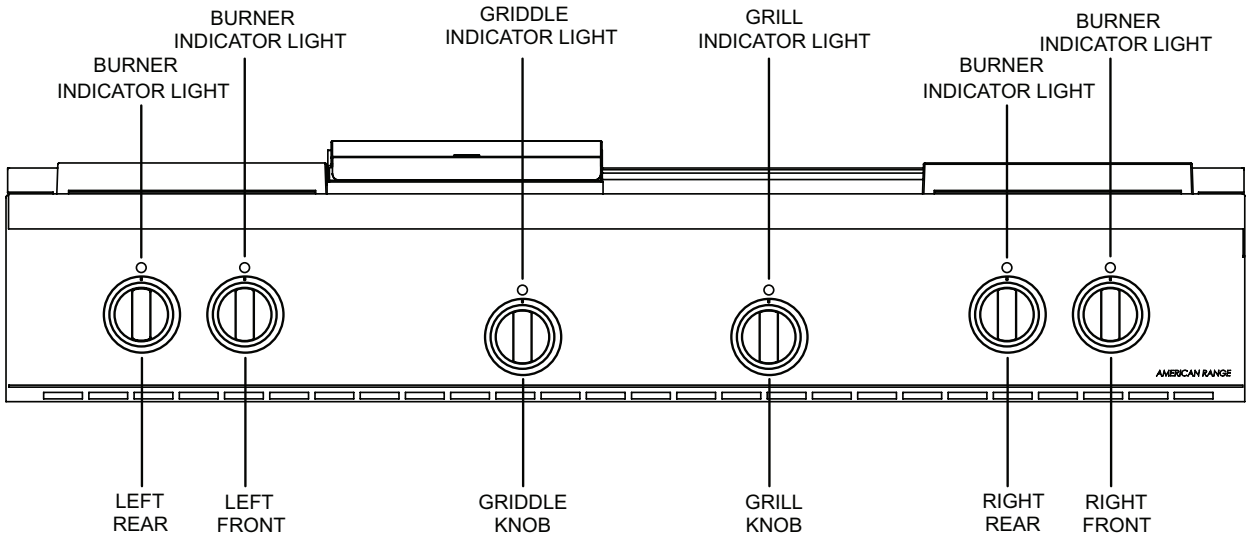

- 1. Grate
- 2. Griddle
- 3. Grill
- 4. Burner Knob
- 5. Grill Knob
- 6. Griddle Knob

## BEFORE USING THE NEW RANGETOP

- Before using the rangetop for the first time, wash the outside area with soap and water to remove any shipping & factory residue.
- The burner grates are designed in sections and are easy to remove and clean. They are made of cast iron with a porcelain coating and will remain hot after the burner is turned-off creating a residual heat for continued cooking. Use caution when handling.
- Your new professional rangetop is equipped with burners that are similar to those used in restaurants.
- The burner heads are large and designed to ensure even heat distribution for better cooking. They must be in place and properly seated before lighting.
- The rangetop must not be operated without the burner heads.
- There are no continuously burning pilot lights. An electronic spark ignition system is used to light the burner. If the flame should go out from a boil-over or a strong draft, the burner will automatically re-ignite.

## OPERATION OF THE BURNERS

1. Use the front panel graphic to confirm your selection until you become familiar with the rangetop. Press in on the knob that corresponds to the burner that you would like to light. Turn the knob counter-clockwise to the "American Flame" icon located on the knob – this is the light position of the burner valve.
2. The igniter for all the surface burners will begin sparking – however, gas will flow to only the selected burner.
3. After the burner lights, the igniter clicking will stop – indicating that the flame sensing and re-ignition system is active on the selected burner.
4. Rotate the knob to any flame setting that you desire between MAX and SIMMER. The blue panel light will remain lit until the valve is returned to the OFF position.

The surface burners are rated at different power levels:

BURNER TYPE	SMALL	MEDIUM	LARGE
Sealed Burners	9,000 BTU/hr.	13,000 BTU/hr.	17,000 BTU/hr.

When you are using the surface burners, select the burner power and location depending on the heating or cooking function you would like to perform.

A normal flame is blue in color and steady. Foreign materials in the kitchen air or the gas line, especially in new construction installations, may cause some orange color bursts during initial operation. This will disappear with continued use. Small yellow tips on the ends of flames are normal when using LP gas.

If the flames look odd, (too small, too large, lazy or drifting, uneven around the burner circle, etc.), check to see that the burner head is seated correctly on the burner base. Do this when the burner is cold by gently rocking the burner head or rotating the head from side to side. If it is correctly seated, it will nest in detents, in the case of the sealed burners, or on the corresponding pin/hole for open burners. If this does not correct the problem, turn to the Troubleshooting section of this manual.

## AUTO RE-IGNITION

The surface burners are equipped with a special ignition and re-ignition system that senses the presence of flame and re-ignites the burner should the flame disappear while gas is still flowing to the burner.

Strong drafts, spills and general grime influence the operation of the automatic re-ignition system – a clean system will generally function better than a dirty system. Periodically remove any materials or grime that might build up on the high voltage spark electrode – using a toothbrush or other non-metallic cleaning utensil.

## COOKWARE RECOMMENDATIONS

To avoid the risk of serious injury, damage to the rangetop or cookware, please observe the following guidelines.

Bakeware, such as large casserole pans, cookie sheets, etc., should never be used on the rangetop.

Placement of large stock pots should be staggered when used on the rangetop. Select the base diameter of the pot to match the diameter of the flame. The diameter of the flame and the diameter of the pan bottom should match or be slightly smaller. Too large or too small pots on a burner will compromise cooking performance.

Do not place food packaged or wrapped in aluminum foil directly on the burner grate above the burner. Aluminum foil can melt during cooking.

Be careful to not let plastic, paper or cloth come in contact with a hot burner grate. These materials can catch fire or melt.

Never let a pan boil dry – and if it occurs remember it can be extremely hot – and very dangerous. If this should occur, turn off the burner immediately. Wait a while, until the pot cools down enough to handle – this could be several minutes, but could save you from burns or other serious injury.

The pan bottom should be flat, the heavier the better – and well balanced on the rangetop grate – sitting flat without rocking – preferably with tight fitting lids. Try not to slide the pot across the grates – while it is very handy to do so – you may end up scratching the pot or the grate.

Always be careful when using high flames, as in wok cooking, as they may ignite nearby flammable materials or make the handles of the wok very hot. Use the wok ring (optional) to stabilize the wok.

SUGGESTED BURNER SETTINGS	
HEAT SETTINGS	USE
Simmer	Melting small quantities of butter, simmer grains, rice, oatmeal
Low	Poaching eggs, fish, poultry
Low - Medium	Fry eggs, heat milk, cream sauces
Medium	Puddings, custards, gravies
Medium High	Sauté vegetables, braise meats, soups and stews, deep fat frying, boiling water and pasta, blanching vegetables, searing meats
High	Large quantity of water to boil, large quantity frying and cooking

## GRILL OPERATION

To turn on the grill, make sure there is nothing on the grilling rack, push in and turn the control counter clockwise to the HIGH position. The power ON indicator light will glow indicating the grill valve is on. The grill is equipped with a flame-sensing ignition system – that automatically detects the presence of flame on the grill burner – and relights it in the event it should go out. Adjust the flame to the desired height.

After cooking, allow the module to cool completely and remove the drip tray slowly, discarding grease and other food particles. The grill grate may be removed - exposing the radiants - which may be lifted out and placed in the dishwasher along with the drip tray for cleaning. The grate is porcelain coated and may be washed with hot soapy water and a soft brush.

## USING YOUR GRILL

- Before starting to cook, check that Stainless Steel radiant, grease collector and grill grates are in place.
- This gas grill may cook slightly faster, so adjust preheat and grilling times to allow for less cooking time than expected.
- Push in the control knob and turn to ON. Rotate the knob counter-clockwise. You will hear a puffing sound as the burner ignites and a blue light will indicate that the burner is lit.
- Turn on the exhaust fan above your rangetop.
- Preheat the grill for two to five minutes. The longer preheat time ensures darker grill marks on the food.
- Fatty foods or any excess fat used to marinate can cause minor flare-ups or puffs of flame. A small amount of flare-up is normal.

## BEST COOKING RESULTS WHEN USING YOUR GRILL

The intense radiant heat from the grill vaporizes the surface of your food, locking in flavor:

- Add any barbecue sauces during the last few minutes of cooking, long enough to caramelize the sauce.
- For best results, turn food with tongs or a flat spatula to avoid piercing meat or poultry.
- Turn meat once when juices rise to the surface. Turning meat more than once results in the loss of meat juices.
- Never squeeze juices out of meat.
- Before cooking steaks or chops, trim most of the outside fat to prevent excessive flare-ups. Slash into the edges of steaks or chops to keep meat flat on the grill.
- Fish should be cooked at the lowest setting eight to ten minutes for every inch of thickness, measured at the thickest part of the fish.

GRILL CHART		
FOOD ITEM	INTERNAL TEMPERATURE	TIME
Hamburgers 1/2" to 3/4"	160°	8 to 10 minutes
Steaks 1" to 1-1/2"	Rare 140°	10 to 20 minutes
Steaks 1" to 1-1/2"	Medium 160°	12 to 25 minutes
Pork chops 3/4" to 1"	145° & 3 minutes rest time	15 to 25 minutes
Lamb chops	160°	12 to 15 minutes
Poultry pieces	170°	25 to 35 minutes
Fish 1" thick	145° Minimum	8 to 10 minutes

Allow grill to cool completely before cleaning. Remove the grates, grease collector and Stainless Steel Radiant and place in hot soapy water. Clean the grill with hot soapy water and a soft grill brush.

**Do not apply water or cleaner directly on the infrared burner.**



## USING THE GRIDDLE

The built-in griddle is made of polished steel to provide a smooth cooking surface. A griddle drip pan is included.

### SEASON THE GRIDDLE

1. The griddle has a factory applied coating that must be washed off before using for the first time. (See Cleaning the Griddle below).
2. Pour one Tablespoon of vegetable oil or canola oil and rub on the entire surface of the griddle using a rough cloth.
3. Push the griddle control knob in and turn to a medium setting (350°)
4. Heat until griddle begins to smoke. Turn off griddle and allow to cool.
5. Repeat the process one more time.

### CLEANING THE GRIDDLE

1. The griddle is not to be removed for cleaning.
2. First, clean griddle after use by scraping with a flat spatula to remove food particles.
3. Clean the griddle thoroughly with hot soapy water and a rough towel.
4. Rinse with a mixture of one quart water and one cup of vinegar.
5. To clean further, pour one teaspoon vegetable oil in center of the griddle and rub the entire surface with a clean rough towel or scrub with a nylon scrubbing pad. Wipe with a damp paper towel.
6. Clean the griddle drip pan and trough after each use with hot soapy water and a sponge.
7. It is normal for the griddle to darken with age and use.

### TO START COOKING

1. Push the knob in and turn the knob clockwise to the MAX setting.
2. Preheat griddle for two to three minutes and turn knob to a medium to low cooking setting.
3. The blue indicator light comes on and stays on until the desired setting is reached and turns off and on with the heating cycle.
4. For best results, add a small amount of fat to cook food properly, such as butter, oil or cooking spray. Fatty meats like bacon and sausage do not need extra fat.

*The following temperature settings are to be used only as a guide. You may need to vary the settings to your taste.*

GRIDDLE COOKING CHART		
FOOD ITEM	TEMPERATURE	KNOB SETTING
Eggs	225° to 250°	LOW
Bacon, Ham, Hot Dogs	300° to 325°	MEDIUM LOW
Sausage, Grilled Cheese Sandwiches	325° to 350°	MEDIUM
Pancakes, French Toast	350° to 375°	MEDIUM
Hash Brown Potatoes, Grilled Onions	400° to 425°	MEDIUM HIGH

## TO CLEAN THE RANGETOP

The rangetop is constructed from brushed Stainless Steel with polished aluminum burner heads. The burner caps are steel coated porcelain.

1. Wash all surfaces with hot water and dish detergent such as Ivory liquid or Joy.
2. Rub stubborn spots with baking soda or liquid cleaner such as Windex All Surface Cleaner or 409.
3. Do not use abrasives on Stainless Steel. Use rough towels, sponges or soft plastic scrubbers.  
**RUB ONLY WITH THE "GRAIN".**
4. Grates and burner caps can be soaked in hot soapy water.
5. Mild scouring cleaners can be used, such as Boni Ami or Cameo.
6. Do not use steel wool pads or green rough Scrubees.

## TROUBLESHOOTING GUIDE

RANGETOP		
PROBLEM	POSSIBLE CAUSE	WHAT TO DO
Rangetop will not heat	<ul style="list-style-type: none"> <li>No electrical power to the rangetop</li> <li>Gas service is turned off</li> <li>Gas supply has been interrupted</li> <li>Look for red glow of hot surface igniter</li> </ul>	<ul style="list-style-type: none"> <li>Check circuit breakers in house</li> <li>Try to light a surface burner</li> <li>Contact the gas company</li> <li>If no glow, call for service</li> </ul>
Burner lights, but clicking won't stop	<ul style="list-style-type: none"> <li>Mis-wired high voltage connections</li> <li>No ground</li> <li>Poor electrical ground</li> <li>Reversed polarity</li> </ul>	<ul style="list-style-type: none"> <li>See that the burners are correctly matched to the high voltage connections</li> </ul>
Convection fan does not turn	<ul style="list-style-type: none"> <li>Switch the fan on</li> <li>Unit in broil mode</li> <li>Bad fan</li> </ul>	<ul style="list-style-type: none"> <li>Use the control panel switch</li> <li>Turn thermostat to bake temperatures</li> <li>Call for service</li> </ul>
Igniters keep clicking	<ul style="list-style-type: none"> <li>Reverse polarity of the electrical supply line</li> <li>Poor electrical ground</li> </ul>	<ul style="list-style-type: none"> <li>Check the polarity with hand held tester</li> <li>Be sure rangetop power cord has three prongs and plugs directly (no adapter) into the power receptacle</li> </ul>
Foods over-cook	<ul style="list-style-type: none"> <li>Incorrect temperature or cooking time</li> <li>Defective thermostat</li> </ul>	<ul style="list-style-type: none"> <li>Reduce cooking time or temperature</li> <li>Verify that the thermostat indicator light cycles on and off every five or ten minutes at temperature</li> </ul>

# WARRANTY REQUIREMENT

For reliable operation and for your own safety, this professional cooking equipment must be installed by a certified/licensed contractor.

Failure to comply will void any written or implied warranty.

Should the equipment require service during the standard warranty period, the receipt proving certified installation must be made available to American Range for verification.

If installation was not performed by a certified/licensed contractor be prepared to submit a major credit card for payment for proper installation prior to service.



13592 Desmond Street, Pacoima, CA 91331  
818.897.0808 tel 888.753.9898 toll free  
818.897.1670 fax  
[www.americanrange.com](http://www.americanrange.com)