

CO29F • 21" ADA Combo® Model • ADA Series

FEATURES & BENEFITS



BLACK SOLID



WHITE SOLID

PERFORMANCE	<ul style="list-style-type: none"> • Refrigerator volume of 2.1 cu ft holds up to 24 bottles (12 oz) or 44 cans (12 oz) • Mechanical Dial Control is conveniently located on the grille • Temperature range: 34°F - 45°F • Passive cooling system • Produces and stores up to 8 lbs of ice per day • Crescent ice cube dimensions: 1/2" W x 3/4" H x 2 1/4" L
INTERIOR/EXTERIOR	<ul style="list-style-type: none"> • No drain required • Two removable tempered glass shelves • Two fixed storage compartments in door • Door swing is field reversible
INTEGRATION	<ul style="list-style-type: none"> • Unit is designed to be built-in or can be freestanding • Accepts a 1/4" custom insert panel • Available in the following finishes: Black or White

MODEL DETAILS

Model	Voltage/Hz	Door Swing	Finish	Shipping Weight
U-CO29FB-00A	115 / 60	Field Reversible	Black Solid	101 lb
U-CO29FW-00A	115 / 60	Field Reversible	White Solid	101 lb

ACCESSORIES

Model	Description	Finish	Shipping Weight
WATERHOOKUP	Braided water supply line kit	N/A	2 lb

ADA Series • 21" ADA Combo® Model • CO29F

DIMENSIONS

Dimensions shown apply to all finishes.

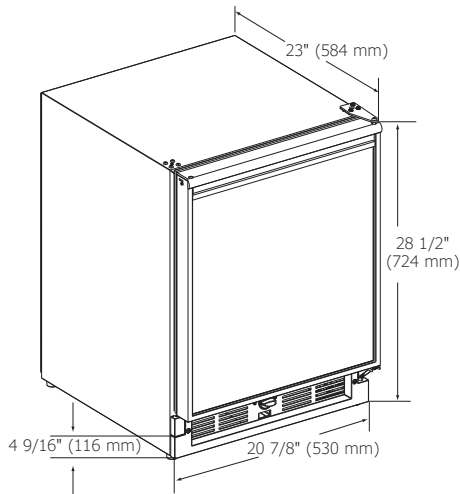

CABINET CUT-OUT

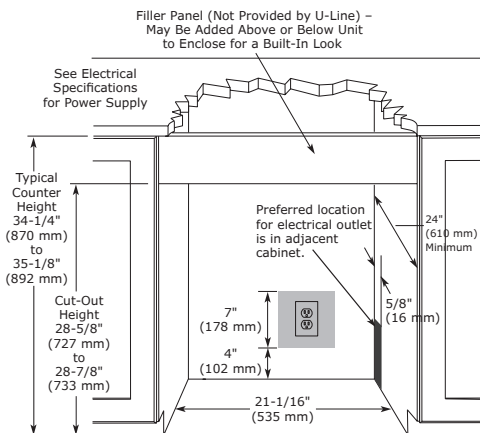

INSTALLATION NOTES

Cutout includes the additional 1/4" width overall to ensure proper installation.

When installing a left-hand hinge model, allow for 145° door swing for proper removal of ice bin.

No additional clearance around sides, top or rear of unit is needed for ventilation.

Do not obstruct front grille air flow.

SPECIFICATIONS

Model	CO29F
Amps: Running	2.5
Capacity: Bottle (12 oz)	24
Capacity: Can (12 oz)	44
Capacity: Refrigerator Volume (cu ft)	2.1
Control Type	Mechanical Dial
Defrost Type	Frost Free
Dimensions: Product Depth	23" / 584 mm
Dimensions: Product Height	28 1/2" / 724 mm
Dimensions: Product Width	20 7/8" / 530 mm
Energy Consumption: Avg. Per Year	567 kWh
ENERGY STAR	No
Ice Production Per Day	8 lb
Ice Storage	8 lb
Product Weight: Max	92 lb
Refrigerant Type	R134A
Sabbath (Star K Certified)	No
Temperature Range	34°F - 45°F

ELECTRICAL REQUIREMENTS

This unit requires a grounded, polarized 115 VAC, 60 Hz, 15 A power supply (normal household current).



Residential

Please visit U-Line.com to view this model's User Guide. All specifications are subject to change without notice.