

2200 SERIES

DUAL ZONE WINE CAPTAIN® MODELS



U-2275ZWCS-00

U-2275ZWCS-01

U-2275ZWCOL-00

U-2275ZWCOL-60

Introduction



Congratulations on your purchase of a U-Line refrigerator.

For nearly five decades and three generations, U-Line continues to be the leader in innovation, quality and value in the premium built-in undercounter ice making, refrigeration and wine preservation market. U-Line has captivated those with an appreciation for the finer things with exceptional functionality, style, inspired innovation and attention to even the smallest details. We are known and respected for our unwavering dedication to product design, quality and selection.

In 1962, Henry Uihlein founded U-Line Corporation as an outgrowth of Ben-Hur Freezer Company and was the first to develop and patent an automatic stand-alone undercounter residential ice maker. His foresight and determination to develop new ideas and to succeed when there were no clear guidelines or solutions are evident today. The newest Uihlein generation continues to build upon the family's innovative legacy at the Milwaukee, Wisconsin based business by providing continuity and vision from which new designs and technology continue to be born.

Today the complete U-Line product collection includes Ice Makers, Wine Captain® Models, Combo® Models, a Refrigerator / Freezer, Refrigerators, Drawers and Beverage Centers. The U-Line brand offers products in the 1000 Series, 2000 Series and the Modular 3000 Series. The 1000 Series offers a more targeted priced product with appropriate features, while the 2000 Series offers upscale features, advanced technology and specialized product families. U-Line's approach to its breadth of products, multiple price points and features allows a choice and product that will fit any lifestyle.

Read and save this Use and Care Guide.

NOTICE

READ all instructions in this guide completely before using the appliance for the first time.

For future reference, keep this guide in a safe, accessible location. If you need additional information or assistance, please contact U-Line Corporation direct. Contact information appears on the back cover of this guide.

Before Calling Service. If you think your U-Line product is malfunctioning, read the OPERATION section of this guide to understand clearly the function of the control. If the problem persists, read the TROUBLESHOOTING GUIDE section of this guide to help you quickly identify common problems, and provide information on possible causes and remedies.

Please Record Your Model Information

You will need your product model and serial number when you request additional information or services. You can find this information on the serial plate located on the upper right or back wall in the interior of your product. This information also appears on the warranty registration card. Please complete and mail your warranty registration card. You may also register online at www.u-line.com



Please record the model number (1), serial number (2), date of purchase, and dealer contact information for your U-Line product below:

Model Number:

Serial Number:

Purchase Date:

Dealer Name:

Dealer Address:

Dealer Telephone:

Table of Contents

Safety Precautions	
Safety Alert Definitions	1
General Precautions	1
Dual Zone Product Features	
Models Covered:	2
Wine Captain® Dual Zone Features:	2
Wine Captain® Dual Zone Additional Features:	2
Product Operation	
Air Flow	3
Initial Startup	3
Electronic Control Panel	3
Dual Temperature Zones	3
Checking Product Temperature	4
Interior Lighting	4
Electronic Control Quick Guide	5
U-Line Wine Guide	
Looking Behind the Label	6
Wine Selections Suggestions	6
Ideal Wine Storage Considerations	7
Wine Stocking Recommendation	8
Wine Rack Removal and Installation	8
Wood Trim Finishing	9
Maintenance	
Light Bulb Replacement	10
Leveling	10
Removing and Installing Grille	10
Wine Rack Removal/Installation	11
Self-Closing Doors	
Door Alignment and Adjustment	12
Door Reversability	12
Reversing Stainless Steel Glass Doors	12
Reversing the Door	14
Cleaning	
Exterior Cleaning	16
Interior Cleaning	16
Defrosting	16
Condenser Cleaning	17
Storage, Vacation and Moving	17
Product Disposal	17
Service	
Before Calling for Service	18
If Service is Required	18
Replacement Parts	18
Normal Operating Sounds	18
Troubleshooting Guide	18

Safety Precautions

NOTICE

- **PLEASE READ** all instructions before installing, operating, or servicing the appliance.
- Proper installation procedures must be followed when completing an installation or relocation of a unit. An **INSTALLATION GUIDE** for the unit, providing complete installation information, is available from U-Line Corporation direct. Consult the installation guide before any installation begins. U-Line contact information appears on the rear cover of this guide.
- This unit requires connection to a dedicated 15 Amp grounded (three-prong), polarized receptacle, installed by a qualified electrician, compliant with applicable electrical codes.

Safety Alert Definitions

Throughout this guide are safety items labeled with a Danger, Warning or Caution based on the risk type:

DANGER

Danger means that failure to follow this safety statement will result in severe personal injury or death.

WARNING

Warning means that failure to follow this safety statement could result in serious personal injury or death.

CAUTION

Caution means that failure to follow this safety statement may result in minor or moderate personal injury, property or equipment damage.

General Precautions

Use this appliance for its intended purpose only. Follow these general precautions with those listed throughout this guide:

DANGER

RISK OF CHILD ENTRAPMENT. Before you throw away your old refrigerator or freezer, take off the doors and leave shelves in place so children may not easily climb inside.

WARNING

SHOCK HAZARD - Electrical Grounding Required.

- Never attempt to repair or perform maintenance on the unit until the electricity has been disconnected.
- Never remove the round grounding prong from the plug and never use a two-prong grounding adapter.
- Altering, cutting of power cord, removal of power cord, removal of power plug, or direct wiring can cause serious injury, fire and or loss of property and or life, and will void the warranty.
- Never use an extension cord to connect power to the unit.
- Always keep your working area dry.

WARNING

Install provided Anti-Tip kit. Serious personal injury could occur.

CAUTION

- Use care when moving and handling the unit. Use gloves to prevent personal injury from sharp edges.
- If your model requires defrosting, **DO NOT** use an ice pick or other sharp instrument to help speed up defrosting. These instruments can puncture the inner lining or damage the cooling unit. **DO NOT** use any type of heater to defrost. Using a heater to speed up defrosting can cause personal injury and damage to the inner lining.

NOTICE

- Do not lift unit by door handle.
- Never install or operate the unit behind closed doors. Be sure front grille is free of obstruction. Obstructing free airflow can cause the unit to malfunction and will void the warranty.
- Failure to clean the condenser every six months can cause the unit to malfunction. This could void the warranty.
- Do not Block any internal Fans.

Use only genuine U-Line replacement parts. Imitation parts can damage the unit, affect its operation or performance and may void the warranty.

Dual Zone Product Features



Models Covered:

U-2275ZWCOL-00 U-2275ZWCS-00
U-2275ZWCOL-60 U-2275ZWCS-01

Wine Captain® Dual Zone Features:

Independently controlled Temperature Zones. Temperature in each zone can be set independently between 34° - 60°F, providing different storage options.

Touch Sensitive Digital Controls. Provides ability to set and see the temperature. Manages key model functions and provides user alerts.

Black interior. Elegant visual appearance.

Sabbath or “Black Out” mode. Easily turns off all lights and control displays.

Vinyl-clad cabinet. Textured, rich appearance. More resistant to scratching, peeling and flaking.

Contemporary grille design. Blends with the other models and integrates with surrounding cabinetry.

Stainless steel model. Offers a bold stainless steel handle, stainless steel wrapped door.

Overlay Model. A custom overlay frame may be installed to seamlessly match surrounding decor.

Open door alarm. Audible alert when door is left open.

Adjustable leveling legs. Achieve a more precise under counter fit. Durable, strong legs will not bend when unit is installed.

Defrost Type: Automatic (cycle) Defrost

Adjustable on/off interior light. Automatically illuminates when the door is opened. May be manually turned on when door is closed for viewing one's wines. Auto shut-off after four hours. Recessed so as not to interfere with access to wine.

Low-E coated, gas filled thermal glass door. Allows for effective product presentation. Protects wine and other products from potentially harmful ultraviolet light rays.

Full extension slide-out coated wine racks. Allow for easy access to all wine bottles. Four or eight wine bottle capacity (0.75 L) on each rack.

Wood trimmed wine racks. Wood can be stained or replaced with a solid surface material to match surrounding décor.

For indoor use only.

Wine Captain® Dual Zone Additional Features:

Capacity. Wine Captain® Dual Zone can safely store up to 43 Bottles (.75L) of fine wines.

Built-in. Product designed for built-in look. No additional clearance around sides, top, or rear of unit for ventilation.

Stable temperatures. Stable, consistent temperatures provide longer-term storage capability.

Built-in. Provides custom look. No additional clearance around sides, top or rear of unit for ventilation. Do not obstruct front grille.

Black model. Offers a black elegant integrated handle and grille with a black vinyl-clad steel cabinet.

Product Operation

Air Flow

NOTICE

The unit requires proper air flow to perform at its highest efficiency. Do not block the front grille or internal fans at any time, or the unit will not perform as expected. Do not install the unit behind a door.

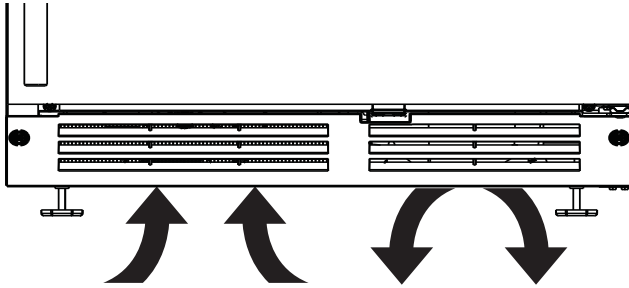

Initial Startup

All U-Line controls are preset at the factory. Initial startup requires no adjustments.

NOTICE

U-Line recommends allowing the unit to run overnight before loading refrigerator or freezer with product.

To turn the unit on or off, press and hold the POWER icon (1) for approximately five seconds and release. The display will show the unit set-point temperature when turned on and display OFF when the unit is off.

Electronic Control Panel

Digital Display. Dual Zone Wine Captain Models provide two controlled temperature zones to satisfy the specific storage requirements of your finest wines.

The dual electronic displays are configured to display current temperature set points for each zone. The top zone is displayed on the upper (3) display while the lower zone set point is shown on the lower (6) display. This set point is a base number used by the controller to maintain the multiple temperature zones in the unit. The factory default set-point for Wine Captain models is 50°F. The set-point temperature is a gauge for further temperature adjustments.

Dual Temperature Zones

To adjust the set point temperature:

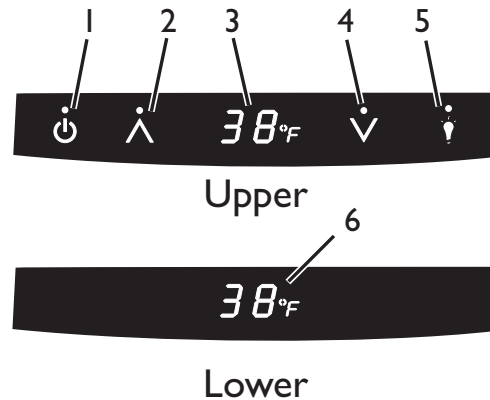

NOTICE

Adjust the set-point temperature in single increments and wait 24 hours for the temperature to stabilize.

Your unit has been designed to provide two temperature zones (upper and lower) in the cabinet.

1. Touch and release Warmer (2) to put the controller in the SET TEMPERATURE mode. The top of the F in “°F” will begin to flash. This will allow you to adjust the temperature of the top zone. After 10 seconds of inactivity, the bottom bar of the F in “°F” will begin to flash. This will allow you to adjust the temperature of the bottom zone. Adjustment to the lower zone can be made immediately if Light (5) is touched after entering Set Temperature mode.
2. While the top or bottom bar of the F in “°F” is flashing touch Warmer (2) or Cooler (4) as required to adjust the set-point temperature. The change will be committed five seconds after adjustment. The new set-point will be displayed.

Temperature °F °C Selection.

The display may be adjusted to allow for temperature display in either °F or °C.

Touch and hold LIGHT (5) and simultaneously within five seconds touch and release COOLER (4) three times to change the displays (3 & 6) as needed.

Temperature Display.

To display actual temperature:

1. Touch and hold WARMER (2) for approximately five seconds and release when “°F” begins to flash.
2. The displays (3 & 6) will show a readings for the displays respective zone.

Checking Product Temperature

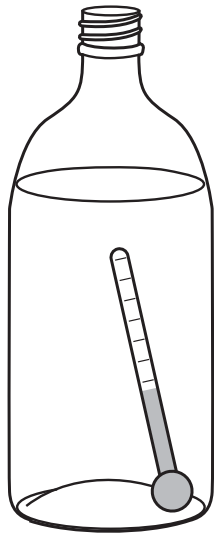

To check the actual product temperature in the unit.

1. Partially fill a plastic (nonbreakable) bottle with water.
2. Insert an accurate thermometer.
3. Tighten the bottle cap securely.
4. Place the bottle in the desired area for 24 hours.
5. Avoid opening the unit during the testing period.
6. After 24 hours, check the temperature of the water. If required, adjust the temperature control in a small increment (See ADJUSTING TEMPERATURE).

Causes which affect the internal temperatures of the cabinet include:

- Temperature setting.
- Ambient temperature where installed.
- Installation in direct sunlight or near a heat source.
- The number of door openings and the time the door is open.
- The time the internal light is illuminated. (This mainly affects product on the top rack or shelf.)
- The front grille or condenser are obstructed.

Interior Lighting

Normal Operation. Opening the door will cause the interior of the cabinet to illuminate.

Use the LIGHT icon (5) on the control panel to change the lighting functions.

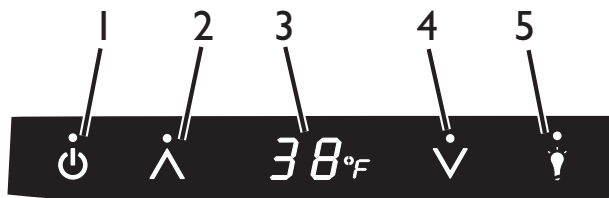

Timed Lighting. The interior of the cabinet is illuminated for a timed four-hour period.

1. Press and release the LIGHT icon (5) (the °F symbol will flash briefly) to switch from door-operated lighting control to the timed four hour lighting period.
2. At the end of the four-hour period, the light will turn OFF and door-operated lighting control will resume.
3. To exit the timed lighting control before the end of the four-hour period, repeat Step 1.















Blackout (Sabbath) Mode. The interior of the cabinet and control display remains darkened for a 36-hour period (Blackout (Sabbath) Mode is not Star K certified).







To turn the lights and display OFF for a preset 36-hour interval.

1. Press and hold the LIGHT icon (5) for 10 seconds and release (the °F symbol will flash briefly at the end of the ten second period).
2. The interior light and control display will go dark for the next 36 hours.
3. NOTE: Although the display will not be visible, the temperature controls in the unit remain active, and preserve the interior temperature.

To exit the Blackout (Sabbath) Mode before the 36-hour period, repeat Step 1.

Electronic Control Quick Guide

Task	Touch	Touch	Display	Comment
Turn ON/OFF	 Hold 5 seconds	Release when °F flashes.	 or 	
Adjust Temperature	 Touch and release	 or  Touch to change temperature		°F flashes after first touch, set-point saved after 5 seconds of inactivity and °F stops flashing.
View Actual Temp	 Hold 5 seconds	Release when °F flashes.		WC models will scroll top/mid/bottom temps.
Change F/C	 Hold		 or 	
Blackout Mode	 Hold 10 seconds		Display (and cabinet light) will not operate in Blackout Mode.	Blackout will end in 36 hours, or hold again to terminate early.

Glass Door Models Only				
Cabinet Light				Light normally goes on/off with door opening. Pressing light icon will turn interior light on for 4 hours, then it will turn off.
Display Off Mode		  		Display off when door is closed (unless cabinet light is turned on). Repeat to switch back.

NOTE: 38°F is an example; the display will vary with actual set-point.

U-Line Wine Guide

Looking Behind the Label

To most, wine is a delicious mystery. We purchase it, uncork it, and savor its taste and beauty. But there is so much more to true wine appreciation. Many secrets are simply too good to keep bottled up.

Wine Selections Suggestions

Selecting the right wine for the right occasion can sometimes be a seemingly awkward or difficult task for the beginning wine enthusiast. We would therefore like to present you with a few suggestions which may provide a little more confidence and enjoyment when choosing and serving your wines.

When selecting wines, keep an open mind and do not be afraid to be adventurous. Do not view the subject of wine so seriously it discourages you from learning and discovering for fear of embarrassment if something is incorrect. Wine is best viewed as a hobby and enjoyed.

When assembling your collection, try not to become obsessed with "Vintages." Although a chart can be a useful tool, generalizations about a specific year have led more than one collector to disappointment. Often an "Off Year" will provide a better value and more drinking enjoyment.

The primary guideline to the subject of wine is your own palate. Do not be afraid to make mistakes. Experiment, discover, but most of all, enjoy yourself and your new U-Line product.

Guide To Common Styles Of Wine

Red Wines		
Full-Bodied Dry	California French Italian	Zinfandel, Cabernet Rhone, Chateauf-neuf-du-Pape Barbaresco, Barolo
Medium-Bodied Dry	California French	Pinot Noir Bordeaux, Burgundy
Light-Bodied Dry	French Italian	Beaujolais Chianti, Bardolino
White Wines		
Full-Bodied Dry	California French	Chardonnay Montrachet, Meursault Puligny-Montrachet
Medium-Bodied Dry	California French	Sauvignon-Blanc Pouilly-Fuisse, Sancerre, Vouvray, Graves
Light-Bodied Dry	French	Chablis, Muscadet, Pouilly-Fume
Full-Bodied, Very Sweet	Germany France Hungary	Beerenauslese Sauternes Tokay
Medium-Bodied, Semi-Sweet	California Germany	Gewurtztraminer Liebfraumilch
Light-Bodied Off Dry	Germany	Rhine, Mosel, Riesling

Matching Food and Wine

Although there are no hard fast rules for matching wine to food, observe some guidelines. Delicate dishes should be accompanied by lighter more delicate wines. Full-flavored foods should be matched with fuller-bodied wines.

As a general rule, one should aim to ascend in flavor and quality of wines served.

Serve a:	Before a:
DRY wine	SWEET wine
WHITE wine	RED wine
YOUNG wine	OLD wine
LIGHT-BODIED wine	FULL-BODIED wine

Any step back in quality will be noticed. If a fine wine is tasted prior to a lesser wine, many of the fine wine's subtle qualities may be missed.

Common Food and Wine Matches

Foods	Wines
Fish, Shell Fish, Crab, Oysters	Dry White Wines, Light Sparkling or Extra Dry Champagne
Beef, Venison	Full-Bodied Red Wines
Pork, Veal, Lamb and Poultry	Light-Bodied Red Wines
Fruit	Sweet White and Sparkling Wines

A Toast to Wine Truths

Like the grapes themselves, many wine myths have been cultivated over the centuries.

Myth 1: Most wines taste better when aged.

Truth: In fact, less than 5% of wines produced today are meant to be aged. Most wines are crafted to be consumed within the first one to two years.

Myth 2: Wines should be uncorked and decanted allowing them to "breathe."

Truth: To breathe or not breathe? While it is better to allow a young tannic Red to breathe in a glass or decanter to soften the tannins, an old Red reaches a stage in its life where it should be enjoyed soon after opening. Allow an old Red to breathe for a short time to dissipate any off odors. Most white wines can be served, ideally, 10-15 minutes after opening.

Myth 3: When age worthy wines peak, they must be consumed almost immediately.

Truth: Most great wines reach a plateau period rather than a peak. Great Bordeaux may have as much as a 10-year plateau before fading.

Myth 4: Wine color does not change with aging.

Truth: As red wines age they get lighter in color while whites get darker.

The Cork: A Mystery on Its Own.

Cork Presentation. The ritual of the presentation of the cork has a rich and fascinating history dating back to the late 1800's. A phylloxera (root louse) devastation to the vineyards severely limited the supply of great wines. Restaurateurs would remove labels on inferior wines and replace them with labels from superior wines. This made it necessary for patrons to protect themselves by checking the branding on the cork to ensure that what they ordered was, in fact, what they were served.

When presented with a cork today, feel it to check for its integrity, read and match the branding on the cork to the bottle and set it aside. There is little to be learned from the cork. The proof is in the wine.

“Corked” wines. If you've ever had a wine that smelled or tasted of mold, you've experienced a wine that may have been “corked”. Today, between five and eight percent of wines are tainted with Trichloroanisole (TCA). This substance, found naturally in plants and trees, is imparted to the wine through the cork. Corked wines are a major concern for winemakers as it destroys millions of cases per year and puts reputations at stake. Amazing as it may seem twist-off caps may offer a better alternative and many great wineries in California, Australia and New Zealand are pioneering the trend.

Common Tasting Terms

Terminology	Description
Acidity	A critical element of wine that is responsible for preserving the wines freshness. Excess acidity results in an overly tart and sour wine.
Balance	A desired trait where tannin, fruit and acidity are in total harmony. Wines with good balance tend to age gracefully.
Body	The weight and presence of wine in the mouth provided by the alcohol and tannin level. Full-bodied wines tend to have this strong concentration.
Bouquet	The blending of a wine's aroma within the bottle over a period of time, caused by volatile acidity.
Complex	A subjective term often used in tasting. A wine is said to be complex if it offers a variety of flavors and scents that continue to evolve as it develops.
Flabby	A wine that lacks structure, or is heavy to the taste, lacks acidity.
Full-Bodied	Wine high in alcohol and extract, generally speaking, fills the mouth, powerful.
Lean	Generally describes wines that are slim, lacking of generosity or thin.
Oaky	A desirable flavor imparted to wine if done in moderation. Most wines are aged in oak barrels one to three years, thereby receiving this toasty oak characteristic. However, if a weak wine is left in contact too long with an oak barrel it will tend to be overpowered with an oaky taste.
Tannin	Tannins are extracted from the grape skins and stems and are necessary for a well-balanced red wine. Tannins are easily identified in wine tasting as the drying sensation over the gums. Tannins generally fade as a wine ages.

Ideal Wine Storage Considerations

Temperature: The most important element about storage temperature is stability. If wine is kept in a stable environment between 40°F and 65°F, it will remain sound. A small 1-2 degree temperature fluctuation within a stable environment is acceptable. Larger temperature fluctuations can affect the corks ability to seal, allowing the wine to “leak” from the bottle.

Humidity: The traditional view on humidity maintains that wines should be stored on their sides in 50% - 80% relative humidity to ensure cork moisture and proper fit in the bottle. Contemporary wisdom suggests that the cork surface is too small to be impacted by humidity. Further the cork is sealed with a metal or wax capsule making humidity penetration impossible. The concept of a humid storage environment was derived from the necessity of wineries to maintain moisture in their cellars to keep wooden barrel staves swollen, preventing wine evaporation and product loss. In fact, vineyards estimate as much as a 10% product loss per year due to evaporation while wine is aging in the wooden barrels. Humidity, however, was not intended for the modern home cellar where wine is stored in glass bottles with sealed corks.

Light: UV rays are not only harmful to people, they are damaging to wines - especially those in clear bottles. Since oxygen molecules in wine absorb UV rays, wine should never be stored in direct light for long periods of time.

Vibration: Provided that sediment is left undistributed and particles are not suspended, vibration in a storage environment is not an issue. Wines can become flat or tired when voids and vacuums are created inside the wine bottle. In order to create voids and vacuums within a liquid, aggressive motion or shaking of the wine bottle would have to occur.

The Right Temperature for Wine

Temperature	Wines
Approximately 60°F (15°C)	Red
50°F - 55°F (10°C - 12°C)	White
Approximately 45°F (7°C)	Sparkling

Wine Captain® Models - A Touch of Elegance

In 1985 U-Line was the first North American appliance manufacturer to develop a residential wine storage unit, the Wine Captain®. Each U-Line Wine Captain® model is designed to impress and inspire anyone with an interest in wine by providing cellar conditions in stylish, undercounter units. U-Line Wine Captain® models offer stable storage temperatures, a 50% internal relative humidity and protection from UV light rays. U-Line has the largest product offering available, making storing, presenting, and sharing your wine effortless and elegant.

Wine Stocking Recommendation

Specially designed horizontal wine racks properly position the bottles so the wine remains in contact with the cork and ensure the cork does not become dry.

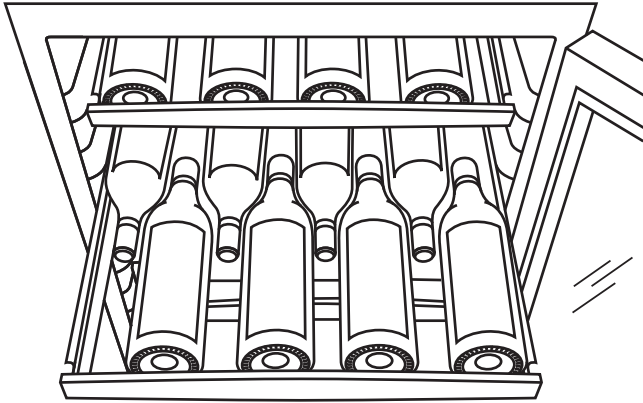

Stock the unit as follows:

1. Stock the wine racks beginning with the lowest rack, at the back, and working forward. Stagger the bottles as shown.
2. Repeat Step 1 to stock the next higher rack, and continue until all racks are filled.

NOTE: After stocking, allow unit to run 24 hours to stabilize product temperatures.

Wine Rack Removal and Installation

To remove a rack from the cabinet:

1. Remove any bottles stored on the rack.
2. Grasp the end of the rack, and gently slide it out until it stops.

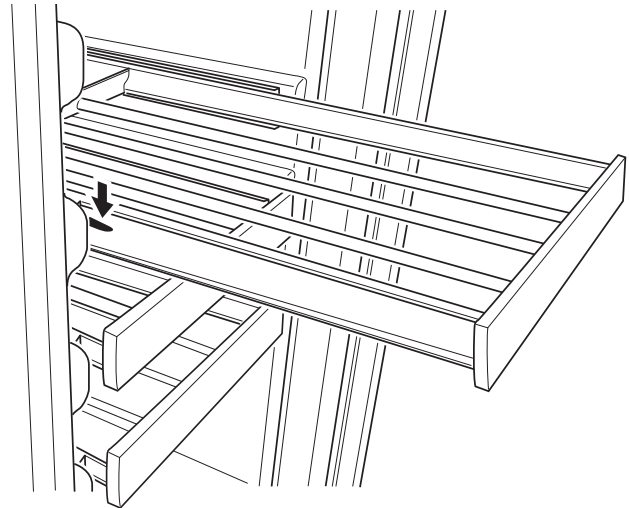

3. Press the left rack release lever down. At the same time, lift the matching right rack release lever up. Pull the rack out until it is free of the tracks and the cabinet.

NOTICE

Do not remove the track rails from the cabinet.

To insert a rack in the cabinet:

Align the left and right rack channels with the tracks in the cabinet. Ensure an even track engagement on both sides by gently pushing the rack into the cabinet until it stops.

Before reloading the rack, ensure proper movement of the travel stops in the left and right track rails by pulling the rack out gently until it stops.

Wood Trim Finishing

CAUTION

You **MUST** remove the wood trim from the unit for staining or finishing to prevent permanent damage to the inner liner of the unit. Allow stain or finish to dry thoroughly (at least 24 hours for each coat) following the product manufacturer's instructions before reinstallation. Not following this warning may cause the inner liner of the unit to have a permanent odor, which the warranty will not cover.

U-Line products featuring wine storage include wood-trimmed wine racks.

Models with wood colored wood trim come factory coated with a clear vinyl sealer without a finish coat applied, which will sufficiently protect the wood in normal use. You may coat the trim on the racks with stain or a final finish following these guidelines. If using custom wood trim also follow these guidelines.

If staining the trim, stain before applying any final finish. Review the following staining and final finish application and final finish-only application guidelines when staining or sealing the wood to ensure proper adhesion and durability of the finish.

NOTE: On glass door models the stain may appear darker when viewed through the glass.

Staining and final finish application:

NOTICE

DO NOT use oil-based stains on wood trim. Vapors from oil-based stains will permanently penetrate the liner and will not dissipate over time.

1. Remove all screws securing wood trim to interior parts, and remove the trim from the cabinet interior.
2. Lightly sand and clean wood.
3. Apply Minwax® Water-Based Wood Stain to wood with a synthetic bristle brush or a foam applicator. Allow stain to penetrate about three minutes. Before the stain is dry, take a stain dampened rag and remove any excess stain remaining. Wipe towards the grain with medium pressure to achieve the desired stain color.
4. After two hours, repeat step 2. This will even out the color of the wood.
5. Allow stain to dry for a minimum of three hours before applying the final finish.
6. If desired, sand the wood with very fine sandpaper to smooth the surface after staining.
7. Remove all dust from the wood, and apply one coat of Minwax® Polycrylic® Protective Finish using a synthetic bristle brush. Apply this finish in a thin coat following the grain. Apply the finish to the back and sides of the wood first, and allow it to dry for two hours. Apply the finish to the front side of the wood next, and allow it to dry for two hours. Sand with 220 grit sandpaper. Apply two more coats of finish in the same manner, but do not sand the trim after applying the final third coat.
8. Allow the final coat to dry for 24 hours before reinstalling the trim to the cabinet interior parts.

Final finish-only application:

1. Remove all screws securing wood trim to interior parts, and remove the trim.
2. Lightly scuff sand the wood trim with 280 or finer grit sandpaper.
3. Remove sanding dust with a clean, dry cloth.
4. The factory-applied seal is compatible with almost all finishes. A low odor, water clean up, quick-drying finish such as Minwax® Polycrylic® Protective Finish is recommended (Minwax® Polycrylic® is an ultra fast-drying water-based finish). Apply a thin coat of a clear, protective finish, following the container label directions.
5. Lightly sand and reapply if desired.

Allow the final coat to dry for 24 hours before reinstalling the trim to the cabinet interior parts.

Maintenance

Light Bulb Replacement

To replace the light bulb in your U-Line unit:

1. Find the light located at the top of the unit. Grasp the edges of the light housing lens (1) opposite the exposed tab and gently push the lens toward the tab (2).
2. Pull the edge of the lens down (1) and swing it out of the light housing.

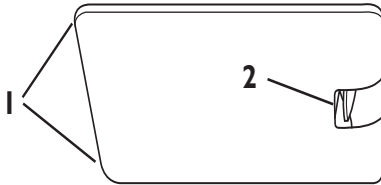

NOTICE

ALWAYS use a genuine U-Line replacement 120V 10 watt bulb (Part Number 31317) in the light housing. Use of any other bulb within the housing will produce excessive heat, causing damage to the light housing and cabinet interior, and will compromise the precise temperature control of the unit.

1. Replace the lens by first inserting the tab side back into the housing at a slight angle.
2. While gently pushing the lens towards the tab end, push the free end into the housing, and release when you hear a snap.

Leveling

NOTICE

Unit must be level, for proper door and ice maker (if equipped) operation.

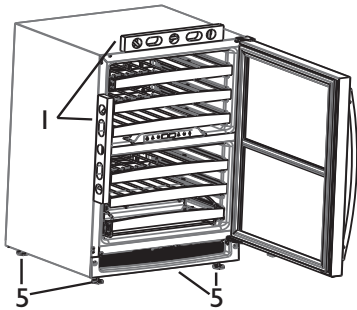

For Models with adjustable leveling feet:

1. Use a level to check the levelness of the unit from front to back and from side to side. Place the level along top edge and side edge as shown (1).
2. If the unit is not level, rotate the adjustable leveling legs to raise or lower each corner of the unit (5) as necessary.
3. Check levelness after each adjustment and repeat the previous steps until the unit is level.

Removing and Installing Grille

⚠ WARNING

Disconnect electric power to the unit before removing the grille.

⚠ WARNING

DO NOT touch the condenser fins (4). The condenser fins are SHARP and can be easily damaged.

Removing the grille.

1. **Disconnect power to the unit.**
2. Remove control knob (6) if equipped.
3. Loosen the two screws (1). Some models may have only one screw in the center.
4. Remove grille (2) and grille cap (if equipped)(3) from unit.

Installing the grille:

1. For 15 and 29 models make sure grille cap (3) is behind grille in slots (2) provided in grille before attaching grille to unit.
2. For 75 models place the hook-hinge located on the rear bottom side of the grille (2) onto the front lip of the unit base. Swing the grille up into position.
3. Align cabinet and grill holes and secure, but do not overtighten grille screws (1).
4. Install control knob (6) if equipped.
5. Reconnect power to the unit.

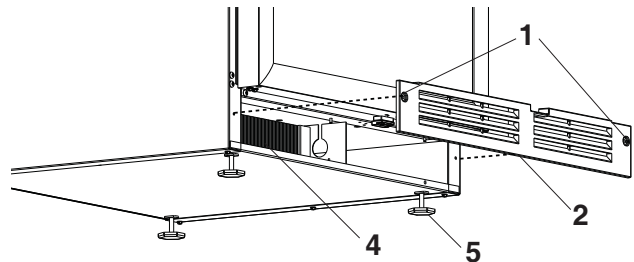

Typical Model Shown

Wine Rack Removal/Installation

To remove a rack from the cabinet:

1. Grasp the end of the rack, and gently slide it out until it stops.
2. Remove any bottles stored on the rack.
3. Press the left rack release lever (**Figure 1**) down, and at the same time, lift the corresponding right rack release lever up, and pull the rack out until it is free of the tracks and the cabinet.

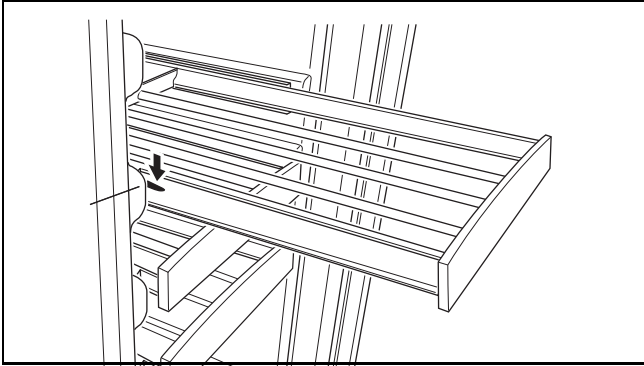

Figure 1. Rack Removal/Installation

NOTICE

Do not remove the track side rails from the cabinet.

To insert a rack in the cabinet:

1. Align the left and right rack channels with the tracks in the cabinet, and ensuring an even track engagement on both sides, gently push the rack into the cabinet until it stops.
2. Before reloading the rack, ensure proper operation of the travel stops in the left and right track rails by pulling the rack out gently until it completely stops.

Self-Closing Doors

Door Alignment and Adjustment

Align and adjust the door if it is not level, or is not sealing properly. If the door is not sealed the unit may not cool properly, or excessive frost may form in the interior.

NOTICE

- Properly aligned, the door's gasket should be firmly in contact with the cabinet all the way around the door (no gaps). Carefully examine the door's gasket to assure that it is firmly in contact with the cabinet. Also make sure the door gasket is not pinched on the hinge side of the door.
- The door will not be flush with the top of the cabinet. The top edge of the door will be 1/8 in. (3.175 mm) below the cabinet top.

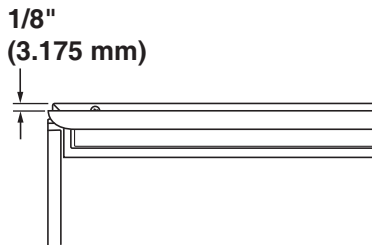

To align and adjust the door:

1. Compare the top edge of the door (opposite the hinges) to the top edge of the cabinet and note the type (up or down) of adjustment needed.

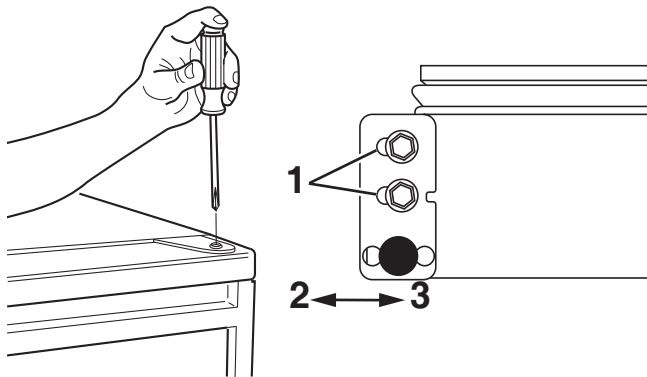

2. Remove the top hinge pivot pin with a Phillips screwdriver and lift door off bottom hinge pin. Be careful not to lose the door closer insert sets.
3. Turn the door upside down and inspect the hinge plate mounting holes. The plate has slotted mounting holes. Loosen but do not remove the two hinge plate screws (1).
4. If door edge opposite the hinges needs to move up, move plate toward outside of door (2). If door edge needs to move down, move plate toward inside of door (3). Repeat until top edge of door is parallel with top of cabinet and tighten screws (1) securely.

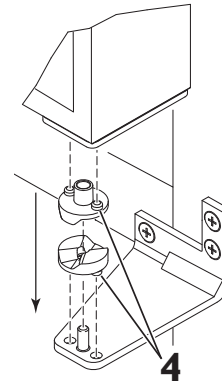

5. After adjustment is complete, remove the door closers from the bottom hinge, clean thoroughly and apply petroleum jelly to the mating surfaces of the closers. Be sure that pins on closers align with holes in the door and bottom cabinet hinge plates. Mount door and install top hinge pivot pin.

Door Reversability

Location of the unit may make it desirable to mount the door on the opposite side of the cabinet.

Reversing Stainless Steel Glass Doors

Remove Door

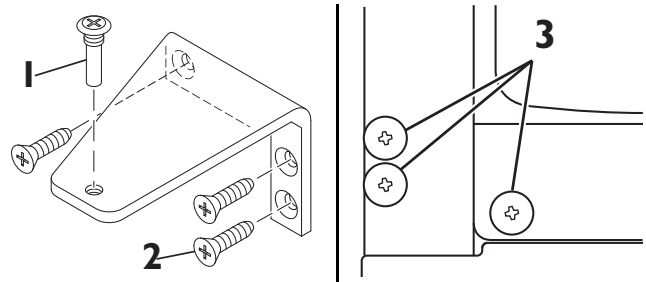

1. Hold door to keep it from falling.
2. Remove hinge screw pin (1) from top hinge using a Phillips screwdriver.
3. Remove door by tilting forward and lifting door off bottom hinge closer inserts.
4. Reinstall hinge screw pin (1) into top hinge using a Phillips screwdriver.

Remove Hole Plugs

1. Remove plastic screw plugs from (three each, top and bottom) (3) from new hinge location. Save for reinstallation later.

Remove Stainless Frame

1. Remove two screws from top of door. Save screws for later installation.

Top Of Door

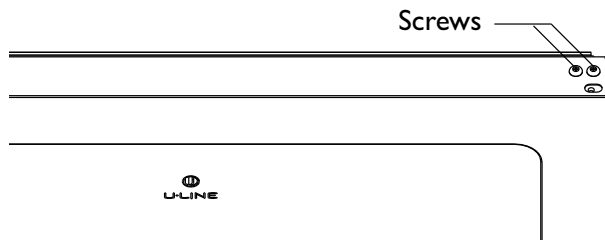

2. Remove pivot plate from bottom of door by removing 2 screws. Set pivot plate and screws aside for later installation.

Bottom Of Door

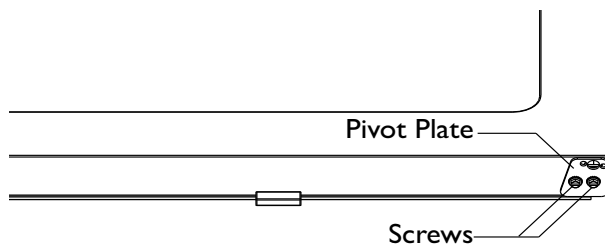

3. Grasp outer edge of stainless frame and firmly press inside edge of glass in while pulling stainless frame in opposite direction.

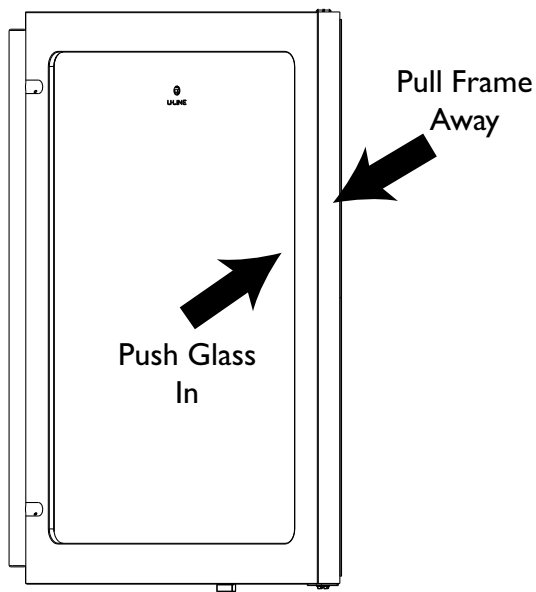

4. Unhinge frame from door.

Assemble Stainless Frame

1. Prop frame against solid surface, handle side down and away.
2. Insert door, logo forward, into frame at a 30° angle. For a right hand hinge the logo should be to your right. For a left hand hinge the logo should be to your left.

Door Orientation Right Hand Hinge

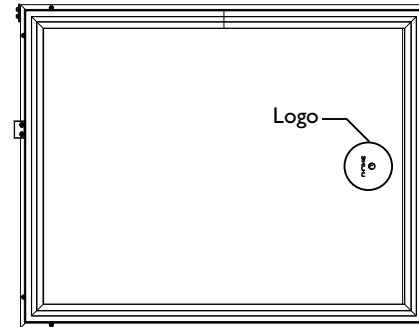

Door Orientation Left Hand Hinge

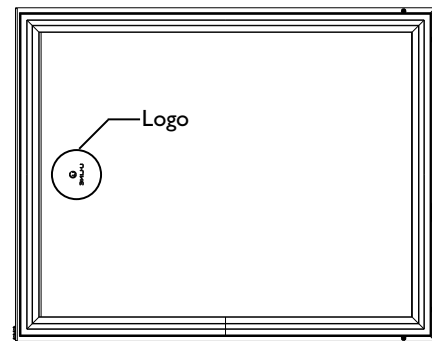

3. Swing door into frame.
4. Install screws removed in "Remove Stainless Frame" step 1 to top of door, opposite handle.
5. Install pivot plate to bottom of door, opposite of handle, using hardware removed in "Remove Stainless Frame" step 2. Arrange pivot plate so the flat edge is against the edge of the door.

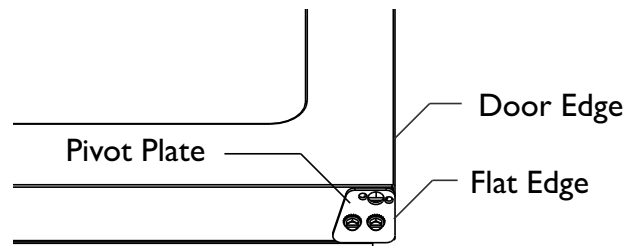

Orient Hinges

1. Remove existing top hinge (three screws) (2).

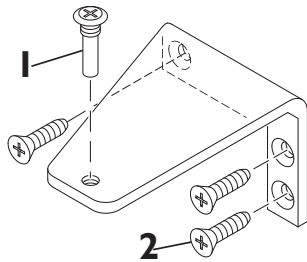

Reinstall hinge to bottom opposite.

1. Install the hinge just removed from the top to the **BOTTOM** opposite side of the cabinet (three screws) (2).
2. Remove the two door closer inserts (4) from the preexisting bottom hinge.

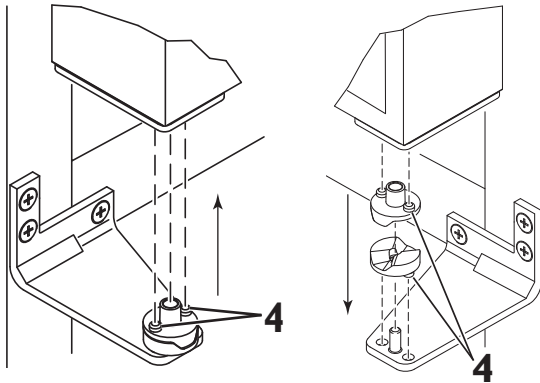

3. Install door closer inserts as shown on the new bottom hinge (4).

Remove existing bottom hinge.

1. Remove the existing bottom hinge (three screws) (2).

Reinstall hinge to top opposite.

1. Install the hinge just removed from the bottom to the **TOP** opposite side of the cabinet (three screws) (2).

Reinstall Hole Plugs

1. Install plastic screw plugs (three each, top and bottom) (3) into holes where hinge hardware was removed.

Install Door

1. Hold door upright and tilted forward.
2. Lift door on to bottom hinge closer inserts.
3. Tilt door forward into position.
4. Hold door to keep it from falling.
5. Reinstall hinge screw pin (1) into top hinge using a Phillips screwdriver.

Align and adjust the door:

Align and adjust the door, see **DOOR ALIGNMENT AND ADJUSTMENT** on page 12.

Reversing the Door

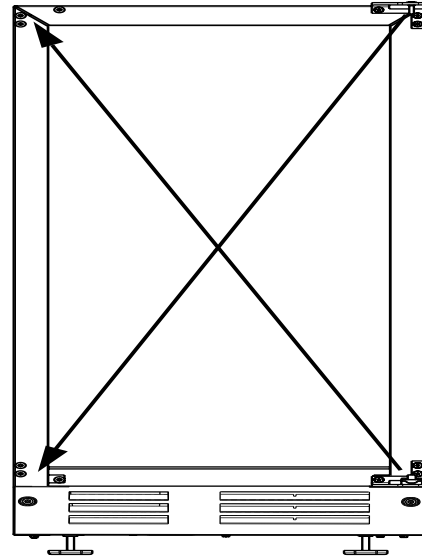

The hinge hardware will be removed and reinstalled on the opposite side of the cabinet.

The top hinge hardware will be reinstalled on the bottom of the opposite side of the cabinet.

The bottom hinge hardware will be reinstalled on the top of the opposite side of the cabinet.

To reverse the door:

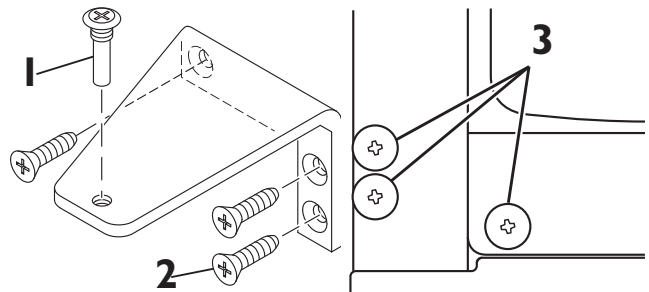

Remove door.

1. Hold door to keep it from falling.
2. Remove hinge screw pin (1) from top hinge using a Phillips screwdriver.
3. Remove door by tilting forward and lifting door off bottom hinge closer inserts.
4. Reinstall hinge screw pin (1) into top hinge using a Phillips screwdriver.

Remove hole plugs.

Remove plastic screw plugs (three each, top and bottom) (3) from new hinge location. Save for reinstallation later.

Remove existing top hinge.

Remove existing top hinge (three screws) (2).

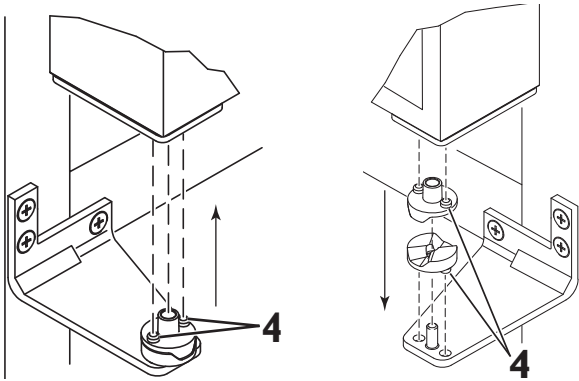

Reinstall hinge to bottom opposite.

1. Install the hinge just removed from the top to the **BOTTOM** opposite side of the cabinet (three screws) (2).
2. Remove the two door closer inserts (4) from the existing bottom hinge.
3. Install door closer inserts as shown on the new bottom hinge (4).

Remove existing bottom hinge.

Remove the existing bottom hinge (three screws) (2).

Reinstall hinge to top opposite.

Install the hinge just removed from the bottom to the **TOP** opposite side of the cabinet (three screws) (2).

Reinstall hole plugs.

Install plastic screw plugs (three each, top and bottom) (3) into holes where hinge hardware was removed.

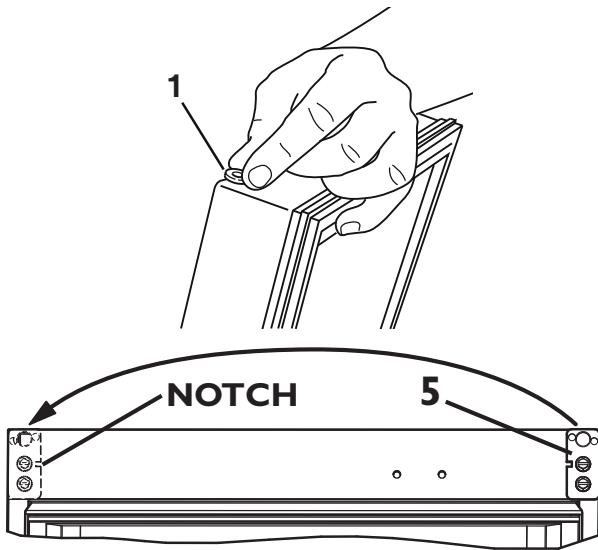

Prepare door for reinstallation.

1. Remove plastic hole plug from top of door handle and reinstall on opposite side.
2. With bottom of door facing up, remove pivot plate (5) (two screws).
3. Flip over and install pivot plate on opposite side of door. Ensure notch in plate faces center.

Install door.

1. Hold door upright and tilted forward.
2. Lift door on to bottom hinge closer inserts.
3. Tilt door forward into position.
4. Hold door to keep it from falling.
5. Reinstall hinge screw pin (1) into top hinge using a Phillips screwdriver.

Align and adjust the door:

Align and adjust the door, see **DOOR ALIGNMENT AND ADJUSTMENT** on page 12.

Cleaning

Exterior Cleaning

Vinyl Clad (Black or White) Models:

- Clean surfaces with a mild detergent and warm water solution. Do not use solvent-based or abrasive cleaners. Use a soft sponge and rinse with clean water. Wipe with a soft, clean towel to prevent water spotting.
- Clean any glass surfaces with a non-chlorine glass cleaner.

Stainless Models:

- Stainless door panels, handles and frames can discolor when exposed to chlorine gas, pool chemicals, saltwater or cleaners with bleach.
- Keep your stainless unit looking new by cleaning with a good quality all-in-one stainless steel cleaner polish monthly. For best results use Claire® Stainless Steel Polish and Cleaner, which can be purchased from U-Line Corporation (Part Number 173348). Comparable products are acceptable. Frequent cleaning will remove surface contamination that could lead to rust. Some installations may require cleaning weekly.
- **Do not clean with steel wool pads.**
- **Do not use stainless steel cleaners polishes on any glass surfaces.**
- Clean any glass surfaces with a non-chlorine glass cleaner.
- **Do not use cleaners not specifically intended for stainless steel on stainless surfaces (this includes glass, tile and counter cleaners).**
- If any surface discoloring or rusting appears, clean it quickly with Bon-Ami® or Barkeepers Friend Cleanser® and a nonabrasive cloth. Always clean towards the grain. Always finish with Claire Stainless Steel Polish and Cleaner or comparable product to prevent further problems.
- **Using abrasive pads such as ScotchBrite™ will cause the graining in the stainless to become blurred.**
- Rust not cleaned up promptly can penetrate the surface of the stainless steel and complete removal of the rust may not be possible.

Interior Cleaning

- **Disconnect power to the unit.**
- Clean the interior and all removed components using a mild nonabrasive detergent and warm water solution applied with a soft sponge or non-abrasive cloth.
- Rinse the interior using a soft sponge and clean water.
- **Do not use any solvent-based or abrasive cleaners.** These types of cleaners may transfer taste to the interior products and damage or discolor the interior.

Defrosting

Automatic Defrost Models

Frost on the rear wall is normal and will melt during each off cycle. If there is excessive build-up of 1/4" or more, manually defrost the unit.

- Ensure the door is closing and sealing properly.
- High ambient temperature and excessive humidity can also produce frost.

CAUTION

DO NOT use an ice pick or other sharp instrument to help speed up defrosting. These instruments can puncture the inner lining or damage the cooling unit. DO NOT use any type of heater to defrost. Using a heater to speed up defrosting can cause personal injury and damage to the inner lining.

NOTICE

The drain pan was not designed to capture the water created when manually defrosting. To prevent water from overflowing the drain pan, place towels or other absorbent materials over the interior drain trough, under the evaporator (1), before defrosting.

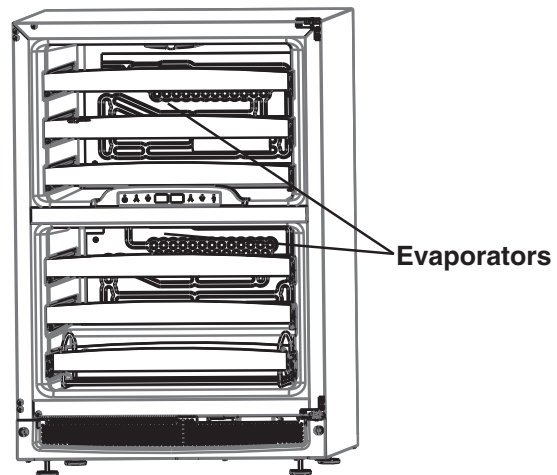

To defrost:

1. **Disconnect power to the unit.**
2. Remove all products from the interior.
3. Prop the door in an open position (2 in. (5 cm) minimum).
4. Allow the frost to melt naturally.
5. After the frost melts completely clean the interior and all removed components. (See INTERIOR CLEANING)
6. When the interior is dry, reconnect power and turn unit on.

Condenser Cleaning

Interval - Every Six Months

To maintain operational efficiency, keep the front grille free of dust and lint, and clean the condenser every three months. Depending on environmental conditions, more or less frequent cleaning may be necessary.

WARNING

Disconnect electric power to the unit before cleaning the condenser.

WARNING

DO NOT touch the condenser fins. The condenser fins are **SHARP** and can be easily damaged.

NOTICE

DO NOT use any type of cleaner on the condenser unit.

7. Remove the grill. (See MAINTENANCE)
8. Clean the condenser coil (4) using a using a soft brush with a “combing” action or vacuum cleaner. Do not touch the condenser coil.
9. Install the grill. (See MAINTENANCE)

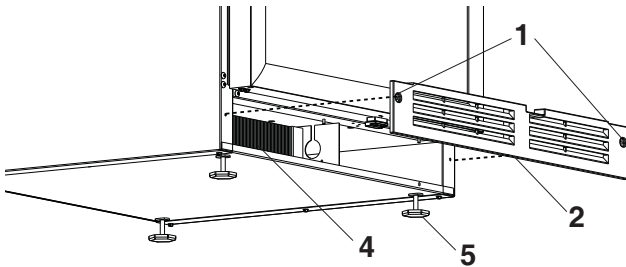

Typical Model Shown

Storage, Vacation and Moving

If not using the unit for an extended period, or otherwise stored, follow these steps completely:

WARNING

Electrical Shock Hazard. Disconnect power before servicing. Before operating, replace all panels. Failure to do so may result in death or electrical shock.

NOTICE

If the ambient temperature is expected to drop below 50°F, turn off and unplug unit, and drain all water from the unit to prevent freezing damage not covered by the warranty.

1. Remove all consumable contents from the unit.
2. Disconnect the power cord from its outlet, and leave it disconnected until the unit is returned to service.
3. Clean and dry the interior of the cabinet.
4. During periods of nonuse, the cabinet must remain open to prevent formation of mold and mildew. Open door a minimum of 2 in. (5 cm) to provide the necessary ventilation.

Product Disposal

If the unit is being removed from service for disposal, check and obey all Federal, State and or Local regulations regarding the disposal and recycling of refrigeration appliances, and follow these steps completely:

1. Remove all consumable contents from the unit.
2. Disconnect power to the unit and unplug the power cord from its outlet.

DANGER

RISK OF CHILD ENTRAPMENT. Before you throw away your old refrigerator or freezer, take off the doors and leave shelves in place so children may not easily climb inside.

3. Remove the cabinet door.

Before Calling for Service

If you think your U-Line product is malfunctioning, read the OPERATION section of this guide to clearly understand the function of the control.

If the problem persists, read the NORMAL OPERATING SOUNDS and TROUBLESHOOTING GUIDE section of this guide to help you quickly identify common problems, and possible causes and remedies. Most often, this will resolve the problem without the need to call for service.

If Service is Required

If you do not understand a troubleshooting remedy, or your product needs service, contact U-Line Corporation directly. Contact information appears on the rear cover of this guide.

When you call, you will need your product Model and Serial Numbers. This information can be recorded inside the front cover of this guide. It also appears on the Model and Serial number plate located on the upper right or rear wall of the interior of your product.

Replacement Parts

When you need replacement parts, always request genuine U-Line replacements. U-Line designs and engineers products using components that work efficiently, and provide superior service life and performance. The use of aftermarket parts or components may affect the safety, operation, performance or durability of your product, and may also void its warranty.

Normal Operating Sounds

All models incorporate rigid foam insulated cabinets to provide high thermal efficiency and maximum sound reduction for its internal working components. Despite this technology, your model may make sounds that are unfamiliar.

Normal operating sounds may be more noticeable because of the unit's environment. Hard surfaces such as cabinets, wood, vinyl or tiled floors and paneled walls have a tendency to reflect normal appliance operating noises.

Listed below are common refrigeration components with brief description of the normal operating sounds they make. NOTE: Your product may not contain all the components listed.

- Compressor: The compressor makes a hum or pulsing sound that may be heard when it operates.
- Evaporator: Refrigerant flowing through an evaporator may sound like boiling liquid.
- Condenser Fan: Air moving through a condenser may be heard.
- Automatic Defrost Drain Pan: Water may be heard dripping or running into the drain pan when the unit is in the defrost cycle.

Troubleshooting Guide



ELECTROCUTION HAZARD. Never attempt to repair or perform maintenance on the unit until disconnecting the main electrical power.

Troubleshooting - What to check when problems occur:

Problem	Possible Cause and Remedy
Digital Display and Light Do Not Work.	Ensure power is connected to the unit. If the unit is cooling, it may be in Blackout mode. (See OPERATION)
Interior Light Does Not Illuminate.	The light bulb may be defective. (See MAINTENANCE) If the unit is cooling it may be in Blackout mode. (See OPERATION)
Light Remains on When Door is Closed.	For glass door models, press the light icon and close the door. (See OPERATION) Check light actuator under door.
Unit Develops Frost on Internal Surfaces.	Frost on the rear wall is normal and will melt during each off cycle. If there is excessive build-up of 1/4" or more, manually defrost the unit. Ensure the door is closing and sealing properly. High ambient temperature and excessive humidity can also produce frost.
Unit Develops Condensation on External surfaces	The unit is exposed to excessive humidity, moisture will dissipate as humidity levels increase.
Digital Display Functions, But Unit Does Not Cool.	Ensure the unit is not in 'Showroom Mode'. Press and hold the COOLER icon and simultaneously within five seconds press the LIGHT icon three times to change the display as needed.
Digital Display Shows ER or E Followed By a Number.	E3 indicates the door may be opened too long, ensure the door is closing properly. For other error codes contact U-Line Customer Service.
Digital Display Shows 1-16 or 99	A factory test mode may be enabled. Adjust the temperature to 99 and press the LIGHT icon. (See OPERATION)
Product is Freezing.	Product in contact with the rear wall may freeze, ensure no product is touching the rear wall. Adjust the temperature to a warmer set-point. (See OPERATION)
Product is Not Cold Enough.	Air temperature does not indicate product temperature. See OPERATION - Checking Product Temperature. Adjust the temperate to a cooler set-point. (See OPERATION) Ensure unit is not located in excessive ambient temperatures or in direct sunlight. Ensure the door is closing and sealing properly. Ensure the interior light has not remained on too long. Ensure nothing is blocking the front grille, found at the bottom of the unit. Ensure the condenser coil is clean and free of any dirt or lint build-up.

PRODUCT INFORMATION

Complete Installation Guides, Use and Care Guides, Specifications & Features and Benefits, CAD Drawings, Overlay Panel/Frame and Toe-Kick Specifications and Instructions, Compliance Documentation and Applicable Energy Guides are available for reference and download at u-line.com.

SERVICE INFORMATION

Please consult your Use and Care Guide for troubleshooting information. Answers to Customer Frequently Asked Questions are available at u-line.com under Customer Service. You may contact U-Line directly:

GENERAL INQUIRIES:

U-Line Corporation
P.O. Box 245040
Milwaukee, Wisconsin 53224-9540 U.S.A.
Phone 1-414-354-0300
FAX 1-414-354-7905
Email: sales@u-line.com
u-line.com

SERVICE ASSISTANCE:

Phone 1-800-779-2547
FAX 1-414-354-5696
Email: onlineservice@u-line.com
u-lineservice.com

PARTS ASSISTANCE:

E-mail: onlineparts@u-line.com

BUILDING ON THREE GENERATIONS OF INNOVATION

For over five decades and through three generations, U-Line continues to be the leader in innovation, quality and performance in the premium built-in undercounter ice making, refrigeration and wine preservation market. U-Line has captivated those with an appreciation for the finer things with exceptional functionality, style, inspired innovation and attention to even the smallest details. We are known and respected for our unwavering dedication to product design, quality and selection.

In 1962, Henry Uihlein founded U-Line Corporation as an outgrowth of Ben-Hur Freezer Company and was the first to develop and patent an automatic stand-alone undercounter residential ice maker. His foresight and determination to develop new ideas and to succeed when there were no clear guidelines or solutions are evident today. The newest Uihlein generation continues to build upon the family's innovative legacy at the Milwaukee, Wisconsin based business by providing continuity and vision from which new designs and technology continue to be born.

Today the complete U-Line product collection includes Ice Makers, Ice Machines, Wine Captain[®] Models, Combo[®] Models, Refrigerator / Freezers, Refrigerators, Drawer Models and Beverage Centers. The U-Line brand offers products in the 1000 Series, 2000 Series and the Modular 3000 Series. The 1000 Series offers a more targeted priced product with appropriate features, while the 2000 Series offers upscale features, advanced technology and specialized product families. Our Modular 3000 Series provides sleek design and versatile temperature settings with our U-Select[®] control. U-Line's approach to its breadth of products, multiple price points and features allows a choice and product that will fit any lifestyle.

DESIGNED, ENGINEERED AND ASSEMBLED IN WISCONSIN, USA