

LIEBHERR

Installation Instructions

For Wine Cooler and Beverage Center

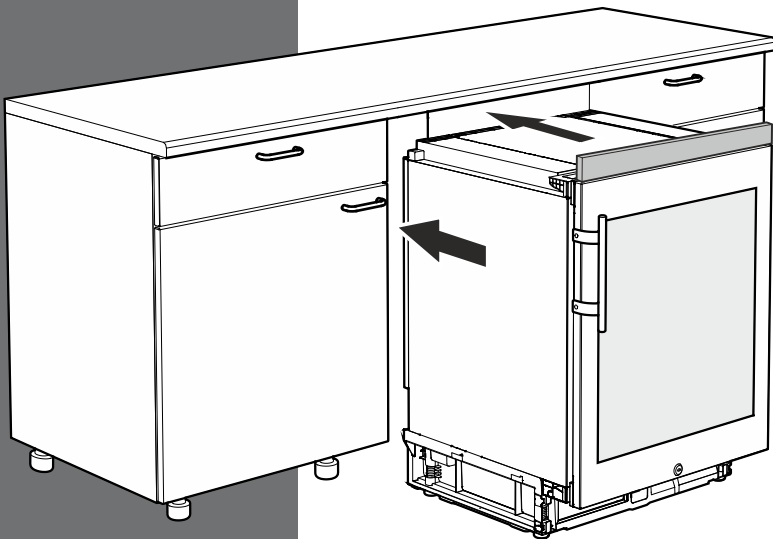

WU 3400 / WU 4500 / RU 510
7084 571-00

TABLE OF CONTENTS

Please Read and Follow these Instructions

These instructions contain Danger, Warning and Caution notes.

This information is important for safe and efficient installation and operation.

Always read and comply with all Danger, Warning and Caution notes!



DANGER!

Danger indicates a hazard which will cause serious injury or death if precautions are not followed.



WARNING!

Warning indicates a potentially hazardous situation which, if not avoided, could result in death or serious injury.



CAUTION!

Caution indicates a potentially hazardous situation which, if not avoided, may result in minor or moderate injury.

IMPORTANT

This indicates information that is especially relevant to a problem-free installation and operation.

Note to the Installer

It is very important to follow the instructions in the manual to ensure proper installation and operation of the unit.

Before installing the unit, be sure to thoroughly read and understand all of the information in this manual.

Contents	Page
Disposal of Old Appliance	3
Important Safety Information	3
Disposal of Carton	3
Electrical Safety	3
Supplied Accessories	4
Air Flow in the Appliance Base	4
Dimensions of Appliance Door.....	4
Appliance Dimensions.....	5
Installation Dimensions.....	5
Angle Bracket for Cover Panel	6
Mounting the Dust Filter	7
Appliance Venting.....	7
Installing the Appliance.....	8
Changing Over Door Hinges.....	10



R600a Refrigerant



WARNING!

The refrigerant R600a contained within the appliance is environmentally friendly, but flammable. Leaking refrigerant can ignite.

To prevent possible ignition, follow the warnings below:

- Keep ventilation openings, in the appliance enclosure or in the built-in structure, clear of obstruction. 
- Do not damage the refrigerant circuit. 
- Any repairs and work on the appliance should only be performed by the customer service department.

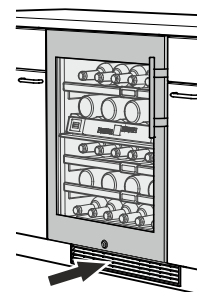

Blocking for Safety



WARNING!

To avoid a hazard due to instability of the appliance, it must be fixed in accordance with the instructions.

Disposal of Old Appliance



DANGER!

Risk of child entrapment.

Child entrapment and suffocation are not problems of the past.

Junked or abandoned refrigerators are still dangerous – even if they will sit for “just a few days.”

If you are getting rid of your old refrigerator, please follow these instructions to help prevent accidents.

Before you discard old appliances:

- Remove the doors.
- Leave the shelves in place so that children may not easily climb inside.
- Cut off the power cable from the discarded appliance. Discard separately from the appliance.
- Be sure to follow your local requirements for disposal of appliances.

Contact the trash collection agency in your area for additional information.

Important Safety Information

- To prevent injury to you or damage to the unit, the appliance should be unpacked and set up by two people.
- If the appliance is damaged on delivery, contact the supplier immediately before connecting it to the power source.
- To guarantee safe operation, ensure that the appliance is set up and connected as described in this manual.
- When disconnecting the appliance, always pull it out by the plug; never pull on the cable.
- To protect the appliance from possible damage, allow it to stand 1/2 to 1 hour in place before turning on the electricity. This allows the refrigerant and system lubrication to reach equilibrium.

Disposal of Carton

The packaging is designed to protect the appliance and individual components during transport and is made of recyclable materials.



WARNING!

Keep packaging materials away from children. Polythene sheets and bags can cause suffocation!

If possible, please recycle packaging material at a recycling facility.

Electrical Safety

Connect this appliance to a 15 amp or 20 amp, 110-120 VAC, circuit which is grounded and protected by a circuit breaker or fuse.

We recommend using a dedicated circuit for this appliance to prevent circuit overload and the chance of interruption to the appliance.

This appliance is equipped with a three-prong (grounding) polarized plug for your protection against possible shock hazards.

Where a two-prong wall receptacle is encountered, contact a qualified electrician and have it replaced with a properly grounded three-prong receptacle in accordance with all local codes and ordinances.



WARNING!

Electrocution hazard.

Electrical grounding required.

- Do not remove the round grounding prong from the plug.
- Do not use extension cords or ungrounded (two-prong) adapters.
- Do not use a power cord that is frayed or damaged.

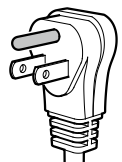

- Do not use a power strip.

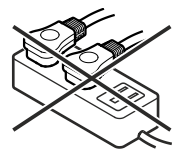

Failure to follow these instructions may result in fire, electrical shock or death.

UNPACKING

Supplied Accessories

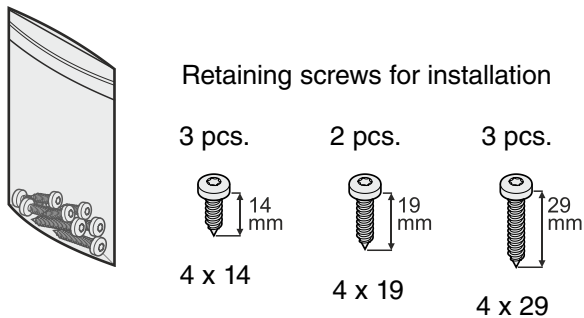
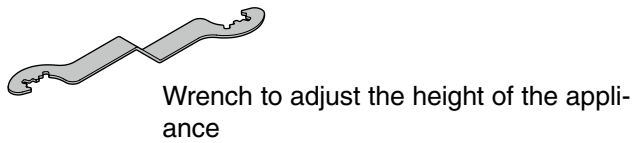
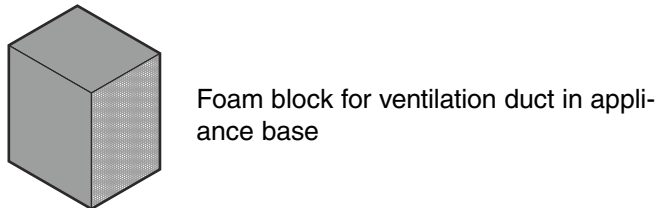
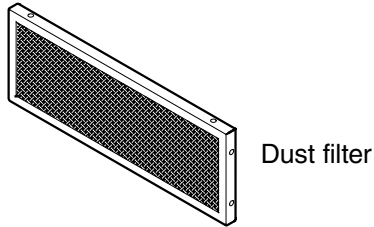
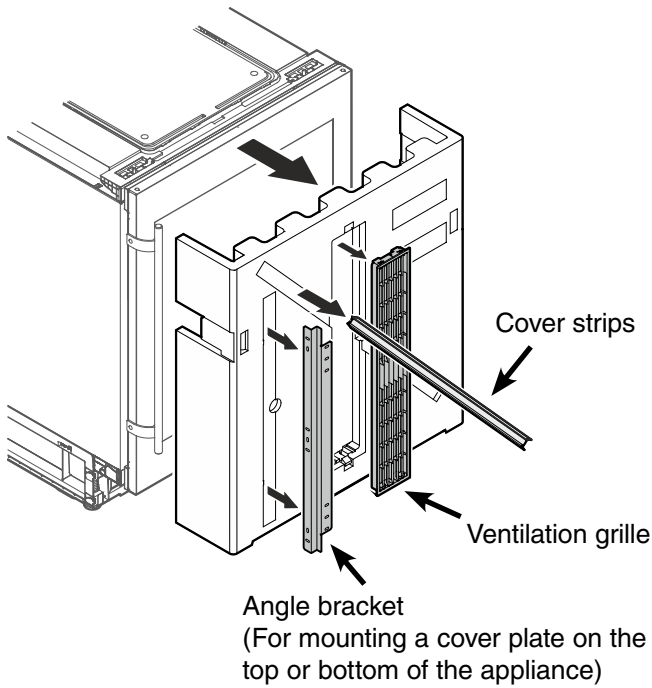

Air Flow in the Appliance Base

IMPORTANT

To ensure proper refrigeration performance of the appliance, the ventilation grille supplied must be installed.

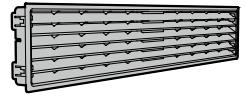

The foam block supplied must be installed in order to ensure the required air flow through the appliance base.

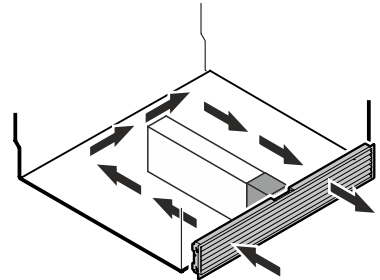

Failure to follow this instruction may result in poor refrigeration performance.

Dimensions of Appliance Door

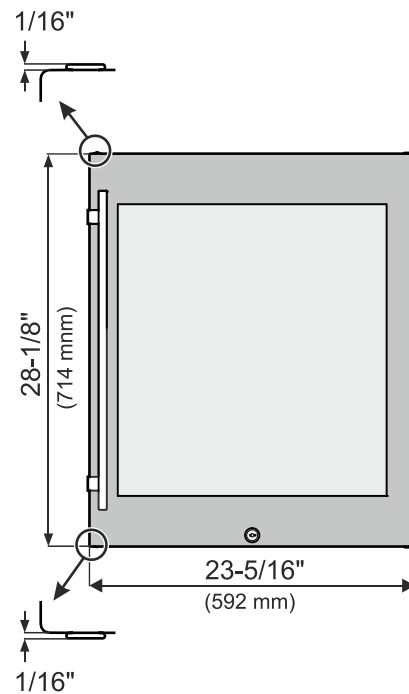

PLANNING INFORMATION

Appliance Dimensions

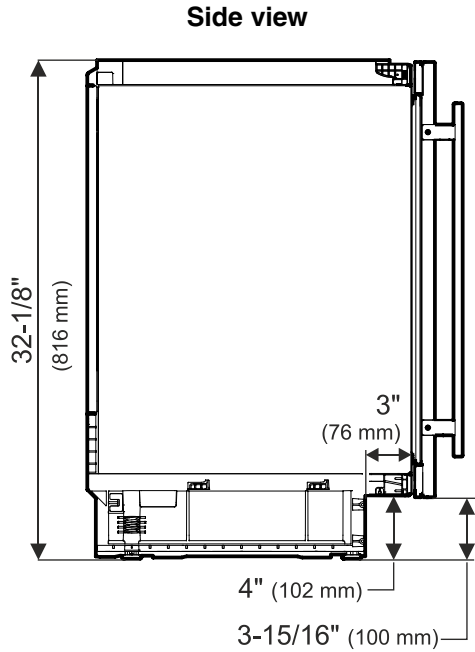

Height when adjustable feet have been screwed in as far as they will go.

Maximum height adjustment = 2" (51 mm) to allow for a 6" (153 mm) toe kick.

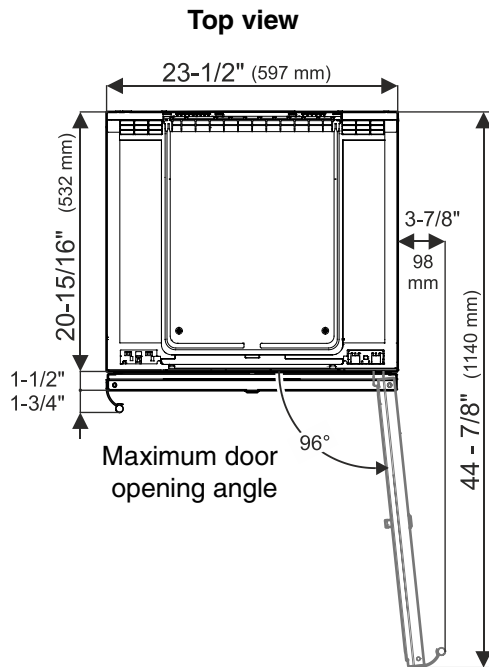

Installation Dimensions

IMPORTANT

In order to avoid any problems when installing the appliance and to avoid damage to the appliance:

The floor on which the appliance stands must be horizontal and level.

The kitchen units must be aligned horizontally and vertically.

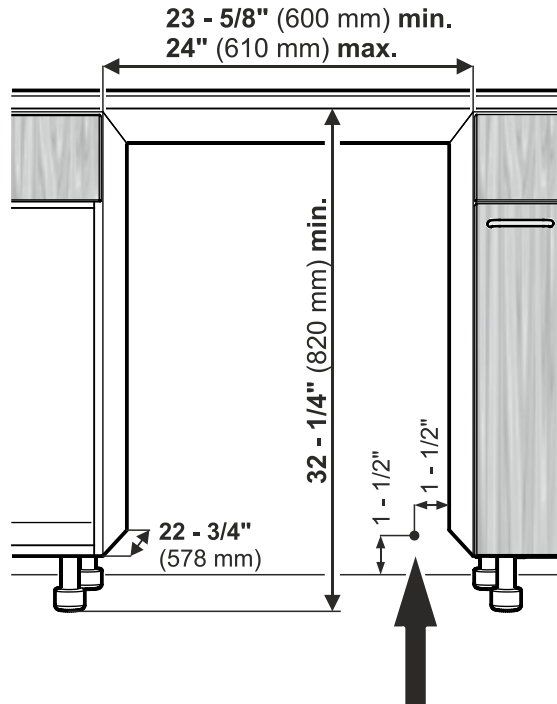

This is where the power cord extends from the back of the appliance.

Free length of the power cord = **78 - 3/4 inch (2000 mm)**

Be sure to take these specifications into consideration when choosing the location of the electrical outlet.

IMPORTANT

The electrical outlet must not be situated behind the appliance and must be easily accessible.

PLANNING INFORMATION

Angle Bracket for Cover Panel

Depending on the height of the toe kick and the height of the counter, the supplied angle bracket can be installed on the top or bottom of the appliance to cover unwanted openings with a panel.

The long holes in the bracket enable the bracket to slide in and out in order to align the filler panel with the front of the door.

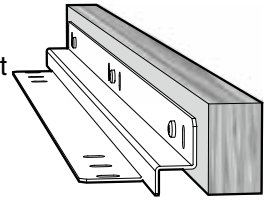

Dimensions of the mounted angle bracket

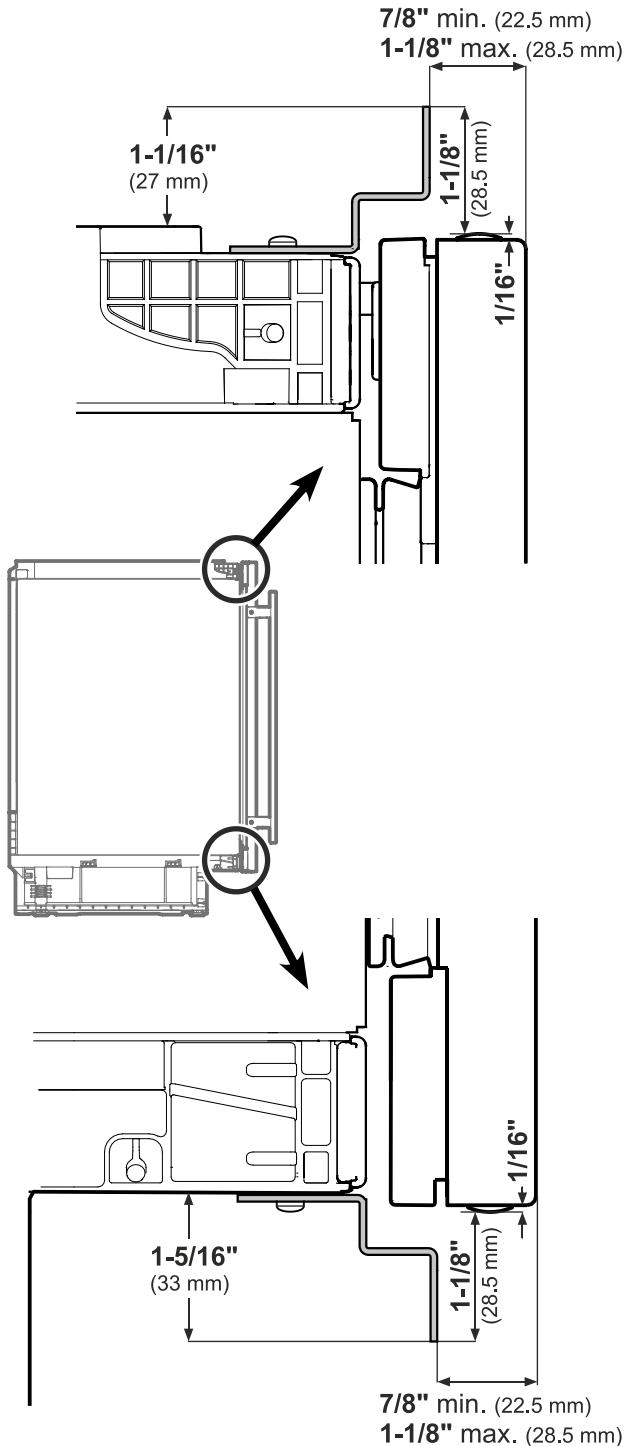

Mounting the panel onto the angle bracket

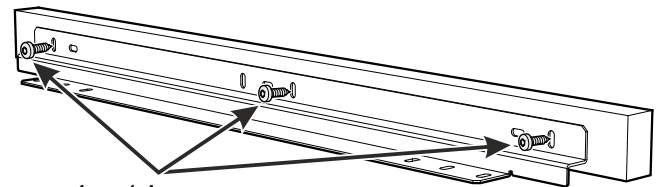

4 x 14
TX™ 15

Mount the panel onto the angle bracket using three 4 x 14 screws.

Mounting the premounted bracket on the appliance top

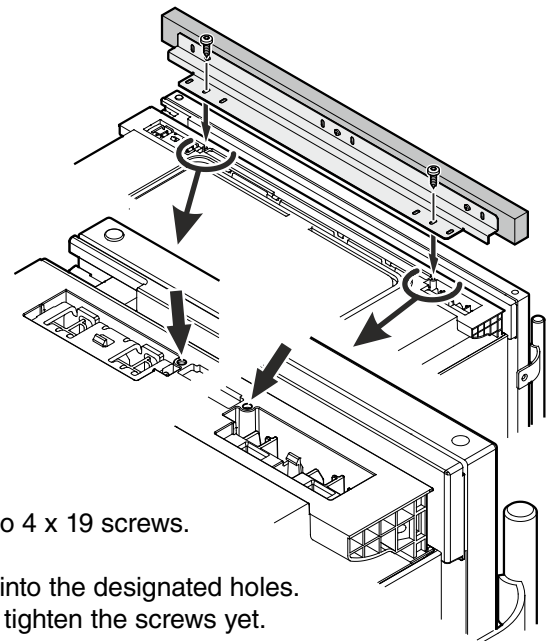

- Use two 4 x 19 screws.
- Screw into the designated holes. Do not tighten the screws yet.
- Adjust the bracket until the front surface of the panel is flush with the door front.
- Finally, tighten the screws.

Mounting the premounted bracket on the appliance bottom

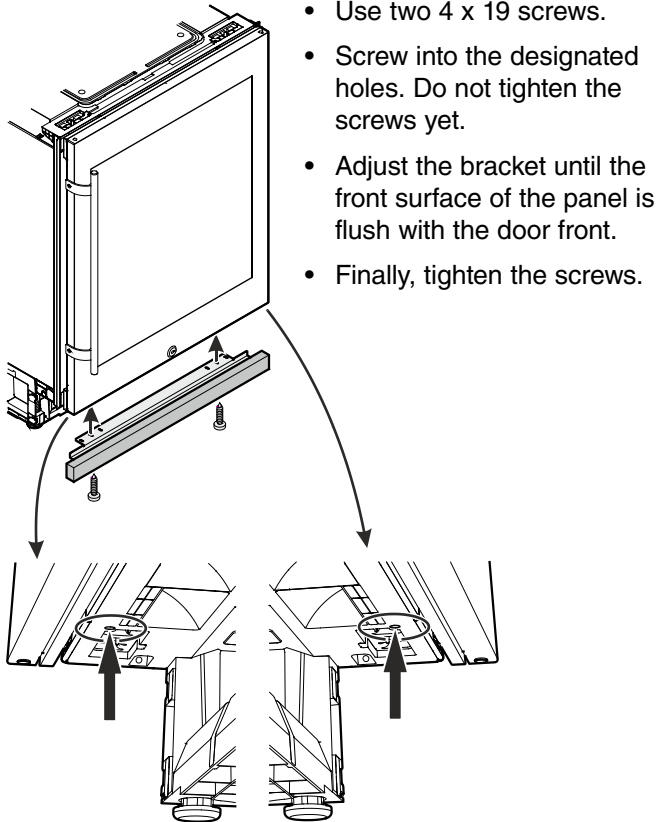

Mounting the Dust Filter

The supplied dust filter prevents dirt from getting into the motor compartment, which can impair the refrigeration performance.

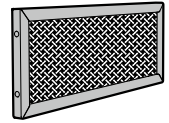

Therefore, always install the dust filter.

Remove the protective film from the dust filter.

Insert the filter at the bottom and click into place at the top.

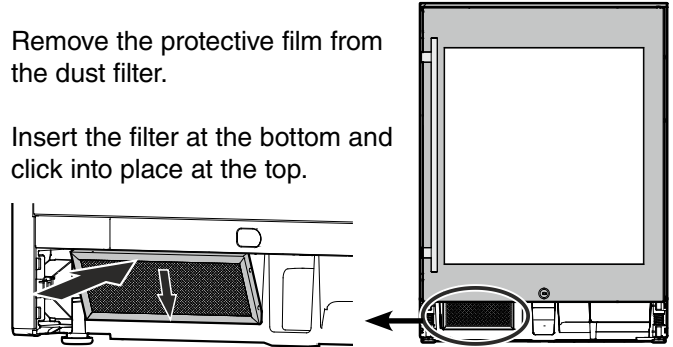

Appliance Venting

The required air flow is directed through the toe kick base.

It is important to use the provided ventilation grille for the ventilation opening.

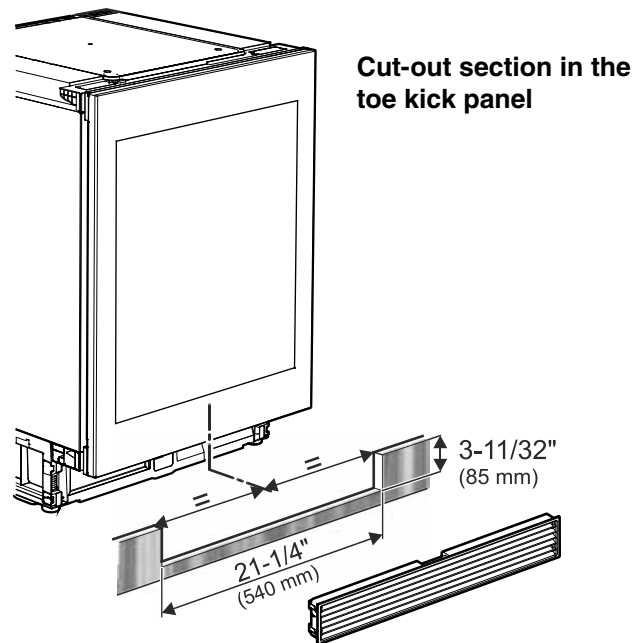
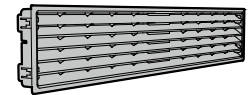

IMPORTANT

The cut-out section in the toe kick panel must be centered in relation to the appliance and in the uppermost part of the toe kick.

INSTALLATION

Installing the Appliance

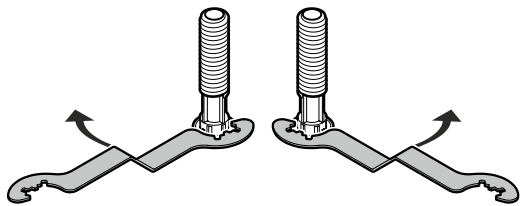
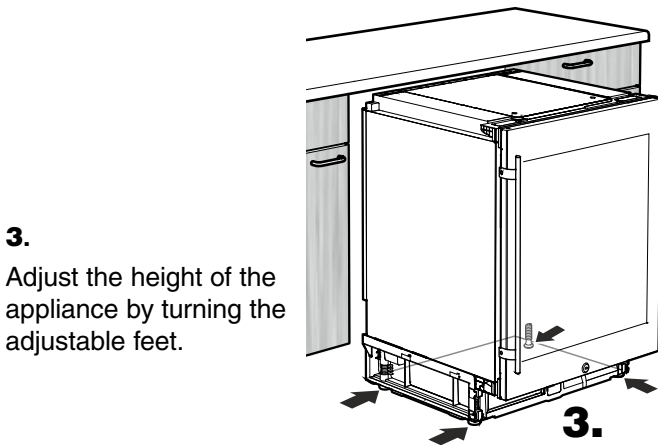
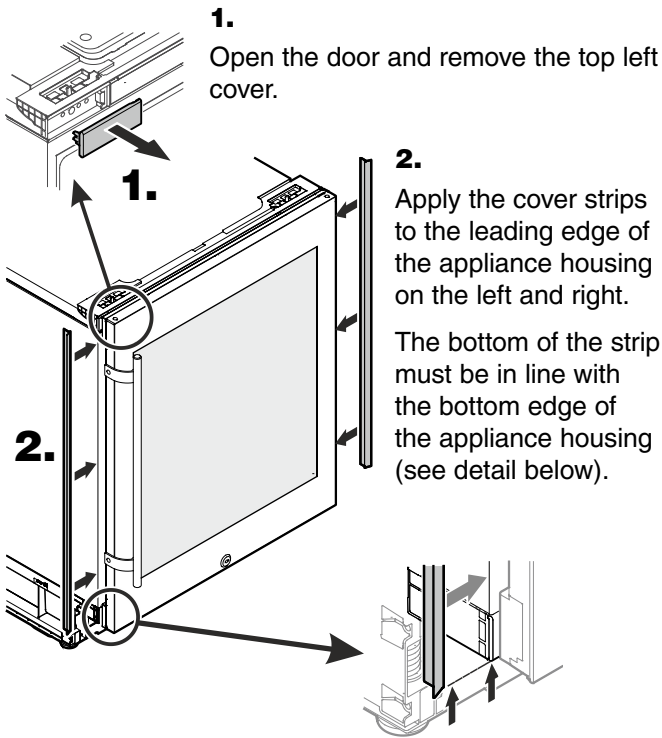

Turn the wrench counterclockwise to raise the appliance and clockwise to lower it. Position the wrench accordingly.

IMPORTANT

The appliance must be aligned horizontally and vertically. If the appliance is not level, the main body of the appliance can become deformed and the door will not close properly.

Installing version without cover panel on the appliance top

Adjust the height of the appliance leaving a gap of approx. 1/8" between the appliance top and the underside of the countertop.

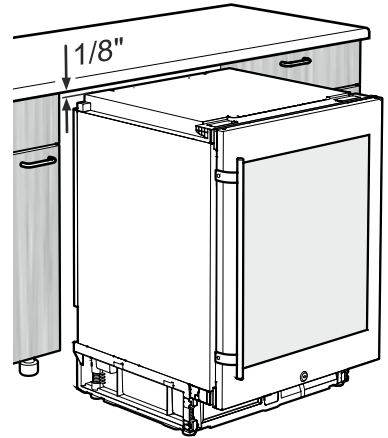

Installing version with mounted cover panel on the appliance top

Adjust the height of the appliance leaving a gap of approx. 1/8" between the top of the cover panel and the underside of the countertop.

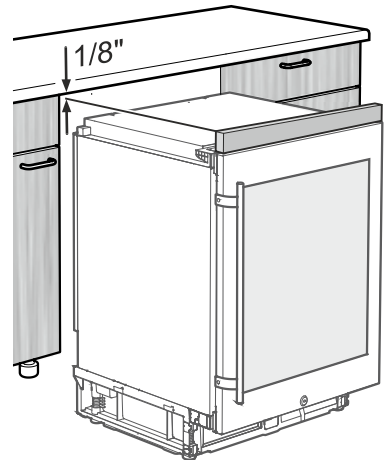

4. Slide in the appliance until the front surface of the appliance door is flush with the unit fronts.

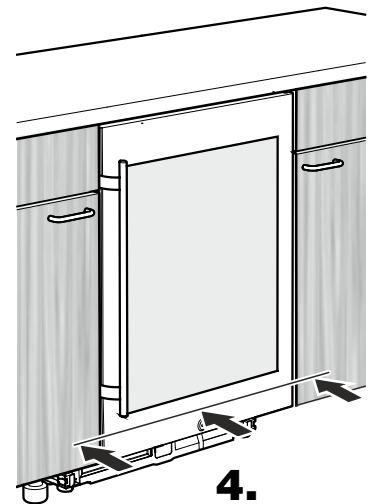

WARNING!

When sliding in the appliance, make sure not to damage the power cord!

5.

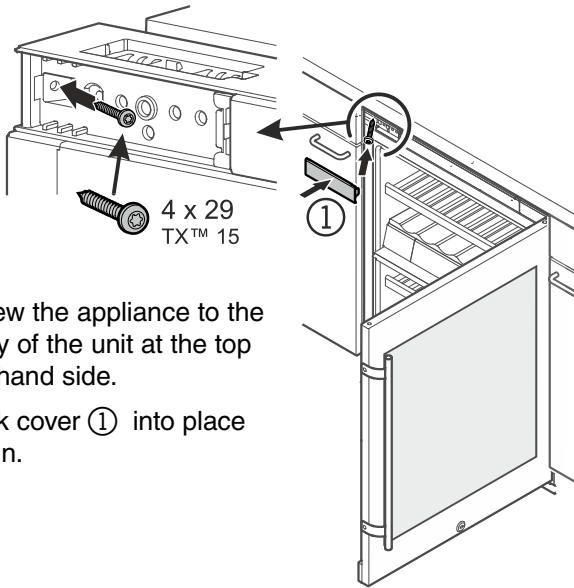

5.

- Screw the appliance to the body of the unit at the top left-hand side.
- Click cover ① into place again.

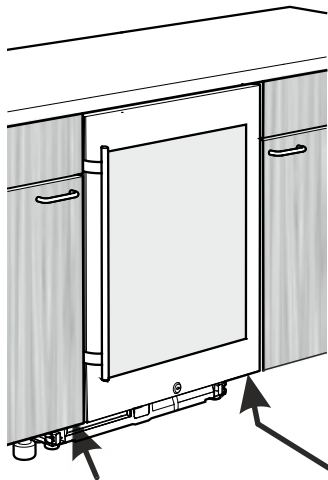

- 6.** Screw the appliance to the body of the unit at the bottom on the left and right.

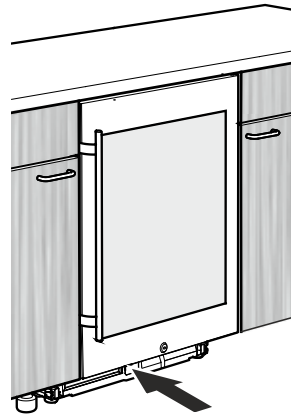
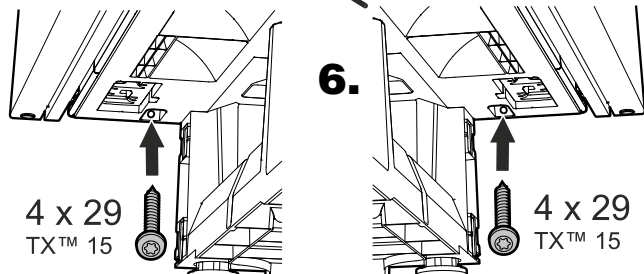

- 7.** Insert the foam block approx. 1/2" into the opening in the appliance base as indicated.

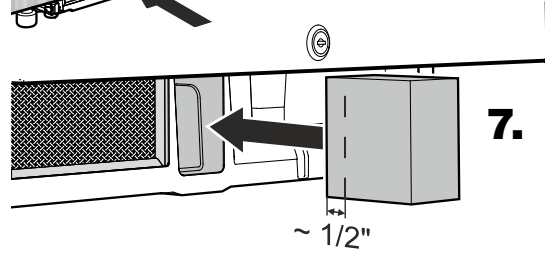

IMPORTANT

If the foam block is not installed, the appliance will not deliver optimal refrigeration performance during operation.

- 8.** Insert the ventilation grille into the toe kick panel.

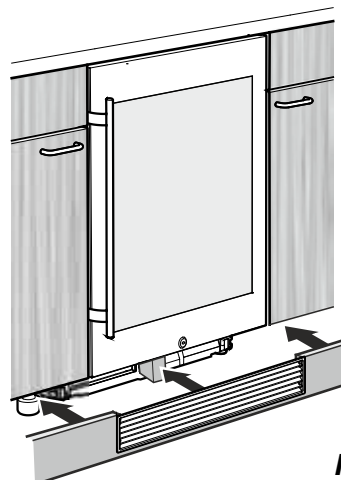
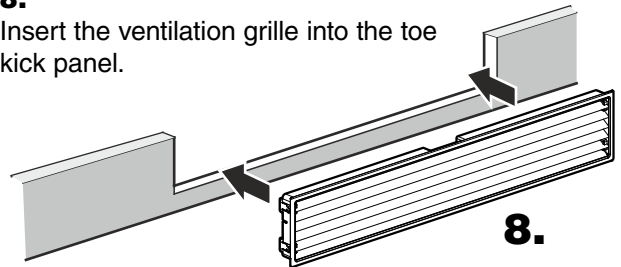

- 9.** Fit the toe kick panel. As you do this, the foam block is pushed backwards into its final position.

9.

Important

The foam block must be touching the ventilation grille.

CHANGING OVER DOOR HINGES

Changing Over Door Hinges

Door hinges should only be changed by a trained expert.

Changing over the door hinges requires two people.

Note

The following description depicts appliance WU 3400.

The same procedure applies to changing the door hinges on the WU 4500 and RU 510 appliances.

1. Remove screw.

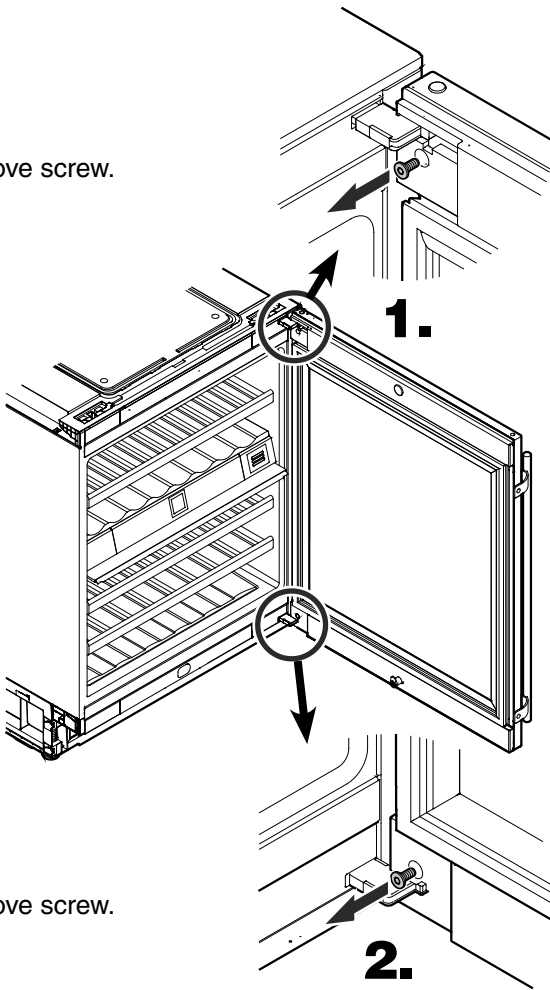

2. Remove screw.

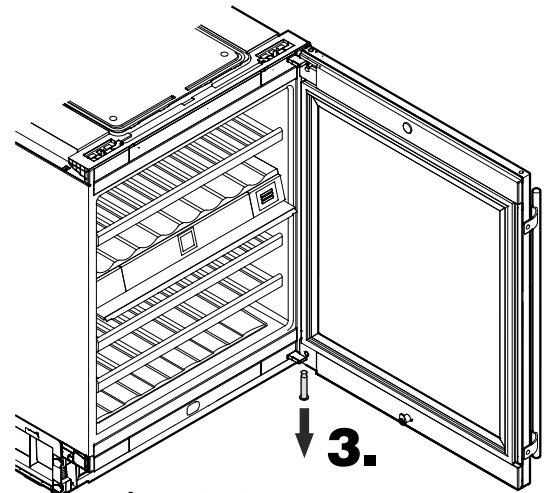

Important

The door must now be held secure by another person.

3. Pull out hinge pin.

4. Remove upper hinge pin.

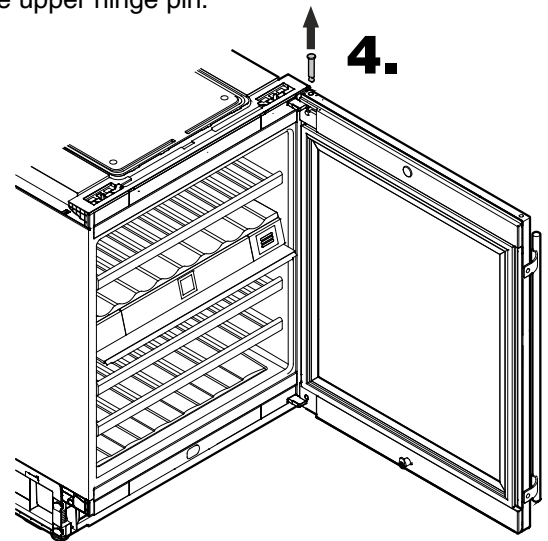

CHANGING OVER DOOR HINGES

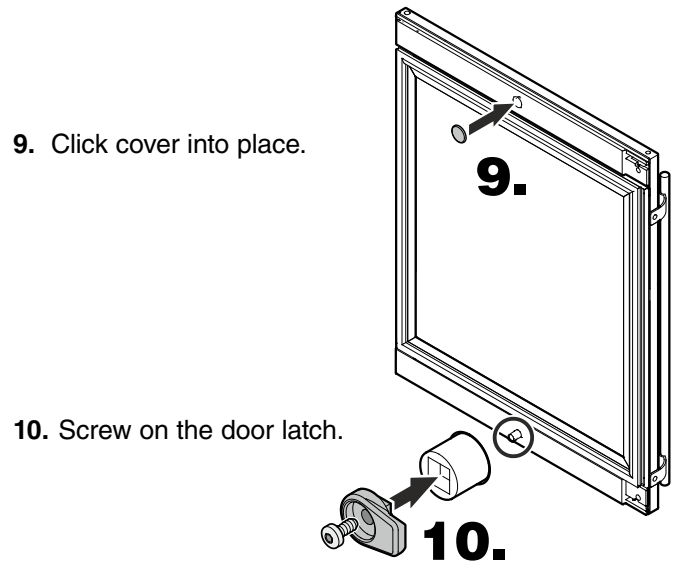
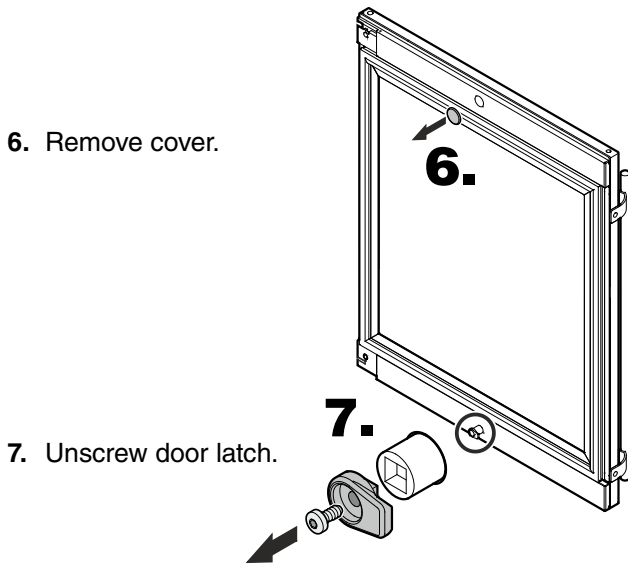
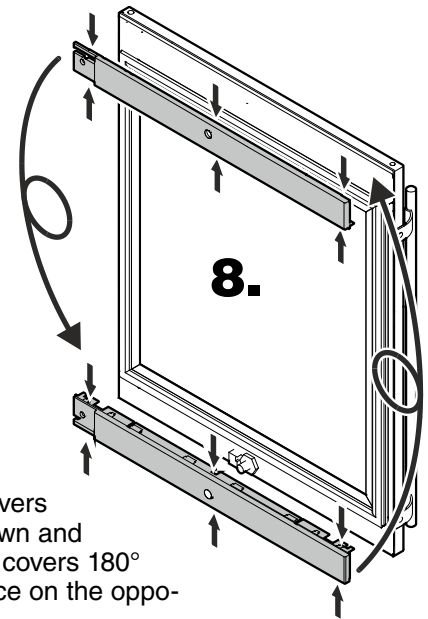
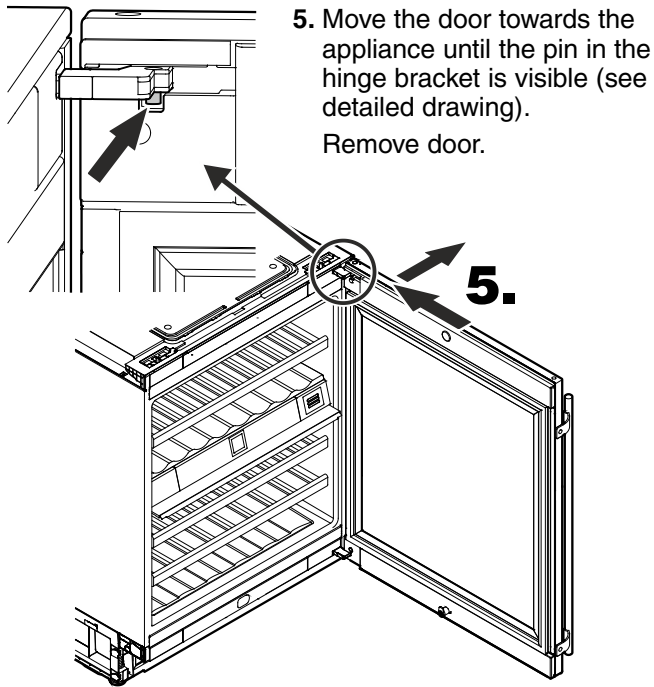

CHANGING OVER DOOR HINGES

11. Transfer door handle and plugs to the opposite side.

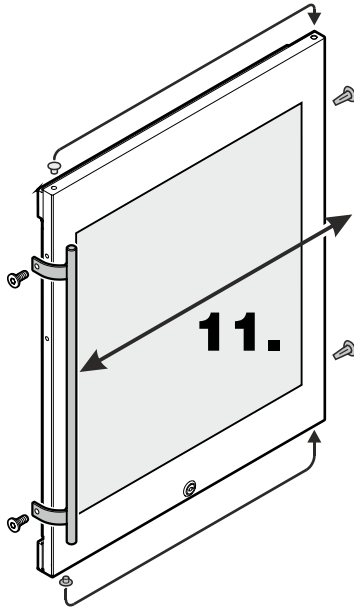

13.

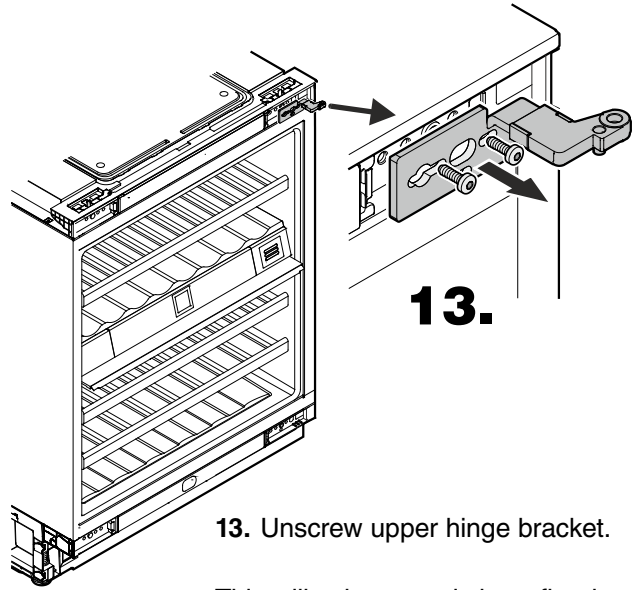

13. Unscrew upper hinge bracket.

This will subsequently be refitted on the left at the bottom.

12. Remove the covers.

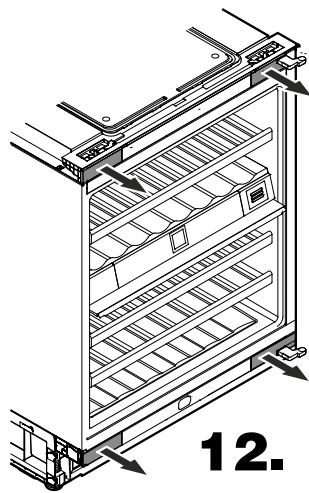

12.

14. Unscrew the lower hinge bracket.

This will subsequently be refitted on the left at the top.

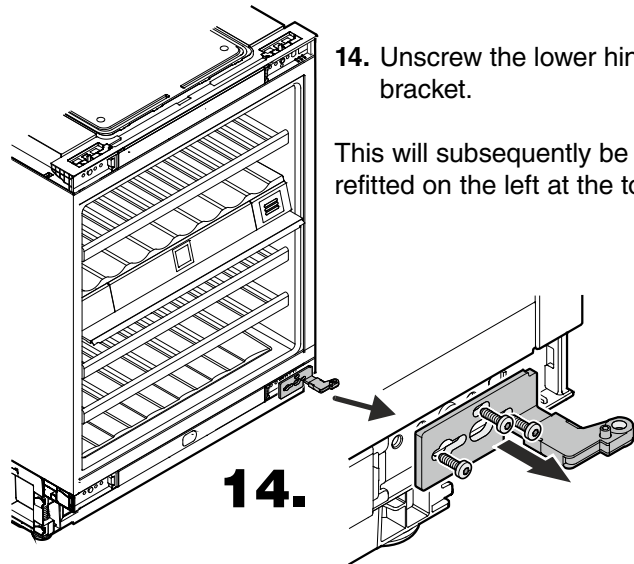

14.

CHANGING OVER DOOR HINGES

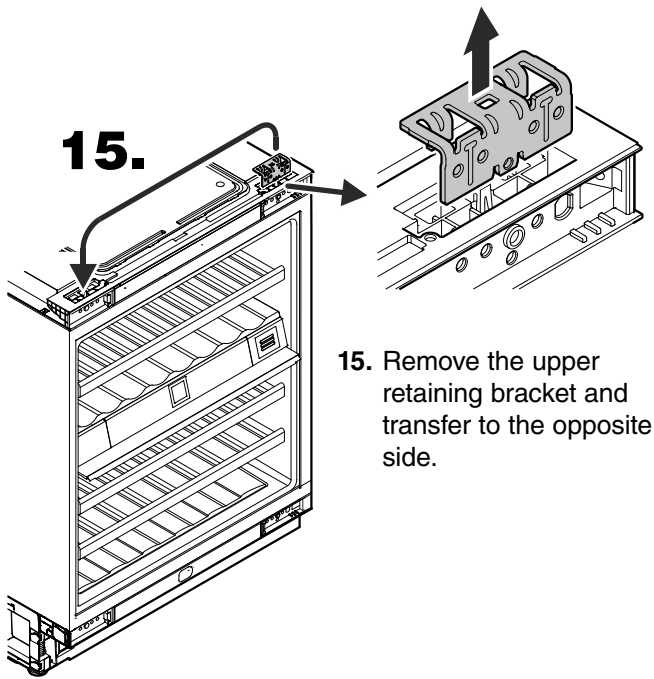

15. Remove the upper retaining bracket and transfer to the opposite side.

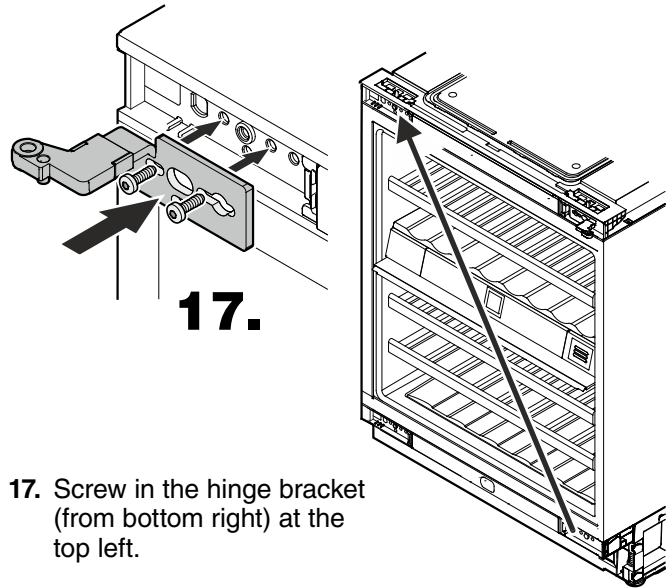

17. Screw in the hinge bracket (from bottom right) at the top left.

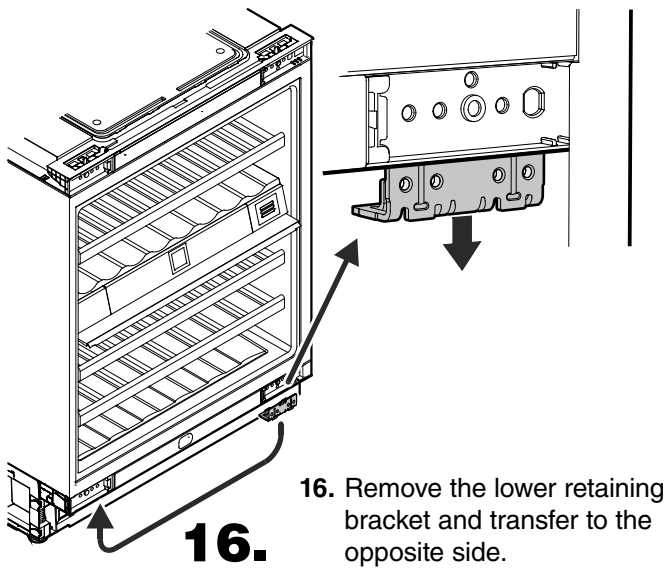

16. Remove the lower retaining bracket and transfer to the opposite side.

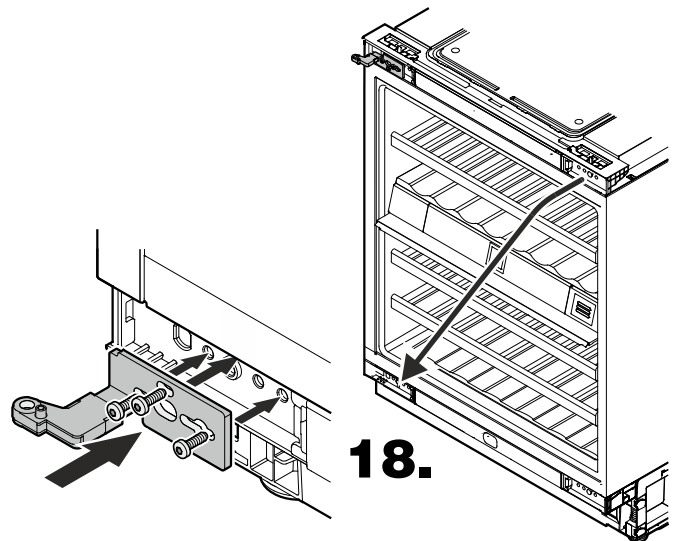

18. Screw in the hinge bracket (from top right) at the bottom left.

CHANGING OVER DOOR HINGES

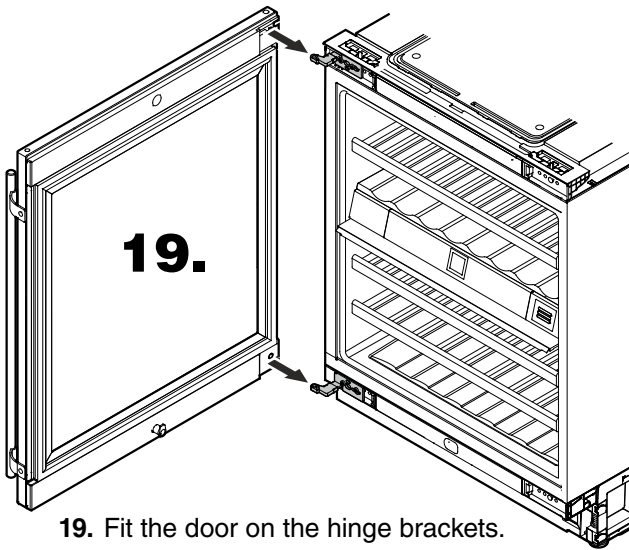

19. Fit the door on the hinge brackets.

Important

The door must now be held secure by another person.

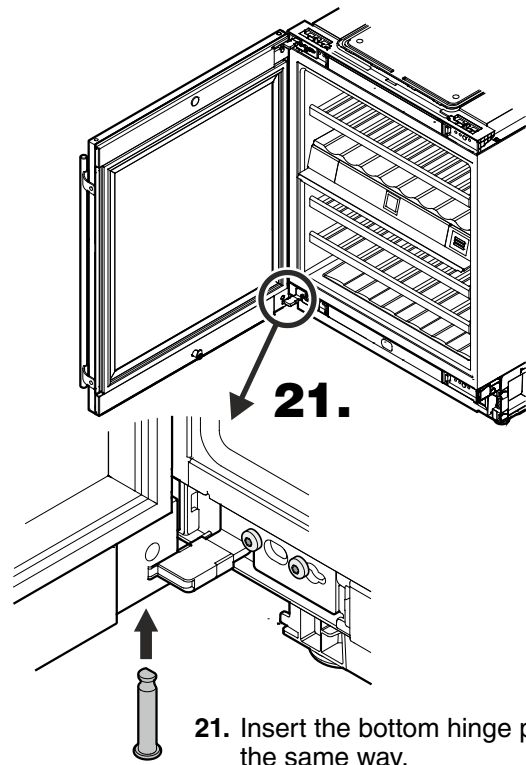

21. Insert the bottom hinge pin in the same way.

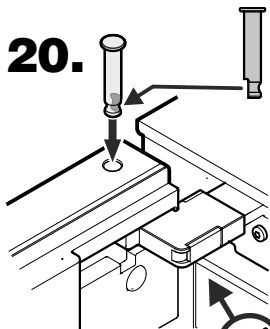

20. Insert hinge pin.

The door must be open 90°. Insert the hinge pin with the flat part facing the appliance. The hinge pin must be fully inserted in the borehole and may not protrude at the top.

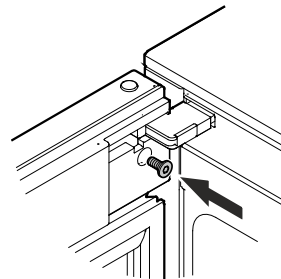

22. Screw in the screws at the top and bottom.

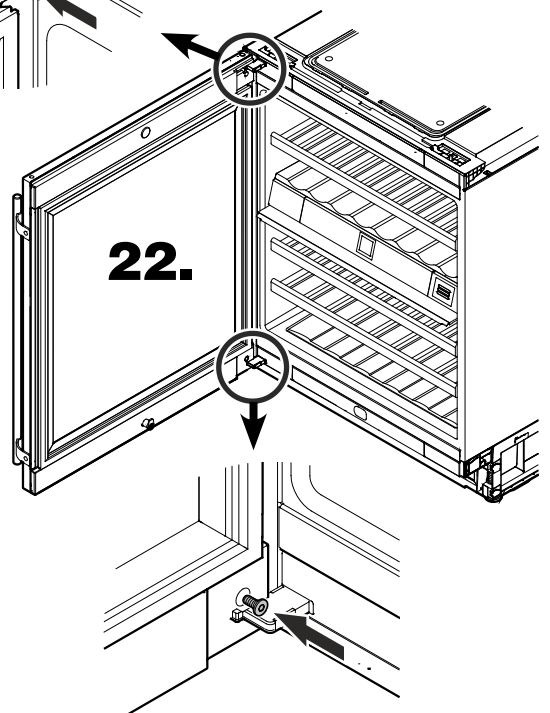
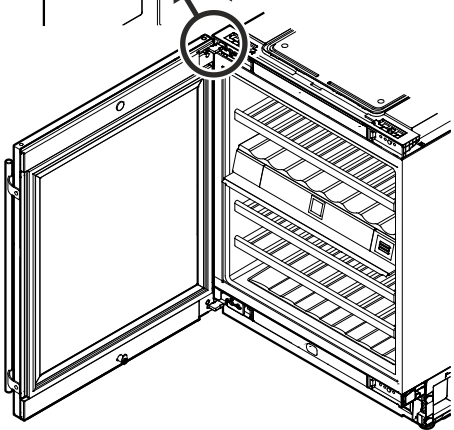

CHANGING OVER DOOR HINGES

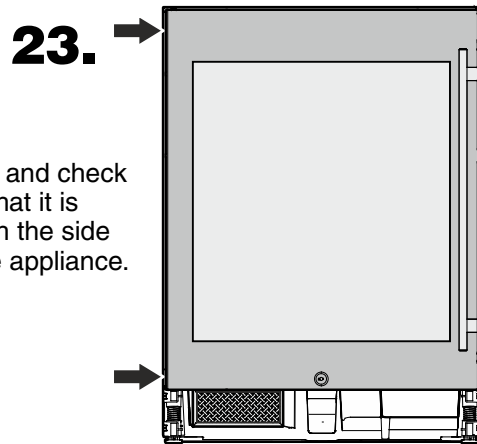

23. Close door and check to ensure that it is aligned with the side walls of the appliance.

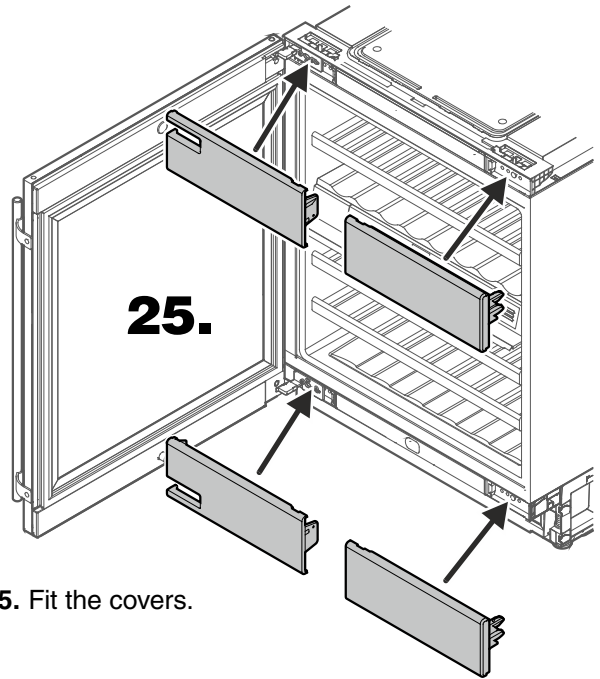

25. Fit the covers.

Adjusting the lateral tilt of the door

If the door is at an angle, adjust the angle.

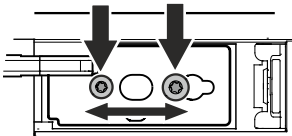

24. Undo screws and slide hinge bracket to the right or left. Tighten screws.

